



**RF DIRECTIONAL
THRULINE[®] WATTMETER**

MODEL 4314C

©COPYRIGHT 2012 BY BIRD TECHNOLOGIES GROUP
INSTRUCTION BOOK PART NUMBER 920-4314C REV. A

THRULINE IS A REGISTERED TRADEMARK OF
BIRD TECHNOLOGIES GROUP

Safety Precautions

The following are general safety precautions that are not necessarily related to any specific part or procedure, and do not necessarily appear elsewhere in this publication. These precautions must be thoroughly understood and apply to all phases of operation and maintenance.

WARNING

Keep Away From Live Circuits

Operating Personnel must at all times observe general safety precautions. Do not replace components or make adjustments to the inside of the test equipment with the high voltage supply turned on. To avoid casualties, always remove power.

WARNING

Shock Hazard

Do not attempt to remove the RF transmission line while RF power is present.

WARNING

Do Not Service Or Adjust Alone

Under no circumstances should any person reach into an enclosure for the purpose of service or adjustment of equipment except in the presence of someone who is capable of rendering aid.

WARNING

Safety Earth Ground

An uninterruptible earth safety ground must be supplied from the main power source to test instruments. Grounding one conductor of a two conductor power cable is not sufficient protection. Serious injury or death can occur if this grounding is not properly supplied.

WARNING

Resuscitation

Personnel working with or near high voltages should be familiar with modern methods of resuscitation.

WARNING

Remove Power

Observe general safety precautions. Do not open the instrument with the power on.

Safety Symbols

WARNING

Warning notes call attention to a procedure, which if not correctly performed, could result in personal injury.

CAUTION

Caution notes call attention to a procedure, which if not correctly performed, could result in damage to the instrument.

Note: *Calls attention to supplemental information.*

Warning Statements

The following safety warnings appear in the text where there is danger to operating and maintenance personnel, and are repeated here for emphasis.

WARNING

Exposure to RF power radiation and the possibility of RF shock or burns exist with some operating conditions. Always be sure to turn off the transmitter when connecting or disconnecting a wattmeter.

Be sure the transmission line is terminated into a load or antenna.

When a Plug-In Element is removed from the RF line socket, the line section center conductor is exposed. Do not put fingers or other objects into the Plug-In Element socket while RF power is applied.

On pages 3 and 9.

WARNING

Always be sure transmitter power is off before disconnecting the unit from the transmission line.

On page 19.

Caution Statements

The following equipment cautions appear in the text and are repeated here for emphasis.

CAUTION

Do not drop the Thruline Wattmeter or its elements or subject them to hard blows. The meter is shock mounted in the wattmeter housing, but its delicate mechanism may be damaged by severe impact.

On page 3.

CAUTION

Severe damage to the Plug-In Element or wattmeter can result from exposure to excessive RF power. Make sure the Plug-In Element installed in the wattmeter has a sufficiently high wattage rating to handle the line load when it is first applied to the RF line.

On page 4.

CAUTION

Use reasonable care in handling. Do not drop or subject the wattmeter or elements to hard blows as accuracy may be impaired or other damage may result.

On pages 9 and 21.

CAUTION

Do not apply RF power to the wattmeter in excess of the full scale range of the element.

On page 9.

CAUTION

When making low reflection readings using a more sensitive element, take care to insert the element so that it senses reflected power only. Do not rotate the element in the socket so that it is subjected to forward power. This can result in damage to the Plug-In Element, the wattmeter, or both.

On page 14.

CAUTION

This instrument contains static sensitive electronic components. Before opening or servicing the unit, make sure that you understand and practice electrostatic discharge component handling. Failure to comply may result in permanent damage to sensitive components.

On page 26.

CAUTION

If other than Female N type connectors are used, limit power and frequency to the capabilities of the RF coaxial cable or connectors used. Damage to connectors or errors in reading could result.

On page 26.

Safety Statements

USAGE

ANY USE OF THIS INSTRUMENT IN A MANNER NOT SPECIFIED BY THE MANUFACTURER MAY IMPAIR THE INSTRUMENT'S SAFETY PROTECTION.

USO

EL USO DE ESTE INSTRUMENTO DE MANERA NO ESPECIFICADA POR EL FABRICANTE, PUEDE ANULAR LA PROTECCIÓN DE SEGURIDAD DEL INSTRUMENTO.

BENUTZUNG

WIRD DAS GERÄT AUF ANDERE WEISE VERWENDET ALS VOM HERSTELLER BESCHRIEBEN, KANN DIE GERÄTESICHERHEIT BEEINTRÄCHTIGT WERDEN.

UTILISATION

TOUTE UTILISATION DE CET INSTRUMENT QUI N'EST PAS EXPLICITEMENT PRÉVUE PAR LE FABRICANT PEUT ENDOMMAGER LE DISPOSITIF DE PROTECTION DE L'INSTRUMENT.

IMPIEGO

QUALORA QUESTO STRUMENTO VENISSE UTILIZZATO IN MODO DIVERSO DA COME SPECIFICATO DAL PRODUTTORE LA PROZIONE DI SICUREZZA POTREBBE VENIRNE COMPROMESSA.

SERVICE

SERVICING INSTRUCTIONS ARE FOR USE BY SERVICE - TRAINED PERSONNEL ONLY. TO AVOID DANGEROUS ELECTRIC SHOCK, DO NOT PERFORM ANY SERVICING UNLESS QUALIFIED TO DO SO.

SERVICIO

LAS INSTRUCCIONES DE SERVICIO SON PARA USO EXCLUSIVO DEL PERSONAL DE SERVICIO CAPACITADO. PARA EVITAR EL PELIGRO DE DESCARGAS ELÉCTRICAS, NO REALICE NINGÚN SERVICIO A MENOS QUE ESTÉ CAPACITADO PARA HACERLO.

WARTUNG

ANWEISUNGEN FÜR DIE WARTUNG DES GERÄTES GELTEN NUR FÜR GESCHULTES FACHPERSONAL.

ZUR VERMEIDUNG GEFAHRLICHE, ELEKTRISCHE SCHOCKS, SIND WARTUNGSARBEITEN AUSSCHLIEßLICH VON QUALIFIZIERTEM SERVICEPERSONAL DURCHZUFÜHREN.

ENTRETIEN

L'EMPLOI DES INSTRUCTIONS D'ENTRETIEN DOIT ÊTRE RÉSERVÉ AU PERSONNEL FORMÉ AUX OPÉRATIONS D'ENTRETIEN. POUR PRÉVENIR UN CHOC ÉLECTRIQUE DANGEREUX, NE PAS EFFECTUER D'ENTRETIEN SI L'ON N'A PAS ÉTÉ QUALIFIÉ POUR CE FAIRE.

ASSISTENZA TECNICA

LE ISTRUZIONI RELATIVE ALL'ASSISTENZA SONO PREVISTE ESCLUSIVAMENTE PER IL PERSONALE OPPORTUNAMENTE ADDESTRATO. PER EVITARE PERICOLOSE SCOSSE ELETTRICHE NON EFFETTUARE ALCUNA RIPARAZIONE A MENO CHE QUALIFICATI A FARLA.

RF VOLTAGE MAY BE PRESENT IN RF ELEMENT SOCKET - KEEP ELEMENT IN SOCKET DURING OPERATION.

DE LA TENSION H.F. PEAT ÊTRE PRÉSENTE DANS LA PRISE DE L'ÉLÉMENT H.F. - CONSERVER L'ÉLÉMENT DANS LA PRISE LORS DE L'EMPLOI.

HF-SPANNUNG KANN IN DER HF-ELEMENT-BUCHSE ANSTEHEN - ELEMENT WÄHREND DES BETRIEBS EINGESTÖPSELT LASSEN.

PUEDA HABER VOLTAJE RF EN EL ENCHUFE DEL ELEMENTO RF - MANTENGA EL ELEMENTO EN EL ENCHUFE DURANTE LA OPERACION.

IL PORTAELEMENTO RF PUÒ PRESENTARE VOLTAGGIO RF - TENERE L'ELEMENTO NELLA PRESA DURANTE IL FUNZIONAMENTO.

About This Manual

This manual covers the operating and maintenance instructions for the following models:

4314C

Changes to this Manual

We have made every effort to ensure this manual is accurate. If you discover any errors, or if you have suggestions for improving this manual, please send your comments to our Solon, Ohio factory. This manual may be periodically updated. When inquiring about updates to this manual refer to the part number and revision on the title page.

Literature Contents

Chapter Layout

Introduction - Describes the features of the Thruline wattmeter, lists equipment supplied and optional equipment.

Installation - Describes how to set up the Thruline wattmeter.

Operating Instructions - Describes procedures required for operating the wattmeter.

Maintenance - Lists routine maintenance tasks as well as troubleshooting for common problems. Specifications and parts information are also included.

TABLE OF CONTENTS

Safety Precautions	iii
Safety Symbols	iv
Warning Statements	iv
Caution Statements	iv
Safety Statements	vi
About This Manual	ix
Changes to this Manual	ix
Literature Contents	ix
Chapter Layout	ix
Chapter 1 4341C Introduction	1
Purpose and Function	1
Description	1
Performance Characteristics and Capabilities	1
Power Requirements	2
Additional Equipment	2
Chapter 2 Installation	3
Portability	3
Connections	3
Chapter 3 Theory of Operation	5
Traveling Wave Viewpoint	5
Coupling Circuit	5
Peak Power Operation	6
Component Description	7
Chapter 4 Operating Instructions	9
Zero Adjust Meter	9
Plug-In Element Selection and Insertion	10
Measurements	10
CW Power Measurements	10
Peak Power Measurements	10
Load Power	11
Determining VSWR	11
Making Low Reflection Readings	14
Testing Lines, Connectors, Filters & Related Components	14
Determining Attenuation with a Single Wattmeter	15
Open Circuit Method	15
Short Circuit Method	15

Measuring Percentage Of Positive Modulation	16
Performance Notes	18
Shutdown	19
Chapter 5 Maintenance	21
Cleaning	21
Preventative Maintenance	21
Line Section Care	21
Inspection	22
Troubleshooting	22
Battery Procedures	24
Testing the Batteries	24
Replacing the Batteries	24
Replacing the Meter	25
Replacing the Instrumentation Module	26
Replacing the Quick-Change Connectors	27
Calibrating the Wattmeter	28
PEAK Mode Zero Adjust	28
PEAK Mode Gain Adjust	28
Customer Service	30
Specifications	31
Replacement Parts	32
*Available QC Type Connectors	32
Limited Warranty	35

Purpose and Function

The Model 4314C Thruline Wattmeter is an insertion-type RF wattmeter designed to measure power flow and load match in 50 ohm coaxial transmission lines. It is intended for use on CW, AM, FM, SSB, TV, and pulse signals only.

Description

The Model 4314C Thruline Wattmeter is a portable unit contained in a die cast aluminum housing. The unit is equipped with a plastic strap for carrying, four rubber shock feet on the base, and four rubber bumpers on the back which allow the unit to stand vertical or lie flat in a horizontal position when used. For additional protection, the meter is specially shock mounted. A slotted screw is provided on the lower front face of the meter for zeroing the pointer.

The RF line section face below the meter protrudes slightly from the wattmeter housing with the Plug-In Element socket in the center. The circuit module is mounted on the line section inside the housing. It has an attached phosphor bronze spring contact finger, which protrudes through a lateral hole and into the Plug-In Element socket on the RF line section. The finger has a button on its end which makes connection with the contacts of the Plug-in Element. The silver-plated brass RF line section is precision-made to provide the best possible impedance match to the coaxial RF transmission line in which the wattmeter is inserted. At each end of the line section are Bird Quick-Change type RF connectors, which may be quickly interchanged with any other Bird "QC" connectors.

Performance Characteristics and Capabilities

To make measurements, insert a Plug-In Element into the line section socket and rotate it to either stop. Point the element arrow in the source to load direction of power flow and the meter will display a reading of forward power. Rotate the element so that the arrow is pointed in the opposite direction to obtain a reflected power reading. With known values of forward and reflected power the load match can now be determined by calculating the VSWR or by using the graphs supplied in this manual (Figure 4 on page 12 and Figure 5 on page 13).

Setting the front panel toggle switch to PEAK mode gives the wattmeter the capability of indicating peak pulse or envelope power.

Power Requirements

The Model 4314C can operate from two different power sources. The wattmeter comes supplied with two 9 V alkaline batteries which typically provide 20 hours of operation. An AC adapter is also available rated at 100-240 +/- 10% VAC @ 50/60Hz.

Additional Equipment

The only additional equipment required by the Model 4314C is a Plug-In Element. Refer to www.bird-technologies.com for a list of current elements available.

Portability

The Model 4314C is a portable instrument; the housing is not designed for fixed mounting. A strap is provided for carrying purposes.

CAUTION

Do not drop the Thruline Wattmeter or its elements or subject them to hard blows. The meter is shock mounted in the wattmeter housing, but its delicate mechanism may be damaged by severe impact.

When transporting the Thruline Wattmeter, it is best to insert the original dust plug, or a Plug-In Element with the arrow pointed down, in the measuring socket, and secure it with the catch. This will shunt the meter and serve to protect it by dampening the pointer action during handling or shipping. Also, set the wattmeter control to CW mode. In this position, any unnecessary battery drain will be avoided. Handle the Plug-In Elements with care at all times as their calibration could be disturbed if they are dropped.

WARNING

Exposure to RF power radiation and the possibility of RF shock or burns exist with some operating conditions. Always be sure to turn off the transmitter when connecting or disconnecting a wattmeter.

Be sure the transmission line is terminated into a load or antenna. When a Plug-In Element is removed from the RF line socket, the line section center conductor is exposed. Do not put fingers or other objects into the Plug-In Element socket while RF power is applied.

Connections

The Model 4314C Wattmeter is normally supplied with two Female N type connectors which are of the Bird Quick-Change "QC" design. Other "QC" connectors are available as listed in the Replacement Parts. See "Replacement Parts" on page 32.

1. Insert the Model 4314C Thruline Wattmeter in coaxial transmission lines of 50 ohms nominal impedance.

Note: *The signal source and load connections can be made to either side of the wattmeter with no difference in effect. Use a coaxial transmission line fitted with suitable matching RF connectors. If cables of other than 50 ohms impedance are used, a mismatch will occur which could cause serious inaccuracies in the readings.*

CAUTION

Severe damage to the Plug-In Element or wattmeter can result from exposure to excessive RF power. Make sure the Plug-In Element installed in the wattmeter has a sufficiently high wattage rating to handle the line load when it is first applied to the RF line.

Figure 1 Model 4314C Outline Drawing

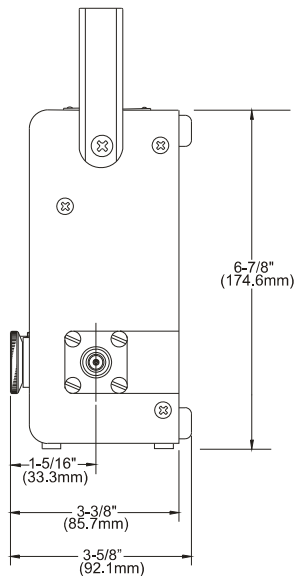
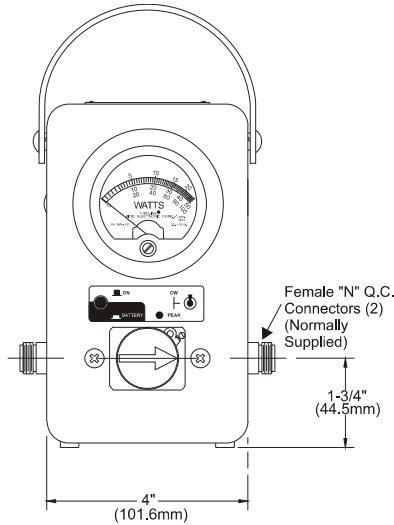

Traveling Wave Viewpoint

The operation of this wattmeter is based on the travelling wave concept of RF transmission. As RF power is applied to a transmission line, there is a forward wave travelling from the transmitter to the load, and a reflected wave travelling from the load to the transmitter. The closer the load is matched to the transmission line, the smaller the reflected wave will be. To determine the amount of power dissipated in a load resistor, it is necessary to determine the wattage of the forward wave and the wattage of the reflected wave. The difference between the two indicates load power.

VSWR (Voltage Standing Wave Ratio) has become a widely used tool in the travelling wave concept. The standing waves which are produced by transmission line mismatch cannot be read directly. However, the VSWR can be easily determined by the use of the VSWR Conversion Nomographs (Figure 4 on page 12 and Figure 5 on page 13), without requiring the use of unwieldy and expensive slotted line equipment. Many users find that the ratio of forward to reflected power is more useful than VSWR.

Coupling Circuit

When the wattmeter is connected into the system, the RF power is directed through the unit's line section. The air line is a short, uniform section which does not impair the impedance of the RF coaxial line into which it is inserted. When the Plug-In Element is installed in the socket of the line section, the RF waves travelling through the line produce energy in the coupling circuit of the Plug-In Element by both inductance and capacitance (Figure 2 on page 7). The inductive currents will flow according to the direction of the travelling waves producing them. Therefore, assuming that the Plug-In Element remains stationary, the coupling currents produced from the waves of one direction add in phase, while those produced from the waves of the opposite direction subtract in phase. The additive or "arrow" direction is assigned to the forward wave. The element is designed so that the wave components travelling in the opposite direction of the arrow will nearly cancel each other out, making the element highly insensitive to the reverse wave direction. Because of the highly directional characteristics of the element, the resultant direct current sensed by the meter indicates the power level of only the RF waves travelling in the arrow direction.

The Plug-In Element is designed so that it can be rotated 180 degrees in its socket in the line section. When it is rotated, the wattmeter indicates the power in a direction opposite that of the initial reading. If the forward direction power is read first, the reflected direction power will be read after the Plug-In Element is rotated. The energy resulting from the inductively coupled component of the forward wave will bring about cancellation as described above.

Peak Power Operation

The Model 4314C is designed to measure peak power in addition to average power. When the toggle switch is placed in PEAK mode (Figure 3 on page 7), battery power energizes the amplifier system. If the AC adapter is being used, it energizes the relay and disengages the batteries.

The battery test circuit is energized when the push button switch is pressed. If the voltages of the two 9 V batteries are within the limits necessary to properly operate the amplifier circuit, the pointer of the meter deflects beyond the battery test mark on the meter scale. If the pointer fails to reach the mark, the batteries need replaced. Replacement of both batteries simultaneously will assure that sufficient battery power will be available for extended periods of time (see "Maintenance" on page 21). If the push button is pressed continuously for a length of time exceeding 10 seconds, the load will be disconnected from the batteries. This feature allows the batteries to maintain a charge even if the wattmeter's battery test button had been mistakenly pressed for a long period of time. After the load has been disconnected, the battery test reading will no longer be accurate.

The internal amplifier circuit is designed to provide current to the meter. The meter current indicates, at a steady state, the peak of the power applied to a load resistor at the input of the peak detect circuit. This input load resistor exactly matches the resistance of the meter, thus the existing circuit in the Element is loaded with the same current as the average reading mode (Figure 2 on page 7).

When the toggle switch is moved from CW to PEAK, the DC input that is normally applied to the meter is interrupted and is applied instead to an input load resistor. This input is then routed through a circuit that first amplifies and then holds the peak envelope power level detected. This peak power level is converted back to the proper level for the meter and is then displayed on the meter. Two variable resistors provide both zero and gain calibrations of the amplifier circuit.

The peak hold circuit continues to maintain the reading of the meter even though the peak of the pulse is no longer applied to the amplifier circuit. Only the peak power is indicated even though there is a wide fluctuation of input power. Because of a small amount of leakage designed into the peak hold circuit, there will be a decay that limits the time the amplifier system will retain its output level. As the circuit decays, the meter will return to zero if no additional pulses are received at the input load resistor.

Figure 2 Schematic Diagram - Element

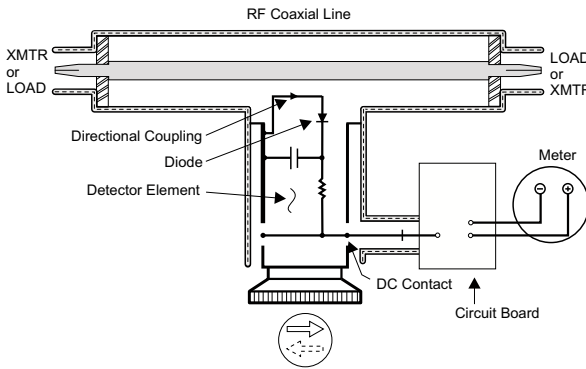

Component Description

Figure 3 Component Diagram

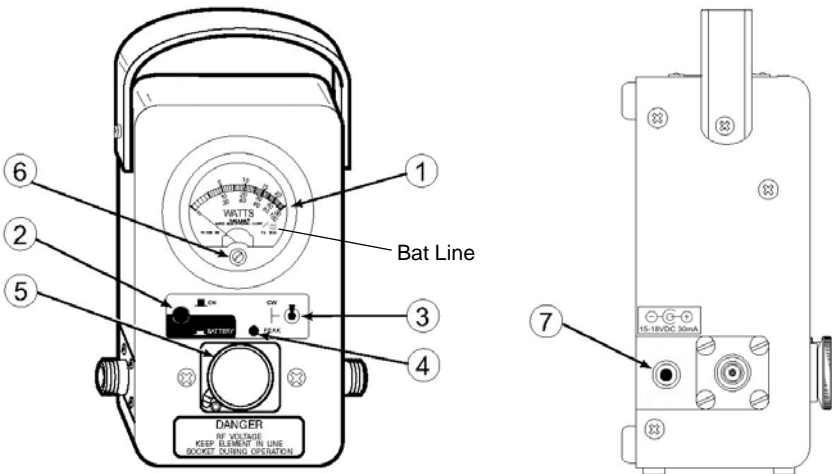

1	Meter
2	Battery Test Push Button
3	CW/PEAK Toggle Switch
4	PEAK Circuit Active Light
5	Element
6	Zero-Adjust Screw
7	DC Input Jack

Zero Adjust Meter

Before taking any readings with the wattmeter, it is necessary to zero the meter pointer under no-power conditions.

WARNING

Exposure to RF power radiation and the possibility of RF shock or burns exist with some operating conditions. Always be sure to turn off the transmitter when connecting or disconnecting a wattmeter.

Be sure the transmission line is terminated into a load or antenna. When a Plug-In Element is removed from the RF line socket, the line section center conductor is exposed. Do not put fingers or other objects into the Plug-In Element socket while RF power is applied.

CAUTION

Use reasonable care in handling. Do not drop or subject the wattmeter or elements to hard blows as accuracy may be impaired or other damage may result.

CAUTION

Do not apply RF power to the wattmeter in excess of the full scale range of the element.

1. Rotate Plug-In Element so that the arrow points down.
2. Set wattmeter's control to CW mode.
3. Using a small screwdriver, turn the meter's zero adjust screw (located in the bottom center of the meter) clockwise or counterclockwise.
4. Ensure the meter pointer aligns with the zero mark on the meter scale.

Plug-In Element Selection and Insertion

The elements determine the power range to be read on the meter scale. The major markings (50 W, 100 W, etc.) are the full scale power value for that element. Elements are also marked for frequency range.

Note: *The transmitter frequency must be within the band of the element used.*

- RF power measurements are made with the insertion of a Plug-In Element. Insert the element into the line section's socket.
- Forward power is indicated when the arrow on the element points in the direction of power flow; from transmitter to load. Reflected power measurements are made with the element rotated 180 and the arrow pointing towards the transmitter.

Note: *The element must be rotated fully when power measurements are being made.*

The index pin protruding from the element's body should rest against the stop on the line section in both the forward and reflected position. The small catch in the lower left hand corner of the casting face should press down on the shoulder of the Plug-In Element. This will keep the Plug-In Element in proper alignment and ensure good contact with the dc pickup, the lower edge of the element and the line section body.

Measurements

CW Power Measurements

1. Set the wattmeter control to CW mode.
2. Read the appropriate meter scale corresponding to the element full-scale value.

Example - *A 2500 Watt element would use the 25 scale, whereas a 5 Watt element would use the 50 scale.*

Peak Power Measurements

1. Press the ON/BATTERY button to test the battery voltage level.

Note: *If the pointer of the meter indicates below the battery test zone, the batteries must be replaced. See "Replacing the Batteries" on page 24.*

Note: *If the push button is pressed continuously for a length of time exceeding 10 seconds, the battery test load will be disconnected from the batteries. Do not read the battery level after this time because once the load has been disconnected, the battery test reading will no longer be accurate.*

2. Set CW/PEAK switch to PEAK mode.

Note: *The small indicating light to the left of "Peak" will be lit to show Peak Mode Operation.*

3. Read the appropriate meter scale corresponding to the element full-scale value.

Load Power

Where an appreciable amount of power is reflected, as with an antenna, it is necessary to subtract the reflected from the forward power to obtain the effective load power. Power delivered to and radiated by an antenna is given by:

$$W_1 = W_f - W_r$$

Where: $W_1 = \text{load power}$

$W_f = \text{ForwardPower}$

$W_r = \text{ReflectedPower}$

A load closely matched to 50 ohms resulting in a VSWR of 1.2 or less will require less than a one percent correction. A good RF load resistor, such as a Bird Termline Load Resistor, will produce this sort of negligible or unreadable reflected power.

The Model 4314C ThruLine Wattmeter used with a Bird Termline Load Resistor of proper power rating forms a highly useful absorption wattmeter. Since the reflected power will be negligible, it will be unnecessary to rotate the element from the forward direction.

Determining VSWR

The Model 4314C ThruLine Wattmeter is not designed to provide direct VSWR readings. In most cases, operators find that the ratio of forward to reflected power is of equal use. However, VSWR readings can be determined very easily by the use of the provided graphs as follows:

1. Determine the forward and reflected power as described above.
2. Using the appropriate VSWR Conversion Nomograph, determine the intersection of the forward and reflected power values.

Note: *The slanted line passing closest to this point indicates the VSWR.*

Figure 4 VSWR Conversion Nomograph

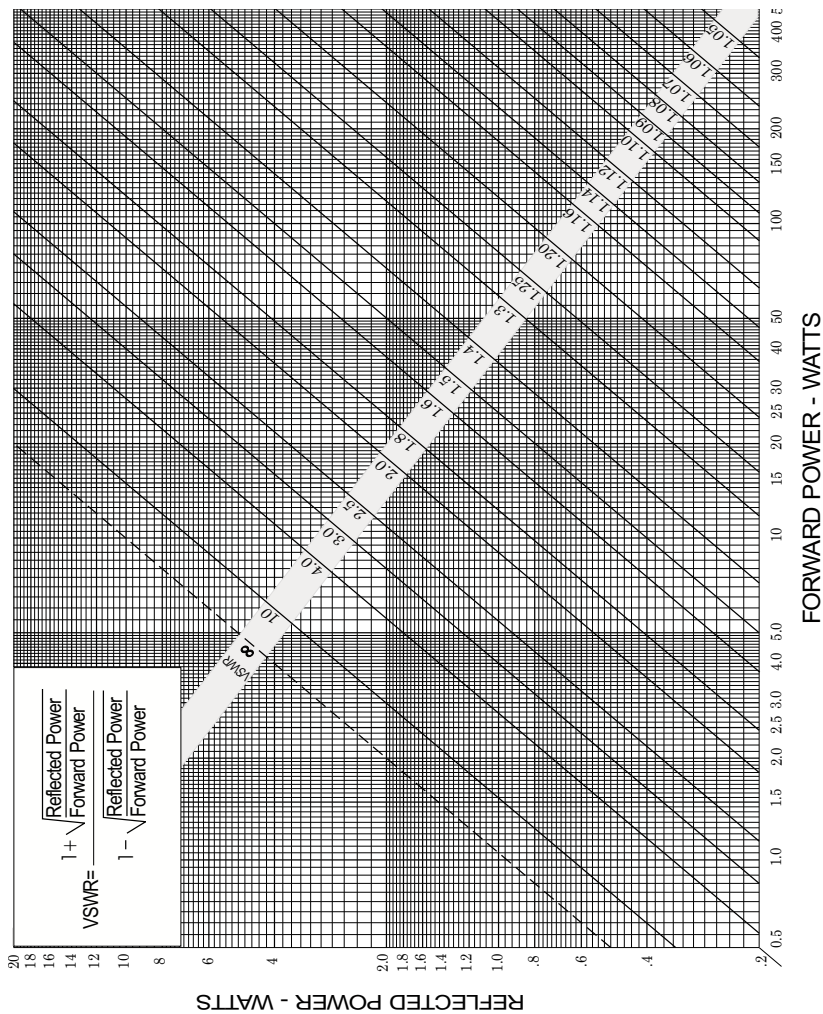
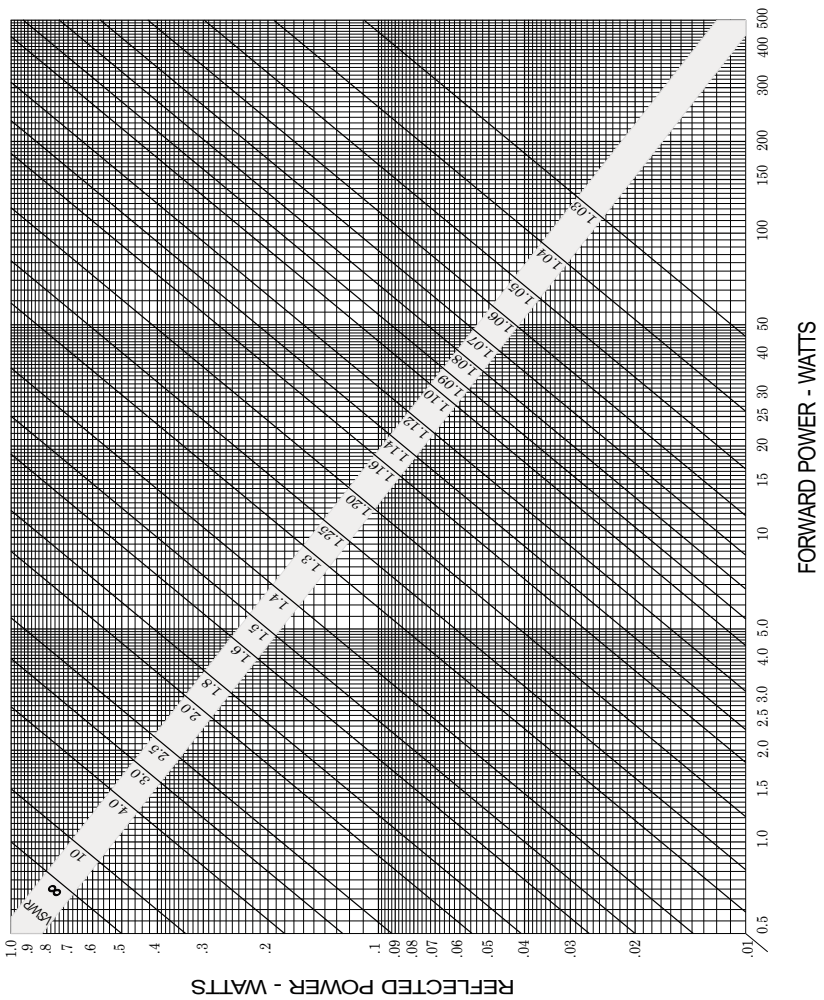

Figure 5 VSWR Conversion Nomograph



Making Low Reflection Readings

It is sometimes desirable to make more accurate low reflection readings. This can be done using a more sensitive element, provided that care is taken to prevent application of high forward power to the low-power element. This procedure is limited to use with higher power transmitters only.

1. Measure watts forward, using the proper Plug-In Element.
2. Reverse the arrow direction of the element to determine the general level of reflected power.
3. Remove the Plug-In Element.
4. Insert a lower power element which has a maximum rating of more than the reflected power indicated in the first measurement.
5. Insert the element, carefully, so that it reads reflected power only.

CAUTION

When making low reflection readings using a more sensitive element, take care to insert the element so that it senses reflected power only. Do not rotate the element in the socket so that it is subjected to forward power. This can result in damage to the Plug-In Element, the wattmeter, or both.

6. Read the reflected power on the meter in the usual manner.

Note: *When using the two-element method of reading low reflected power, it is not recommended to use a pair of elements which has a full scale power differential of greater than 10 to 1.*

Testing Lines, Connectors, Filters & Related Components

Lines, connectors, filters, and related components can be tested using the Thru-line Wattmeter. The method of testing depends upon the circumstances involved for any particular test. Some of these tests are listed below:

The standing wave ratio or the reflected-power to forward-power ratio of a line can be determined by terminating the line with a good load resistor, such as a Bird Terminal Load Resistor. Proceed as described under determining VSWR. Low reflected power may be measured as described above.

Line attenuation (power lost as heat in the line) can be determined by inserting the line of unknown value between two Thru-line Wattmeters. The end of the line must be terminated by a load resistor. The attenuation of the line can be determined by comparing readings made at the two ends. Allowances must be made for normal instrument error where very small values of attenuation are involved. Some correction may be made by direct rigid connection of the Thru-line Wattmeters.

Determining Attenuation with a Single Wattmeter

Note: *This measurement must be supplemented with a reflected power to forward power ratio check while using a load or with a DC continuity check or leakage check, since open circuits or shorts may exist part of the way along the line. The ratio determined in these tests should be viewed as a rough estimate, since 100% of the power at the open connector will not be reflected back.*

Open Circuit Method

1. Attach an RF generator to the wattmeter's input port.
2. Attach the section of transmission line that is to be measured to the output port.

Note: *The line section should be left open-ended.*

3. Apply power.
4. Measure the Forward Power (P_{fwd}).
5. Measure the Reflected Power.
6. Divide the Reflected Power reading in half to determine the Reflected Power in the transmission line (P_{rfl}).

Note: *Because the power drop is being measured twice (down and back).*

7. Convert the reading to decibels by using this equation:

$$dB = 10 \log \frac{P_{rfl}}{P_{fwd}}$$

Short Circuit Method

Perform the Open Circuit Method with the exception of using a Short standard on the end of the line being measured.

Note: *The open circuit method is preferred because the ratio (reflected power to forward power) is easier to achieve in an open circuit.*

Measuring Percentage Of Positive Modulation

To measure the percentage of positive modulation in an amplitude modulation system, employ the average and peak reading characteristics of the unit since:

$$\text{PercentagePosMod} = \frac{E_{MAX} - E_{CARRIER}}{E_{CARRIER}} \times 100$$

By substitution we get:

$$\text{PercentagePosMod} = \left(\frac{\sqrt{P_P} - \sqrt{P_C}}{\sqrt{P_C}} \right) \times 100$$

Where: P_P = peak power as read with CW/PEAK switch in PEAK mode.

P_C = carrier power as read with CW/PEAK switch in CW mode

Or:

$$\text{PercentagePosMod} = \left(\frac{\sqrt{\frac{P_P}{P_C}} - \sqrt{\frac{P_C}{P_C}}}{\sqrt{\frac{P_C}{P_C}}} \right) \times 100$$

And by cancellation:

$$\text{PercentagePosMod} = \left(\frac{\sqrt{\frac{P_P}{P_C}} - 1}{\sqrt{\frac{P_C}{P_C}}} \right) \times 100$$

After determining average and peak readings, find the intersection of the carrier and peak powers on Figure 6 on page 17 to determine the percentage of positive modulation.

Figure 6 Graph Converting Carrier Power and Peak Power to Percent

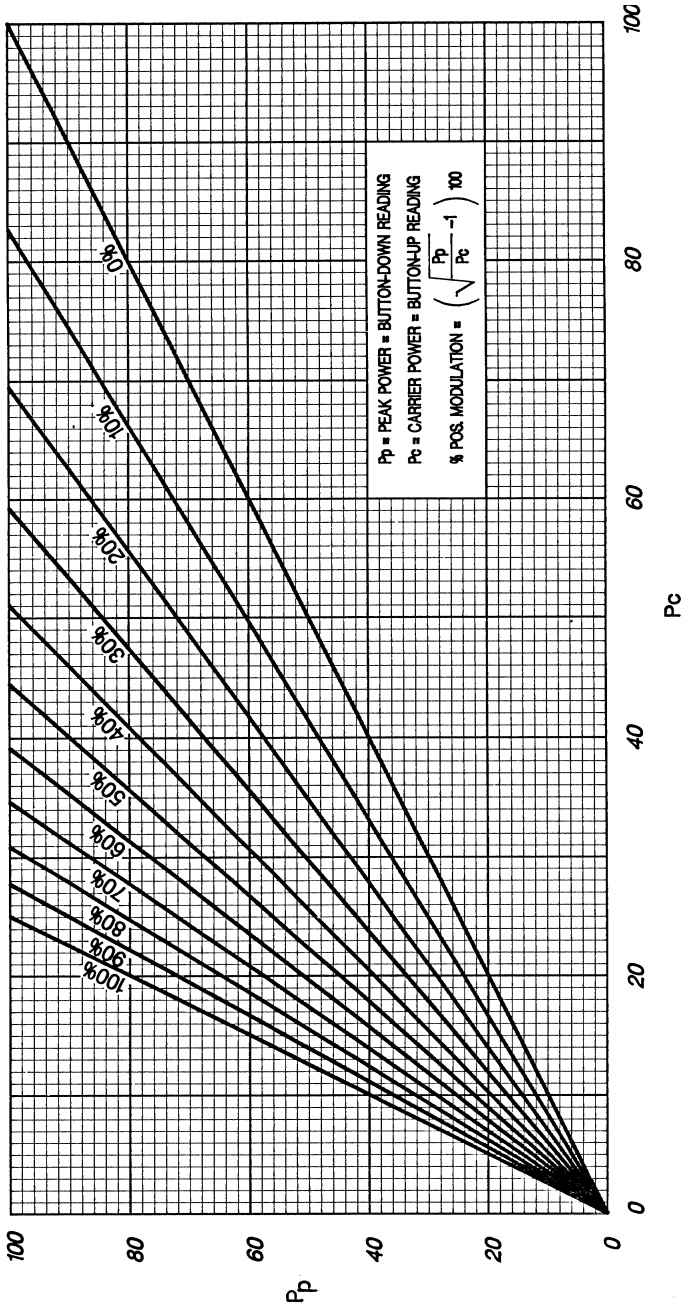

Performance Notes

Although the Model 4314C ThruLine Wattmeter is equipped with Quick-Change connectors, it must be remembered that the power rating and insertion loss may be affected if other than "N" type connectors are used. Power limits must be governed by the type of connector or transmission line used. For other types of Quick-Change connectors, see Chapter 5 for the replacement parts list.

When a Model 4314C is used to match a load to a transmitter and a good match is obtained, removing the instrument will not cause any change in the conditions. A well matched 50 ohm load can be placed at the end of a 50 ohm transmission line of any length without altering conditions at the transmitter.

When the load is not well matched, like an antenna with a VSWR of 1.5 or 2.0, line length becomes critical since the length of line between a mismatched load and the source transforms the impedance of the load as seen at the source. If the adjustments for maximum power transfer were made with the Model 4314C in place, removing it shortens the line by four inches plus two connectors. This still is no cause for concern at low frequencies where four to five inches is a small fraction of a wavelength. At higher frequencies; e.g., above 100 MHz, the power output and frequency of the source may be affected.

To ensure that the impedance is identical on either side of $\frac{1}{2}$ wavelength in the transmission line with the Model 4314C either in or out of the line, it is only necessary to insert or remove a $\frac{1}{2}$ wavelength.

Make up a length of cable which, when added to the ThruLine Wattmeter, equals $\frac{1}{2}$ wavelength at the frequency of measurement. If more than one frequency is involved, then a separate cable is needed for each frequency. Use Figure 7 on page 19 to determine the cable length required.

Note: *When using UHF Plug PL-259, the cable length is measured from tip to tip of center pin of plugs.*

Note: *When using other connectors, the cable length is measured from the ends of the outer conductor of the connectors.*

Figure 7 Cable Wavelength Matching Graph

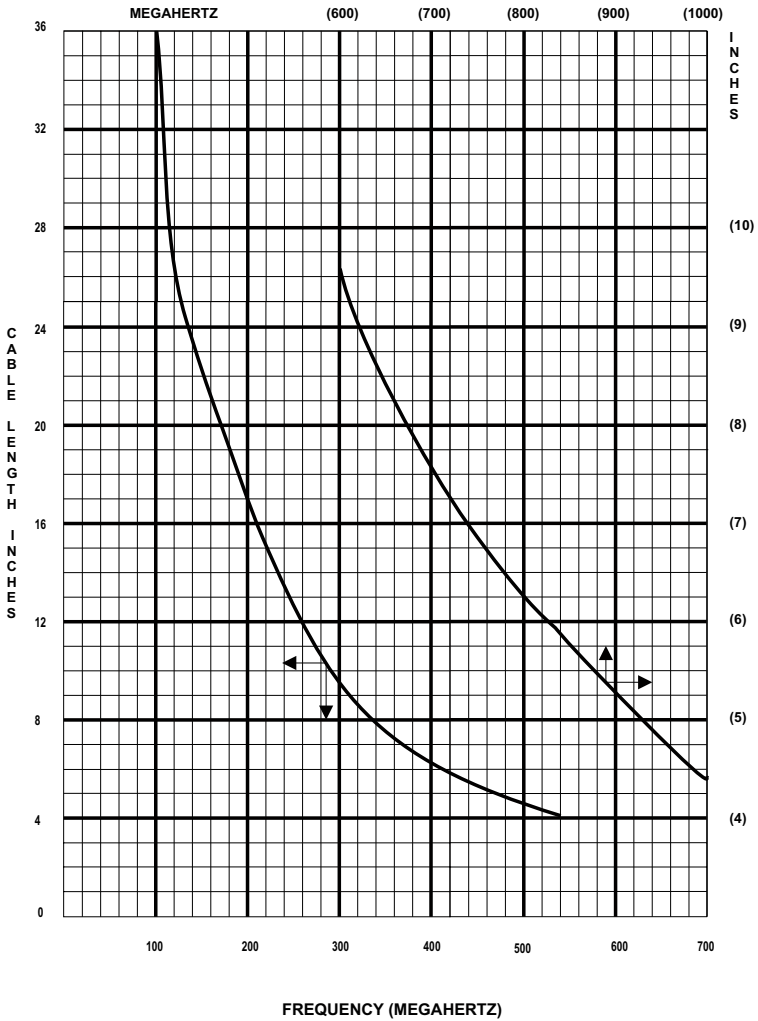

Shutdown

1. Ensure the CW/PEAK switch is in CW mode.

Note: Leaving the unit in PEAK mode will shorten battery life.

WARNING

Always be sure transmitter power is off before disconnecting the unit from the transmission line.

Cleaning

If any of the contacts or line connectors become dirty, they should be cleaned with a good contact cleaner or dry cleaning solvent on a cotton swab stick.

It is important to keep the following surfaces clean:

- Socket bore
- Element body circumference
- Bottom rim of the socket in the line section
- DC contacts on the element

Take care not to disturb the spring finger of the DC contact when cleaning the socket bore. The spring finger can be manually adjusted. The button must be pushed out far enough to make good contact with the element body but it must not restrict the entry of the element.

Clean the meter and meter housing using a cloth moistened with a mild detergent solution. Do this only when necessary and take care not to allow water to enter any of its circuitry as damage may result.

CAUTION

Use reasonable care in handling. Do not drop or subject the wattmeter or elements to hard blows as accuracy may be impaired or other damage could result.

Preventative Maintenance

Care and maintenance required for the 4314C ThruLine Wattmeter is primarily limited to cleaning. Keeping the Plug-In Element in the socket of the line section as much as possible serves as an effective seal against the entry of dust and dirt and to prevent damage to the meter. An aluminum dust plug may be used to cover the socket opening when the element is removed.

Line Section Care

The RF connectors on the line section should also be protected against the entry of dust and dirt by keeping them covered when the wattmeter is disconnected from the RF line.

If there is evidence of contamination inside the line section, the reachable portions should be cleaned and the interior carefully blown out.

Do not attempt to remove the RF center conductor under any circumstances. Any attempt to do so will damage the assembly.

Inspection

Periodic inspections should be performed at six-month intervals.

- Inspect the meter for a cracked meter glass.
- Inspect wattmeter line section for a damaged or missing latch and pivot pin assembly.
- Inspect all “QC” connectors for bent, broken, or missing pins.

Troubleshooting

Due to its complexity, field repair of the Model 4314C ThruLine Wattmeter is recommended only for certain malfunctions. Only those functions within the scope of normal maintenance are listed.

If a malfunction is not listed or not corrected by the listed corrective actions, notify a qualified service center for further instructions.

PROBLEM	POSSIBLE CAUSE	CORRECTION
No meter indication (CW or PEAK)	No radio frequency	Turn on transmitter.
	Faulty RF section assembly	Check transmitter operational conditions, refer to operating instruction manual of equipment used.
		Check connections, interconnecting cables, and auxiliary in-line equipment.
	Arrow on element pointing in wrong direction	Rotate element so that arrow points in direction of RF power flow.
	Meter burned out or damaged	Replace meter. See “Replacing the Meter” on page 25.
	No pick-up from DC contact	Clean line section and element. See “Cleaning” on page 21.
	Defective Plug-In Element	Check element. Replace element if defective.

PROBLEM	POSSIBLE CAUSE	CORRECTION
No meter indication (PEAK only)	Faulty instrumentation module	Replace the instrumentation module, see "Replacing the Instrumentation Module" on page 26.
	Dead or low battery	Test battery. See "Battery Procedures" on page 24. Replace if necessary. See "Replacing the Batteries" on page 24.
		If pointer does not move from zero during the battery test, remove the batteries and measure their voltage. If less than 6.25 volts, replace the batteries. See "Replacing the Batteries" on page 24.
Erroneous or inaccurate	Low battery	Press ON/BATTERY selector switch to the BATTERY position. If the battery test indicates weak batteries, replace them with new ones. See "Replacing the Batteries" on page 24.
	Shorted or opened cable	Check connections, in-line equipment, interconnecting cables, and auxiliary in-line equipment.
	Wattmeter out of calibration	Check calibration. See "Calibrating the Wattmeter" on page 28.
Intermittent or inconsistent	Faulty transmission line, line connections, antenna, or load conditions	Inspect and correct meter operation or load.
	Dirty line section, DC contact, and/or element	Clean line section and element. See "Cleaning" on page 21.
	Sticky meter	Replace meter. See "Replacing the Meter" on page 25.
High VSWR or high percentage reflected power	Bad load or poor load, antenna, or connectors	Replace connectors. See "Replacing the Instrumentation Module" on page 26.
	Shorted or open transmission line	Replace transmission line.
	Foreign material in line section or in RF connector bodies	Check for foreign material and clean as required. See "Replacing the Meter" on page 25.

Battery Procedures

Testing the Batteries

The Model 4314C Thruline Wattmeter uses two 9 V alkaline batteries to supply power for the peak circuitry.

1. Press the ON/BATTERY switch.

Note: *The meter pointer should travel to the right of the “BAT.TEST” mark.*

2. If the pointer stops below the mark, replace the batteries.

Note: *If the push button is pressed continuously for a length of time exceeding 10 seconds, the battery test load will be disconnected from the batteries. Do not read the battery level after this time because once the load has been disconnected, the battery test reading will no longer be accurate.*

Replacing the Batteries

1. Remove the back cover by unscrewing the four 8-32 Phillips flat head screws.

Note: *The screws are located two on each side of the meter housing near the back edge at the top and bottom of the sides.*

2. Pull the cover straight off.
3. Rotate the battery in its clip, then pull upward freeing the battery.
4. Remove the snap-on battery connector.
5. Insert the battery into the clip and replace.
6. Repeat above procedure for the other battery.

Figure 8 *Replacing the Batteries*

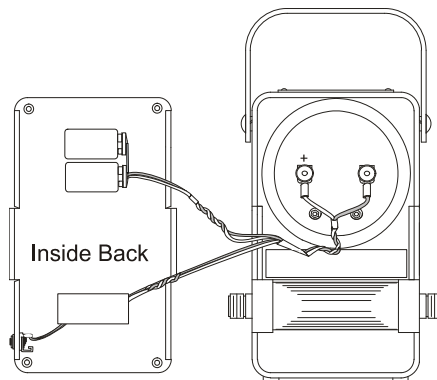

Replacing the Meter

1. Remove the back cover by unscrewing the four 8-32 Phillips flat head screws.

Note: *The screws are located two on each side of the meter housing near the back edge at the top and bottom of the sides.*

2. Loosen the two 8-32 nuts securing the meter leads.
3. Remove the meter leads.
4. Remove the two 10-32 oval head Phillips screws securing the meter shock ring.
5. Pull the meter and shock ring assembly out of the housing from the back.

Note: *If the three rubber shock mount buttons, P/N 4420-098, that the meter rests on are to be reused, be careful not to lose them. However, if the replacement shock ring, P/N 4410A261, is to be used instead, the buttons may be discarded.*

6. Remove the meter retaining ring and shock mount from the meter.
7. Replace the meter.

Note: *If the replacement shock ring is used, peel off the white strip covering the adhesive backing. Carefully adhere the shock ring to the front bezel flange.*

Note: *Be sure to observe the polarity when replacing the leads to the meter, black to negative, orange to positive.*

8. Zero adjust the meter by turning the adjustment screw found on the front bottom center of the meter face.

Figure 9 Replacing the Meter

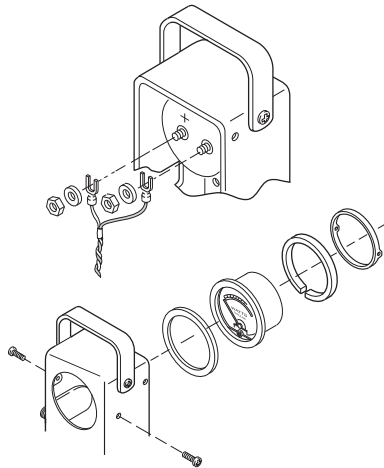

Replacing the Instrumentation Module

CAUTION

This instrument contains static sensitive electronic components. Before opening or servicing the unit, make sure that you understand and practice electrostatic discharge component handling. Failure to comply may result in permanent damage to sensitive components.

1. Remove the back as above in meter replacement.

Note: *The instrumentation module contains the line section and circuit board chassis as an integral part.*

2. Loosen the dress nut on the CW/PEAK switch.

Note: *Care should be taken not to scratch the label.*

3. Remove the wire assemblies from the batteries, meter, and DC jack.

4. Remove the battery wires (item 7) first at the printed circuit board by pulling up on the connector.

5. Remove the DC jack wires (item 5).

6. Remove the meter wires (item 3) also at the printed circuit board.

Note: *Care should be taken not to break the wires.*

Note: *Note the wire location for ease of reassembly.*

7. Remove the two oval head Phillips screws located on the front face of the unit on either side of the line section element socket.

8. Pull the instrumentation module straight out from the back of the unit.

9. Replace the instrumentation module by reversing steps 1 - 8.

10. Zero Adjust the wattmeter. See "PEAK Mode Zero Adjust" on page 28.

CAUTION

If other than Female N type connectors are used, limit power and frequency to the capabilities of the RF coaxial cable or connectors used. Damage to connectors or errors in reading could result.

Figure 10 Replacing the Instrumentation Module

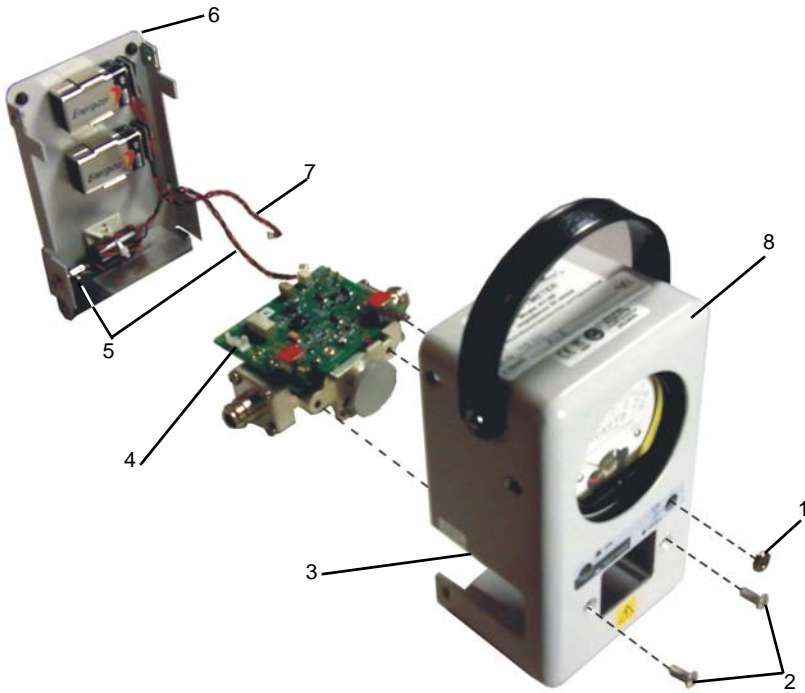

1	Dressnut
2	Mounting Screws
3	Meter Wire Assembly (hidden from view)
4	Instrumentation Module
5	DC Jack Assembly
6	Housing Cover Assembly
7	Battery Cable Assembly
8	Housing Assembly

Replacing the Quick-Change Connectors

1. Remove the four 8-32 screws from each corner of the square flange on the connector.
2. Pull the connector straight outward.
3. Install the new connector by reversing this procedure.

Calibrating the Wattmeter

The 4314C requires a total of three calibrations to set zero and gain. These calibrations must be performed after the meter or instrumentation module has been replaced. Additionally, a mechanical zero adjustment of the meter pointer is done any time the pointer is not exactly aligned with the zero mark on the meter scale when no power is being applied in CW mode.

Note: *Before beginning this procedure, a DC Input element (4381-050) is needed.*

PEAK Mode Zero Adjust

To ensure that the meter reads correctly for both CW and PEAK operation:

1. Short the input by doing one of the following:
 - Insert a dust plug
 - Position a standard element with the arrow pointing down
2. Set the CW/PEAK switch to CW mode.
3. Ensure the pointer rests at 0.

Note: *If the pointer needs to be adjusted, zero the pointer by turning the mechanical zero adjustment screw located at the bottom front center of the meter face. See "Zero Adjust Meter" on page 9*

4. Set the CW/PEAK switch to PEAK mode.
5. Attach a voltmeter to the posts on the back of the meter.
6. Set the voltmeter to read in mV scale.
7. Slowly adjust the "ZERO ADJ." potentiometer with a small screwdriver (Figure 11 on page 29) until the reading shown on the voltmeter is 0.0mV.
8. Ensure that the pointer rests at 0.

Note: *There should be no pointer position variation between CW and PEAK modes.*

PEAK Mode Gain Adjust

1. Remove the dust plug standard element, if present.
2. Insert DC Input element (4381-050) into the line socket.
3. Apply approximately 34 mV from a DC power supply to the connector on the DC Input element.

Note: *If a non-adjustable voltage supply is being used, install a voltage dividing potentiometer in series.*

4. If necessary, adjust the "GAIN ADJ." potentiometer with a small screwdriver (Figure 11 on page 29) so that the same reading is attained in both CW and PEAK modes.

Note: This can be verified on both the voltmeter display and the meter face.

Note: Set the CW/PEAK switch to PEAK mode while watching the meter pointer. The pointer should deviate or travel about 4/5 scale. There should be no deviation of the pointer from CW to PEAK reading.

Figure 11 Calibration Potentiometer

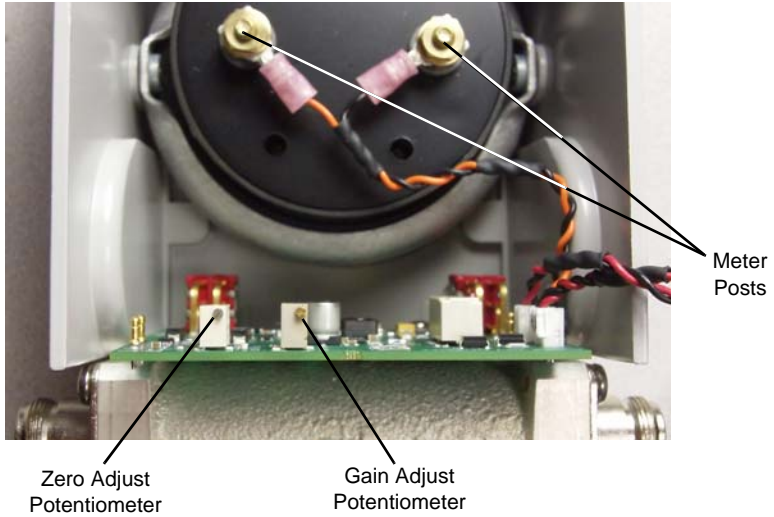
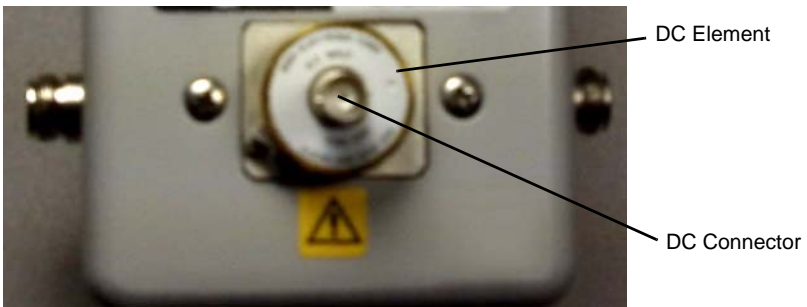

Figure 12 DC Element Input



Customer Service

Any maintenance or service procedure beyond the scope of those in this chapter should be referred to a qualified service center.

If you need to return the unit for any reason, request an RMA through the Bird Technologies website (link shown below). All instruments returned must be shipped prepaid and to the attention of the RMA number.

Bird Service Center

30303 Aurora Road
Cleveland (Solon), Ohio 44139-2794
Fax: (440) 248-5426
E-mail: bsc@bird-technologies.com

For the location of the Sales Office nearest you, visit our website at:

<http://www.bird-technologies.com>

Specifications

Impedance	50 ohms nominal
Insertion VSWR With "N" Connectors	1.05 Max. to 1000 MHz, 1.1 Max. to 2300 MHz
Connectors	Bird Quick Change "QC" Female N normally supplied'
RF Power Ranges Average (CW) Mode Peak-pulse or envelope-power (PEAK) Mode	100 mW to 10 kilowatts ($\pm 5\%$ of full scale) 100 mW to 10 kilowatts ($\pm 8\%$ of full scale)
Frequency Range	0.45 to 2700 MHz (either mode)
Pulse Parameters Minimum duty factor Minimum repetition rate Minimum pulse width	1.0 x 10 ⁻⁴ 30 pps 0.4 microseconds at 100-2300 MHz 1.5 microseconds at 26-99 MHz 15 microseconds at 2-25 MHz
Weight (Approx.)	4 lb. (1.8 kg) with N-Connectors
Dimensions	3-5/8"L x 4"W x 7"H (92.1 x 102 x 178 mm)
AC Power Requirements (using adapter)*	100-240 +/- 10% VAC @ 50/60Hz
Batteries	Two 9 V alkaline
Battery Life	20 hours of operation, typically

*. Use only adapter supplied by Bird Technologies Group.

Replacement Parts

Note: For this table, refer to Figure 13 on page 33.

Item	Quantity	Description	Part Number
1	1	Housing assembly	4314-103
2	1	Instrumentation module	4314A202
3	1	Meter	2080-044
4	1	Battery cable assembly	4314A116
5	1	DC jack wire assembly	4314A117
6	1	Meter wire assembly	4314-119
7	2	9 V battery	5-1375
8	2	"QC" connectors	(Female N normally supplied)*
9	1	Housing cover assembly	4314A114
10	1	Dress nut (not shown)	5-1670
11	1	AC to DC converter (not shown)	5B2229-156E

*Available QC Type Connectors

Connector	Part Number
N-Female	4240-062
N-Male	4240-063
HN-Female	4240-268
HN-Male	4240-278
LC-Female	4240-031
LC-Male	4240-025
BNC-Female	4240-125
BNC-Male	4240-132
LT-Female	4240-018
LT-Male	4240-012
C-Female	4240-100
C-Male	4240-110
UHF-Female (SO-239)	4240-050
UHF-Male (PL-259)	4240-179
7/8" EIA Air Line	4240-002

Figure 13 Replacement Parts

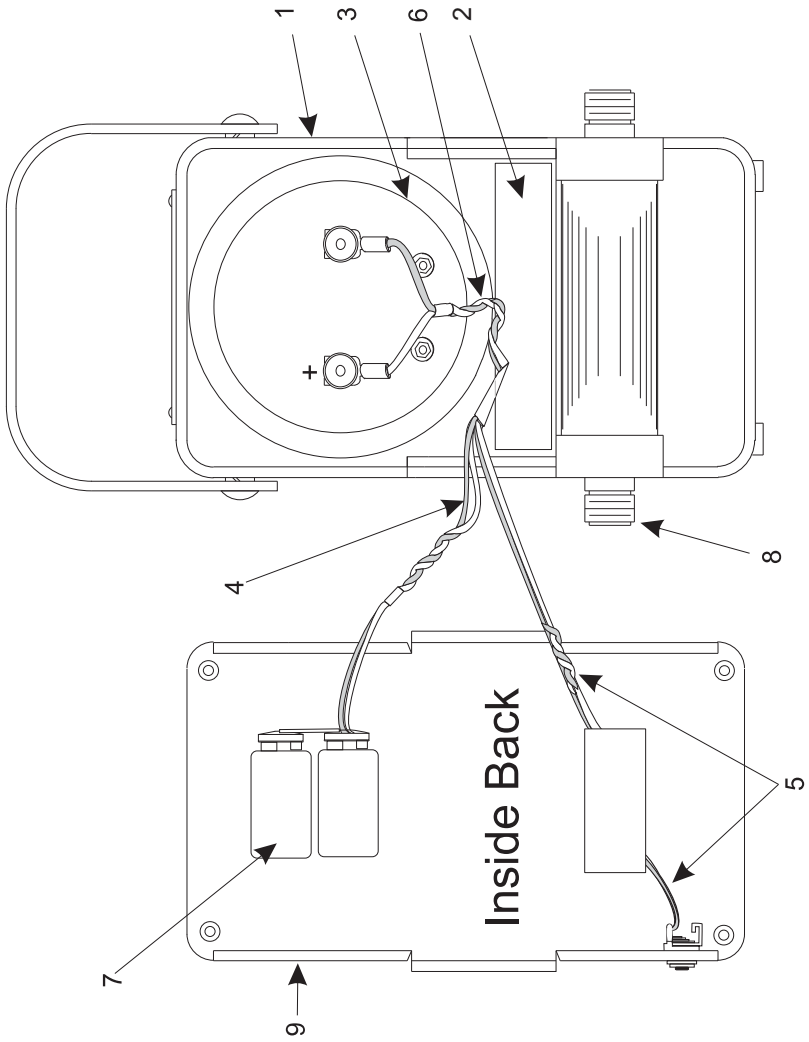

LIMITED WARRANTY

All products manufactured by Seller are warranted to be free from defects in material and workmanship for a period of one year, unless otherwise specified, from date of shipment and to conform to applicable specifications, drawings, blueprints and/or samples. Seller's sole obligation under these warranties shall be to issue credit, repair or replace any item or part thereof which is proved to be other than as warranted; no allowance shall be made for any labor charges of Buyer for replacement of parts, adjustment or repairs, or any other work, unless such charges are authorized in advance by Seller.

If Seller's products are claimed to be defective in material or workmanship or not to conform to specifications, drawings, blueprints and/or samples, Seller shall, upon prompt notice thereof, either examine the products where they are located or issue shipping instructions for return to Seller (transportation-charges prepaid by Buyer). In the event any of our products are proved to be other than as warranted, transportation costs (cheapest way) to and from Seller's plant, will be borne by Seller and reimbursement or credit will be made for amounts so expended by Buyer. Every such claim for breach of these warranties shall be deemed to be waived by Buyer unless made in writing within ten days from the date of discovery of the defect.

The above warranties shall not extend to any products or parts thereof which have been subjected to any misuse or neglect, damaged by accident, rendered defective by reason of improper installation or by the performance of repairs or alterations outside of our plant, and shall not apply to any goods or parts thereof furnished by Buyer or acquired from others at Buyer's request and/or to Buyer's specifications. Routine (regularly required) calibration is not covered under this limited warranty. In addition, Seller's warranties do not extend to the failure of tubes, transistors, fuses and batteries, or to other equipment and parts manufactured by others except to the extent of the original manufacturer's warranty to Seller.

The obligations under the foregoing warranties are limited to the precise terms thereof. These warranties provide exclusive remedies, expressly in lieu of all other remedies including claims for special or consequential damages. SELLER NEITHER MAKES NOR ASSUMES ANY OTHER WARRANTY WHATSOEVER, WHETHER EXPRESS, STATUTORY, OR IMPLIED, INCLUDING WARRANTIES OF MERCHANTABILITY AND FITNESS, AND NO PERSON IS AUTHORIZED TO ASSUME FOR SELLER ANY OBLIGATION OR LIABILITY NOT STRICTLY IN ACCORDANCE WITH THE FOREGOING.

