



**MULTI-PURPOSE
THRULINE® WATTMETER
RF POWER ANALYST®
MODEL 439 I A**

**CABLE AND ANTENNA TESTER
FOR WIRELESS SYSTEMS**

OPERATING INSTRUCTIONS

©COPYRIGHT 2012 BY BIRD ELECTRONIC CORPORATION
INSTRUCTION BOOK PART NUMBER 920-439 I A REV. K

THRULINE® AND POWER ANALYST® ARE REGISTERED TRADEMARK OF
BIRD ELECTRONIC CORPORATION

Safety Precautions

The following are general safety precautions that are not necessarily related to any specific part or procedure, and do not necessarily appear elsewhere in this publication. These precautions must be thoroughly understood and apply to all phases of operation and maintenance.

WARNING

Keep Away From Live Circuits

Operating Personnel must at all times observe general safety precautions. Do not replace components or make adjustments to the inside of the test equipment with the high voltage supply turned on. To avoid casualties, always remove power.

WARNING

Shock Hazard

Do not attempt to remove the RF transmission line while RF power is present.

WARNING

Do Not Service Or Adjust Alone

Under no circumstances should any person reach into an enclosure for the purpose of service or adjustment of equipment except in the presence of someone who is capable of rendering aid.

WARNING

Safety Earth Ground

An uninterruptible earth safety ground must be supplied from the main power source to test instruments. Grounding one conductor of a two conductor power cable is not sufficient protection. Serious injury or death can occur if this grounding is not properly supplied.

WARNING

Resuscitation

Personnel working with or near high voltages should be familiar with modern methods of resuscitation.

WARNING

Remove Power

Observe general safety precautions. Do not open the instrument with the power on.

Safety Symbols

WARNING

Warning notes call attention to a procedure, which if not correctly performed, could result in personal injury.

CAUTION

Caution notes call attention to a procedure, which if not correctly performed, could result in damage to the instrument.



The caution symbol appears on the equipment indicating there is important information in the instruction manual regarding that particular area

Note: *Calls attention to supplemental information.*

Warning Statements

The following safety warnings appear in the text where there is danger to operating and maintenance personnel, and are repeated here for emphasis.

WARNING

Use only Nickel Metal Hydride (NiMH) batteries that have a minimum capacity of 4500 milliamper hours (mAh). Do not install batteries that are not Nickel Metal Hydride. Do not install NiMH batteries that have less than 4500 mAh capacity. Failure to comply may result in damage to the batteries, damage to the instrument, and injury to personnel from battery chemicals.

On pages 16 and 18.

WARNING

Use dry cleaning solvents in a well ventilated area. Avoid excessive inhalation of solvent fumes, since they can be toxic in heavy concentrations. Always wear eye protection and avoid skin contact with the solvent.

On pages 17.

WARNING

Ensure that the power cable is unplugged before opening the wattmeter case. The power supply capacitor, C1, can retain a dangerous charge that must be removed before touching. Always have another person standing by who is trained in electric shock first aid.

On pages 22.

Caution Statements

The following equipment cautions appear in the text and are repeated here for emphasis.

CAUTION

Long-term storage of this instrument can affect battery performance and reduce battery life. Do not store the instrument for long periods of time without recharging the batteries (refer to page 18). Failure to comply may result in reduced battery charge and shortened battery life.

On pages 7 and 16.

CAUTION

Always be certain the 115/230 voltage selector is set to the proper voltage before AC power is applied.

On page 7.

CAUTION

Never apply RF power to the Model 4391A Wattmeter unless both line section sockets are filled with either an element or a dust plug. If an element is used it is advisable to place the element with the arrow at a 90° angle to the coaxial line.

On page 9.

CAUTION

Always disconnect AC power before opening the Model 4391 enclosure. Removal of at least one battery cell is also recommended when servicing the instrument.

On page 9.

CAUTION

If the element cannot be fully inserted into the socket, do not force it. You might damage the element.

On page 20.

CAUTION

This instrument contains static sensitive electronic components. Before opening or servicing the unit, make sure that you understand and practice electrostatic discharge component handling. Failure to comply may result in permanent damage to sensitive components.

On page 22.

Safety Statements

USAGE

ANY USE OF THIS INSTRUMENT IN A MANNER NOT SPECIFIED BY THE MANUFACTURER MAY IMPAIR THE INSTRUMENT'S SAFETY PROTECTION.

USO

EL USO DE ESTE INSTRUMENTO DE MANERA NO ESPECIFICADA POR EL FABRICANTE, PUEDE ANULAR LA PROTECCIÓN DE SEGURIDAD DEL INSTRUMENTO.

BENUTZUNG

WIRD DAS GERÄT AUF ANDERE WEISE VERWENDET ALS VOM HERSTELLER BESCHRIEBEN, KANN DIE GERÄTESICHERHEIT BEEINTRÄCHTIGT WERDEN.

UTILISATION

TOUTE UTILISATION DE CET INSTRUMENT QUI N'EST PAS EXPLICITEMENT PRÉVUE PAR LE FABRICANT PEUT ENDOMMAGER LE DISPOSITIF DE PROTECTION DE L'INSTRUMENT.

IMPIEGO

QUALORA QUESTO STRUMENTO VENISSE UTILIZZATO IN MODO DIVERSO DA COME SPECIFICATO DAL PRODUTTORE LA PROZIONE DI SICUREZZA POTREBBE VENIRNE COMPROMESSA.

SERVICE

SERVICING INSTRUCTIONS ARE FOR USE BY SERVICE - TRAINED PERSONNEL ONLY. TO AVOID DANGEROUS ELECTRIC SHOCK, DO NOT PERFORM ANY SERVICING UNLESS QUALIFIED TO DO SO.

SERVICIO

LAS INSTRUCCIONES DE SERVICIO SON PARA USO EXCLUSIVO DEL PERSONAL DE SERVICIO CAPACITADO. PARA EVITAR EL PELIGRO DE DESCARGAS ELÉCTRICAS, NO REALICE NINGÚN SERVICIO A MENOS QUE ESTÉ CAPACITADO PARA HACERLO.

WARTUNG

ANWEISUNGEN FÜR DIE WARTUNG DES GERÄTES GELTEN NUR FÜR GESCHULTES FACHPERSONAL.

ZUR VERMEIDUNG GEFÄHRLICHE, ELEKTRISCHE SCHOCKS, SIND WARTUNGSARBEITEN AUSSCHLIEßLICH VON QUALIFIZIERTEM SERVICEPERSONAL DURCHZUFÜHREN.

ENTRETIEN

L'EMPLOI DES INSTRUCTIONS D'ENTRETIEN DOIT ÊTRE RÉSERVÉ AU PERSONNEL FORMÉ AUX OPÉRATIONS D'ENTRETIEN. POUR PRÉVENIR UN CHOC ÉLECTRIQUE DANGEREUX, NE PAS EFFECTUER D'ENTRETIEN SI L'ON N'A PAS ÉTÉ QUALIFIÉ POUR CE FAIRE.

ASSISTENZA TECNICA

LE ISTRUZIONI RELATIVE ALL'ASSISTENZA SONO PREVISTE ESCLUSIVAMENTE PER IL PERSONALE OPPORTUNAMENTE ADDESTRATO. PER EVITARE PERICOLOSE SCOSSE ELETTRICHE NON EFFETTUARE ALCUNA RIPARAZIONE A MENO CHE QUALIFICATI A FARLA.

UNITS ARE EQUIPPED WITH RECHARGEABLE BATTERIES.

THESE ARE TO BE REPLACED BY AUTHORIZED SERVICE PERSONNEL ONLY!!!

LAS UNIDADES VIENEN EQUIPADAS CON BATERIAS RECARGABLES.

¡¡¡Y SOLAMENTE EL PERSONAL DE SERVICIO AUTORIZADO PUEDE REEMPLAZARLAS!!!

GERÄTE SIND MIT WIEDER AUFLADBAREN BATTERIEN BESTÜCKT.

BATTERIEN SIND NUR VON QUALIFIZIERTEM SERVICE PERSONAL AUSZUWECHSELN!!!

CES DISPOSITIFS SONT ÉQUIPÉS DE BATTERIES RECHARGEABLES.

SEUL LE PERSONNEL D'ENTRETIEN AUTORISÉ EST HABILITÉ À LES REMPLACER !

LE UNITÀ SONO DOTATE DI BATTERIE RICARICABILI,

CHE DEVONO DA COME SPECIFICATO DAL PRODUTTORE LA PROTEZIONE DI SICUREZZA POTREBBE VENIRNE COMPROMESSA.

USE CORRECT VOLTAGE SETTING AND FUSE - SEE MANUAL.

UTILISER UNE TENSION ET UN FUSIBLE CORRECTS - CONSULTER LE MODE D'EMPLOI.

USE LA INSTALACION Y FUSIBLE DE VOLTAJE CORRECTO - VEA EL MANUAL.

AUSSCHLIESSLICH VORSCHRIFTSMÄSSIGE WECHSELSPANNUNGS-EINSTELLUNG UND SICHERUNG BENUTZEN - SIEHE DAZU HANDBUCH.

UTILIZZARE TENSIONE E FUSIBLE ADATTI - FARE RIFERIMENTO AL MANUALE.

BE SURE THE 115/230V AC VOLTAGE SELECTOR IS SET TO THE PROPER LINE VOLTAGE, AND THE CORRECT AC LINE FUSE IS INSTALLED BEFORE AC POWER IS APPLIED.

S'ASSURER QUE LE SÉLECTEUR DE TENSION 115/230V C.A. EST BIEN RÉGLÉ POUR LA TENSION DU RÉSEAU ET QUE LE FUSIBLE DE LIGNE C.A. CORRECT EST EN PLACE AVANT DE METTRE SOUS TENSION C.A.

CERCIORESE QUE EL SELECTOR DE VOLTAJE DE 115/230V CA ESTE COLOCADO A LA LINEA DE VOLTAJE APROPIADA Y QUE EL FUSIBLE ESTE INSTALADO A LA LINEA CA ANTES DE APLICAR LA CORRIENTE ALTERNA.

VOR EINSCHALTEN DER WECHSELSTROMZUFUHR SICHERSTELLEN, DASS DER 115/230V WECHSELSPANNUNGS-SELEKTOR AUF DIE VORSCHRIFTSMÄSSIGE LEITUNGSSPANNUNG EINGESTELLT UND DIE RICHTIGE WECHSELSTROM-HAUPTSICHERUNG EINGESETZT IST.

PRIMA DI EROGARE CORRENTE, ASSICURARSI CHE IL SELETTORE DI VOLTAGGIO 115/230 V.C.A. SIA REGOLATO CORRETTAMENTE E CHE IL FUSIBLE ADATTO ALLA LINEA DI ALIMENTAZIONE C.A. SIA INSTALLATO.

RF VOLTAGE MAY BE PRESENT IN RF ELEMENT SOCKET - KEEP ELEMENT IN SOCKET DURING OPERATION.

DE LA TENSION H.F. PEAT ÊTRE PRÉSENTE DANS LA PRISE DE L'ÉLÉMENT H.F. - CONSERVER L'ÉLÉMENT DANS LA PRISE LORS DE L'EMPLOI.

HF-SPANNUNG KANN IN DER HF-ELEMENT-BUCHSE ANSTEHEN - ELEMENT WÄHREND DES BETRIEBS EINGESTÖPSELT LASSEN.

PUEDA HABER VOLTAJE RF EN EL ENCHUFE DEL ELEMENTO RF - MANTENGA EL ELEMENTO EN EL ENCHUFE DURANTE LA OPERACION.

IL PORTAELEMENTO RF PUÒ PRESENTARE VOLTAGGIO RF - TENERE L'ELEMENTO NELLA PRESA DURANTE IL FUNZIONAMENTO.

About This Manual

This manual covers the operating and maintenance instructions for the following models:

4391A

Changes to this Manual

We have made every effort to ensure this manual is accurate. If you discover any errors, or if you have suggestions for improving this manual, please send your comments to our Solon, Ohio factory. This manual may be periodically updated. When inquiring about updates to this manual refer to the part number and revision on the title page.

Chapter Layout

Introduction - Introduces the external features and functions of the unit, equipment provided, and options available.

Theory of Operation - Describes the overall operation of the circuitry and the instrument functions.

Installation - Provides information about connecting the instrument to your equipment.

Operation - All instructions necessary to operate the equipment, are contained in this section.

Maintenance - If a failure should occur, the troubleshooting section will aid in isolating and repairing the failure.

Parts - For location of major assemblies or parts refer to the part lists and associated drawings.

TABLE OF CONTENTS

Safety Precautions	0
Safety Symbols	i
Warning Statements	i
Caution Statements	ii
Safety Statements	iii
About This Manual	viii
Changes to this Manual	viii
Chapter Layout	viii
Chapter 1 Introduction	1
Purpose and Function	1
Description	2
Chapter 2 Theory of Operation	3
Description of Operation	3
Keyboard, Range Switches, and Display Group	3
Elements, Analog Circuitry, and A/D Converter	4
Chapter 3 Installation	7
Operating on AC Power	7
Connections	8
Chapter 4 Operating Instructions	9
Operating Modes	9
Reading Forward CW Power	9
Reading Reflected CW Power	10
Reading SWR	10
Measuring Peak Envelope Power	11
Measuring Amplitude Modulation	12
Measuring Power in dBm	13
Measuring Return Loss	13
Insertion Loss or Attenuation	14
Monitoring Maximum and Minimum Readings	14
Using the Peaking Aid	15
Battery Care	15

Chapter 5 Maintenance	17
Preventive Maintenance	17
Cleaning and Inspection	17
Long-term Storage	18
Calibration	18
Required Equipment	18
Initial Setup	19
Element Wiper Contact Adjustment	20
Troubleshooting	21
General	21
Disassembly	22
Front Panel Removal	23
Main Printed Circuit (PC) Board Removal	23
QC Connectors Removal	24
Line Section Removal	24
Battery Replacement	26
Parts List	28
Customer Service	31
Specifications	32
Limited Warranty	34

The Model 4391A is a multi-purpose Radio Frequency wattmeter designed around a microcomputer. A program stored in permanent memory controls the operation of the instrument at all times, permitting the detection and correction of various error sources and the refinement of the raw data produced by the directional detectors. The instrument can compute VSWR, amplitude modulation, and various decibel variables reducing the odds of error and making such measurements consistent or repeatable regardless of who makes the measurement.

Other benefits include extended range using standard elements in some modes of operation, continuous monitoring of maximum and minimum readings, a peaking aid, and error messages.

Because of its complexity, the proper use of the 4391A is not always obvious. For this reason it is strongly advised that this manual be read in its entirety before using the device.

Purpose and Function

The 4391A RF Power Analyst is an insertion type digital RF Directional ThruLine® Wattmeter designed to measure peak or average power flow, load match, and amplitude modulation in 50 ohm coaxial transmission lines. It is intended for use with CW, AM, FM, SSB, TV, and Pulse modulation envelopes. The instrument directly reads PEP or CW power in watts, milliwatts, or kilowatts in 9 ranges from 2.5 to 1000 full scale forward power and 0.25 to 100 full scale reflected power depending on the Plug-in Element. In addition it reads SWR directly over the range of 1.00 to 99.99, percent modulation directly over the range of 0.0 to 99.9, and return loss over the range of 0 to 36.1 dB. For convenience, forward and reflected CW power can be displayed in dBm (dB above 1 milliwatt) from 6 dB above to 24 dB below nominal element range.

Power range and frequency band are determined by the Plug-in Elements used. Two switches on the front panel of the instrument are set by the user to correspond to the nominal power range of the forward element. The reflected element is assumed to have a nominal range one tenth that of the forward element.

In any mode of operation, the instrument can recall from memory the lowest or highest reading taken or tell the operator whether the newest reading is less than, equal to, or greater than the previous reading.

Description

The instrument is housed in an aluminum case approximately 4-3/8 inches high by 9-5/8 inches deep by 6-1/4 inches wide (111 mm x 244 mm x 159 mm) including connections, see Figure 1. At each end of the line section are Bird Quick-Change type RF connectors which may be easily interchanged with any other Bird QC connector. See Bird Catalog for types available.

Operating power is derived from rechargeable nickel metal hydride batteries inside the unit or from a 115/230 VAC power source connected to the unit through the power cord supplied with the unit.

Figure 1 Outline Drawing

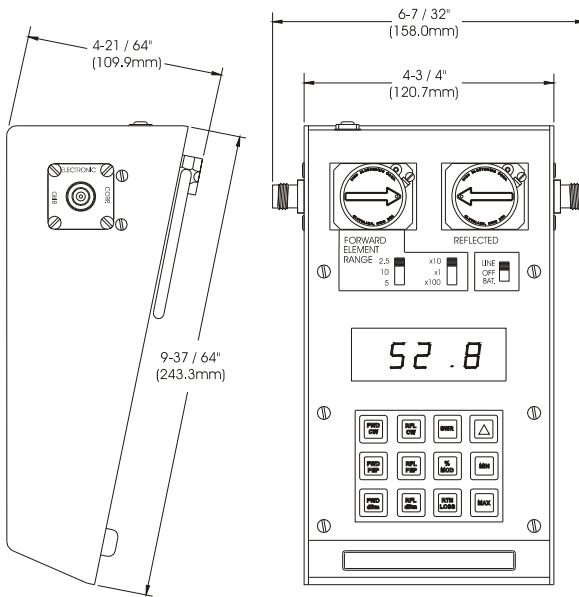

Description of Operation

Figure 2 is a block diagram of the major functional parts of the Model 4391A RF Wattmeter. The Microcomputer integrated circuit shown, controls all the other portions of the instrument, which fall into two major groups.

Figure 2 Circuit Block Diagram

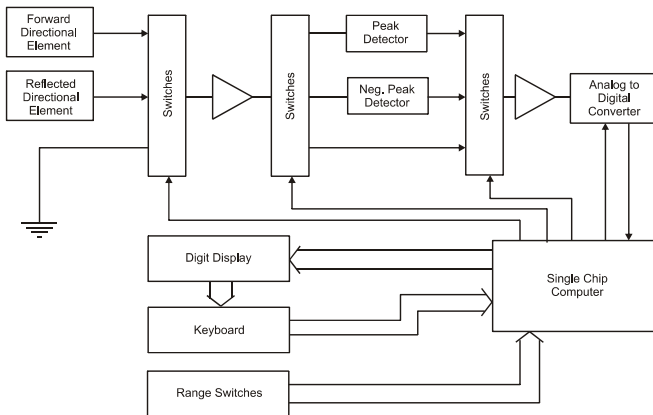

Keyboard, Range Switches, and Display Group

The keyboard and range switches serve only to pass information to the computer. The display, of course, returns information from the computer to the operator. The display, which is comprised of four seven-segment LED digits, is strobed digit by digit left to right at a rate of approximately one digit per millisecond. This serves to conserve battery power and drive circuitry while providing scanning for the columns of the keyboard. Each time a digit is strobed, the corresponding column of the keyboard is read and if a key is pressed, the computer puts the code for that key into a memory cell. The nine mode keys select which parameter is to be measured. The three modifier keys simply modify the way in which the result is displayed. The range selector switches identify to the computer the nominal full scale values of the elements used. They have no effect on input sensitivity, which is determined by the elements.

Elements, Analog Circuitry, and A/D Converter

These components are controlled by the computer. The Plug-in Elements in the line section provide low level positive voltages related to the instantaneous value of power (see Figure 3). The first group of solid state switches selects the forward element, the reflected element, or ground as the input to the preamplifier which boosts these signals to 0.1 to 2.0 volt range. The remaining switches shown as two groups direct the output of the preamp to the analog-to-digital converter either directly or through a peak or negative peak detector. The analog-to-digital converter converts the voltage to a 15 digit binary number.

Each reading output by the display is derived from up to three voltage readings using the circuitry described above. Once these voltages are measured, all remaining operations are performed within the computer chip as follows:

The voltages are corrected for error due to dc drift in the analog circuitry. Each voltage is converted to square root of power using stored data tables. These values are then combined mathematically to arrive at the final result in binary. This is used to update the registers containing the last value, the maximum value, or the minimum value as required. Finally, the result is converted to a decimal number and placed into a register from which the display driving routine operates.

Figure 3 Plug-In Element Schematic Diagram

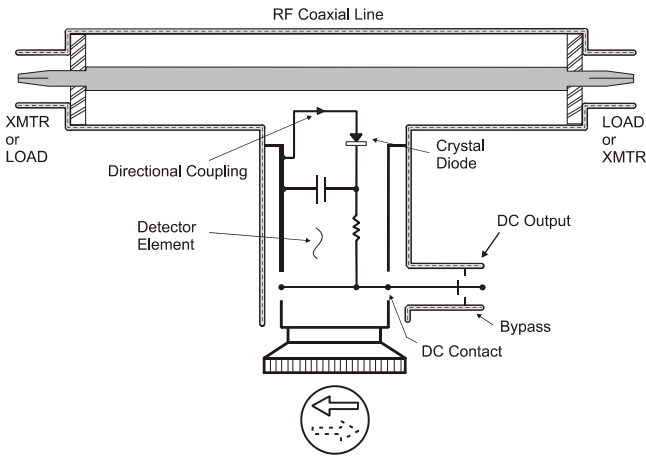

The coupling circuit that samples the travelling waves is in the Plug-in Element. The circuitry of the element and its relationship to the other components of the Thruline Watt-meter are illustrated in the schematic diagram. Energy will be produced in the coupling circuit of the element by both mutual inductance and capacitance from the travelling RF waves of the line section. The inductive currents will flow according to the direction of the travelling waves producing them. The capacitive portion of these currents is independent of the direction of the travelling waves. Therefore, assuming that the Plug-in Element remains station-

ary, the coupling currents produced from the waves of one direction will add in phase, and those produced from waves of the opposite direction will accordingly subtract in phase. The additive or “arrow” direction is assigned to the forward wave.

The electrical values of the element circuits are carefully balanced and designed so that current from the reverse wave will cancel the other almost completely. The result is directivity always higher than 25 dB, which means that the element is highly insensitive (nulled) to the REVERSE direction wave. Being highly directional, the ThruLine element is sensitive (at one setting) only to one of the traveling waves that produce standing waves by interference. ThruLine Wattmeter measurements are, therefore, independent of position along standing waves.

Figure 4 Readings with Various Envelopes

Transmission Type and Scope Pattern	Frequency Spectrum (C: Carrier)	PEVrms (arbitrary)	PEP = $PEV \sqrt{2} / Z_0$ rms	Average (Heating) Power	4391 Series			Model 43
					CW Mode	PEP Mode	%MOD Mode	
CW 		$\frac{100}{\sqrt{2}} \text{ V}$	100W	100W	100W	100W	0%	100W
AM 100% Mod. 		$\frac{200}{\sqrt{2}} \text{ V}$	400W	150W	100W	400W	100%	100W
AM 73% Mod. 		$\frac{173}{\sqrt{2}} \text{ V}$	300W	127W	100W	300W	73%	100W
SSB 1 tone 		$\frac{100}{\sqrt{2}} \text{ V}$	100W	100W	100W	100W	0%	100W
SSB 2 Tone 		$\frac{100}{\sqrt{2}} \text{ V}$	100W	50W	100W	25W	100%	40.5W
TV Black Level 		$\frac{100}{\sqrt{2}} \text{ V}$	100W	60W	100W	-	-	9.6W
Pulse 		$\frac{100}{\sqrt{2}} \text{ V}$	100W	0 W	100W	-	100%	-

$Z_0 = 50 \text{ ohms}$
 PEV : Peak Envelope Voltage. Carrier (or suppressed carrier) PEV was arbitrarily chosen at 100 volts in all examples. $PEV_{rms} = PEV / \sqrt{2}$.

The Model 4391A RF Power Analyst is completely portable and very suitable for field or laboratory use. Its power is derived from rechargeable nickel metal hydride batteries inside the unit or from an AC outlet via the power cord supplied with the device.

The batteries are shipped in a low charge state. It is, therefore, recommended that you charge the instrument for 16 hours before using it for continuous operation.

Note: *Battery charging at temperatures greater than 46° C (115° F) can result in reduced operational time.*

CAUTION

Long-term storage of this instrument can affect battery performance and reduce battery life. Do not store the instrument for long periods of time without recharging the batteries (refer to page 18). Failure to comply may result in reduced battery charge and shortened battery life.

Operating on AC Power

For AC power operation, the Model 4391A is simply connected to an AC receptacle using the line cord provided. The correct AC voltage is selected via a rear panel switch (Figure 5). The meter may be operated in this manner with the batteries removed if desired.

CAUTION

Always be certain the 115/230 voltage selector is set to the proper voltage before AC power is applied.

Figure 5 Rear Panel

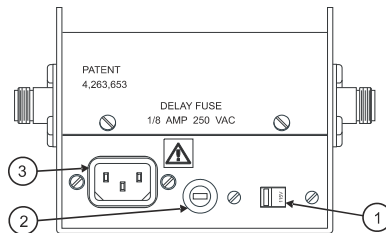

Item No.	Description
1	AC input voltage selector switch
2	Fuse holder
3	AC power cable connector

Connections

The Model 4391A contains a short section of rigid 50 ohm coaxial air dielectric transmission line. To make measurements relating to the travelling waves in a coaxial line, that line must be disconnected at some convenient point to permit the Model 4391A air line to be inserted.

Although the Model 4391A is normally supplied with two Female N-type connectors, a variety of easily interchangeable connectors are available to facilitate connecting to the user's system.

Once the Model 4391A is installed in the coaxial line, a Plug-in Element or a pair of Plug-in Elements must be selected which correspond to the frequency and power levels to be measured.

Note: *The instrument is shipped with dust plugs installed in the element sockets. Remove the dust plugs to insert elements.*

In order to take full advantage of the Model 4391A's capabilities, two elements in a 10:1 ratio of power range should be used. If only one element is used, the other socket should be filled with a dust plug or a higher power element. Also, for greatest accuracy, the element(s) should be chosen having the lowest possible power range that will not result in over-ranging. Table 1 lists elements required for each mode of operation.

Table 1 Plug-In Elements Required

Mode	Forward	Reflected
FWD CW	3	
RFL CW		3
SWR	3	3 *
FWD PEP	3	
RFL PEP		3
% MOD	3	
FWD dBm	3	
RFL dBm		3
RTN Loss	3	3 *

*. The reflected element must have a nominal power range one tenth that of the forward element.

The higher power element is placed in the socket marked "FORWARD" and its arrow pointed in the direction of forward power flow (toward antenna or load). The lower power element is placed in the socket marked "REFLECTED" and is normally pointed in the direction opposite to forward power flow. The elements are clamped in place by the hold-down catches on the face of the line section. These catches must be used to avoid error due to the element not contacting the bottom or seating plate of the socket. With the element(s) in place, set the range switches to correspond with the nominal power range of the elements. For example, if the forward element is a 5 watt element, the switches are set at 5 and x1. For a 250 watt element they are set at 2.5 and x100. Sometimes it is necessary to use milliwatts or kilowatts as the unit of measure. In other words, 1 watt becomes 10 x 100 milliwatts and 2500 watts becomes 2.5 x 1 kilowatts.

Operating Modes

The Model 4391A has nine modes of operation which are selected by pressing the mode keys momentarily. In addition, each mode has three output options selected by pressing the modifier keys. Detailed descriptions of the modes and output options follow.

Reading Forward CW Power

For this measurement only a forward element is needed. Install the meter and element according to the preceding paragraphs and move the power switch to LINE or BAT depending on the power source desired. When powered up, the Model 4391A always goes into the forward CW power mode. If the unit is already operating, the forward CW power mode is selected by pressing the FWD CW key momentarily. If the applied power exceeds 120 percent of the range, two right-facing arrow heads (i.e., “greater-than” symbols) will be displayed. The operation of this error message does not depend on the correct setting of the range switches by the operator, nor will the meter or its elements be damaged if the switches are incorrectly set.

CAUTION

Never apply RF power to the Model 4391A Wattmeter unless both line section sockets are filled with either an element or a dust plug. If an element is used it is advisable to place the element with the arrow at a 90° angle to the coaxial line.

CAUTION

Always disconnect AC power before opening the Model 4391A enclosure. Removal of at least one battery cell is also recommended when servicing the instrument.

Figure 6 Forward Power (CW)

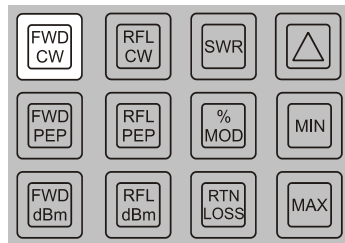

The Model 4391A arrives at values of CW power by a method quite different from analog meters such as the Model 43, also manufactured by Bird Electronic. While the two instruments will agree when the measured wave is of constant amplitude, AM or SSB waves will result in different indications (in the CW mode). This is because the analog instrument uses the inertia of the microammeter to “time-average” the varying signal coming from the element, whereas the Model 4391A uses peak and negative peak detector circuits to measure peak and minimum square root of power and combines them using the equation:

$$\text{CW POWER} = \left(\frac{\sqrt{\text{Peak Power}} + \sqrt{\text{Minimum Power}}}{2} \right)^2$$

With this technique, operation of CW mode is predictable regardless of envelope shape (see Figure 4).

Reading Reflected CW Power

Operation of the reflected CW power mode is identical to that for forward CW power described above with two exceptions: the readings are taken from the element in the socket marked “REFLECTED” and the range of the element is assumed to be 1/10 the range indicated by the range switches.

Figure 7 Reflected Power (CW)

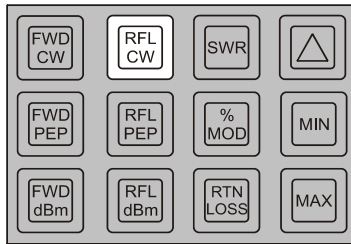

Reading SWR

Two elements with a 10 to 1 power range ratio are required for this mode. Press the SWR key momentarily. If average forward power is between 10% and 120% of the scale and the average reflected power is less than 120% of the reflected element range, SWR will be displayed. If any of the above conditions are not met, an error message will be displayed. Two arrows pointing to the right — or “greater-than” symbols — indicate over-range, while two left-pointing arrows — or “less-than” symbols — indicate under-range or too little power. Refer to Table 2.

Figure 8 Standing Wave Ratio (SWR)

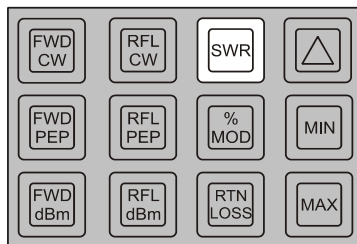

Table 2 Voltage Standing Wave Ratio (VSWR)

VSWR	Return Loss (dB)	Reflected Power %	VSWR	Return Loss (dB)	Reflected Power %
1.01	46.1	0.00	1.45	14.7	3.37
1.02	40.1	0.01	1.50	14.0	4.00
1.03	36.6	0.02	1.75	11.3	7.44
1.04	34.2	0.04	2.00	9.50	11.11
1.05	32.3	0.06	2.25	8.30	14.79
1.06	30.7	0.08	2.50	7.40	18.37
1.07	29.4	0.11	2.75	6.60	21.78
1.08	28.3	0.15	3.00	6.00	25.00
1.09	27.3	0.19	3.25	5.50	28.03
1.10	26.4	0.23	3.50	5.10	30.86
1.15	23.1	0.49	3.75	4.70	33.52
1.20	20.8	0.83	4.00	4.40	36.00
1.25	19.1	1.23	4.25	4.20	38.32
1.30	17.7	1.70	4.50	3.90	40.50
1.35	16.5	2.22	4.75	3.70	42.53
1.40	15.6	2.78	5.00	3.50	44.44

Measuring Peak Envelope Power

PEP power measurements are made in the same manner as CW power readings described above, except that the FWD PEP and RFL PEP buttons are pressed and the readings are displayed directly as peak power.

Note: *The accuracy of measurements made with modulation having a frequency, duty cycle, pulse width, or repetition rate outside the instrument range cannot be assured in any mode of operation.*

Figure 9 Peak Envelope Power (PEP)

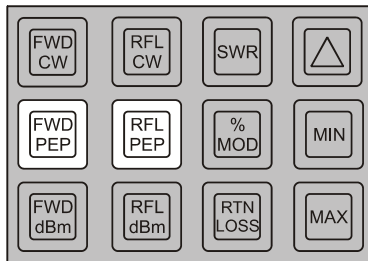

Measuring Amplitude Modulation

Only a forward element is required for this mode. Point the element in the direction of forward power and press % MOD. Modulation is displayed directly in percent, provided the average signal is above 10% and the PEP of the signal is below 400% of the element's nominal full scale. For specified accuracy, the average CW power levels must be greater than one-third of full scale. Modulation is calculated as follows:

$$\text{MODULATION} = \frac{\sqrt{\text{Peak Power}} - \sqrt{\text{Minimum Power}}}{\sqrt{\text{Peak Power}} + \sqrt{\text{Minimum Power}}} \times 100$$

and is therefore limited to the range of 0 to 99.9 percent. Over-modulation will be indicated as 99.9 percent. Refer to Table 3.

Table 3 Amplitude Modulation

Peak / CW Power	% Modulation	Peak / CW Power	% Modulation
1.00	0	2.40	55
1.10	5	2.56	60
1.21	10	2.72	65
1.32	15	2.89	70
1.44	20	3.06	75
1.56	25	3.24	80
1.69	30	3.42	85
1.82	35	3.61	90
1.96	40	3.80	95
2.10	45	4.00	100
2.25	50		

Because of the threshold of the RF diode, a modulated signal which has a minimum power level below 0.3 percent of full scale will result in high modulation reading with uncertain accuracy.

Figure 10 Amplitude Modulation (%)

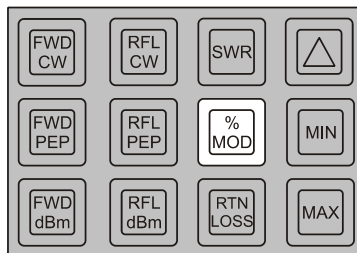

Measuring Power in dBm

Operation of the forward and reflected dBm modes is identical to the forward and reflected CW power modes, except that the resulting reading is converted to dB above 1 milliwatt before it is displayed. It should be noted that in doing this conversion, the range set on the slide switches is assumed to be watts rather than kilowatts or milliwatts. If it is not, 30.0 must be added to all dBm readings when the range is in kilowatts, or subtracted from all readings when it is in milliwatts. An error message is displayed if CW power is more than 24 dB below, or peak power is more than 6 dB above the nominal element range. Refer to Table 4.

Figure 11 CW Power in dBm

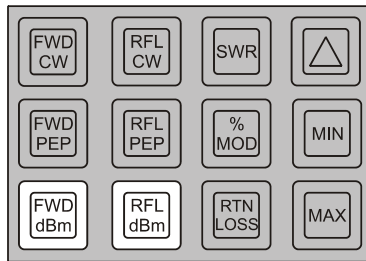

Table 4 Watts/dBm Equivalents

Power	dBm	Power	dBm
1 milliwatt	0	4 watts	36
10 milliwatts	10	10 watts	40
100 milliwatts	20	20 watts	43
1 watt	30	40 watts	46
2 watts	33	100 watts	50

Measuring Return Loss

The measurement of return loss is the same as that of SWR except that the result is displayed in dB. In other words a reading of 21.65 indicates that reflected power is 21.6 dB down from forward power.

Figure 12 Return Loss, Insertion Loss, or Attenuation

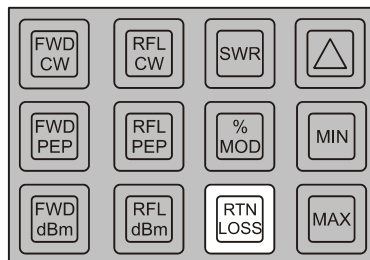

Insertion Loss or Attenuation

Attenuation or insertion loss can be measured directly using an external single port line section (P/N 4230-006-1), a dc feed-in adapter (P/N 4381-050), and a dc cable (P/N 3170-058-6). The Model 4391A is inserted at the source end of the device being measured. The second line section is inserted at the load end and its dc output is routed by the dc cable to the adapter inserted in the REFLECTED socket of the Model 4391A. Both elements are in this case pointed in the direction of forward power flow. If the two elements do not have a ten to one ratio, a correction factor must be added to or subtracted from the “return loss” reading see Table 5, depending on the ratio of the elements.

Table 5 Correction Factors

Ratio of Elements	Added dB	Ratio of Elements	Added dB
1:1	-10	100:1	10
2:1	-7	200:1	13
2.5:1	-6	250:1	14
4:1	-4	400:1	16
5:1	-3	500:1	17
10:1	0	1000:1	20
20:1	3	2000:1	23
25:1	4	2500:1	24
40:1	6	4000:1	26
50:1	7	5000:1	27

Monitoring Maximum and Minimum Readings

While operating in any of the modes described, the Model 4391A will continuously keep track of the highest and lowest reading obtained. This action begins after ten reading cycles to allow time for the peak detectors to settle from the previous mode. To recall the maximum or minimum reading, depress and hold the MAX or MIN key. When these keys are released, the meter goes back to displaying the current value of the parameter being measured. Recalling max or min does not stop the meter from continuing to monitor the current value and updating the minimum and maximum registers. To clear the minimum and maximum register, the mode key must be pressed again or a new mode selected. For example, if CW power deviations are monitored, the Model 4391A is installed as described at the beginning of this section and turned on, then the power source is turned on and allowed to stabilize. Once the system has stabilized, press FWD CW to clear the MAX and MIN registers. At any time during test the MAX and MIN keys can be used to recall the maximum and minimum values without affecting the test. However, pressing the FWD CW key or changing modes will clear the registers.

Figure 13 Maximum or Minimum Readings

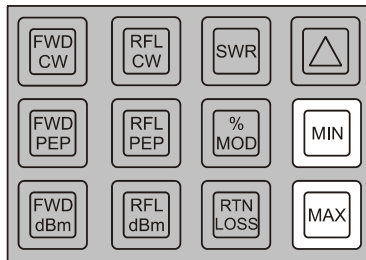

Using the Peaking Aid

The peaking aid is useful for making adjustments to optimize any of the parameters which the Model 4391A measures. After the mode is selected, press the delta (Δ) key momentarily. This blanks the least significant digit of the display, and replaces it with a right-facing arrow head if the measured quantity is increasing or a left-facing arrow head if it is decreasing. If there is no change, the digit is left blank. To find a peak, begin making the adjustment in whichever direction produces a right-facing arrow and continue slowly in that direction until the arrow head turns around. At this point the peak has been reached. To check to make sure the peak has not been passed, press the MAX key to read the highest value read and release it to read the current value. The two should be the same. Desired minimum levels (e.g. of reflected power or of SWR) are found in a similar manner.

Figure 14 Peaking Aid (D)

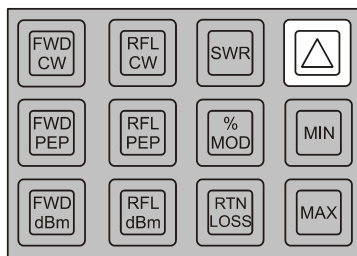

Battery Care

With average use, the nickel metal hydride batteries in the 4391A will power the unit for 12 hours before needing recharged. The 4391A will maintain rated accuracy until all the decimal points light, indicating that recharging is required. To recharge, connect AC power to the unit. To fully charge the batteries requires approximately 16 hours. To prolong the life of the batteries, it is recommended that you periodically allow the batteries to discharge until the decimal points light before recharging. If the batteries lose the ability to hold a charge they should be replaced. See Chapter 5, Maintenance, page 17 for important precautions regarding static electricity when opening the housing.

WARNING

Use only Nickel Metal Hydride (NiMH) batteries that have a minimum capacity of 4500 milliampere hours (mAh). Do not install batteries that are not Nickel Metal Hydride. Do not install NiMH batteries that have less than 4500 mAh capacity. Failure to comply may result in damage to the batteries, damage to the instrument, and injury to personnel from battery chemicals.

CAUTION

Long-term storage of this instrument can affect battery performance and reduce battery life. Do not store the instrument for long periods of time without recharging the batteries (refer to page 18). Failure to comply may result in reduced battery charge and shortened battery life.

The 4391A RF Power Analyst was designed and built to provide many years of trouble free service. This section provides the information needed to prevent and correct equipment failure.

Preventive Maintenance

To avoid unnecessary damage, always observe the following cautions:

CAUTION

The RF Power Analyst is a rugged and portable instrument intended for field use. However, it should not be unnecessarily exposed to extreme environmental conditions.

CAUTION

When not in use, store the RF Power Analyst with the LINE/OFF/BATT switch is in the off position.

CAUTION

Charge the batteries for 16 hours prior to extended use of the RF Power Analyst. Refer to "Battery Care" on page 15.

Cleaning and Inspection

Perform a periodic inspection to ensure that the RF power analyst is always operational.

Note: *Any damage noticed during inspection should be listed and repaired before use.*

- Visually inspect the equipment for loose or damaged parts.
- Wipe dust and dirt from the front panel and lower housing.
- Remove dirt with mild detergent and a soft cloth.

WARNING

Use dry cleaning solvents in a well ventilated area. Avoid excessive inhalation of solvent fumes, since they can be toxic in heavy concentrations. Always wear eye protection and avoid skin contact with the solvent.

- Clean the inside of the line section bores using cotton swab stick dampened with alcohol.

- Inspect the RF connectors for any sign of wear or damage. Replace if necessary.
- Clean the connectors with alcohol or any acceptable dry cleaning fluid.

Long-term Storage

Do not store the instrument for long periods of time without recharging the batteries. When the instrument is stored for long periods of time without use, the batteries will lose their charge and also lose the ability to reach full charge when put into service. To restore the battery charge, perform a full charge for 16 hours. If the batteries are not fully charged after 16 hours, completely discharge the batteries then perform a full charge again. If necessary, repeat this discharge and charge cycle up to three times. If the batteries do not remain charged after three discharge-charge cycles, replace the batteries.

WARNING

Use only Nickel Metal Hydride (NiMH) batteries that have a minimum capacity of 4500 milliampere hours (mAh). Do not install batteries that are not Nickel Metal Hydride. Do not install NiMH batteries that have less than 4500 mAh capacity. Failure to comply may result in damage to the batteries, damage to the instrument, and injury to personnel from battery chemicals.

Calibration

The RF Power Analyst should be calibrated once each year or after any repair.

Required Equipment

Refer to Table 7 for test equipment needed to calibrate the RF Power Analyst.

Table 6 Required Calibration Equipment

Equipment	Recommended Model
Calibrator/Source	Keithly Model 263 or equivalent
Cable Assembly (1 Required)	BNC to BNC (1 meter long)
DC Feed-in Element (1 required)	Bird Electronic 4381-050

Initial Setup

Note: *On a clean flat workspace perform the following setup procedure:*

1. Remove the front panel. Refer to "Front Panel Removal" on page 23.
2. Insert a DC feed-in adapter into the FWD element of the socket.
3. Insert a metal dust plug (supplied with the instrument) into the RFL element socket.
4. Connect a BNC to BNC cable assembly from the output of calibrator/source to the DC feed-in adapter.
5. Set the RF Power Analyst range switches to the 10 and x100 positions.
6. Connect AC power and place the LINE/OFF/BATT switch to the LINE setting.
7. Switch on the Calibrator/Source.
8. Allow it to warm up for at least one hour.
9. Set the Calibrator/Source to output 30 ± 0.05 microamps.
10. Adjust potentiometer, R25 (Figure 15 on page 19), until the RF Power Analyst Displays 1000 ± 5 .

Figure 15 Calibration Potentiometer

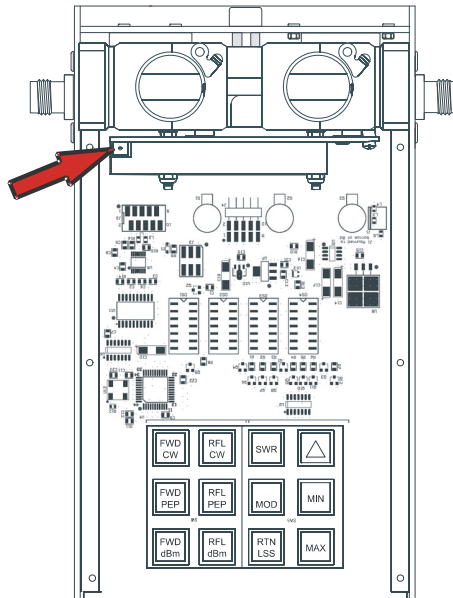

Element Wiper Contact Adjustment

CAUTION

If the element cannot be fully inserted into the socket, do not force it. You might damage the element.

CAUTION

Be careful not to bend the spring out so far that it interferes with insertion of the elements.

Note: Continuous insertion or rotation of the element might cause a slight change in the position of the contact spring in the element socket. If the contact spring changes position, you might experience erratic power readings.

1. Place the flat side of a small flat head screwdriver behind the contact bar as indicated.
2. Bend the contact bar so that the contact rests in the center of the slot adjacent to the element socket (Figure 16).

Figure 16 Adjust Element Contact Up and Down

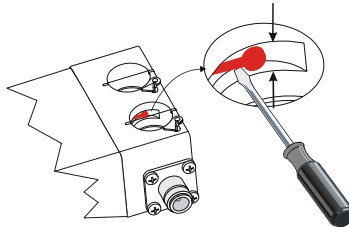

3. Bend the contact slightly toward the center of the element socket bore.

Note: Ensure the profile of the element contact is visible when viewing the element socket from the top of the socket bore (Figure 17).

Figure 17 Adjust Element Contact In and Out

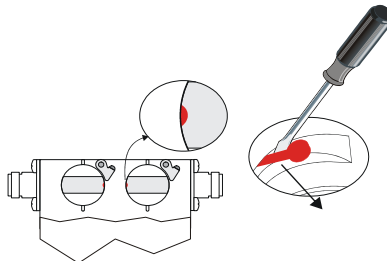

Note: If the contact is accidentally moved too far into the element bore, the element will not slide into the socket.

4. Move the contact back into the recessed area and repeat the process.

Troubleshooting

General

The troubleshooting instructions are intended to aid in fault isolation. This is accomplished through the use of a troubleshooting table.

First, locate the symptom(s) in the problem column of Table 7. In some cases the same fault can have more than one symptom and more than one possible remedy. Compare the possible causes until you arrive at a suspected fault. Once a fault has been isolated, repair or replace the defective components.

Note: *Always recalibrate the RF Power Analyst after repairing the fault.*

Table 7 Trouble-shooting

PROBLEM	POSSIBLE CAUSE	REMEDY
Inaccurate power readings	RF Power Analyst uncalibrated	Recalibrate.
	Defective Plug-in Elements	Replace defective elements.
	Intermittent connection at the element wiper	Adjust the element wiper contact.
	Loose hold down catch	Readjust catch to hold element securely in place.
	Worn line section	Replace line section.
	Defect on Data Acquisition PC board assembly	Replace the PC board assembly (attached to line section).
High standing waves	Dirty Connectors	Clean the connectors.
	Worn or damaged connectors	Replace the connectors
	Foreign objects in line section	Remove object from the line section.
Short battery life	115/230V switch in wrong position	Set 115/230V switch to correct position.
	Damaged/worn batteries	Replace the batteries.
Will not operate from AC line	115/230V switch in wrong position	Set 115/230V switch to correct position.
	Blown fuse	Replace blown fuse.
	Defective line cord	Repair or replace.

PROBLEM	POSSIBLE CAUSE	REMEDY
Display indicates "0" Power	Element wiper not contacting the element	Readjust the element wiper to make good contact.
	Defective Plug-in Element	Replace Plug-In Element.
	Defect on Data Acquisition PC board assembly	Replace the PC board assembly (attached to line section).
One segment of a display does not light	Defective Display	Replace the display.
All decimal points stay lit	Low charge on the batteries	Recharge the batteries.
	Defective circuit component	Replace the Main circuit board assembly.
Same segment on all displays doesn't light	Defective circuit component	Replace the Main circuit board assembly.
One or more keys do not function	Defect on Main PC board	Replace the Main circuit board assembly.

Disassembly

WARNING

Be sure that the power cable is unplugged before opening the wattmeter case. The power supply capacitor, C1, can retain a dangerous charge that must be removed before touching. Always have another person standing by who is trained in electric shock first aid.

CAUTION

This instrument contains static sensitive electronic components. Before opening or servicing the unit, make sure that you understand and practice electrostatic discharge component handling. Failure to comply may result in permanent damage to sensitive components.

Front Panel Removal

1. Disconnect AC power from the instrument.
2. Remove the six screws that secure the front panel to the Main PCB supports (Figure 18 on page 23, item 1).
3. Remove the two screws and lock washers that secure the front panel at the bottom of the housing (item 2).
4. Remove the two screws and lock washers that secure the front panel at the back of the housing (item 3).
5. Lift the front panel from the housing.

Note: Be careful to clear the line section blocks.

6. Remove pads from the three toggle switches.

Figure 18 Removing Front Panel

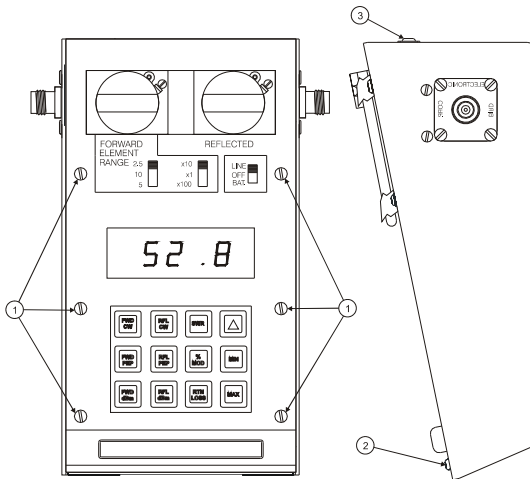

Main Printed Circuit (PC) Board Removal

1. Remove the front panel. Refer to "Front Panel Removal" on page 23.
2. Disconnect cable assembly at header (J4) (Figure 19 on page 24, item 1).
3. Remove the six screws and washers that secure the circuit board supports to the housing (item 2).
4. Lift the Main PC board.

Note: Locate the cable coming from the power supply assembly.

5. Disconnect the cable assembly at header (J1). (Figure 19 on page 24, item 3).

Figure 19 Removing Main PCB

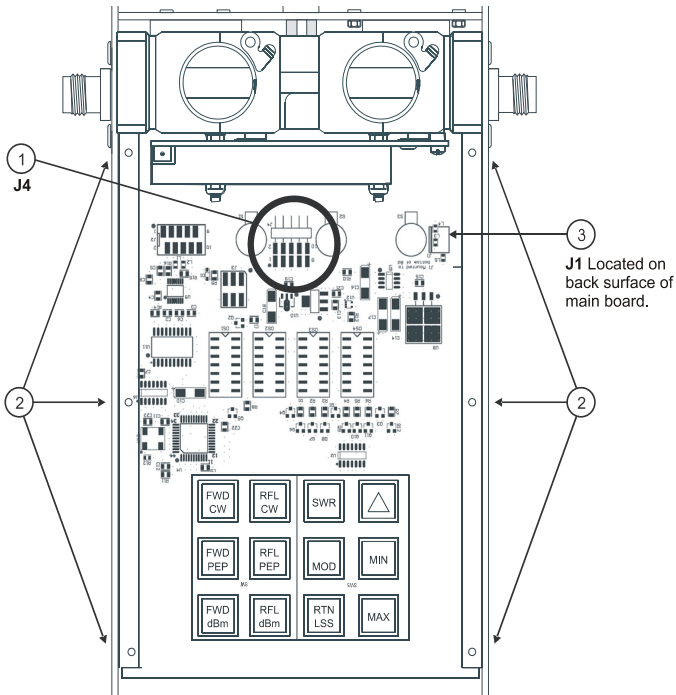

QC Connectors Removal

1. Remove the eight screws (four on each connector) that secure the connectors to the housing (Figure 20, item 1).
2. Remove the two “QC” connectors (item 2) by pulling them away from the line section assembly.

Line Section Removal

1. Remove the QC connectors (page 24).
2. Remove the four screws and lock washers that secure line section assembly to the housing (item 3).
3. Spread apart the sides of the lower housing assembly far enough to allow the line section assembly to be removed.

Note: Use minimum pressure when performing this step.

Figure 20 Removing QC Connectors and Line Section

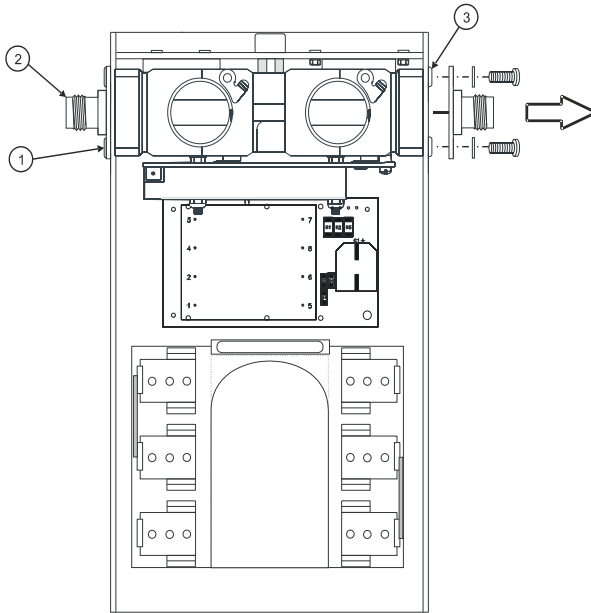

CAUTION

This instrument contains static sensitive electronic components. Before opening or servicing the unit, make sure that you understand and practice electrostatic discharge component handling. Failure to comply may result in permanent damage to sensitive components.

4. Remove the two hex nuts (Figure 21, item 5) that secure the PCB.
5. Remove the cover (item 6) and spacers (item 7).
6. Disconnect the ribbon cable assembly from the PC board header (P1).
7. Remove the two screws (item 4) that secure the PCB to the line section then pull the PC board assembly (item 3) away from the line section subassembly.
8. Remove the spacers (item 2).
9. Remove keying beads (item 1) from the element wiper contacts on the PC board assembly.

Figure 21 Removing Line Section PCB

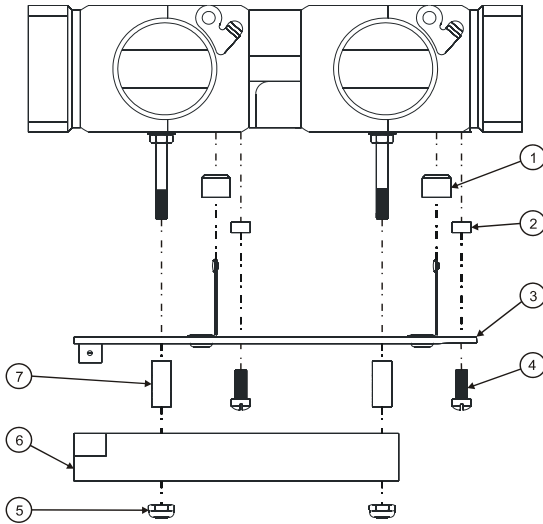

Battery Replacement

1. Remove the front panel (refer to "Front Panel Removal" on page 23) .
2. Remove the four screws and lock washers (Figure 22, item 1) that secure the Main PCB.
3. Loosen, but do not remove the remaining two screws that secure the Main PCB (item 2).
4. Tilt the Main PC board assembly up to expose the batteries then tighten the two screws to secure the PCB.

Figure 22 Tilt Main PCB to Expose Batteries

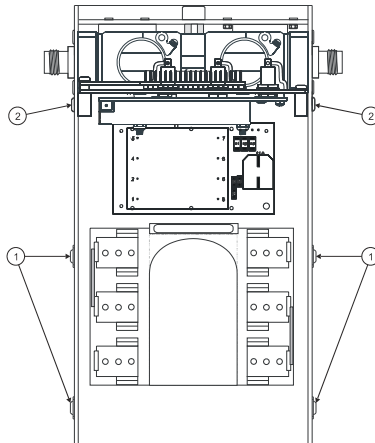

5. Unfasten the velcro strap and remove it from the D-ring. (Figure 23).

Note: *The polarity orientation of the batteries must remain consistent.*

6. Remove the three battery tubes from the battery clips then remove two batteries from each tube.
7. Install new batteries into the tubes then secure the tubes in the battery clips.

Note: *Be sure to observe proper polarity.*

8. Lower and secure the Main PC board assembly
9. Replace and secure the front cover.
10. Charge the batteries for 16 hours before using the instrument.

Figure 23 Battery Replacement

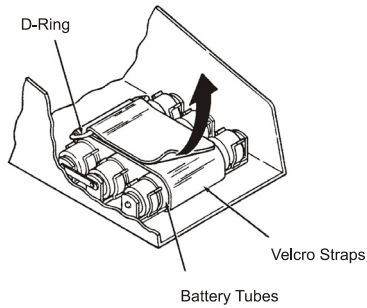

Parts List

This section contains an illustrated list of all authorized replacement parts for the 4391A RF power Analyst. Parts are grouped into major assemblies and sub-assemblies.

Figure 24 Parts Drawing

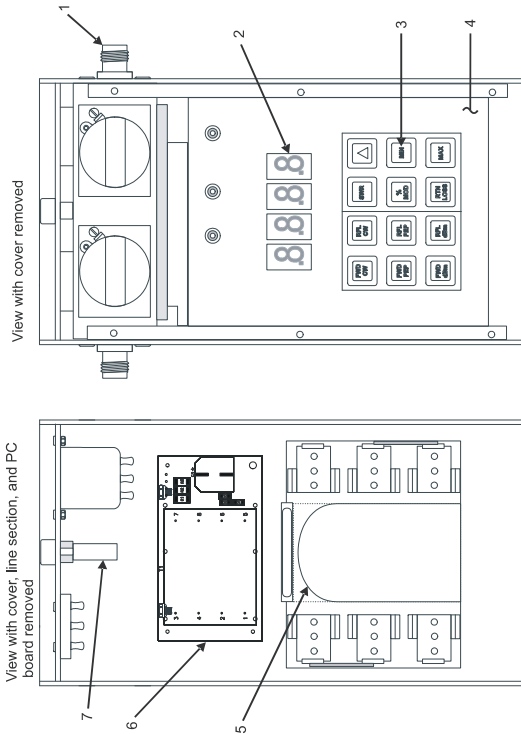

Item No.	Description	Part No.	Qty
Figure 24			
1	Connector, QC F-N	4240-062	2
2	LED display, (DS1 - DS4)	5-1337	4
3	Keyboard legend	4386-012	1
4	PC board, Main, assembly	4391C007	1
5	Velcro strap	5-1958	1
6	PC board assy (includes rectifier circuit)	4391B041	1
7	Fuse, Slo-Blo, IEC 1/8 amp	5A2257-7	1
N/S	Battery (rechargeable) "C" cell	5A1230	6
N/S	Dust plug	3610-031	2
N/S	Cable, power cord, 115V / 230V	4421-055	1

N/S = not shown in figure

Figure 25 Line Section Assembly (S/N 1723 & below)

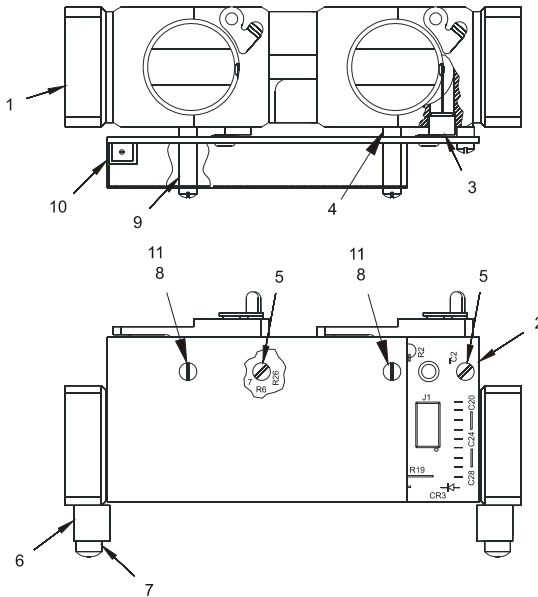

Item No.	Description		Part No.	Qty
Figure 25				
1	Line Section, Subassembly		4381-005	1
2	PC Board, Data Acquisition Assy		4391A006	1
3	Bead, Keying		4391-026	2
4	Spacer		4391-027	2
5	Screw, Machine, filister head, No. 4-40, 1/4 in. lg, sst		COML	2
6	Support		4381-029	2
7	Screw, Machine, filister head, No. 8-32, 1/2 in. lg, sst		COML	4
8	Screw, Machine, filister head, No. 4-40, 7/8 in. lg, sst		COML	2
9	Spacer		4391-035-1	2
10	Cover, PC Board		4391-034	1
11	Lock Washer, No. 4 internal sst		COML	2
N/A	Line Section Complete		4391-014	1

Figure 26 Line Section Assembly (S/N 1724 & above)

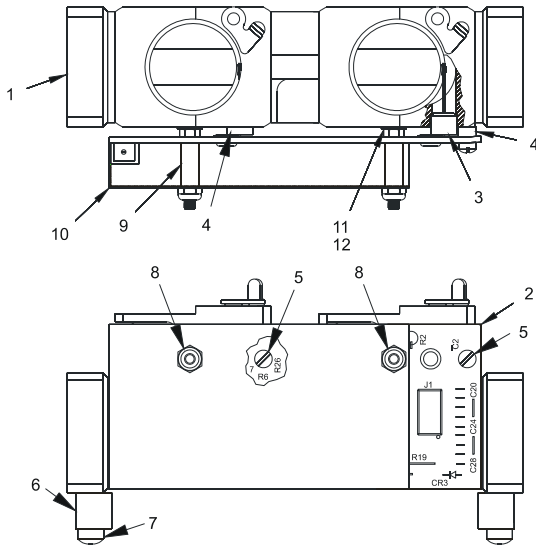

Part No.	Description	Part No.	Qty
Figure 26			
1	Line Section, Subassembly	4381-005	1
2	PC Board, Data Acquisition Assy	4391A006	1
3	Bead, Keying	4391-026	2
4	Spacer	4391-027	2
5	Screw, Machine, filister head, No. 4-40, 1/4 in. lg, sst	COML	2
6	Support	4381-029	2
7	Screw, Machine, filister head, No. 8-32, 1/2 in. lg, sst	COML	4
8	Hex Nut, with nylon insert, No. 4-40	1131-1013-00	2
9	Spacer	4391-035-1	2
10	Cover, PC Board	4391-034	1
11	Lock Washer, No. 4 internal sst	COML	2
12	Standoff, Threaded	4391-038	2

Customer Service

Any maintenance or service procedure beyond the scope of those in this chapter should be referred to a qualified service center.

If you need to return the unit for any reason, request an RMA through the Bird Technologies website (link shown below). All instruments returned must be shipped pre-paid and to the attention of the RMA number.

Bird Service Center

30303 Aurora Road
Cleveland (Solon), Ohio 44139-2794
Fax: (440) 248-5426
E-mail: bsc@bird-technologies.com

For the location of the Sales Office nearest you, visit our website at:

<http://www.bird-technologies.com>

Specifications

Measuring Medium	RF Transmission in 50 ohm lines
RF Power Range *	100 mW to 10 kW full scale using Bird Plug-in Elements. Accuracy not guaranteed with components not supplied by Bird
Usable Over-Range *	To 120% of scale on CW, PEP, SWR, and Return loss functions. To 400% of scale (PEP) on dBm and 0% modulation.
Frequency Range	450 kHz to 2.7 GHz
Sampling Range	2-3 readings per second
Settling Time	10 seconds (worst case) [†]
Accuracy	
Power Readings	
CW	±5% of full scale
PEP	±8% of full scale
SWR	±10% of reading
% Modulation	±5% [‡]
Return Loss	±0.3 dB to corresponding SWR value
Impedance	50 ohms
Insertion SWR	1.05 max to 1000 MHz
Pulse Parameters (square pulses)	
Pulse Width	0.8 μsec. min.**
Repetition Rate	25 pps min.
Duty Cycle	0.01% min.
RF Line Connections	
Standard	Bird Quick Change "QC" Female N
Optional	Any Standard AN "QC" type
Temperature Range	
Operating	10°C to 45°C (50°F to 113° F)
Storage	-20°C to 45°C (-4°F to 113° F)
Input Power Requirements	100-130 or 200-230 VAC (Switch Selectable) or 7.2 Vdc (internal battery)
Voltage	50-60 Hz
Frequency	6 Watts
Power	6-1.2 V NiMH C size (Rechargeable)
Batteries	12 hours approx. (reduced after high temperature charging)
Battery Life	
Weight	5-3/4 lb (2.6 kg)

- *. Frequency band and power range is determined by the Plug-in Elements selected. See Bird Catalog for availability. Some modes require two elements in a 10:1 power ratio.
- †. VSWR and return loss functions settle in less than 1 second.
- ‡. For CW power levels greater than one-third of full scale, accuracy of the percent modulation mode is 5% from 0 to 90% and +10% from 90 to 100%. Modulation frequency is 25 to 100,000 Hz; except for “A” and “B” elements: 25 to 20,000 Hz; and “H” elements: 25-10,000 Hz.
- **For “A” and “B” elements the minimum pulse width is 1.5 microseconds. For “H” elements the minimum pulse width is 15 microseconds.

LIMITED WARRANTY

All products manufactured by Seller are warranted to be free from defects in material and workmanship for a period of one (1) year, unless otherwise specified, from date of shipment and to conform to applicable specifications, drawings, blueprints and/or samples. Seller's sole obligation under these warranties shall be to issue credit, repair or replace any item or part thereof which is proved to be other than as warranted; no allowance shall be made for any labor charges of Buyer for replacement of parts, adjustment or repairs, or any other work, unless such charges are authorized in advance by Seller.

If Seller's products are claimed to be defective in material or workmanship or not to conform to specifications, drawings, blueprints and/or samples, Seller shall, upon prompt notice thereof, either examine the products where they are located or issue shipping instructions for return to Seller (transportation charges prepaid by Buyer). In the event any of our products are proved to be other than as warranted, transportation costs (cheapest way) to and from Seller's plant, will be borne by Seller and reimbursement or credit will be made for amounts so expended by Buyer. Every such claim for breach of these warranties shall be deemed to be waived by Buyer unless made in writing within ten (10) days from the date of discovery of the defect.

The above warranties shall not extend to any products or parts thereof which have been subjected to any misuse or neglect, damaged by accident, rendered defective by reason of improper installation or by the performance of repairs or alterations outside of our plant, and shall not apply to any goods or parts thereof furnished by Buyer or acquired from others at Buyer's request and/or to Buyer's specifications. Routine (regularly required) calibration is not covered under this limited warranty. In addition, Seller's warranties do not extend to the failure of tubes, transistors, fuses and batteries, or to other equipment and parts manufactured by others except to the extent of the original manufacturer's warranty to Seller.

The obligations under the foregoing warranties are limited to the precise terms thereof. These warranties provide exclusive remedies, expressly in lieu of all other remedies including claims for special or consequential damages. SELLER NEITHER MAKES NOR ASSUMES ANY OTHER WARRANTY WHATSOEVER, WHETHER EXPRESS, STATUTORY, OR IMPLIED, INCLUDING WARRANTIES OF MERCHANTABILITY AND FITNESS, AND NO PERSON IS AUTHORIZED TO ASSUME FOR SELLER ANY OBLIGATION OR LIABILITY NOT STRICTLY IN ACCORDANCE WITH THE FOREGOING.