

David Clark COMPANY INCORPORATED

360 Franklin Street, Box 15054, Worcester, MA 01615-0054
TEL.: (508) 751-5800 E-Mail: sales@DavidClark.com FAX: (508) 753-5827

PARTS LIST MODEL H9940

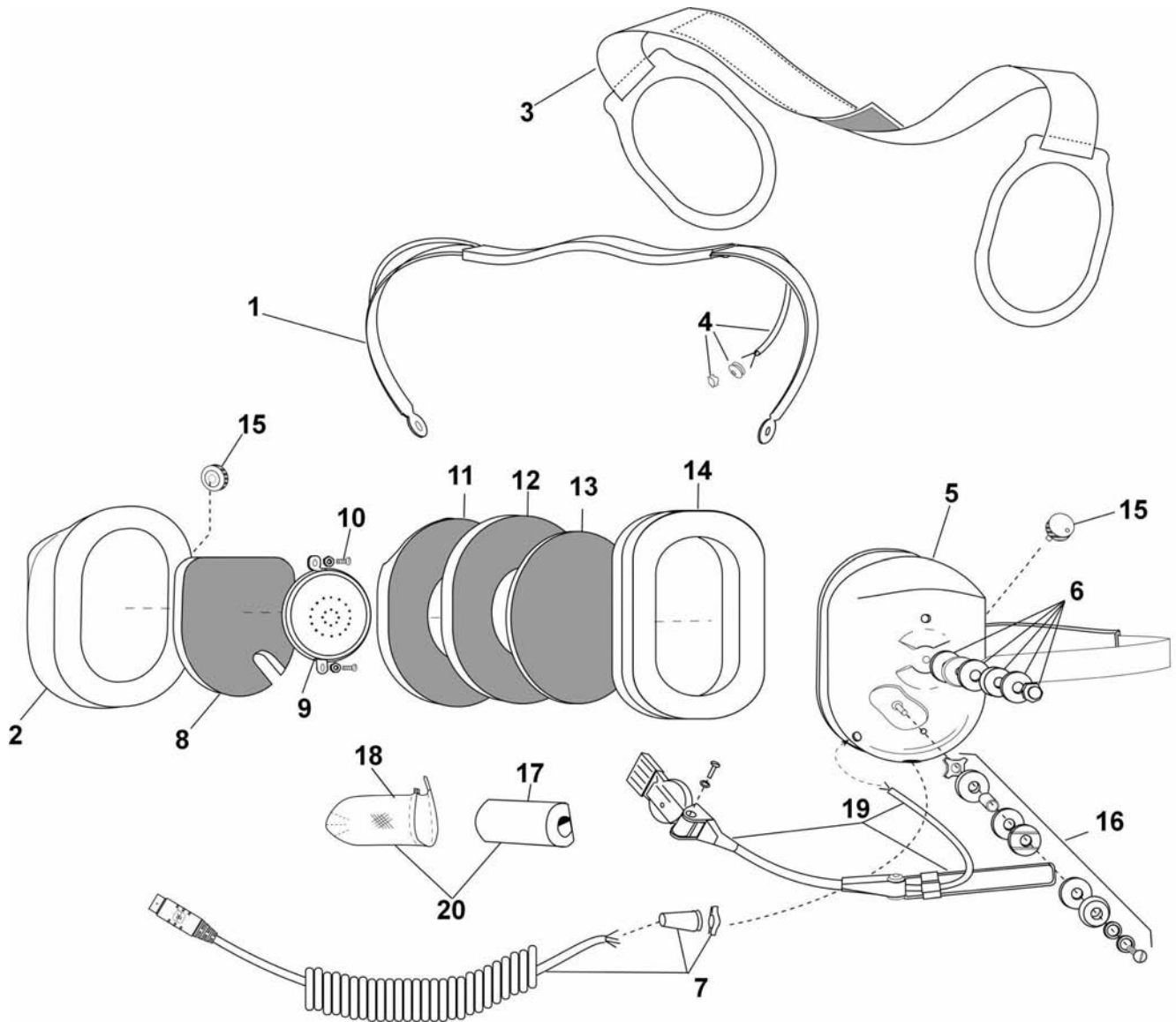

No.	Description	Part No.
1	Spring Assembly	40623G-50
2	Dome, Right	15522P-41
3	Support Assembly	10370G-03
4	Overhead Cord Kit	22607G-01
5	Dome, Left (mic side)	15522P-42
6	Nut and Washer Kit	12052G-04
7	Comm Cord Assy Kit	40599G-98
8	Dome Filter	11410P-02
9	Earphone Assembly	10376G-55
10	Screw (10/pk)	00023M-07

No.	Description	Part No.
11	Dome Filter	25629P-05
12	Dome Filter	14096P-05
13	Filter	14096P-09
14	Undercut Gel Earseal (pair)	40863G-02
15	Volume Control	09349P-57
16	Boom Guide Kit	12840G-18
17	Screen, Wind, Mic	14863P-01
18	Cover, Windscreen	18792G-02
19	Mic, M87 & Boom w/Cord	40910G-02
20	Kit, Mic Cover/Windscreen	40688G-94

ELECTRICAL SCHEMATIC MODEL H9940

