

**USER MANUAL**  
**Wireless Belt Station, non-VOX**  
**U9912-BSW**  
**(P/N: 40992G-02)**



## Cautions and Warnings

**READ AND SAVE THESE INSTRUCTIONS.** Follow the instructions in this installation manual. These instructions must be followed to avoid damage to this product and associated equipment. Product operation and reliability depends on proper usage.



**DO NOT INSTALL ANY DAVID CLARK COMPANY PRODUCT THAT APPEARS DAMAGED.** Upon unpacking your David Clark product, inspect the contents for shipping damage. If damage is apparent, immediately file a claim with the carrier and notify your David Clark product supplier.



**ELECTRICAL HAZARD** - Disconnect electrical power when making any internal adjustments or repairs. All repairs should be performed by a representative or authorized agent of the David Clark Company.



**STATIC HAZARD** - Static electricity can damage components. Therefore, be sure to ground yourself before opening or installing components.



**LI-POLYMER** - This product is used with Li-Polymer batteries. Do not incinerate, disassemble, short circuit, or expose the battery to high temperatures. Battery must be disposed of properly in accordance with local regulations.

## Overview

The U9912-BSW (40992G-02) Wireless Belt Station is a portable wireless communication device that when used in conjunction with a U9911-BSC (41033G-01) Controller Belt Station or one of the U9900-series gateways becomes part of a wireless intercom system. Up to five users are able to communicate with each other when using the U9911-BSC. Up to four users are able to communicate with each other and also with a two-way radio or other wired intercom system when using one of the U9900-series gateways. Only one gateway/controller is required per system. Up to four belt stations can be connected to one controller/gateway.

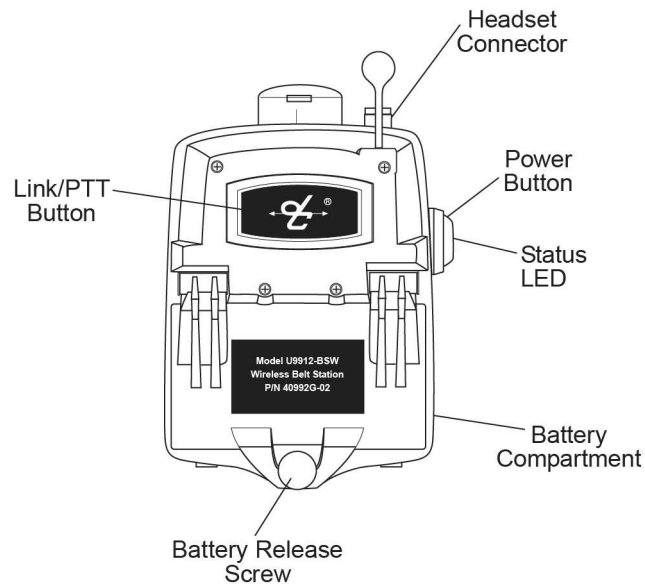

**Figure 1: Overview of Belt Station**

The U9912-BSW non-VOX Wireless Belt Station is commonly used where extremely high and varying noise levels become challenging to a VOX belt station's settings, resulting in unwanted noise being present in a VOX belt station user's headset and causing him/her to frequently adjust the VOX setting. VOX belt stations may be desired in more stable and less extreme noise environments.

## Linking

Before a belt station and a controller/gateway can be connected, they must first be **Linked**. As a security measure, the **close-link** feature requires devices to be in proximity of about 1 to 3 ft (0.3 to 0.9m) in order to successfully link. This ensures that the units are not inadvertently linked with other units on the premises.

Linking procedure:

1. Ensure units are within 1 to 3 ft (0.3 to 0.9m) of each other.
2. Ensure the U9912-BSW is not already connected (see **Status Indication**).
3. Simultaneously (within 1-2 sec) press and release the PTT button on the U9912-BSW and the controller or gateway to link with.
4. Amber LED's will flash on both devices. A momentary red LED indicates a successful close-link.
5. Upon successful link the U9912-BSW will attempt to establish a connection with the controller/gateway.
6. Upon successfully establishing connection the LED will flash green, a voice alert will be heard (see **Table 1**), and user side-tone will be enabled (see **Communication**).
7. Link and connection are now complete.

Each belt station is able to be linked to only one gateway/controller at a time. A gateway/-controller can have up to six belt stations linked and be connected to four of those six at one time.

### Tip:

Once linked, the devices will not need to be linked again unless they are purged (see **Purging**).

## Status Indications

The power button has a multi-color LED in the center which serves as a status indication for the belt station. **Table 1** below lists these states.

**Table 1: LED Status Indication**

LED Color	Blink Rate	Status
Red	Solid	Initializing/power up
Red	Solid	Close-link successful
Red	Any	Low battery (approx. 1 hr remaining)
Orange	Slow	Idle/Disconnected
Orange	Fast	Link/Connection in progress
Orange	Solid	PTT asserted
Green	Slow	Connected

In addition to the LED, the belt station provides audio feedback for certain conditions as well. **Table 2** below lists these conditions.

**Table 2: Alerts**

"Connection Established"
"Connection Lost"
"Low Battery"
"Connection Deleted" (see <i>Purging</i> )
Triple Beep – Fringe Signal Area

## Operation

### *Power-up/power-down*

To power up the U9912-BSW belt station, press and hold the POWER button for approximately two seconds. The LED will turn red and then begin flashing orange. If the belt station has been linked to a controller or gateway and that controller or gateway is in range, the belt station will automatically connect within a few seconds.

To power down the U9912-BSW, press and hold the POWER button for approximately two seconds. The LED will turn red and then turn off. The belt station is now powered down.

### *Auto Shut-off*

Additionally, the belt station will automatically power down if it is disconnected from its gateway/controller for more than 30 minutes.

### *Headset*

In order for the U9912-BSW to be used, a David Clark H9900-series headset must be connected. To connect the headset, align the connectors as shown then push and turn clockwise (see **Figure 2**). There are separate left and right volume controls on the headset.

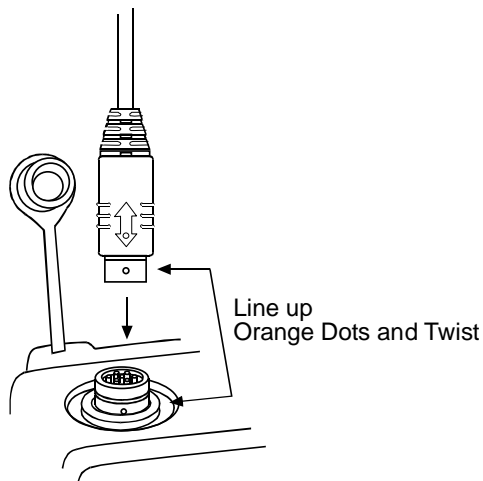

**Figure 2: Headset Connection**

It is also important to properly wear the headset and correctly position the microphone. For optimum noise-cancelling performance, position the microphone 1/8" to 1/4" (3-6 mm) from your lips.



**Figure 3: Wearing the Headset**

### *Communication*

Depending on the gateway or controller the belt station is paired with, operation will vary. In all cases the user will hear his own voice (side-tone) only when the belt station is linked to a controller or gateway and when the PTT is depressed. Side-tone provides feedback for the user to know he is connected and is being heard by the remote users as well. In general, if you can hear your own voice, the other users can hear you as well.

### *Range*

The range of a belt station and a controller/gateway can be up to 300 ft (100m). If you are in an environment with metal or concrete walls, this range could be reduced. If the belt station enters into a "fringe" reception area, a brief sequence of three beeps will be heard in the headset. This is to serve as a warning of a possible disconnection if conditions are not improved. When possible, the user should attempt to regain line-of-sight contact with the controller. When the belt station travels out of range of the controller/gateway, a voice alert will indicate that the connection has been lost. To reconnect, simply move back into range and connection with the controller/gateway will automatically be reestablished, also noted by a voice alert.

### *PTT*

The PTT button allows the user to activate the headset's microphone momentarily while depressed, for communication on the wireless intercom. For more information see the user manual for the appropriate controller or gateway.

### *Low Battery*

Under typical conditions, the battery in the belt station will last up to 24 hours or longer. A voice alert will indicate to the user that the battery is running low. Additionally the Status LED will turn red. At this point, approximately 1 hour of operation remains.

## **Purging**

In some circumstances it may be desired to “purge” the U9912-BSW of its known controller or gateway. Typically purging is not necessary unless there are multiple controllers or gateways in the same vicinity and you wish to link a belt station to a different controller or gateway. A belt station can be linked to only one controller or gateway at a time.

### *Purge Procedure*

1. Power down belt station (see **Power-up/Power-down**).
2. Press and hold PTT button. Do not release.
3. Power up the belt station (see **Power-up/Power-down**).
4. Release POWER button.
5. Release PTT button.
6. A voice alert will indicate that the connection has been deleted.

When this procedure is complete, the belt station will not automatically connect to a controller/gateway and must be linked again.

## **Battery Removal & Charging**

All David Clark 9900-series wireless belt stations and battery operated controllers use a 3.7V Li-Polymer rechargeable battery. This battery is removed by loosening the battery release screw (See **Figure 1**). These batteries are charged with the A99-04CRG 4-bay battery charger (41034G-01).

When installing a battery, take care to align the battery properly and fully tighten the screw (see **Figure 4**).



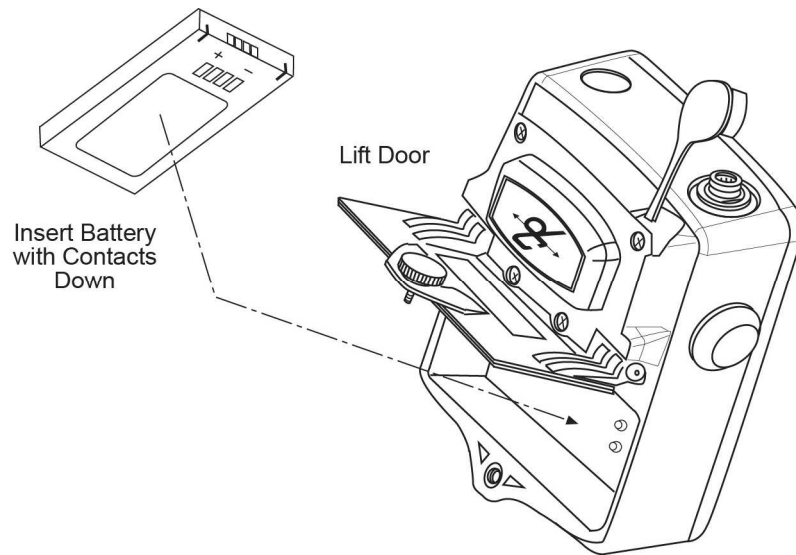

**Figure 4: Battery Insertion/Removal**

## Troubleshooting

**Table 3: Troubleshooting**

<b>Problem</b>	<b>Solution</b>
Controller will not turn on	Review <i>Power-up/Power-down</i> procedure Ensure a fresh battery is installed
Cannot link a belt station	Review <i>Registration</i> procedure Ensure units are within 1 to 3 ft. (0.3 to 0.9m) of each other while linking
No sidetone	Not connected to a Controller/Gateway
Low receive audio	Adjust left/right volume knobs on headset
No audio /intermittent audio	Check headset connection to belt station

## Replacement Parts

- Battery (P/N: 40688G-90)
- Protective skin, black (A99-01SKN, P/N: 40796G-02)

## Care and Maintenance

The U9912-BSW is not user serviceable. Do not attempt to open the enclosure. If this product requires service, please contact the David Clark Co. Inc. Customer Service department:

- **Phone:** 800.298.6235
- **E-Mail:** [serviceWWW@DavidClark.com](mailto:serviceWWW@DavidClark.com)
- **By Mail:** Customer Service  
David Clark Company  
360 Franklin Street  
Worcester, MA 01604

If necessary, the U9912-BSW may be wiped down with a mild soap and water mixture. Although it is a sealed device designed to withstand submersion in water to 1 meter, do not unnecessarily submerge this product in water.

Avoid storage of this product in direct sunlight or high temperature environments.

## Specifications

Frequency Range	1920 MHz - 1930 MHz (U.S. and Canada)
Average RF Power Output	4 mW (100mW peak) (U.S. and Canada)
Range	300 ft (100m) line-of-sight (nominal)
Battery Life	24 hrs continuous use (nominal)
Operating Temperature	-14°F to 113°F (-10°C to +45°C)
Storage Temperature	-4°F to 140°F (-20°C to +60°C)
Power Requirements	3.7V @ 100mA nominal
Battery Type	3.7V 2000mAh Li-Polymer

## FCC Part 15 Statement

### RADIO AND TELEVISION INTERFERENCE

This equipment has been tested and found to comply with the limits for a Class B digital device, pursuant to Part 15 of the FCC rules. These limits are designed to provide reasonable protection against harmful interference in a residential installation. This equipment generates, uses and can radiate radio frequency energy and, if not installed and used in accordance with the instructions,

may cause harmful interference to radio communications. However, there is no guarantee that interference will not occur in a particular installation. If this equipment does cause harmful interference to radio or television reception, which can be determined by turning the equipment off and on, the user is encouraged to try to correct the interference by one or more of the following measures:

- Reorient or relocate the receiving antenna.
- Increase the separation between the equipment and the receiver.
- Connect the equipment into an outlet on a circuit different from that to which the receiver is connected.
- Consult the dealer or an experienced radio/TV technician for help.

You may also find helpful the following booklet, prepared by the FCC: "How to Identify and Resolve Radio-TV Interference Problems." This booklet is available from the U.S. Government Printing Office, Washington D.C. 20402.

\* In order to maintain compliance with FCC regulations shielded cables must be used with this equipment. Operation with non-approved equipment or unshielded cables is likely to result in interference to radio & television reception.

## **Industry Canada Statement**

This device complies with Industry Canada license-exempt RSS standard(s). Operation is subject to the following two conditions: (1) this device may not cause interference, and (2) this device must accept any interference, including interference that may cause undesired operation of the device.

## **Unauthorized Changes**

Changes or modifications not expressly approved by David Clark Company, Inc. could void the users' authority to operate the equipment.

## **Usage Restrictions**

Due to the UPCS frequencies used, this product is licensed for operation only in the United States of America and Canada, and those countries that have approved the DECT 6.0 Standard.

## **SAR Statement**

### **Radio wave exposure and Specific Absorption Rate (SAR) information**

This product has been designed to comply with applicable safety requirements for exposure to radio waves. These requirements are based on scientific guidelines that include safety margins designed to assure the safety of all persons, regardless of age and health. The radio wave exposure guidelines employ a unit of measurement known as the Specific Absorption Rate, or SAR. Tests for SAR are conducted using standardized methods with the product transmitting at its highest certified power level in all used frequency bands. The product is designed to meet the relevant guidelines for exposure to radio waves.

SAR data information for residents in countries that have adopted the SAR limit recommended by the International Commission of Non-Ionizing Radiation Protection (ICNIRP), which is 0.08 W/kg averaged over ten (10) gram of tissue (for example European Union, Japan, Brazil and New Zealand): The highest SAR value for this product when tested for use on the body is 0.275 W/kg.