

SMS100 *Short Message Service (Text) Module*

Maretron's SMS100 is a mobile or cellular modem that automatically sends text message alerts from your vessel to your phone. The SMS100 works together with Maretron's dedicated displays (DSM150/DSM250) or N2KView® software to detect programmable alert conditions from sensors interconnected on an NMEA 2000® network. The displays or N2KView® software instruct the SMS100 to connect to the cellular network and transmit an alert message to selected telephone numbers. Whether it is high bilge water, low battery voltage, unplugged shore power, or an opened hatch or door, the SMS100 quickly alerts you to conditions onboard your vessel that require attention anywhere you have cellular network coverage. You can also send a text message to your vessel, and with the proper sensors installed, the SMS100 will respond with status information including the vessel's position, bilge status, battery and shore power voltage, wind speed, inside and outside temperature.



- Programmable Alerts (Alarms or Warnings) from Maretron Installed Displays and Sensors on the Vessel Automatically Triggers Text Message(s) Sent to Your Phone
- User Can Text Vessel for Status (Position, Bilge Status, Battery and Shore Power Voltage, Wind Speed, Inside and Outside Temp) Which Also Double Checks Communication Path to Ensure Alerts Get Through
- Six Band GSM Modem with Easily Interchangeable mini-SIM Card (SIM Card is User Supplied)
- Dipole Terminal Antenna with Hinged SMA Connector with Versatile Mounting Options
- Waterproof (IP65) Enclosure

Products

PART NUMBER	DESCRIPTION
SMS100-01	SMS (Text) Module

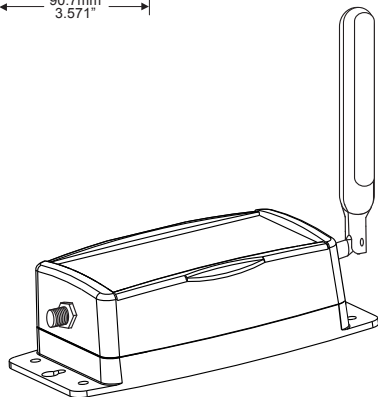
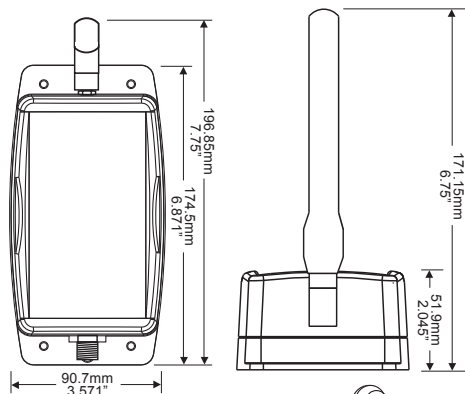

Alert Text

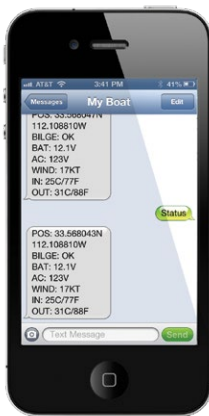

Status Text

NMEA 2000® Parameter Group Numbers (PGNs)

Specifications

Parameter	Value	Comment
NMEA 2000® Connector	DeviceNet Micro-C	Industry Standard Waterproof
NMEA 2000® Isolation	Opto-Isolated	Antenna Connector Isolated from NMEA 2000
Antenna Connector	SMA	For use only with supplied cellular antenna
Cellular Technologies	2G GSM/GPRS/EDGE 3G UMTS/HSDPA/HSUPA	
Supported Bands	800/850/900/1700/ 1900/2100 MHz	

Certifications

Parameter	Comment
NMEA 2000® Standard	Level A
Maritime Navigation and Radiocommunication Equipment & Systems	IEC 61162-3
Maritime Navigation and Radiocommunication Equipment & Systems	IEC 60945
FCC and R&TTE/CE Mark	Electromagnetic Compatibility
PTCRB	
AT&T	Network Ready

Electrical

Description	PGN #	PGN Name	Default Rate
Response to Requested PGNs	126464	PGN List (Transmit and Receive)	N/A
	126996	Product Information	N/A
	126998	Configuration Information	N/A
Protocol PGNs	059392	ISO Acknowledge	N/A
	059904	ISO Request	N/A
	060416	ISO Transport Protocol, Connection Management	N/A
	060160	ISO Transport Protocol, Data Transfer	N/A
	060928	ISO Address Claim	N/A
	065240	ISO Address Command	N/A
	126208	NMEA Request/Command/Acknowledge	N/A
Periodic PGNs	130834	SMS Status (Maretron Proprietary)	10 seconds
	130835	SMS Text Message (Maretron Proprietary)	On Receipt

Parameter	Value	Comment
Operating Voltage	9 to 32 Volts	DC Voltage
Power Consumption	<150mA	Average Current Drain
Load Equivalence Number (LEN)	3	NMEA 2000® Spec. (1LEN = 50 mA)
Reverse Battery Protection	Yes	Indefinitely
Load Dump Protection	Yes	Energy Rated per SAE J1113

Mechanical

Parameter	Value	Comment
Size	6.871" x 3.571" x 2.045" (174.5mm x 90.7mm x 51.9mm)	Including Flanges for Mounting
Weight	10.6 oz. (301 g)	

Environmental

Parameter	Value
IEC 60945 Classification	Exposed
Degree of Protection	IP65
Operating Temperature	-25°C to 55°C
Storage Temperature	-40°C to 85°C
Relative Humidity	93%RH @40° per IEC60945-8.2
Vibration	2-13.2Hz @ ±1mm, 13.2-100Hz @ 7m/s ² per IEC 60945-8.7
Rain and Spray	12.5mm Nozzle @ 100liters/min from 3m for 30min per IEC 60945-8.8
Solar Radiation	Ultraviolet B, A, Visible, and Infrared per IEC 60945-8.10
Corrosion (Salt Mist)	4 times 7days @ 40°C, 95%RH after 2 hour Salt Spray Per IEC 60945-8.12
Electromagnetic Immunity	Conducted, Radiated, Fast Transient, Supply, and ESD per IEC 60945-10
Safety Precautions	Dangerous Voltage, Electromagnetic Radio Frequency per IEC 60945-12