

NBE100 *Network Bus Extender*

Maretron's NBE100 allows you to go beyond the maximum NMEA 2000® network design rules and extend an NMEA 2000® network to two, three, four, and even five times larger than normal. The NBE100 also solves problems associated with network errors and other electrical issues caused by exceeding NMEA 2000® rules and it simplifies the design of large networks.

NMEA 2000® network rules allow a maximum of 50 products connected on a single network, a maximum trunk length of 200 meters, and a maximum drop length of 78 meters. If you have a network that exceeds any of these specifications, you can simply extend the network trunk by inserting the NBE100, along with the additional termination resistors and powertaps. This will split the network into multiple electrical segments allowing 50 products per segment. The NBE100 will transparently route NMEA 2000® messages between multiple network segments, making them work as a single logical NMEA 2000® network.

Lastly, the NBE100 can be used to build redundant networks or isolate certain network segments so that if one segment is compromised, the other segments continue to operate.



- Segments a single large NMEA 2000® network into smaller multiple electrical segments.
- Allows you to exceed the 50 product limitation on a NMEA 2000® network.
- Allows you to exceed the 200 meter trunk length limitation on a NMEA 2000® network.
- Allows you to exceed the 78 meter drop lengths limitation on a NMEA 2000® networks.
- Allows all NMEA 2000® devices to operate as if they were still on a single NMEA 2000® network.
- Optically isolates network segments, increasing signal integrity and network reliability.

Products

PART NUMBER	DESCRIPTION
NBE100-01	NMEA 2000® Network Bus Extender



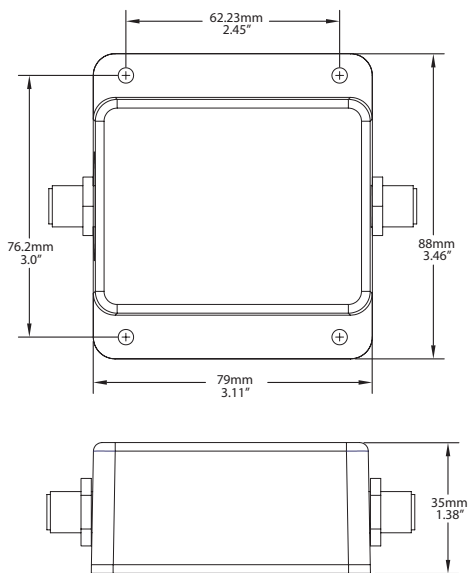

Certifications

Parameter	Comment
NMEA 2000® Standard	Level A
Maritime Navigation and Radiocommunication Equipment & Systems	IEC 61162-3
Maritime Navigation and Radiocommunication Equipment & Systems	IEC 60945
FCC and CE Mark	Electromagnetic Compatibility

NMEA 2000® Parameter Group Numbers (PGNs)

Description	PGN #	PGN Name	Default Rate
Response to Requested PGNs	126464	PGN List (Transmit and Receive)	N/A
	126996	Product Information	N/A
	126998	Configuration Information	N/A
Protocol PGNs	059392	ISO Acknowledge	N/A
	059904	ISO Request	N/A
	060928	ISO Address Claim	N/A
	065240	ISO Address Command	N/A
	126208	NMEA Request/Command/Acknowledge	N/A
Maretron Proprietary PGNs	126720	Configuration	N/A

Electrical

Parameter	Value	Comment
Operating Voltage	9 to 16 Volts	DC Voltage
Power Consumption	<150mA	Average Current Drain
Load Equivalence Number (LEN)	3	NMEA 2000® Spec. (1LEN = 50 mA)
Reverse Battery Protection	Yes	Indefinitely
Load Dump Protection	Yes	Energy Rated per SAE J1113

Mechanical

Parameter	Value	Comment
Size	3.11" x 3.46" x 1.38" (79mm x 88mm x 35mm)	Including Flanges for Mounting
Weight	8 oz. (227 g)	

Environmental

Parameter	Value
IEC 60945 Classification	Exposed
Degree of Protection	IP67
Operating Temperature	-25°C to 55°C
Storage Temperature	-40°C to 70°C
Relative Humidity	93%RH @40° per IEC60945-8.2
Vibration	2-13.2Hz @ ±1mm, 13.2-100Hz @ 7m/s ² per IEC 60945-8.7
Rain and Spray	12.5mm Nozzle @ 100liters/min from 3m for 30min per IEC 60945-8.8
Solar Radiation	Ultraviolet B, A, Visible, and Infrared per IEC 60945-8.10
Corrosion (Salt Mist)	4 times 7 days @ 40°C, 95%RH after 2 hour Salt Spray Per IEC 60945-8.12
Electromagnetic Emission	Conducted and Radiated Emission per IEC 60945-9
Electromagnetic Immunity	Conducted, Radiated, Supply, and ESD per IEC 60945-10
Safety Precautions	Dangerous Voltage, Electromagnetic Radio Frequency per IEC 60945-12

Network Extension Side-to-Side Example

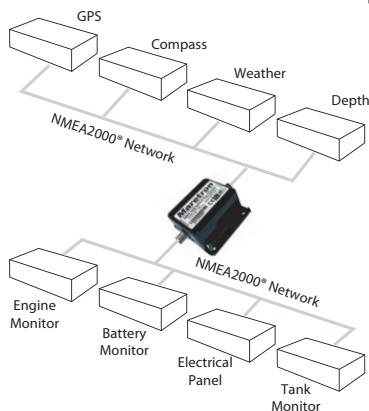

Network Extension End-to-End Example

