

INSTALLATION INSTRUCTIONS

Product

7160-0244

Vehicle Base, Ford Fusion

Revision

Rev A

Form

INST-472



WARNING



- You must read and follow all of these installation instructions. Failure to follow the installation instructions may result in serious bodily injury or death.
- Do not install or use the 7160-0244 Assembly in the area in which the airbag on the vehicle may be deployed. The installer and user of the 7160-0244 Assembly are responsible for installing and using the 7160-0244 Assembly outside the area in which an airbag may be deployed. (See Product Mounting Disclaimer Below)
- Keep these installation instructions with the product and readily available in the vehicle for future reference of other users of the product.
- Additional copies of the installation instructions can be obtained from Gamber-Johnson. If you need assistance or have any questions, call Gamber-Johnson at 1-800-456-6868.
- Do not remove warning label from product under any circumstances.

Tools Needed

- (1) T27 Torx Bit
- (1) 15 mm Socket
- (2) 9/16 wrenches (one needs to be an open end)

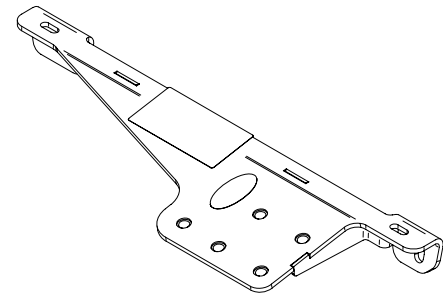

Installation

1. Begin by sliding the front passenger's seat to its forward most extent. This will allow access to the rear seat bolts. Remove the rear seat bolts.
2. Slide the seat back to allow access to the front seat bolts. Remove the front seat bolts.
3. Lift the seat exposing the underside. Take note of the brackets on each seat rail and the bolts that hold the brackets to the seat rails. (see **FIG. 1**)



FIG. 1
Seat Rails and
Brackets

Product Mounting Disclaimer

Gamber-Johnson is not liable under any theory of contract or tort law for any loss, damage, personal injury, special, incidental or consequential damages for personal injury or other damage of any nature arising directly or indirectly as a result of the improper installation or use of its products in vehicle or any other application. In order to safely install and use Gamber-Johnson products full consideration of vehicle occupants, vehicle systems (i.e., the location of fuel lines, brakes lines, electrical, drive train or other systems), air-bags and other safety equipment is required. Gamber-Johnson specifically disclaims any responsibility for the improper use or installation of its products not consistent with the original vehicle manufactures specifications and recommendations, Gamber-Johnson product instruction sheets, or workmanship standards as endorsed through the Gamber-Johnson Certified Installer Program.

If you need assistance or have questions, call Gamber-Johnson at 1-800-456-6868

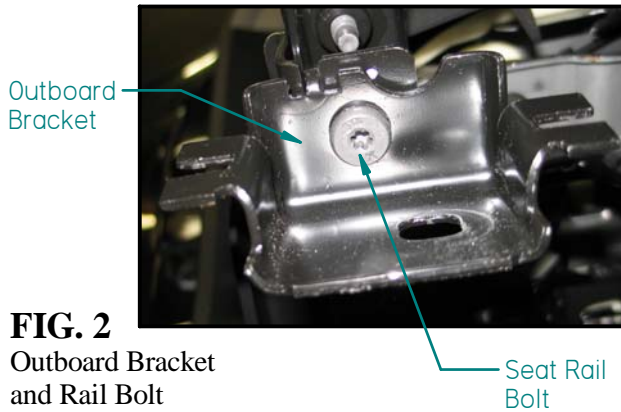

FIG. 2
Outboard Bracket
and Rail Bolt

4. Remove the rail bolt (see FIG. 2), using a T27 Torx Bit, and subsequently the bracket from each of the outboard and inboard seat rails.

5. Use the two rail bolts that were removed to attach the vehicle base to the seat rails. **DO NOT tighten bolts all the way.**

6. Replace the seat/vehicle base assembly to the seat's original position. Align seat bolt holes and fasten seat/vehicle base assembly to the vehicle floor.

7. Once the base is tight to the floor, fully tighten the two seat rail bolts.

8. Assemble the 3/8-16 x 2.75" Hex Head Bolt and 3/8 Washer into the base as shown in FIG. 3.

9. Assemble the 3/8-16 Nut and Leveler Foot as shown in FIG. 3. Fasten Leveler Foot until finger tight onto bottom of 3/8-16 x 2.75" Bolt.

10. Tightly fasten the bolt/washer to the top surface of the base driving the Leveler Foot into the floor of the vehicle.

11. Continuing to hold the wrench on the bolt, use a second wrench to rotate the Leveler Foot (further compressing the floor) no more than four full rotations. Tighten the 3/8-16 Nut to the Leveler Foot to complete the installation

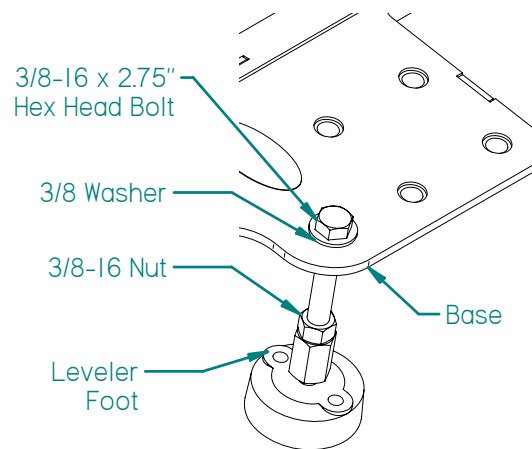

FIG. 3
Leveler Foot Assembly



- The 7160-0244 Assembly should not be positioned in the area where the airbag may be deployed.

- DO NOT position the equipment in front of an airbag. Equipment positioned in front of an airbag may cause serious injury or death if an airbag is activated.

- If installation of the equipment requires that the equipment be placed in front of an airbag, the airbag should be deactivated. In order to secure permission for deactivating the airbag you must contact the National Highway Traffic Safety Administration at 1-800-424-9393 to gain permission to do so. If you have any questions or need assistance, call Gamber-Johnson at 1-800-456-6868.

- High speed vehicle turns may cause parts of the assembly to swivel, interfering with the driver or other equipment.