

DEFINING RUGGED

EXCEPTIONAL ENGINEERING | ROCK SOLID | EXTENSIVE TESTING

NOTEPAD™ V CRADLE ACCESSORIES: LED LIGHT ASSEMBLY

Placement	Weight	Height	Width	Depth
Attaches to any corner using pre-drilled slots on the <i>NotePad™ V Universal Computer Mount</i> (Item No. 7160-0250 or 7160-0250-01, 7160-0250-02, 7160-0402)	0.5 lbs	12.0"	3.0"	1.56"

Features:

- Rugged construction for long-term durability
- Flexible design
- On/off switch allows you two (2) different LED color combinations:
 - Red
 - White

Item No. **7160-0252**

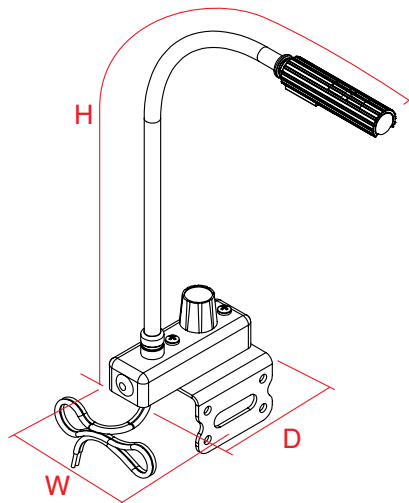

Very Well Connected™

3001 Borham Ave. | Stevens Point, WI 54481, USA
Phone: 715.344-3482 | Toll-free: 800.487-9220 | Fax: 715.344-5209
Email: gamberj@gamberjohnson.com | Website: www.gamberjohnson.com

Follow us on:

This document, including images, may not be reproduced partly or fully without the expressed written consent of Gamber-Johnson's Marketing Department.
© Copyright 2013 Gamber-Johnson LLC