

# DEFINING RUGGED

EXCEPTIONAL ENGINEERING | ROCK SOLID | EXTENSIVE TESTING



## MCS TRUNK SHelf OPTIONS: DODGE CHARGER POLICE VEHICLE (2011-2015)

Description	Drilling Required	Weight	Height	Width	Depth
Upper Shelf only	No	27.5 lbs	6.8"	48.9"	21.7"

### Features:

- Strong, lightweight aluminum alloy
- Rugged construction for long term durability
- Upper tray slides on heavy-duty ball bearing slides and can latch securely in the closed and open position
- Available mounting space 37.75" W x 18.5" D

Item No. **7160-0336**

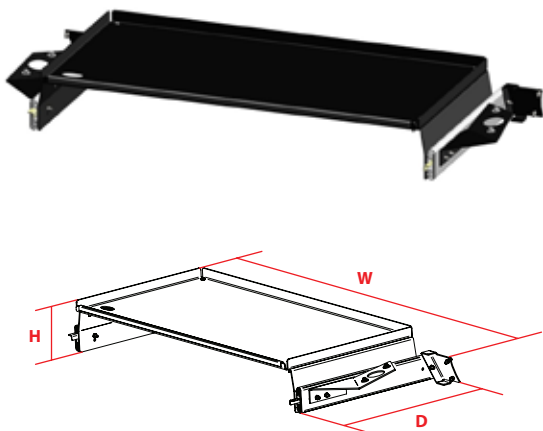

Very Well Connected™

3001 Borham Ave. | Stevens Point, WI 54481, USA  
Phone: 715.344-3482 | Toll-free: 800.487-9220 | Fax: 715.344-5209  
Email: [gamberj@gamberjohnson.com](mailto:gamberj@gamberjohnson.com) | Website: [www.gamberjohnson.com](http://www.gamberjohnson.com)

Follow us on:



This document, including images, may not be reproduced partly or fully without the expressed written consent of Gamber-Johnson's Marketing Department.  
© Copyright 2013 Gamber-Johnson LLC