

DEFINING RUGGED

EXCEPTIONAL ENGINEERING | ROCK SOLID | EXTENSIVE TESTING

SHOCK/VIBRATION ISOLATOR PLATE

Placement	Weight	Height	Width	Depth
Positioned between any Motion Attachment and <i>Gamber-Johnson Docking Station or Cradle</i>	2.43 lbs	0.85"	7.0"	6.5"

Features:

- Highly recommended for non-rugged laptop computers
- Protects equipment from shock and vibration wear
- Can support computer and cradle combined weight of up to 30 lbs.

Item No. **7160-0351**

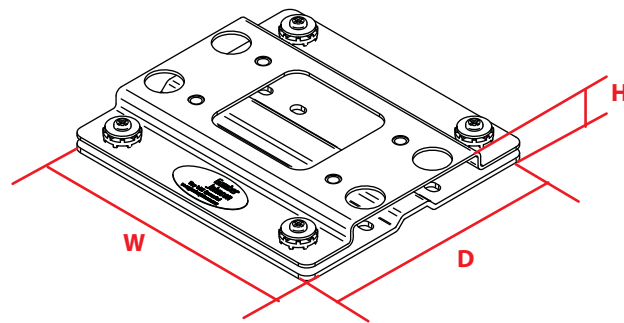

3001 Borham Ave. | Stevens Point, WI 54481, USA
Phone: 715.344-3482 | Toll-free: 800.487-9220 | Fax: 715.344-5209
Email: gamberj@gamberjohnson.com | Website: www.gamberjohnson.com

This document, including images, may not be reproduced partly or fully without the expressed written consent of Gamber-Johnson's Marketing Department. © Copyright 2012 Gamber-Johnson LLC