

# DEFINING RUGGED

EXCEPTIONAL ENGINEERING | ROCK SOLID | EXTENSIVE TESTING



## FORKLIFT MOUNT: DUAL CLAM SHELL WITH SMALL PLATE

Placement	Tilt	Swivel	Weight	Height	Width	Depth
Attaches to rectangular overhead guard leg 1.5" to 2.5" wide	Yes - up to a combined total of 160°	Motion Attachment - 360°	5.7 lbs.	9.77"	7.26"	6.96"

### Secondary Clam Features:

- Heavy gauge steel construction for long-term durability in a rugged environment
- Black powdercoat finish for maximum corrosion resistance
- *Clam Shell* features the following hole patterns: AMPS, NEC and VESA 75mm
- To tilt the *Clam Shell* simply loosen the adjustable lever, tilt to desired position and then re-tighten the lever
- A secondary bolt is included to lock the clam shell into a permanent position

### Small Plate Features:

- Heavy gauge steel construction for long-term durability in a rugged environment
- Black powdercoat finish for maximum corrosion resistance
- *Clam Shell* features the following hole patterns: AMPS, NEC and VESA 75mm
- To tilt the *Clam Shell* simply loosen the adjustable lever, tilt to desired position and then re-tighten the lever
- A secondary bolt is included to lock the clam shell into a permanent position
- Plate sandwiches the overhead guard leg and allows user to position the device at the desired height position

Item No. **7160-0366**

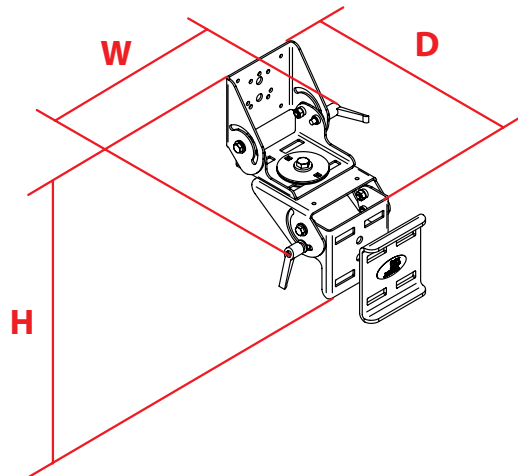

3001 Borham Ave. | Stevens Point, WI 54481, USA  
 Phone: 715.344.3482 | Toll-free: 800.487.9220 | Fax: 715.344.5209  
 Email: [gamberj@gamberjohnson.com](mailto:gamberj@gamberjohnson.com) | Website: [www.gamberjohnson.com](http://www.gamberjohnson.com)

Follow us on:



This document, including images, may not be reproduced partly or fully without the expressed written consent of Gamber-Johnson's Marketing Department.  
 © Copyright 2014 Gamber-Johnson LLC