

# DEFINING RUGGED

EXCEPTIONAL ENGINEERING | ROCK SOLID | EXTENSIVE TESTING



## FORKLIFT MOUNT: CLAM SHELL WITH LARGE PLATE

| Placement  | Tilt                          | Swivel    | Weight   | Height | Width | Depth |
|--|-------------------------------|-----------|----------|--------|-------|-------|
| Attaches to rectangular overhead guard leg 2.5" to 5.0" wide | <b>Yes</b> - up to 160° total | <b>No</b> | 5.8 lbs. | 4.6"   | 6.8"  | 5.28" |

### Features:

- Heavy gauge steel construction for long-term durability in a rugged environment
- Black powdercoat finish for maximum corrosion resistance
- *Clam Shell* features the following hole patterns: AMPS, NEC and VESA 75mm
- The *Clam Shell* can be tilted up or down for a total of 160°
- To tilt the *Clam Shell* simply loosen the adjustable lever, tilt to desired position and then re-tighten the lever
- A secondary bolt is included to lock the clam shell into a permanent position
- Plate sandwiches the overhead guard leg and allows user to position the device at the desired height position

Item No. **7160-0370**

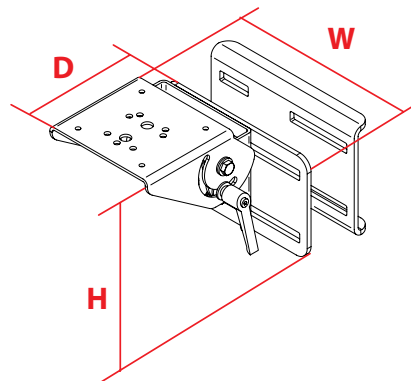

Very Well Connected™

3001 Borham Ave. | Stevens Point, WI 54481, USA  
Phone: 715.344.3482 | Toll-free: 800.487.9220 | Fax: 715.344.5209  
Email: [gamberj@gamberjohnson.com](mailto:gamberj@gamberjohnson.com) | Website: [www.gamberjohnson.com](http://www.gamberjohnson.com)

Follow us on:



This document, including images, may not be reproduced partly or fully without the expressed written consent of Gamber-Johnson's Marketing Department.  
© Copyright 2014 Gamber-Johnson LLC