

DEFINING RUGGED

EXCEPTIONAL ENGINEERING | ROCK SOLID | EXTENSIVE TESTING



CHEVROLET CAPRICE POLICE PATROL VEHICLE (2011-2013)

Placement	Seat Configurations	Drilling Required	Recommended Pole Solution	Weight	Height	Width	Depth
Attaches to inboard and outboard passenger side seat studs	Bucket	No - attaches to seat studs: <i>Chevrolet Caprice Police Patrol Vehicle (2011-2013)</i>	Lower Tube: DS-LOWER-9 Upper Pole: 7160-0178 Support Brace: 7160-0230 Motion Attachment: Mongoose (7160-0220) Tubes/Poles and Motion Attachments ordered separately	7.3 lbs	4.2"	21.1	9.8"

Features:

- Heavy gauge steel construction for long-term durability
- Black powdercoat finish for maximum corrosion resistance
- Vehicle Base works with Chevrolet Caprice Police Patrol Vehicle (9C1 and 9C3)
- Angled step moves pole away from passenger leg space
- Vehicle base includes a cover plate that protects OEM air bag and power wiring harness
- Notched cut-out for floor mat pegs (for use if the carpet option is selected)
- A *Support Brace* (Item No. 7160-0230) is highly recommended

Item No. 7160-0381

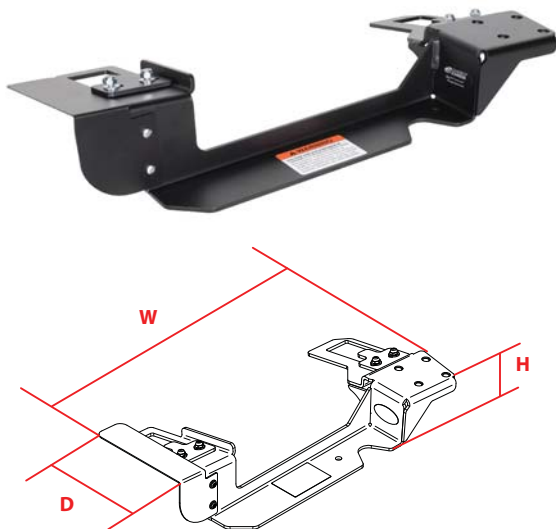

3001 Borham Ave. | Stevens Point, WI 54481, USA
 Phone: 715.344-3482 | Toll-free: 800.487-9220 | Fax: 715.344-5209
 Email: gamberj@gamberjohnson.com | Website: www.gamberjohnson.com

This document, including images, may not be reproduced partly or fully without the expressed written consent of Gamber-Johnson's Marketing Department. © Copyright 2013 Gamber-Johnson LLC