

DEFINING RUGGED

EXCEPTIONAL ENGINEERING | ROCK SOLID | EXTENSIVE TESTING



MCS VEHICLE SPECIFIC CONSOLE BOX ONLY: FORD SEDAN POLICE INTERCEPTOR (2012-2015)

Placement	Seat Configuration	Drilling Required	Weight	Lower Height (LH)	Overall Height	Width	Depth
On top of transmission hump	Bucket	No - attaches to transmission hump	18.0 lbs.	4.1" to 6.6"	11.5"	9.0"	27.0"

Features:

- Heavy gauge steel, fully welded constructed for long-term durability
- Black powdercoat finish for maximum corrosion resistance
- Low profile no-drill vehicle specific console
- Vertical angled section accommodates 6" of mounting space
- Horizontal low profile section accommodates 11.5" of mounting space (with internal cupholder 7.0" of mounting space)
- 6 fasteners for mounting to transmission hump
- Removable top plate
- Removable center brace
- Fully welded construction for long term product life span
- Threaded pems provided for mounting armrest to the console
- 12 volt plug insert (located on passenger side)
- Computer can be mounted in the center or offset on the smiley face pattern located on the top of the console (accommodates any Universal Display Bracket Mount or any Gamber-Johnson Motion Attachment ordered separately)
- Will ship fully assembled
- 3 faceplates and 3 filler panels are included

Note: Does not require a leg kit or top plate, bolts directly to the vehicle

Item No. 7160-0410

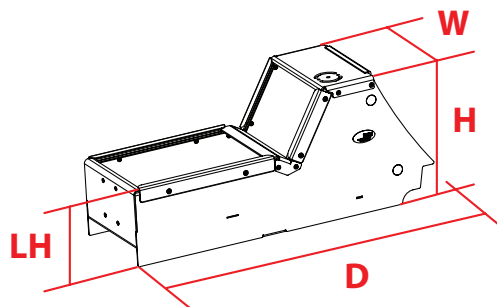

Very Well Connected™

3001 Borham Ave. | Stevens Point, WI 54481, USA
 Phone: 715.344-3482 | Toll-free: 800.487-9220 | Fax: 715.344-5209
 Email: gamberj@gamberjohnson.com | Website: www.gamberjohnson.com

Follow us on:



This document, including images, may not be reproduced partly or fully without the expressed written consent of Gamber-Johnson's Marketing Department.
 © Copyright 2012 Gamber-Johnson LLC