

INSTALLATION INSTRUCTIONS

Product
7160-0438

Revision
Rev.A

Form
INST-575

Description NGPI SEDAN TRUNK SHELF, 2012+

Printing Spec:PS-001

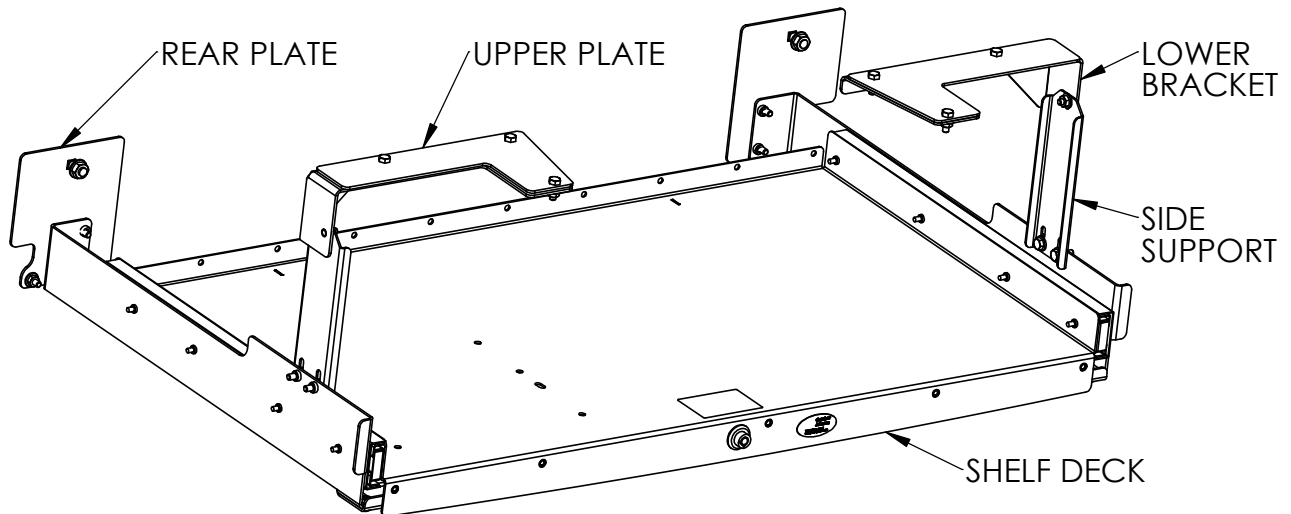

1. Remove rear seat cushion and back rest
2. Remove C pillar trim panel from both sides of vehicle
3. Remove the parcel shelf carpet/board
4. Remove factory installed trunk shelf if so equipped. Factory trunk shelf is attached with 5 nuts accessible from between the rear windshield and parcel shelf.
5. Screw three (3) ¼-20x3/4 bolts into each of the Upper Plates as shown (Fig. 1). Note plates are the same however installing the bolts creates a left hand and right hand Upper Plate.1.
6. Set the plates into the factory holes in the parcel shelf (Fig. 2). Drivers side shown.

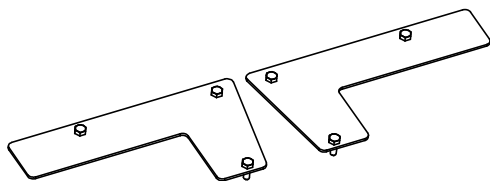

Fig 1 - Upper Plates Assembly



Fig 2 - Upper Plate Placement

Product Mounting Disclaimer

Gamber-Johnson is not liable under any theory of contract or tort law for any loss, damage, personal injury, special, incidental or consequential damages for personal injury or other damage of any nature arising directly or indirectly as a result of the improper installation or use of its products in vehicle or any other application. In order to safely install and use Gamber-Johnson products full consideration of vehicle occupants, vehicle systems (i.e., the location of fuel lines, brakes lines, electrical, drive train or other systems), air-bags and other safety equipment is required. Gamber-Johnson specifically disclaims any responsibility for the improper use or installation of its products not consistent with the original vehicle manufactures specifications and recommendations, Gamber-Johnson product instruction sheets, or workmanship standards as endorsed through the Gamber-Johnson Certified Installer Program.

© copyright 2011 Gamber-Johnson, LLC

If you need assistance or have questions, call Gamber-Johnson at 1-800-456-6868

7. From inside the trunk, screw the Lower Brackets onto the bolts from the Upper Plates using the provided flat washers and nylock nuts (Fig. 3). Drivers side shown.
8. Outside of the vehicle, loosely attach the Side Supports to the Shelf Deck using the provided ¼-20x3/4 bolts and flat washers (Fig. 4)
9. Carefully slide the trunk shelf assembly into the vehicle trunk. Lift the trunk shelf assembly and hook the Side Supports onto the studs in the Lower Brackets (Fig. 4)
10. Install and hand tighten the provided flat washer and nylock nuts to the studs in the Lower Brackets.
11. From in the passenger compartment, attach the Rear Plates to the factory hole in the seat back using the provided 3/8" carriage bolts, washers and nylock nuts (Fig. 5)
12. Install the four (4) ¼-20 x ¾ bolts and washers through the Rear Plate and into the threaded inserts in the back of the trunk shelf.
13. Optional but recommended: The fourth hole in the Rear Plate should line up with the lip of the wheel well. Make sure the Rear Plate is parallel to the body crease then mark and drill a hole into the flange and secure with the provided ¼-20 x ¾ bolts, washers and nylock nuts.
14. Tighten the bolts and nuts on the Side Supports
15. Check the trunk shelf for proper latching and extension. It may be required to cut some of the trunk liner to avoid interference with the trunk shelf operation
16. Reassemble vehicle interior in reverse direction of disassembly

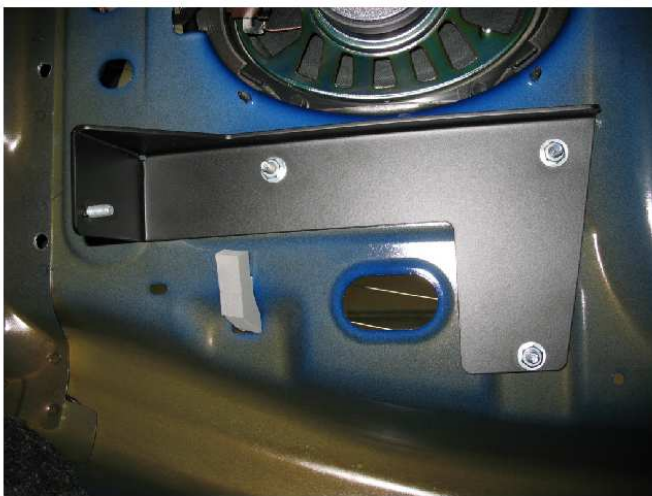

Fig 3 - Upper Plate Mounting

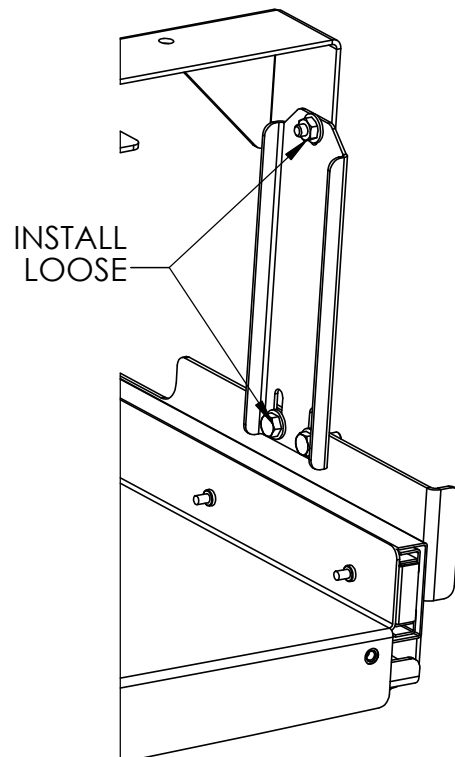

Fig 4 - Side Support Assembly



Fig 5 - Rear Plate Installation