

ASTRO[®]

XTS[™] 2500

XTS[™] 2500I

XTS[™] 2250

XTS[™] 1500

MT 1500

PR 1500

Portable Radios

Detailed Service Manual



Foreword

The information contained in this manual relates to all ASTRO® XTS™ 2500 / XTS™ 2500I / XTS™ 2250 / XTS™ 1500 digital portable radios and MT 1500 and PR 1500 portable radios, unless otherwise specified. This manual provides sufficient information to enable qualified service shop technicians to troubleshoot and repair a radio to the component level.

For details on the operation of the radio or level 1 or 2 maintenance procedures, refer to the applicable manuals, which are available separately. A list of publications is provided in this manual in the section, "[Related Publications](#)" on page xxiv.

Safety Information

Before operating a radio, please read the RF energy awareness information and operating instructions in the Product Safety and RF Exposure booklet enclosed with your radio (Motorola Publication part number 68P81095C98) to ensure compliance with RF energy exposure limits.

Manual Revisions

Changes which occur after this manual is printed are described in PMRs (Publication Manual Revisions). These PMRs provide complete replacement pages for all added, changed, and deleted items, including pertinent parts list data, schematics, and component layout diagrams.

Computer Software Copyrights

The Motorola products described in this manual may include copyrighted Motorola computer programs stored in semiconductor memories or other media. Laws in the United States and other countries preserve for Motorola certain exclusive rights for copyrighted computer programs, including, but not limited to, the exclusive right to copy or reproduce in any form the copyrighted computer program. Accordingly, any copyrighted Motorola computer programs contained in the Motorola products described in this manual may not be copied, reproduced, modified, reverse-engineered, or distributed in any manner without the express written permission of Motorola. Furthermore, the purchase of Motorola products shall not be deemed to grant either directly or by implication, estoppel, or otherwise, any license under the copyrights, patents or patent applications of Motorola, except for the normal non-exclusive license to use that arises by operation of law in the sale of a product.

Documentation Copyrights

No duplication or distribution of this document or any portion thereof shall take place without the express written permission of Motorola. No part of this manual may be reproduced, distributed, or transmitted in any form or by any means, electronic or mechanical, for any purpose without the express written permission of Motorola.

Disclaimer

The information in this document is carefully examined, and is believed to be entirely reliable. However no responsibility is assumed for inaccuracies. Furthermore, Motorola reserves the right to make changes to any products herein to improve readability, function, or design. Motorola does not assume any liability arising out of the applications or use of any product or circuit described herein; nor does it cover any license under its patent rights nor the rights of others.

Trademarks

MOTOROLA, the Stylized M logo, and ASTRO are registered in the US Patent & Trademark Office. All other products or service names are property of their respective owners.

© Motorola, Inc. 2007

Document History

The following major changes have been implemented in this manual since the previous edition:

Edition	Description	Date
6816985H01-A	Initial Release	April, 2006
6816985H01-B	Added UHF1, UHF2, 700/800 MHz and 900MHz information.	Aug., 2007

Notes

Table of Contents

Foreword	ii
Safety Information.....	ii
Manual Revisions	ii
Computer Software Copyrights.....	ii
Documentation Copyrights	ii
Disclaimer	ii
Trademarks.....	ii
Document History	iii
Chapter 1 Introduction	1-1
1.1 General.....	1-1
1.2 Notations Used in This Manual	1-1
Chapter 2.1 VHF Overall Characteristics	2.1-1
2.1.1 Introduction.....	2.1-1
2.1.2 Analog Mode of Operation-Receiving	2.1-1
2.1.3 Analog Mode of Operation-Transmitting	2.1-2
2.1.4 ASTRO Mode (Digital Mode) of Operation	2.1-2
2.1.5 Main Board Overview	2.1-2
2.1.6 Vocoder Circuitry Overview	2.1-3
Chapter 2.2 UHF1 Overall Characteristics.....	2.2-1
2.2.1 Introduction.....	2.2-1
2.2.2 Analog Mode of Operation-Receiving	2.2-1
2.2.3 Analog Mode of Operation-Transmitting	2.2-2
2.2.4 ASTRO Mode (Digital Mode) of Operation	2.2-2
2.2.5 Main RF Board Overview	2.2-2
2.2.6 Vocoder Circuitry Overview	2.2-3
Chapter 2.3 UHF2 Overall Characteristics.....	2.3-1
2.3.1 Introduction.....	2.3-1
2.3.2 Analog Mode of Operation-Receiving	2.3-1
2.3.3 Analog Mode of Operation-Transmitting	2.3-2
2.3.4 ASTRO Mode (Digital Mode) of Operation	2.3-2
2.3.5 Main RF Board Overview	2.3-2
2.3.6 Vocoder Circuitry Overview	2.3-3

Chapter 2.4	700/800 MHz Overall Characteristics.....	2.4-1
2.4.1	Introduction.....	2.4-1
2.4.2	Analog Mode of Operation-Receiving.....	2.4-1
2.4.3	Analog Mode of Operation-Transmitting.....	2.4-2
2.4.4	ASTRO Mode (Digital Mode) of Operation.....	2.4-2
2.4.5	Main Board Overview.....	2.4-2
2.4.6	Vocoder Circuitry Overview.....	2.4-3
Chapter 2.5	900MHz Overall Characteristics.....	2.5-1
2.5.1	Introduction.....	2.5-1
2.5.2	Analog Mode of Operation-Receiving.....	2.5-1
2.5.3	Analog Mode of Operation-Transmitting.....	2.5-2
2.5.4	ASTRO Mode (Digital Mode) of Operation.....	2.5-2
2.5.5	Main Board Overview.....	2.5-2
2.5.6	Vocoder Circuitry Overview.....	2.5-3
Chapter 3.1	VHF Radio Power.....	3.1-1
3.1.1	Introduction.....	3.1-1
3.1.2	Radio Power Up or Down.....	3.1-1
3.1.3	General.....	3.1-1
3.1.4	B+ Routing for VHF Band Main Board.....	3.1-2
3.1.5	B+ and +5V Routing for VOCON.....	3.1-3
Chapter 3.2	UHF1 Radio Power.....	3.2-1
3.2.1	Introduction.....	3.2-1
3.2.2	Radio Power Up or Down.....	3.2-1
3.2.3	General.....	3.2-1
3.2.4	B+ Main Board Routing.....	3.2-2
3.2.5	B+ and +5V Routing for VOCON.....	3.2-3
Chapter 3.3	UHF2 Radio Power.....	3.3-1
3.3.1	Introduction.....	3.3-1
3.3.2	Radio Power Up or Down.....	3.3-1
3.3.3	General.....	3.3-1
3.3.4	B+ Routing for UHF2 Band Main Board.....	3.3-2
3.3.5	B+ and +5V Routing for VOCON.....	3.3-3
Chapter 3.4	700/800 MHz Radio Power.....	3.4-1
3.4.1	Introduction.....	3.4-1
3.4.2	Radio Power Up or Down.....	3.4-1
3.4.3	General.....	3.4-1
3.4.4	B+ Routing for 700/800 MHz Band Main Board.....	3.4-2
3.4.5	B+ and +5V Routing for VOCON.....	3.4-3

Chapter 3.5	900 MHz Radio Power	3.5-1
3.5.1	Introduction.....	3.5-1
3.5.2	Radio Power Up or Down.....	3.5-1
3.5.3	General.....	3.5-1
3.5.4	B+ Routing for 900 MHz Band Main Board	3.5-2
3.5.5	B+ and +5V Routing for VOCON.....	3.5-3
Chapter 4.1	VHF Detailed Theories of Operation.....	4.1-1
4.1.1	Introduction.....	4.1-1
4.1.2	Frequency Synthesis.....	4.1-1
4.1.3	Antenna Switch	4.1-2
4.1.4	Receiver	4.1-2
4.1.4.1	Front End	4.1-3
4.1.4.2	Back End	4.1-3
4.1.5	Transmitter	4.1-4
4.1.6	VOCON Functional Blocks	4.1-5
4.1.6.1	Controller and Memory Section	4.1-5
4.1.6.1.1	Patriot IC (U800).....	4.1-5
4.1.6.1.2	SRAM (U804)	4.1-8
4.1.6.1.3	Flash Memory (U803).....	4.1-8
4.1.6.2	Audio and Power Section	4.1-10
4.1.6.2.1	MAKO IC (U701).....	4.1-10
4.1.6.2.2	Regulator	4.1-11
4.1.6.2.3	Audio Pre-Amplifier.....	4.1-11
4.1.6.2.4	Audio Power Amplifier	4.1-11
4.1.6.3	Interface Support Section	4.1-12
4.1.6.3.1	MAKO IC U701	4.1-12
4.1.6.3.2	ESD Protection Circuitry	4.1-13
4.1.6.3.3	Universal Connector (Side Connector) Interface Circuitry.....	4.1-13
4.1.6.3.4	The Option Board	4.1-15
4.1.6.3.5	Encryption Module.....	4.1-16
4.1.6.3.6	System Clocks	4.1-17
4.1.6.4	Transmit Audio Path	4.1-17
4.1.6.5	Receive Audio Path	4.1-18
Chapter 4.2	UHF1 Detailed Theories of Operation	4.2-1
4.2.1	Introduction.....	4.2-1
4.2.2	Frequency Synthesis.....	4.2-1
4.2.3	Antenna Switch	4.2-2
4.2.4	Receiver	4.2-3
4.2.4.1	Front End	4.2-3
4.2.4.2	Back End	4.2-4
4.2.5	Transmitter	4.2-4
4.2.6	VOCON Functional Blocks	4.2-5
4.2.6.1	Controller and Memory Section	4.2-5
4.2.6.1.1	Patriot IC (U800).....	4.2-5
4.2.6.1.2	SRAM (U804)	4.2-8
4.2.6.1.3	Flash Memory (U803).....	4.2-9
4.2.6.2	Audio and Power Section	4.2-10

4.2.6.2.1 MAKO IC (U701).....	4.2-10
4.2.6.2.2 Regulator	4.2-11
4.2.6.2.3 Audio Pre-Amplifier	4.2-11
4.2.6.2.4 Audio Power Amplifier.....	4.2-11
4.2.6.3 Interface Support Section	4.2-12
4.2.6.3.1 MAKO IC U701	4.2-12
4.2.6.3.2 ESD Protection Circuitry	4.2-13
4.2.6.3.3 Universal Connector (Side Connector) Interface Circuitry	4.2-13
4.2.6.3.4 The Option Board.....	4.2-15
4.2.6.3.5 Encryption Module	4.2-16
4.2.6.3.6 System Clocks	4.2-17
4.2.6.4 Transmit Audio Path	4.2-17
4.2.6.5 Receive Audio Path	4.2-18

Chapter 4.3 UHF2 Detailed Theories of Operation 4.3-1

4.3.1 Introduction.....	4.3-1
4.3.2 Frequency Synthesis	4.3-1
4.3.3 Antenna Switch.....	4.3-2
4.3.4 Receiver	4.3-3
4.3.4.1 Front End	4.3-3
4.3.4.2 Back End.....	4.3-4
4.3.5 Transmitter	4.3-4
4.3.6 VOCON Functional Blocks	4.3-5
4.3.6.1 Controller and Memory Section	4.3-5
4.3.6.1.1 Patriot IC (U800).....	4.3-5
4.3.6.1.2 SRAM (U804).....	4.3-8
4.3.6.1.3 Flash Memory (U803)	4.3-8
4.3.6.2 Audio and Power Section.....	4.3-10
4.3.6.2.1 MAKO IC (U701).....	4.3-10
4.3.6.2.2 Regulator	4.3-11
4.3.6.2.3 Audio Pre-Amplifier	4.3-11
4.3.6.2.4 Audio Power Amplifier.....	4.3-11
4.3.6.3 Interface Support Section	4.3-12
4.3.6.3.1 MAKO IC U701	4.3-12
4.3.6.3.2 ESD Protection Circuitry	4.3-13
4.3.6.3.3 Universal Connector (Side Connector) Interface Circuitry	4.3-13
4.3.6.3.4 The Option Board.....	4.3-15
4.3.6.3.5 Encryption Module	4.3-16
4.3.6.3.6 System Clocks	4.3-17
4.3.6.4 Transmit Audio Path	4.3-17
4.3.6.5 Receive Audio Path	4.3-18

Chapter 4.4 700/800 MHz Detailed Theories of Operation 4.4-1

4.4.1 Introduction.....	4.4-1
4.4.2 Frequency Synthesis	4.4-1
4.4.3 Antenna Switch.....	4.4-2
4.4.4 Receiver	4.4-3
4.4.4.1 Front End	4.4-3
4.4.4.2 Back End.....	4.4-4
4.4.5 Transmitter	4.4-4

4.4.6	VOCON Functional Blocks	4.4-5
4.4.6.1	Controller and Memory Section	4.4-5
4.4.6.1.1	Patriot IC (U800).....	4.4-5
4.4.6.1.2	SRAM (U804)	4.4-8
4.4.6.1.3	Flash Memory (U803).....	4.4-8
4.4.6.2	Audio and Power Section	4.4-10
4.4.6.2.1	MAKO IC (U701).....	4.4-10
4.4.6.2.2	Regulator	4.4-11
4.4.6.2.3	Audio Pre-Amplifier	4.4-11
4.4.6.2.4	Audio Power Amplifier	4.4-11
4.4.6.3	Interface Support Section	4.4-12
4.4.6.3.1	MAKO IC U701	4.4-12
4.4.6.3.2	ESD Protection Circuitry	4.4-13
4.4.6.3.3	Universal Connector (Side Connector) Interface Circuitry	4.4-13
4.4.6.3.4	The Option Board	4.4-15
4.4.6.3.5	Encryption Module	4.4-16
4.4.6.3.6	System Clocks	4.4-17
4.4.6.4	Transmit Audio Path	4.4-17
4.4.6.5	Receive Audio Path	4.4-18

Chapter 4.5 900 MHz Detailed Theories of Operation 4.5-1

4.5.1	Introduction.....	4.5-1
4.5.2	Frequency Synthesis.....	4.5-1
4.5.3	Antenna Switch	4.5-2
4.5.4	Receiver	4.5-3
4.5.4.1	Front End	4.5-3
4.5.4.2	Back End	4.5-4
4.5.5	Transmitter	4.5-4
4.5.6	VOCON Functional Blocks	4.5-5
4.5.6.1	Controller and Memory Section	4.5-5
4.5.6.1.1	Patriot IC (U800).....	4.5-5
4.5.6.1.2	SRAM (U804)	4.5-8
4.5.6.1.3	Flash Memory (U803).....	4.5-8
4.5.6.2	Audio and Power Section	4.5-10
4.5.6.2.1	MAKO IC (U701).....	4.5-10
4.5.6.2.2	Regulator	4.5-11
4.5.6.2.3	Audio Pre-Amplifier	4.5-11
4.5.6.2.4	Audio Power Amplifier	4.5-11
4.5.6.3	Interface Support Section	4.5-11
4.5.6.3.1	MAKO IC U701	4.5-12
4.5.6.3.2	ESD Protection Circuitry	4.5-13
4.5.6.3.3	Universal Connector (Side Connector) Interface Circuitry	4.5-13
4.5.6.3.4	The Option Board	4.5-14
4.5.6.3.5	Encryption Module	4.5-16
4.5.6.3.6	System Clocks	4.5-17
4.5.6.4	Transmit Audio Path	4.5-17
4.5.6.5	Receive Audio Path	4.5-18

Chapter 5 Troubleshooting Procedures 5-1

5.1	Introduction.....	5-1
5.2	Handling Precautions	5-1
5.3	Voltage Measurement and Signal Tracing	5-1
5.4	Standard Bias Table	5-2
5.5	Power-Up Self-Check Errors	5-3
5.6	Operational Error Codes.....	5-4
5.6.1	Power-Up, Self-Check Diagnostics, and Repair (Not for Field Use).....	5-4

Chapter 6.1 VHF Troubleshooting Charts 6.1-1

6.1.1	Introduction.....	6.1-1
6.1.2	List of Troubleshooting Flowcharts.....	6.1-1
6.1.3	VHF Radio Main Troubleshooting Chart.....	6.1-2
6.1.4	Radio Power-Up Fail Troubleshooting Chart (1 of 3)	6.1-3
6.1.5	Radio Power-Up Fail Troubleshooting Chart (2 of 3)	6.1-4
6.1.6	Radio Power-Up Fail Troubleshooting Chart (3 of 3)	6.1-5
6.1.7	DC Supply Fail Troubleshooting Chart (1 of 3).....	6.1-6
6.1.8	DC Supply Fail Troubleshooting Chart (2 of 3).....	6.1-7
6.1.9	DC Supply Fail Troubleshooting Chart (3 of 3).....	6.1-8
6.1.10	Button Test Troubleshooting Chart.....	6.1-9
6.1.11	Volume Set Error Troubleshooting Chart	6.1-10
6.1.12	Zone/Channel Select Error Troubleshooting Chart	6.1-11
6.1.13	Top/Side Button Error Troubleshooting Chart	6.1-12
6.1.14	No Display Troubleshooting Chart (1 of 3)	6.1-13
6.1.15	No Display Troubleshooting Chart (2 of 3)	6.1-14
6.1.16	No Display Troubleshooting Chart (3 of 3)	6.1-15
6.1.17	VHF Receive RF Troubleshooting Chart.....	6.1-16
6.1.18	VOCON Receive Audio Troubleshooting Chart.....	6.1-17
6.1.19	VHF Frequency Generation Unit Troubleshooting Chart.....	6.1-18
6.1.20	VOCON Transmit Audio Troubleshooting Chart (1 of 2)	6.1-19
6.1.21	VOCON Transmit Audio Troubleshooting Chart (2 of 2)	6.1-20
6.1.22	No Transmit Deviation Troubleshooting Chart	6.1-21
6.1.23	VHF Transmitter RF Troubleshooting Chart.....	6.1-22
6.1.24	Secure Hardware Failure.....	6.1-23

Chapter 6.2 UHF1 Troubleshooting Charts 6.2-1

6.2.1	Introduction.....	6.2-1
6.2.2	List of Troubleshooting Flowcharts.....	6.2-1
6.2.3	UHF Range 1 Radio Main Troubleshooting Chart.....	6.2-2
6.2.4	Radio Power-Up Fail Troubleshooting Chart (1 of 3)	6.2-3
6.2.5	Radio Power-Up Fail Troubleshooting Chart (2 of 3)	6.2-4
6.2.6	Radio Power-Up Fail Troubleshooting Chart (3 of 3)	6.2-5
6.2.7	DC Supply Fail Troubleshooting Chart (1 of 3).....	6.2-6
6.2.8	DC Supply Fail Troubleshooting Chart (2 of 3).....	6.2-7
6.2.9	DC Supply Fail Troubleshooting Chart (3 of 3).....	6.2-8
6.2.10	Button Test Troubleshooting Chart.....	6.2-9
6.2.11	Volume Set Error Troubleshooting Chart	6.2-10
6.2.12	Zone/Channel Select Error Troubleshooting Chart	6.2-11
6.2.13	Top/Side Button Error Troubleshooting Chart	6.2-12

6.2.14 No Display Troubleshooting Chart (1 of 3)	6.2-13
6.2.15 No Display Troubleshooting Chart (2 of 3)	6.2-14
6.2.16 No Display Troubleshooting Chart (3 of 3)	6.2-15
6.2.17 UHF Range 1 Receive RF Troubleshooting Chart	6.2-16
6.2.18 VOCON Receive Audio Troubleshooting Chart	6.2-17
6.2.19 UHF Range 1 Frequency Generation Unit Troubleshooting Chart.....	6.2-18
6.2.20 VOCON Transmit Audio Troubleshooting Chart (1 of 2)	6.2-19
6.2.21 VOCON Transmit Audio Troubleshooting Chart (2 of 2)	6.2-20
6.2.22 No Transmit Deviation Troubleshooting Chart	6.2-21
6.2.23 UHF Range 1 Transmitter RF Troubleshooting Chart.....	6.2-22
6.2.24 Secure Hardware Failure	6.2-23

Chapter 6.3 UHF2 Troubleshooting Charts 6.3-1

6.3.1 Introduction.....	6.3-1
6.3.2 List of Troubleshooting Flowcharts.....	6.3-1
6.3.3 UHF Range 2 Radio Main Troubleshooting Chart.....	6.3-2
6.3.4 Radio Power-Up Fail Troubleshooting Chart (1 of 3)	6.3-3
6.3.5 Radio Power-Up Fail Troubleshooting Chart (2 of 3)	6.3-4
6.3.6 Radio Power-Up Fail Troubleshooting Chart (3 of 3)	6.3-5
6.3.7 DC Supply Fail Troubleshooting Chart (1 of 3)	6.3-6
6.3.8 DC Supply Fail Troubleshooting Chart (2 of 3)	6.3-7
6.3.9 DC Supply Fail Troubleshooting Chart (3 of 3)	6.3-8
6.3.10 Button Test Troubleshooting Chart	6.3-9
6.3.11 Volume Set Error Troubleshooting Chart	6.3-10
6.3.12 Zone/Channel Select Error Troubleshooting Chart	6.3-11
6.3.13 Top/Side Button Error Troubleshooting Chart	6.3-12
6.3.14 No Display Troubleshooting Chart (1 of 3)	6.3-13
6.3.15 No Display Troubleshooting Chart (2 of 3)	6.3-14
6.3.16 No Display Troubleshooting Chart (3 of 3)	6.3-15
6.3.17 UHF Range 2 Receive RF Troubleshooting Chart	6.3-16
6.3.18 VOCON Receive Audio Troubleshooting Chart	6.3-17
6.3.19 UHF Range 2 Frequency Generation Unit Troubleshooting Chart.....	6.3-18
6.3.20 VOCON Transmit Audio Troubleshooting Chart (1 of 2)	6.3-19
6.3.21 VOCON Transmit Audio Troubleshooting Chart (2 of 2)	6.3-20
6.3.22 No Transmit Deviation Troubleshooting Chart	6.3-21
6.3.23 UHF Range 2 Transmitter RF Troubleshooting Chart.....	6.3-22
6.3.24 Secure Hardware Failure	6.3-23

Chapter 6.4 700/800 MHz Troubleshooting Charts 6.4-1

6.4.1 Introduction.....	6.4-1
6.4.2 List of Troubleshooting Flowcharts.....	6.4-1
6.4.3 700/800 MHz Radio Main Troubleshooting Chart	6.4-2
6.4.4 Radio Power-Up Fail Troubleshooting Chart (1 of 3)	6.4-3
6.4.5 Radio Power-Up Fail Troubleshooting Chart (2 of 3)	6.4-4
6.4.6 Radio Power-Up Fail Troubleshooting Chart (3 of 3)	6.4-5
6.4.7 DC Supply Fail Troubleshooting Chart (1 of 3)	6.4-6
6.4.8 DC Supply Fail Troubleshooting Chart (2 of 3)	6.4-7
6.4.9 DC Supply Fail Troubleshooting Chart (3 of 3)	6.4-8
6.4.10 Button Test Troubleshooting Chart	6.4-9
6.4.11 Volume Set Error Troubleshooting Chart	6.4-10

6.4.12 Zone/Channel Select Error Troubleshooting Chart	6.4-11
6.4.13 Top/Side Button Error Troubleshooting Chart	6.4-12
6.4.14 No Display Troubleshooting Chart (1 of 3)	6.4-13
6.4.15 No Display Troubleshooting Chart (2 of 3)	6.4-14
6.4.16 No Display Troubleshooting Chart (3 of 3)	6.4-15
6.4.17 700/800 MHz Receive RF Troubleshooting Chart.....	6.4-16
6.4.18 VOCON Receive Audio Troubleshooting Chart.....	6.4-17
6.4.19 700/800 MHz Frequency Generation Unit Troubleshooting Chart	6.4-18
6.4.20 VOCON Transmit Audio Troubleshooting Chart (1 of 2)	6.4-19
6.4.21 VOCON Transmit Audio Troubleshooting Chart (2 of 2)	6.4-20
6.4.22 No Transmit Deviation Troubleshooting Chart	6.4-21
6.4.23 700/800 MHz Transmitter RF Troubleshooting Chart.....	6.4-22
6.4.24 Secure Hardware Failure.....	6.4-23

Chapter 6.5 900 MHz Troubleshooting Charts 6.5-1

6.5.1 Introduction.....	6.5-1
6.5.2 List of Troubleshooting Flowcharts.....	6.5-1
6.5.3 900 MHz Radio Main Troubleshooting Chart	6.5-2
6.5.4 Radio Power-Up Fail Troubleshooting Chart (1 of 3)	6.5-3
6.5.5 Radio Power-Up Fail Troubleshooting Chart (2 of 3)	6.5-4
6.5.6 Radio Power-Up Fail Troubleshooting Chart (3 of 3)	6.5-5
6.5.7 DC Supply Fail Troubleshooting Chart (1 of 3).....	6.5-6
6.5.8 DC Supply Fail Troubleshooting Chart (2 of 3).....	6.5-7
6.5.9 DC Supply Fail Troubleshooting Chart (3 of 3).....	6.5-8
6.5.10 Button Test Troubleshooting Chart.....	6.5-9
6.5.11 Volume Set Error Troubleshooting Chart	6.5-10
6.5.12 Zone/Channel Select Error Troubleshooting Chart	6.5-11
6.5.13 Top/Side Button Error Troubleshooting Chart	6.5-12
6.5.14 No Display Troubleshooting Chart (1 of 3)	6.5-13
6.5.15 No Display Troubleshooting Chart (2 of 3)	6.5-14
6.5.16 No Display Troubleshooting Chart (3 of 3)	6.5-15
6.5.17 900 MHz Receive RF Troubleshooting Chart.....	6.5-16
6.5.18 VOCON Receive Audio Troubleshooting Chart.....	6.5-17
6.5.19 900 MHz Frequency Generation Unit Troubleshooting Chart	6.5-18
6.5.20 VOCON Transmit Audio Troubleshooting Chart (1 of 2)	6.5-19
6.5.21 VOCON Transmit Audio Troubleshooting Chart (2 of 2)	6.5-20
6.5.22 No Transmit Deviation Troubleshooting Chart	6.5-21
6.5.23 900MHz Transmitter RF Troubleshooting Chart.....	6.5-22
6.5.24 Secure Hardware Failure.....	6.5-23

Chapter 7.1 VHF Troubleshooting Waveforms 7.1-1

7.1.1 Introduction.....	7.1-1
7.1.2 List of Waveforms.....	7.1-1
7.1.3 RF Test Points.....	7.1-2
7.1.4 Main Circuit Board RF Shield Locations.....	7.1-4
7.1.5 PP1 Antenna Input	7.1-6
7.1.6 PP2 TX Signal at Harmonic Filter Input.....	7.1-7
7.1.7 PP3 Coupler RF Out.....	7.1-8
7.1.8 PP4 TX Signal at PA	7.1-9
7.1.9 TP5 Coupler RF Feedback to PCIC	7.1-10

7.1.10 TP6 PCIC Control Voltage	7.1-11
7.1.11 PP7 TX LO	7.1-12
7.1.12 PP8 Higher Level Voltage Multiplier	7.1-13
7.1.13 PP9 Superfilter Output	7.1-14
7.1.14 PP11 Prescaler Input to FracN Synthesizer	7.1-15
7.1.15 PP12 Reference Crystal Output	7.1-16
7.1.16 TP13 Mod In	7.1-17
7.1.17 TP14 1st LO Control Voltage	7.1-18
7.1.18 PP15 VCO Output	7.1-19
7.1.19 PP17 Frequency Out (16.8 MHz)	7.1-20
7.1.20 PP18 RX RF Input at Antenna Switch	7.1-21
7.1.21 PP19 Antenna Switch Bias	7.1-22
7.1.22 PP20 Preselector Tuning Voltage	7.1-23
7.1.23 PP22 Analog 5V	7.1-24
7.1.24 PP23 Preselector 1 Output	7.1-25
7.1.25 PP24 Low-Noise Amplifier Output	7.1-26
7.1.26 PP25 Preselector 2 Output	7.1-27
7.1.27 PP26 Mixer Out (IF)	7.1-28
7.1.28 PP27 Crystal Filter Out	7.1-29
7.1.29 PP28 Abacus Analog 3V	7.1-30
7.1.30 PP29 2nd LO Control Voltage	7.1-31
7.1.31 PP30 2nd LO VCO Buffer Output	7.1-32
7.1.32 PP31 Analog 5V DC	7.1-33
7.1.33 PP32 Abacus Digital 3V	7.1-34
7.1.34 TX Audio 1 kHz Tone	7.1-35
7.1.35 16.8 MHz Buffer Input and Output	7.1-36
7.1.36 32.768 kHz Clock Outputs	7.1-37
7.1.37 SPI B Data	7.1-38
7.1.38 RX Serial Audio Port (SAP)	7.1-39
7.1.39 PP33 SPI Data	7.1-40
7.1.40 PP34 SPI CLK	7.1-41
7.1.41 PP35 Universal Chip Select	7.1-42
7.1.42 PP36 Abacus Chip Select	7.1-43
7.1.43 TP37 RX SSI Data	7.1-44
7.1.44 TP38 RX SSI Clock	7.1-45
7.1.45 TP39 RX SSI Frame Sync	7.1-46

Chapter 7.2 UHF1 Troubleshooting Waveforms 7.2-1

7.2.1 Introduction	7.2-1
7.2.2 List of Waveforms	7.2-1
7.2.3 RF Test Points	7.2-2
7.2.4 Main Circuit Board RF Shield Locations	7.2-4
7.2.5 PP1 Antenna Input	7.2-6
7.2.6 PP2 TX Signal at Harmonic Filter Input	7.2-7
7.2.7 PP3 Coupler RF Out	7.2-8
7.2.8 PP4 TX Signal at PA	7.2-9
7.2.9 TP5 Coupler RF Feedback to PCIC	7.2-10
7.2.10 TP6 PCIC Control Voltage	7.2-11
7.2.11 PP7 TX LO	7.2-12
7.2.12 PP8 Higher Level Voltage Multiplier	7.2-13
7.2.13 PP9 Superfilter Output	7.2-14
7.2.14 PP11 Prescaler Input to FracN Synthesizer	7.2-15

7.2.15 PP12 Reference Crystal Output	7.2-16
7.2.16 TP13 Mod In	7.2-17
7.2.17 TP14 1st LO Control Voltage.....	7.2-18
7.2.18 PP15 VCO Output	7.2-19
7.2.19 PP17 Frequency Out (19.2 MHz)	7.2-21
7.2.20 PP18 RX RF Input at Antenna Switch	7.2-22
7.2.21 PP19 Antenna Switch Bias	7.2-23
7.2.22 PP20 Preselector Tuning Voltage	7.2-24
7.2.23 PP22 Analog 5V	7.2-25
7.2.24 PP23 Preselector 1 Output.....	7.2-26
7.2.25 PP24 Low-Noise Amplifier Output	7.2-27
7.2.26 PP25 Preselector 2 Output.....	7.2-28
7.2.27 PP26 Mixer Out (IF).....	7.2-29
7.2.28 PP27 Crystal Filter Out.....	7.2-30
7.2.29 PP28 Abacus Analog 3V	7.2-31
7.2.30 PP29 2nd LO Control Voltage	7.2-32
7.2.31 PP30 2nd LO VCO Buffer Output.....	7.2-33
7.2.32 PP31 Analog 5V DC	7.2-34
7.2.33 PP32 Abacus Digital 3V	7.2-35
7.2.34 TX Audio 1 kHz Tone	7.2-36
7.2.35 16.8 MHz Buffer Input and Output.....	7.2-37
7.2.36 32.768 kHz Clock Outputs	7.2-38
7.2.37 SPI B Data.....	7.2-39
7.2.38 RX Serial Audio Port (SAP)	7.2-40
7.2.39 PP33 SPI Data	7.2-41
7.2.40 PP34 SPI CLK.....	7.2-42
7.2.41 PP35 Universal Chip Select	7.2-43
7.2.42 PP36 Abacus Chip Select	7.2-44
7.2.43 TP37 RX SSI Data.....	7.2-45
7.2.44 TP38 RX SSI Clock	7.2-46
7.2.45 TP39 RX SSI Frame Sync.....	7.2-47

Chapter 7.3 UHF2 Troubleshooting Waveforms 7.3-1

7.3.1 Introduction.....	7.3-1
7.3.2 List of Waveforms.....	7.3-1
7.3.3 RF Test Points.....	7.3-2
7.3.4 Main Circuit Board RF Shield Locations	7.3-4
7.3.5 PP1 Antenna Input	7.3-6
7.3.6 PP2 TX Signal at Harmonic Filter Input.....	7.3-7
7.3.7 PP3 Coupler RF Out.....	7.3-8
7.3.8 PP4 TX Signal at PA	7.3-9
7.3.9 TP5 Coupler RF Feedback to PCIC	7.3-10
7.3.10 TP6 PCIC Control Voltage.....	7.3-11
7.3.11 PP7 TX LO	7.3-12
7.3.12 PP8 Higher Level Voltage Multiplier	7.3-13
7.3.13 PP9 Superfilter Output.....	7.3-14
7.3.14 PP11 Prescaler Input to FracN Synthesizer	7.3-15
7.3.15 PP12 Reference Crystal Output	7.3-16
7.3.16 TP13 Mod In	7.3-17
7.3.17 TP14 1st LO Control Voltage.....	7.3-18
7.3.18 PP15 VCO Output	7.3-19
7.3.19 PP17 Frequency Out (19.2 MHz)	7.3-20

7.3.20 PP18 RX RF Input at Antenna Switch.....	7.3-21
7.3.21 PP19 Antenna Switch Bias.....	7.3-22
7.3.22 PP20 Preselector Tuning Voltage.....	7.3-23
7.3.23 PP22 Analog 5V.....	7.3-24
7.3.24 PP23 Preselector 1 Output.....	7.3-25
7.3.25 PP24 Low-Noise Amplifier Output.....	7.3-26
7.3.26 PP25 Preselector 2 Output.....	7.3-27
7.3.27 PP26 Mixer Out (IF).....	7.3-28
7.3.28 PP27 Crystal Filter Out.....	7.3-29
7.3.29 PP28 Abacus Analog 3V.....	7.3-30
7.3.30 PP29 2nd LO Control Voltage.....	7.3-31
7.3.31 PP30 2nd LO VCO Buffer Output.....	7.3-32
7.3.32 PP31 Analog 5V DC.....	7.3-33
7.3.33 PP32 Abacus Digital 3V.....	7.3-34
7.3.34 TX Audio 1 kHz Tone.....	7.3-35
7.3.35 16.8 MHz Buffer Input and Output.....	7.3-36
7.3.36 32.768 kHz Clock Outputs.....	7.3-37
7.3.37 SPI B Data.....	7.3-38
7.3.38 RX Serial Audio Port (SAP).....	7.3-39
7.3.39 PP33 SPI Data.....	7.3-40
7.3.40 PP34 SPI CLK.....	7.3-41
7.3.41 PP35 Universal Chip Select.....	7.3-42
7.3.42 PP36 Abacus Chip Select.....	7.3-43
7.3.43 TP37 RX SSI Data.....	7.3-44
7.3.44 TP38 RX SSI Clock.....	7.3-45
7.3.45 TP39 RX SSI Frame Sync.....	7.3-46

Chapter 7.4.4 700/800 MHz Troubleshooting Waveforms 7.4-1

7.4.1 Introduction.....	7.4-1
7.4.2 List of Waveforms.....	7.4-1
7.4.3 RF Test Points.....	7.4-2
7.4.4 Main Circuit Board RF Shield Locations.....	7.4-4
7.4.5 PP1 Antenna Input.....	7.4-6
7.4.6 PP2 TX Signal at Harmonic Filter Input.....	7.4-7
7.4.7 PP3 Coupler RF Out.....	7.4-8
7.4.8 PP4 TX Signal at PA.....	7.4-9
7.4.9 TP5 Coupler RF Feedback to PCIC.....	7.4-10
7.4.10 TP6 PCIC Control Voltage.....	7.4-11
7.4.11 PP7 TX LO.....	7.4-12
7.4.12 PP8 Higher Level Voltage Multiplier.....	7.4-13
7.4.13 PP9 Superfilter Output.....	7.4-14
7.4.14 TP10 TRB.....	7.4-15
7.4.15 PP11 Prescaler Input to FracN Synthesizer.....	7.4-16
7.4.16 PP12 Reference Crystal Output.....	7.4-17
7.4.17 TP13 Mod In.....	7.4-18
7.4.18 TP14 1st LO Control Voltage.....	7.4-19
7.4.19 PP15 VCO Output.....	7.4-20
7.4.20 PP16 VCO RX LO.....	7.4-21
7.4.21 PP17 Frequency Out (16.8 MHz).....	7.4-22
7.4.22 PP18 RX RF Input at Antenna Switch.....	7.4-23
7.4.23 PP19 Antenna Switch Bias.....	7.4-24
7.4.24 PP20 Preselector Tuning Voltage.....	7.4-25

7.4.25 PP21 RX RF Input after Antenna Switch.....	7.4-26
7.4.26 PP22 Analog 5V	7.4-27
7.4.27 PP23 Preselector 1 Output.....	7.4-28
7.4.28 PP24 Low-Noise Amplifier Output.....	7.4-29
7.4.29 PP25 Preselector 2 Output.....	7.4-30
7.4.30 PP26 Mixer Out (IF).....	7.4-31
7.4.31 PP27 Crystal Filter Out.....	7.4-32
7.4.32 PP28 Abacus Analog 3V	7.4-33
7.4.33 PP29 2nd LO Control Voltage	7.4-34
7.4.34 PP30 2nd LO VCO Buffer Output.....	7.4-35
7.4.35 PP31 Analog 5V DC	7.4-36
7.4.36 PP32 Abacus Digital 3V	7.4-37
7.4.37 TX Audio 1 kHz Tone	7.4-38
7.4.38 16.8 MHz Buffer Input and Output.....	7.4-39
7.4.39 32.768 kHz Clock Outputs.....	7.4-40
7.4.40 SPI B Data.....	7.4-41
7.4.41 RX Serial Audio Port (SAP).....	7.4-42
7.4.42 PP33 SPI Data	7.4-43
7.4.43 PP34 SPI CLK.....	7.4-44
7.4.44 PP35 Universal Chip Select	7.4-45
7.4.45 PP36 Abacus Chip Select	7.4-46
7.4.46 TP37 RX SSI Data.....	7.4-47
7.4.47 TP38 RX SSI Clock	7.4-48
7.4.48 TP39 RX SSI Frame Sync.....	7.4-49
7.4.49 TP40 RX SSI Sync B.....	7.4-50

Chapter 7.5 Troubleshooting Waveforms 7.5-1

7.5.1 Introduction.....	7.5-1
7.5.2 List of Waveforms.....	7.5-1
7.5.3 RF Test Points.....	7.5-2
7.5.4 Main Circuit Board RF Shield Locations.....	7.5-4
7.5.5 PP1 Antenna Input	7.5-6
7.5.6 PP2 TX Signal at Harmonic Filter Input.....	7.5-7
7.5.7 PP3 Coupler RF Out.....	7.5-8
7.5.8 PP4 TX Signal at PA	7.5-9
7.5.9 TP5 Coupler RF Feedback to PCIC	7.5-10
7.5.10 TP6 PCIC Control Voltage.....	7.5-11
7.5.11 PP7 TX LO	7.5-12
7.5.12 PP8 Higher Level Voltage Multiplier	7.5-13
7.5.13 PP9 Superfilter Output.....	7.5-14
7.5.14 TP10 TRB.....	7.5-15
7.5.15 PP11 Prescaler Input to FracN Synthesizer	7.5-16
7.5.16 PP12 Reference Crystal Output	7.5-17
7.5.17 TP13 Mod In.....	7.5-18
7.5.18 TP14 1st LO Control Voltage.....	7.5-19
7.5.19 PP15 VCO Output	7.5-20
7.5.20 PP16 VCO RX LO	7.5-21
7.5.21 PP17 Frequency Out (16.8 MHz)	7.5-22
7.5.22 PP18 RX RF Input at Antenna Switch.....	7.5-23
7.5.23 PP19 Antenna Switch Bias.....	7.5-24
7.5.24 PP20 Preselector Tuning Voltage	7.5-25
7.5.25 PP21 RX RF Input after Antenna Switch.....	7.5-26

7.5.26 PP22 Analog 5V	7.5-27
7.5.27 PP23 Preselector 1 Output.....	7.5-28
7.5.28 PP24 Low-Noise Amplifier Output.....	7.5-29
7.5.29 PP25 Preselector 2 Output.....	7.5-30
7.5.30 PP26 Mixer Out (IF)	7.5-31
7.5.31 PP27 Crystal Filter Out.....	7.5-32
7.5.32 PP28 Abacus Analog 3V	7.5-33
7.5.33 PP29 2nd LO Control Voltage	7.5-34
7.5.34 PP30 2nd LO VCO Buffer Output.....	7.5-35
7.5.35 PP31 Analog 5V DC.....	7.5-36
7.5.36 PP32 Abacus Digital 3V	7.5-37
7.5.37 TX Audio 1 kHz Tone	7.5-38
7.5.38 16.8 MHz Buffer Input and Output.....	7.5-39
7.5.39 32.768 kHz Clock Outputs.....	7.5-40
7.5.40 SPI B Data.....	7.5-41
7.5.41 RX Serial Audio Port (SAP).....	7.5-42
7.5.42 PP33 SPI Data	7.5-43
7.5.43 PP34 SPI CLK.....	7.5-44
7.5.44 PP35 Universal Chip Select	7.5-45
7.5.45 PP36 Abacus Chip Select	7.5-46
7.5.46 TP37 RX SSI Data	7.5-47
7.5.47 TP38 RX SSI Clock.....	7.5-48
7.5.48 TP39 RX SSI Frame Sync.....	7.5-49
7.5.49 TP40 RX SSI Sync B.....	7.5-50
Chapter 8.1 VHF Troubleshooting Tables	8.1-1
8.1.1 Introduction.....	8.1-1
8.1.2 Tables.....	8.1-1
Chapter 8.2 UHF1 Troubleshooting Tables	8.2-1
8.2.1 Introduction.....	8.2-1
8.2.2 Tables.....	8.2-1
Chapter 8.3 UHF2 Troubleshooting Tables	8.3-1
8.3.1 Introduction.....	8.3-1
8.3.2 Tables.....	8.3-1
Chapter 8.4 700/800 MHz Troubleshooting Tables	8.4-1
8.4.1 Introduction.....	8.4-1
8.4.2 Tables.....	8.4-1
Chapter 8.5 900MHz Troubleshooting Tables	8.5-1
8.5.1 Introduction.....	8.5-1
8.5.2 Tables.....	8.5-1

Chapter 9.1	VHF Schematics, Board Overlays, and Parts Lists.....	9.1-1
9.1.1	Introduction	9.1-1
Chapter 9.2	UHF1 Schematics, Board Overlays, and Parts Lists	9.2-1
9.2.1	Introduction	9.2-1
Chapter 9.3	UHF2 Schematics, Board Overlays, and Parts Lists	9.3-1
9.3.1	Introduction	9.3-1
Chapter 9.4	700/800 MHz Schematics, Board Overlays, and Parts Lists .	9.4-1
9.4.1	Introduction	9.4-1
Chapter 9.5	900MHz Schematics, Board Overlays, and Parts Lists	9.5-1
9.5.1	Introduction	9.5-1
Appendix A	Replacement Parts Ordering.....	A-1
A.1	Basic Ordering Information.....	A-1
A.2	Radio Board Ordering Information.....	A-1
A.3	Motorola Online	A-1
A.4	Mail Orders	A-1
A.5	Telephone Orders.....	A-2
A.6	Fax Orders.....	A-2
A.7	Parts Identification	A-2
A.8	Product Customer Service.....	A-2
Glossary	Glossary-1	
Index	Index-1	

List of Figures

Figure 3.1-1.B+ Routing for VHF Main Board	3.1-2
Figure 3.1-2.XTS 2500/XTS 2500I DC Distribution (for all other kits)	3.1-3
Figure 3.2-1.B+ Routing for Main Board	3.2-2
Figure 3.2-2.XTS 2500/XTS 2500I DC Distribution (for all other kits)	3.2-3
Figure 3.3-1.B+ Routing for Main Board	3.3-2
Figure 3.3-2.XTS 2500/XTS 2500I DC Distribution (for all other kits)	3.3-3
Figure 3.4-1.B+ Routing for 700/800 MHz Main Board	3.4-2
Figure 3.4-2.XTS 2500/XTS 2500I DC Distribution (for all other kits)	3.4-3
Figure 3.5-1.B+ Routing for 900MHz Main Board	3.5-2
Figure 3.5-2.XTS 2500/XTS 2500I DC Distribution (for all other kits)	3.5-3
Figure 4.1-1.Controller Memory Interface	4.1-9
Figure 4.1-2.Universal (Side) Connector	4.1-14
Figure 4.1-3.VOCON Connector J650	4.1-14
Figure 4.1-4.VOCON Transmit Audio Path	4.1-17
Figure 4.1-5.VOCON Receive Audio Path	4.1-18
Figure 4.2-1.Controller Memory Interface	4.2-9
Figure 4.2-2.Universal (Side) Connector	4.2-14
Figure 4.2-3.VOCON Connector J650	4.2-14
Figure 4.2-4.VOCON Transmit Audio Path	4.2-17
Figure 4.2-5.VOCON Receive Audio Path	4.2-18
Figure 4.3-1.Controller Memory Interface	4.3-9
Figure 4.3-2.Universal (Side) Connector	4.3-14
Figure 4.3-3.VOCON Connector J650	4.3-14
Figure 4.3-4.VOCON Transmit Audio Path	4.3-17
Figure 4.3-5.VOCON Receive Audio Path	4.3-18
Figure 4.4-1.Controller Memory Interface	4.4-9
Figure 4.4-2.Universal (Side) Connector	4.4-14
Figure 4.4-3.VOCON Connector J650	4.4-14
Figure 4.4-4.VOCON Transmit Audio Path	4.4-18
Figure 4.4-5.VOCON Receive Audio Path	4.4-19
Figure 4.5-1.Controller Memory Interface	4.5-9
Figure 4.5-2.Universal (Side) Connector	4.5-14
Figure 4.5-3.VOCON Connector J650	4.5-14
Figure 4.5-4.VOCON Transmit Audio Path	4.5-17
Figure 4.5-5.VOCON Receive Audio Path	4.5-18
Figure 7.1-1.RF Block Diagram Test Points	7.1-2
Figure 7.2-1.RF Block Diagram Test Points	7.2-2
Figure 7.3-1.RF Block Diagram Test Points	7.3-2
Figure 7.4-1.RF Block Diagram Test Points	7.4-2
Figure 7.5-1.RF Block Diagram Test Points	7.5-2
Figure 9.1-1.Radio Interconnect Block Diagram	9.1-2
Figure 9.1-2.PMLD4303A/ PMLD4303D Top Level Schematic	9.1-3
Figure 9.1-3.PMLD4303A/ PMLD4303D Controller Interface Schematic.....	9.1-4
Figure 9.1-4.PMLD4303A/ PMLD4303D Interface and Accessories Schematic.....	9.1-5
Figure 9.1-5.PMLD4303A/ PMLD4303D Side Connector Schematic	9.1-6
Figure 9.1-6.PMLD4303A/ PMLD4303D Controller Schematic.....	9.1-7
Figure 9.1-7.PMLD4303A/ PMLD4303D Patriot Bravo (U800) Schematic	9.1-8
Figure 9.1-8.PMLD4303A/ PMLD4303D MAKO DC and Audio Schematic - Sheet 1 of 2.....	9.1-9
Figure 9.1-9.PMLD4303A/ PMLD4303D MAKO DC and Audio Schematic - Sheet 2 of 2.....	9.1-10
Figure 9.1-10.PMLD4303A/ PMLD4303D Memory Schematic	9.1-11

Figure 9.1-11.PMLD4303A/ PMLD4303D Frequency Generation Unit (FGU) and Digital to Analog Converter (DAC) Schematic	9.1-12
Figure 9.1-12.PMLD4303A Frequency Generation Unit (FGU) Schematic - Sheet 1 of 3	9.1-13
Figure 9.1-13.PMLD4303D Frequency Generation Unit (FGU) Schematic - Sheet 1 of 3	9.1-14
Figure 9.1-14.PMLD4303A/ PMLD4303D Frequency Generation Unit (FGU) Schematic - Sheet 2 of 3	9.1-15
Figure 9.1-15.PMLD4303A/ PMLD4303D Frequency Generation Unit (FGU) Schematic - Sheet 3 of 3	9.1-16
Figure 9.1-16.PMLD4303A/ PMLD4303D Receiver Front End and DC Schematic	9.1-17
Figure 9.1-17.PMLD4303A/ PMLD4303D Receiver Front End Schematic	9.1-18
Figure 9.1-18.PMLD4303A/ PMLD4303D Receiver Schematic - Sheet 1 of 4	9.1-19
Figure 9.1-19.PMLD4303A/ PMLD4303D Receiver Schematic - Sheet 2 of 4	9.1-20
Figure 9.1-20.PMLD4303A/ PMLD4303D Receiver Schematic - Sheet 3 of 4	9.1-21
Figure 9.1-21.PMLD4303A/ PMLD4303D Receiver Schematic (Regulators) - Sheet 4 of 4	9.1-22
Figure 9.1-22.PMLD4303A/ PMLD4303D RF Schematic.....	9.1-23
Figure 9.1-23.PMLD4303A/ PMLD4303D Transmitter Schematic	9.1-24
Figure 9.1-24.PMLD4303A RF Controls Schematic.....	9.1-25
Figure 9.1-25.PMLD4303D RF Controls Schematic.....	9.1-26
Figure 9.1-26.PMLD4303A/ PMLD4303D Main Circuit Board Component Location Detail - Side 1 ...	9.1-27
Figure 9.1-27.PMLD4303A/ PMLD4303D Main Circuit Board Component Location Detail - Side 2 ...	9.1-28
Figure 9.2-1.Radio Interconnect Block Diagram	9.2-2
Figure 9.2-2.PMLE2537A/ PMLE2537D Top Level Schematic	9.2-3
Figure 9.2-3.PMLE2537A/ PMLE2537D Controller Interface Schematic	9.2-4
Figure 9.2-4.PMLE2537A/ PMLE2537D Controller Schematic	9.2-5
Figure 9.2-5.PMLE2537A/ PMLE2537D Memory Schematic.....	9.2-6
Figure 9.2-6.PMLE2537A/ PMLE2537D Patriot Bravo (U800) Schematic	9.2-7
Figure 9.2-7.PMLE2537A/ PMLE2537D MAKO DC and Audio Schematic - Sheet 1 of 2	9.2-8
Figure 9.2-8.PMLE2537A/ PMLE2537D MAKO DC and Audio Schematic - Sheet 2 of 2	9.2-9
Figure 9.2-9.PMLE2537A/ PMLE2537D Interface and Accessories Schematic	9.2-10
Figure 9.2-10.PMLE2537A/ PMLE2537D Side Connector Schematic	9.2-11
Figure 9.2-11.PMLE2537A/ PMLE2537D RF Schematic	9.2-12
Figure 9.2-12.PMLE2537A/ PMLE2537D Receiver Front End and DC Schematic.....	9.2-13
Figure 9.2-13.PMLE2537A/ PMLE2537D Receiver Front End Schematic.....	9.2-14
Figure 9.2-14.PMLE2537A/ PMLE2537D Receiver Schematic - Sheet 1 of 4	9.2-15
Figure 9.2-15.PMLE2537A/ PMLE2537D Receiver Schematic - Sheet 2 of 4	9.2-16
Figure 9.2-16.PMLE2537A/ PMLE2537D Receiver Schematic - Sheet 3 of 4	9.2-17
Figure 9.2-17.PMLE2537A/ PMLE2537D Receiver Schematic, Regulators - Sheet 4 of 4	9.2-18
Figure 9.2-18.PMLE2537A/ PMLE2537D Frequency Generation Unit (FGU) and Digital to Analog Converter (DAC) Schematic	9.2-19
Figure 9.2-19.PMLE2537A Frequency Generation Unit (FGU) Schematic - Sheet 1 of 4	9.2-20
Figure 9.2-20.PMLE2537D Frequency Generation Unit (FGU) Schematic - Sheet 1 of 4	9.2-21
Figure 9.2-21.PMLE2537A/ PMLE2537D Frequency Generation Unit (FGU) Schematic - Sheet 2 of 4	9.2-22
Figure 9.2-22.PMLE2537A/ PMLE2537D Frequency Generation Unit (FGU) Schematic - Sheet 3 of 4	9.2-23
Figure 9.2-23.PMLE2537A/ PMLE2537D Frequency Generation Unit (FGU) Schematic - Sheet 4 of 4	9.2-24
Figure 9.2-24.PMLE2537A RF Controls Schematic	9.2-25
Figure 9.2-25.PMLE2537D RF Controls Schematic.....	9.2-26
Figure 9.2-26.PMLE2537A/ PMLE2537D Transmitter Schematic.....	9.2-27
Figure 9.2-27.PMLE2537A/ PMLE2537D Main Circuit Board Component Location Detail - Top Side	9.2-28
Figure 9.2-28.PMLE2537A/ PMLE2537D Main Circuit Board Component Location Detail - Bottom Side	9.2-29
Figure 9.3-1.PMLE4427A/ PMLE4427B (8416852H01_A)	9.3-2

Figure 9.3-2.PMLE4427A Controls	9.3-3
Figure 9.3-3.PMLE4427B Controls	9.3-4
Figure 9.3-4.PMLE4427A/ PMLE4427B Controller Interface Schematic	9.3-5
Figure 9.3-5.PMLE4427A/ PMLE4427B Patriot Bravo Revision Schematic	9.3-6
Figure 9.3-6.PMLE4427A/ PMLE4427B Digital to Analog Schematic.....	9.3-7
Figure 9.3-7.PMLE4427A/ PMLE4427B Frequency Generation Unit (FGU) Schematic.....	9.3-8
Figure 9.3-8.PMLE4427A/ PMLE4427B Interface and Accessories Schematic	9.3-9
Figure 9.3-9.PMLE4427A/ PMLE4427B LNA Schematic.....	9.3-10
Figure 9.3-10.PMLE4427A/ PMLE4427B MAKO Schematic - Sheet 1 of 2.....	9.3-11
Figure 9.3-11.PMLE4427A/ PMLE4427B MAKO Schematic - Sheet 2 of 2.....	9.3-12
Figure 9.3-12.PMLE4427A/ PMLE4427B Memory Schematic.....	9.3-13
Figure 9.3-13.PMLE4427A/ PMLE4427B Mixer Schematic	9.3-14
Figure 9.3-14.PMLE4427A/ PMLE4427B Patriot Schematic	9.3-15
Figure 9.3-15.PMLE4427A/ PMLE4427B Regulators Schematic	9.3-16
Figure 9.3-16.PMLE4427A/ PMLE4427B RF Schematic.....	9.3-17
Figure 9.3-17.PMLE4427A/ PMLE4427B RX Schematic.....	9.3-18
Figure 9.3-18.PMLE4427A/ PMLE4427B RX (back-end) Schematic.....	9.3-19
Figure 9.3-19.PMLE4427A/ PMLE4427B RX (front-end) Schematic	9.3-20
Figure 9.3-20.PMLE4427A/ PMLE4427B Side Connector Schematic	9.3-21
Figure 9.3-21.PMLE4427A Synthesizer Schematic	9.3-22
Figure 9.3-22.PMLE4427B Synthesizer Schematic	9.3-23
Figure 9.3-23.PMLE4427A/ PMLE4427B TX Schematic	9.3-24
Figure 9.3-24.PMLE4427A/ PMLE4427B VCO Schematic	9.3-25
Figure 9.3-25. 8416852H01_A Top Overlay	9.3-26
Figure 9.3-26.8416852H01_A Bottom Overlay	9.3-27
Figure 9.4-1.PMLF4040A/ PMLF4040B (8416095H01-A) Top Level Schematic.....	9.4-2
Figure 9.4-2.PMLF4040A/ PMLF4040B Controller Interface Schematic.....	9.4-3
Figure 9.4-1.PMLF4040A/ PMLF4040B Interface and Accessories Schematic.....	9.4-4
Figure 9.4-3.PMLF4040A/ PMLF4040B Side Connector Schematic	9.4-5
Figure 9.4-4.PMLF4040A/ PMLF4040B Controller Schematic.....	9.4-6
Figure 9.4-5.PMLF4040A/ PMLF4040B Patriot Bravo (U800) Schematic	9.4-7
Figure 9.4-6.PMLF4040A/ PMLF4040B MAKO DC and Audio Schematic - Sheet 1 of 2.....	9.4-8
Figure 9.4-7.PMLF4040A/ PMLF4040B MAKO DC and Audio Schematic - Sheet 2 of 2.....	9.4-9
Figure 9.4-8.PMLF4040A/ PMLF4040B Memory Schematic	9.4-10
Figure 9.4-9.PMLF4040A/ PMLF4040B Frequency Generation Unit (FGU) Schematic - Sheet 1 of 3	9.4-11
Figure 9.4-1.PMLF4040A/ PMLF4040B Frequency Generation Unit (FGU) Schematic - Sheet 2 of 3	9.4-12
Figure 9.4-10.PMLF4040A/ PMLF4040B Frequency Generation Unit (FGU) Schematic - Sheet 3 of 3	9.4-13
Figure 9.4-11.PMLF4040A/ PMLF4040B Receiver Schematic - Sheet 1 of 2	9.4-14
Figure 9.4-12.PMLF4040A/ PMLF4040B Receiver Schematic - Sheet 2 of 2	9.4-15
Figure 9.4-13.PMLF4040A/ PMLF4040B Transmitter Schematic.....	9.4-16
Figure 9.4-14.PMLF4040A/ PMLF4040B RF Schematic	9.4-17
Figure 9.4-15.PMLF4040A/ PMLF4040B (8416095H01-A) Main Circuit Board Component Location Detail - Side 1	9.4-18
Figure 9.4-16.PMLF4040A/ PMLF4040B (8416095H01-A) Main Circuit Board Component Location Detail - Side 2	9.4-19
Figure 9.5-1. Top Level Schematic (PCB No. 8416005H01)	9.5-2
Figure 9.5-2.Controller Interface Schematic.....	9.5-3
Figure 9.5-3.Interface and Accessories Schematic.....	9.5-4
Figure 9.5-4.Side Connector Schematic	9.5-5
Figure 9.5-5.Controller Schematic.....	9.5-6
Figure 9.5-6.Patriot Bravo (U800) Schematic	9.5-7

Figure 9.5-7.MAKO DC and Audio Schematic - Sheet 1 of 2.....	9.5-8
Figure 9.5-8.MAKO DC and Audio Schematic - Sheet 2 of 2.....	9.5-9
Figure 9.5-9.Memory Schematic	9.5-10
Figure 9.5-10.Frequency Generation Unit (FGU) Schematic - Sheet 1 of 3.....	9.5-11
Figure 9.5-11.Frequency Generation Unit (FGU) Schematic - Sheet 2 of 3.....	9.5-12
Figure 9.5-12.Frequency Generation Unit (FGU) Schematic - Sheet 3 of 3.....	9.5-13
Figure 9.5-13.Receiver Schematic - Sheet 1 of 2.....	9.5-14
Figure 9.5-14.Receiver Schematic - Sheet 2 of 2.....	9.5-15
Figure 9.5-15.Transmitter Schematic	9.5-16
Figure 9.5-16.Main Circuit Board Component Location Detail - Side 1 (PCB No. 8416005H01-A)	9.5-17
Figure 9.5-17.Main Circuit Board Component Location Detail - Side 2 (PCB No. 8416005H01-A)	9.5-18

List of Tables

Table 3.1-1. Power Supply Configuration for VOCON Section	3.1-4
Table 3.2-1. Power Supply Configuration for VOCON Section	3.2-4
Table 3.3-1. Power Supply Configuration for VOCON Section	3.3-4
Table 3.4-1. Power Supply Configuration for VOCON Section	3.4-4
Table 3.5-1. Power Supply Configuration for VOCON Section	3.5-4
Table 4.1-1. Option Select Functions	4.1-14
Table 4.1-2. Encryption Module Software Kits and Algorithms	4.1-16
Table 4.2-1. Option Select Functions	4.2-14
Table 4.2-2. Encryption Module Software Kits and Algorithms	4.2-16
Table 4.3-1. Option Select Functions	4.3-14
Table 4.3-2. Encryption Module Software Kits and Algorithms	4.3-16
Table 4.4-1. Option Select Functions	4.4-14
Table 4.4-2. Encryption Module Software Kits and Algorithms	4.4-16
Table 4.5-1. Option Select Functions	4.5-14
Table 4.5-2. Encryption Module Software Kits and Algorithms	4.5-16
Table 5-1. Standard Operating Bias	5-2
Table 5-2. Power-up Self-Check Error Codes	5-3
Table 5-3. Operational Error Code Displays	5-4
Table 5-4. Additional Error Code Action Items	5-4
Table 7.1-1. List of Waveforms	7.1-1
Table 7.1-2. RF Block Diagram Probe/Test Points	7.1-3
Table 7.1-3. Main Circuit Board Side 1 RF Shields	7.1-4
Table 7.1-4. Main Circuit Board Side 2 RF Shields	7.1-5
Table 7.2-1. List of Waveforms	7.2-1
Table 7.2-2. RF Block Diagram Probe/Test Points	7.2-3
Table 7.2-3. Main Circuit Board Side 1 RF Shields	7.2-4
Table 7.2-4. Main Circuit Board Side 2 RF Shields	7.2-5
Table 7.3-1. List of Waveforms	7.3-1
Table 7.3-2. RF Block Diagram Probe/Test Points	7.3-3
Table 7.3-3. Main Circuit Board Side 1 RF Shields	7.3-4
Table 7.3-4. Main Circuit Board Side 2 RF Shields	7.3-5
Table 7.4-1. List of Waveforms	7.4-1
Table 7.4-2. RF Block Diagram Probe/Test Points	7.4-3
Table 7.4-3. Main Circuit Board Side 1 RF Shields	7.4-4
Table 7.4-4. Main Circuit Board Side 2 RF Shields	7.4-5
Table 7.5-1. List of Waveforms	7.5-1
Table 7.5-2. RF Block Diagram Probe/Test Points	7.5-3
Table 7.5-3. Main Circuit Board Side 1 RF Shields	7.5-4
Table 7.5-4. Main Circuit Board Side 2 RF Shields	7.5-5
Table 8.1-1. Main Board to Keypad Board Flex Assembly (J601)	8.1-1
Table 8.1-2. Main Board to Universal (Side) Connector Flex Assembly (J650)	8.1-3
Table 8.1-3. FLASH (U803) Pinout	8.1-3
Table 8.1-4. SRAM (U804) Pinout	8.1-6
Table 8.1-5. Patriot MCU/DSP (U800) Pinout	8.1-7
Table 8.1-6. MAKO (U701) Pinout	8.1-16
Table 8.2-1. Main Board to Keypad Board Flex Assembly (J601)	8.2-1
Table 8.2-2. Main Board to Universal (Side) Connector Flex Assembly (J650)	8.2-3
Table 8.2-3. FLASH (U803) Pinout	8.2-3
Table 8.2-4. SRAM (U804) Pinout	8.2-6
Table 8.2-5. Patriot MCU/DSP (U800) Pinout	8.2-7

Table 8.2-6. MAKO (U701) Pinout	8.2-16
Table 8.3-1. Main Board to Keypad Board Flex Assembly (J601)	8.3-1
Table 8.3-2. Main Board to Universal (Side) Connector Flex Assembly (J650)	8.3-3
Table 8.3-3. FLASH (U803) Pinout	8.3-3
Table 8.3-4. SRAM (U804) Pinout	8.3-6
Table 8.3-5. Patriot MCU/DSP (U800) Pinout	8.3-7
Table 8.3-6. MAKO (U701) Pinout	8.3-16
Table 8.4-1. Main Board to Keypad Board Flex Assembly (J601)	8.4-1
Table 8.4-2. Main Board to Universal (Side) Connector Flex Assembly (J650)	8.4-3
Table 8.4-3. FLASH (U803) Pinout	8.4-3
Table 8.4-4. SRAM (U804) Pinout	8.4-6
Table 8.4-5. Patriot MCU/DSP (U800) Pinout	8.4-7
Table 8.4-6. MAKO (U701) Pinout	8.4-16
Table 8.5-1. Main Board to Keypad Board Flex Assembly (J601)	8.5-1
Table 8.5-2. Main Board to Universal (Side) Connector Flex Assembly (J650)	8.5-3
Table 8.5-3. FLASH (U803) Pinout	8.5-3
Table 8.5-4. SRAM (U804) Pinout	8.5-6
Table 8.5-5. Patriot MCU/DSP (U800) Pinout	8.5-7
Table 8.5-6. MAKO (U701) Pinout	8.5-16
Table 9.1-1. VHF Schematics, Board Overlays and Parts Lists	9.1-1
Table 9.2-1. UHF1 Schematics, Board Overlays and Parts Lists	9.2-1
Table 9.3-1. UHF2 Schematics, Board Overlays and Parts Lists	9.3-1
Table 9.4-1. 700/800 Schematics, Board Overlays and Parts Lists	9.4-1
Table 9.5-1. 900MHz Schematics, Board Overlays and Parts Lists	9.5-1

Related Publications

ASTRO XTS 2500/XTS 2500I Digital Portable Radio User Guide (CD) (all models)	PMLN4940_
ASTRO XTS 2500 Digital Portable Radio Basic Service Manual	6816984H01
ASTRO XTS 2250 Digital Portable Radio Basic Model User Guide (CD)	PMLN4942_
ASTRO XTS 2250 Digital Portable Radio Model 1.5 User Guide (CD)	PMLN4942_
ASTRO XTS 2250 Digital Portable Radio Advanced Model User Guide (CD)	PMLN4942_
ASTRO XTS 1500 Digital Portable Radio User Guide (CD)	PMLN4940_
MT 1500 Analog Portable Radio User Guide (CD)	PMLN4940_
PR 1500 Analog Portable Radio User Guide (CD)	PMLN4943_
Factory Mutual Approval: MT 1500/XTS 1500/PR 1500/XTS 2500/XTS 2500I/XTS 2250 Product Listing	6881094C77

Chapter 1 Introduction

1.1 General

This manual includes all the information needed to maintain peak product performance and maximum working-time. This detailed level of service (component level) is typical of some service centers, self-maintained customers, and distributors. This manual is to be used in conjunction with the ASTRO XTS 2500/XTS 2500I Digital Portable Radios Basic Service Manual (Motorola part number 6816984H01), which uses the pass/fail service approach to radio problems.

Conduct the basic performance checks first. This will verify the actual need for analyzing the radio and help pinpoint the functional problem area. In addition, the technician will become familiar with the radio test mode of operation, which is a helpful tool. If any basic receive or transmitter parameters fail, then the radio should be aligned per the radio alignment procedure.

Included in other areas of this manual are disassembly/reassembly procedures, functional block diagrams, detailed theory of operation, troubleshooting charts and waveforms, schematics and parts lists, and exploded view and parts list. The technician should be very familiar with these sections to aid in determining the problem circuit. Also included are component location diagrams to aid in locating individual circuit components and some IC diagrams, which point out some convenient probe points.

The theory of operation sections of this manual contain detailed descriptions of the operations of many circuits. Once the area of the problem is located, it would be strongly advisable to review the operation of the circuit pertaining to the troubleshooting flow chart.

1.2 Notations Used in This Manual

Throughout the text in this publication, you will notice the use of warning, caution, and note notations. These notations are used to emphasize that safety hazards exist, and care must be taken and observed.

NOTE: An operational procedure, practice, or condition, etc., which is essential to emphasize.



Caution

CAUTION indicates a potentially hazardous situation which, if not avoided, may result in equipment damage.



WARNING

WARNING indicates a potentially hazardous situation which, if not avoided, could result in death or injury.



DANGER indicates an imminently hazardous situation which, if not avoided, will result in death or injury.

In this publication you will also find the use of the asterisk (*) to indicate a negative or NOT logic true signal.

Chapter 2.1 VHF Overall Characteristics

2.1.1 Introduction

This manual is to be used in conjunction with the ASTRO XTS 2500/XTS 2500I Digital Portable Radios Basic Service Manual (Motorola part number 6816984H01), which uses the pass/fail service approach to radio problems.

The ASTRO XTS 2500/XTS 2500I digital portable radio is a dual-band, (trunked/conventional), microcontroller-based transceiver incorporating a Digital Signal Processor (DSP). The microcontroller handles the general radio control, monitors status, and processes commands input from the keypad or other user controls. The DSP processes the typical analog signals and generates the standard signaling digitally to provide compatibility with existing analog systems. In addition, it provides for digital modulation techniques, utilizing voice encoding techniques with error correction schemes, to provide the user with enhanced range and audio quality all in a reduced bandwidth channel requirement. It allows embedded signaling which can mix system information and data with digital voice to add the capability of supporting a multitude of system features.

The three ASTRO XTS 2500/XTS 2500I digital portable radio models (I, II, and III) are available in the VHF (136-174 MHz) band.

The ASTRO XTS 2500/XTS 2500I digital portable radio consists of:

- a **main board**,
- a **universal flex**, and
- **display** and **keypad** assemblies (models II and III only).
- **display** only with **no keypad** (model 1.5 only)

The **main board** contains the microcontroller unit (MCU) and its associated memory and memory management integrated circuit (IC), the audio power amplifier, and a switching regulator. The board also contains the digital signal processor (DSP) and its support IC and associated memories. All transmit, receive, and frequency generation circuitry, including the digital receiver back-end IC and the reference oscillator are included on the main board.

The **universal flex** contains the universal connector, speaker, and a microphone.

The **display** module is a six-line x 12-character, liquid-crystal display (LCD) with associated circuitry. This module utilizes chip-on-flex technology and is not considered field-repairable.

The **keypad** module is either a 3 x 2 (Model II), or a 3 x 6 (Model III) button module with backlighting.

2.1.2 Analog Mode of Operation-Receiving

When the radio is *receiving*, the signal comes from the antenna connector to the radio board, passes through the RX/TX switch and the receiver front end. The signal is then filtered, amplified, and mixed with the first local-oscillator signal generated by the voltage-controlled oscillator (VCO).

The resulting intermediate frequency (IF) signal (44.85 MHz) is fed to the IF circuitry, where the signal is again filtered and amplified. This amplified signal is passed to the digital back-end IC, where it is mixed with the second local oscillator to create the second IF at 2.25 MHz. It is then converted to a digital bit stream and mixed a third time to produce a baseband signal. This signal is passed to the Vocoder and Controller (VOCON) circuitry through a current-driven output. Please see page 4.1-5 for a detailed description of the VOCON functional blocks.

In the VOCON circuitry, the DSP decodes the information in the signal and identifies the appropriate destination for it. For a voice signal, the DSP will route the digital voice data to the CODEC for conversion to an analog signal. The CODEC will then present the signal to the audio power amplifier, which drives the speaker. For signaling information, the DSP will decode the message and pass it to the microcontroller unit.

2.1.3 Analog Mode of Operation-Transmitting

When the radio is *transmitting*, microphone audio is passed through gain stages to the CODEC, where the signal is digitized. The CODEC passes digital data to the DSP, where pre-emphasis and low-pass (splatter) filtering is done. The DSP returns this signal to a digital-to-analog converter (D/A), where it is reconverted into an analog signal and scaled for application to the voltage-controlled oscillator as a modulation signal.

Transmitted signaling information is accepted by the DSP from the microcontroller unit, coded appropriately, and passed to the D/A, which handles it the same as a voice signal. Modulation information is passed to the synthesizer along the modulation line. A modulated carrier is provided to the RF PA, which transmits the signal under dynamic power control.

2.1.4 ASTRO Mode (Digital Mode) of Operation

In the ASTRO mode (digital mode) of operation, the transmitted or received signal is limited to a discrete set of deviation levels, instead of varying continuously. The receiver handles an ASTRO-mode signal identically to an analog-mode signal up to the point where the DSP decodes the received data. In the ASTRO receive mode, the DSP uses a specifically defined algorithm to recover information.

In the ASTRO transmit mode, microphone audio is processed identically to an analog mode, with the exception of the algorithm the DSP uses to encode the information. This algorithm will result in deviation levels that are limited to discrete levels.

2.1.5 Main Board Overview

The receiver front end consists of two wide-band varactor-tunable filters:

1. a wide-band, low-noise amplifier, and
2. an active mixer stage.

The receive path of the antenna switch feeds directly into a preselector filter, followed by a Low Noise Amplifier (LNA) and a post-selector filter, then the mixer. Both front-end filters are implemented as multi-layer ceramic (MLC), with embedded Inductor Capacitor (LC) components. Both filters are supplied with a single control voltage from one of the Power Control IC DACs (Digital-to-Analog Converters). The output of the post-selector filter is sent to the active mixer stage.

The frequency generation function is performed by three ICs and associated circuitry. The reference oscillator provides a frequency standard to the synthesizer/prescaler IC, which controls the Voltage-Controlled Oscillator Buffer (VCOB) IC. The synthesizer/prescaler circuit module incorporates frequency-division and comparison circuitry to keep the VCO signals stable. The synthesizer/prescaler IC is controlled by the microcontroller unit through a serial bus.

The receiver back end consists of a single, three-pole crystal filter and the digital back-end IC (ABACUS-III). Final IF filtering is done digitally in the DSP.

The digital back-end IC (ABACUS-III) consists of the following:

- an amplifier
- the second mixer
- an IF analog-to-digital converter
- a baseband down-converter, and
- a 18 MHz synthesis circuit to provide a sampling clock to the circuitry. The second LO is generated by discrete components external to the IC. The output of the ABACUS-III IC is a current-driven digital bit stream.

The transmitter consists of an RF driver IC and a final stage power amplifier. The RF driver IC gets an injection signal from the VCO. Transmit power is controlled by a power-control IC that monitors the output of a directional coupler and adjusts the PA control voltages correspondingly. The signal passes through a RX/TX switch that uses PIN diodes to automatically provide an appropriate interface to transmit or receive signals.

2.1.6 Vocoder Circuitry Overview

In the VOCON circuitry, the digital-signal processor (DSP) supports IC digital filters, discriminates the signal, and passes it to the DSP. The DSP decodes the information in the signal and identifies the following destination for the signal:

- For a voice signal, the DSP routes the digital voice data to the Coder-Decoder (CODEC) for conversion to an analog signal. The CODEC then presents the signal to the audio pre-amplifier and audio power amplifier (integrated into the MAKO IC), which drives the speaker.
- For signaling information, the DSP decodes the message and passes it to the microcontroller unit.

Notes

Chapter 2.2 UHF1 Overall Characteristics

2.2.1 Introduction

This manual is to be used in conjunction with the ASTRO XTS 2500/XTS 2500I Digital Portable Radios Basic Service Manual (Motorola part number 6816984H01), which uses the pass/fail service approach to radio problems.

The ASTRO XTS 2500/XTS 2500I digital portable radio is a dual-band, (trunked/conventional), microcontroller-based transceiver incorporating a Digital Signal Processor (DSP). The microcontroller handles the general radio control, monitors status, and processes commands input from the keypad or other user controls. The DSP processes the typical analog signals and generates the standard signaling digitally to provide compatibility with existing analog systems. In addition, it provides for digital modulation techniques, utilizing voice encoding techniques with error correction schemes, to provide the user with enhanced range and audio quality all in a reduced bandwidth channel requirement. It allows embedded signaling which can mix system information and data with digital voice to add the capability of supporting a multitude of system features.

The three ASTRO XTS 2500/XTS 2500I digital portable radio models (I, II, and III) are available in the UHF Range 1 (380 - 470 MHz) band.

The ASTRO XTS 2500/XTS 2500I digital portable radio consists of:

- a **main board**,
- a **universal flex**, and
- **display** and **keypad** assemblies (models II and III only).
- **display** only with **no keypad** (model 1.5 only)

The **main board** contains the microcontroller unit (MCU) and its associated memory and memory management integrated circuit (IC), the audio power amplifier, and a switching regulator. The board also contains the digital signal processor (DSP) and its support IC and associated memories. All transmit, receive, and frequency generation circuitry, including the digital receiver back-end IC and the reference oscillator are included on the main board.

The **universal flex** contains the universal connector, speaker, and a microphone.

The **display** module is a six-line x 12-character, liquid-crystal display (LCD) with associated circuitry. This module utilizes chip-on-flex technology and is not considered field-repairable.

The **keypad** module is either a 3 x 2 (Model II), or a 3 x 6 (Model III) button module with backlighting.

2.2.2 Analog Mode of Operation-Receiving

When the radio is *receiving*, the signal comes from the antenna connector to the radio board, passes through the RX/TX switch and the receiver front end. The signal is then filtered, amplified, and mixed with the first local-oscillator signal generated by the voltage-controlled oscillator (VCO).

The resulting intermediate frequency (IF) signal (73.35 MHz) is fed to the IF circuitry, where the signal is again filtered and amplified. This amplified signal is passed to the digital back-end IC, where it is mixed with the second local oscillator to create the second IF at 2.25 MHz. It is then converted to a digital bit stream and mixed a third time to produce a baseband signal. This signal is passed to the Vocoder and Controller (VOCON) circuitry through a current-driven output. Please see page 4.2-5 for a detailed description of the VOCON functional blocks.

In the VOCON circuitry, the DSP decodes the information in the signal and identifies the appropriate destination for it. For a voice signal, the DSP will route the digital voice data to the CODEC for conversion to an analog signal. The CODEC will then present the signal to the audio power amplifier, which drives the speaker. For signaling information, the DSP will decode the message and pass it to the microcontroller unit.

2.2.3 Analog Mode of Operation-Transmitting

When the radio is *transmitting*, microphone audio is passed through gain stages to the CODEC, where the signal is digitized. The CODEC passes digital data to the DSP, where pre-emphasis and low-pass (splatter) filtering is done. The DSP returns this signal to a digital-to-analog converter (D/A), where it is reconverted into an analog signal and scaled for application to the voltage-controlled oscillator as a modulation signal.

Transmitted signaling information is accepted by the DSP from the microcontroller unit, coded appropriately, and passed to the D/A, which handles it the same as a voice signal. Modulation information is passed to the synthesizer along the modulation line. A modulated carrier is provided to the RF PA, which transmits the signal under dynamic power control.

2.2.4 ASTRO Mode (Digital Mode) of Operation

In the ASTRO mode (digital mode) of operation, the transmitted or received signal is limited to a discrete set of deviation levels, instead of varying continuously. The receiver handles an ASTRO-mode signal identically to an analog-mode signal up to the point where the DSP decodes the received data. In the ASTRO receive mode, the DSP uses a specifically defined algorithm to recover information.

In the ASTRO transmit mode, microphone audio is processed identically to an analog mode, with the exception of the algorithm the DSP uses to encode the information. This algorithm will result in deviation levels that are limited to discrete levels.

2.2.5 Main RF Board Overview

The receiver front end consists of :

1. Two wide-band varactor-tunable filters.
2. Wide-band, low-noise amplifier.
3. Active mixer stage.

The receive path of the antenna switch feeds directly into a preselector filter, followed by a Low Noise Amplifier (LNA) and a post-selector filter, then the mixer. Both filters are supplied with a single control voltage from one of the Power Control IC DACs (Digital-to-Analog Converters). The output of the post-selector filter is sent to the active mixer stage.

The frequency generation function is performed by two ICs and its associated circuitries. The reference oscillator provides a frequency standard to the synthesizer/prescaler IC, which controls the Receive (RX) and Transmit (TX) Voltage Controlled Oscillators. The synthesizer/prescaler circuit module incorporates frequency-division and comparison circuitry to keep the VCO signals stable. The synthesizer/prescaler IC is controlled by the microcontroller unit through a serial bus.

The digital back-end IC (ABACUS-III) consists of the following:

- an amplifier
- the second mixer
- an IF analog-to-digital converter
- a baseband down-converter, and
- a 18 MHz synthesis circuit to provide a sampling clock to the circuitry. The second LO is generated by discrete components external to the IC. The output of the ABACUS-III IC is a current-driven digital bit stream.

The transmitter consists of an RF driver IC and a final stage power amplifier. The RF driver IC gets an injection signal from the VCO. Transmit power is controlled by a power-control IC that monitors the output of a directional coupler and adjusts the PA control voltages correspondingly. The signal passes through a RX/TX switch that uses PIN diodes to automatically provide an appropriate interface to transmit or receive signals.

2.2.6 Vocoder Circuitry Overview

In the VOCON circuitry, the digital-signal processor (DSP) supports IC digital filters, discriminates the signal, and passes it to the DSP. The DSP decodes the information in the signal and identifies the following destination for the signal:

- For voice signal, the DSP routes the digital voice data to the Coder-Decoder (CODEC) for conversion to an analog signal. The CODEC then presents the signal to the audio pre-amplifier and audio power amplifier (integrated into the MAKO IC), which drives the speaker.
- For signaling information, the DSP decodes the message and passes it to the microcontroller unit.

Notes

Chapter 2.3 UHF2 Overall Characteristics

2.3.1 Introduction

This manual is to be used in conjunction with the ASTRO XTS 2500/XTS 2500I Digital Portable Radios Basic Service Manual (Motorola part number 6816984H01), which uses the pass/fail service approach to radio problems.

The ASTRO XTS 2500/XTS 2500I digital portable radio is a dual-band, (trunked/conventional), microcontroller-based transceiver incorporating a Digital Signal Processor (DSP). The microcontroller handles the general radio control, monitors status, and processes commands input from the keypad or other user controls. The DSP processes the typical analog signals and generates the standard signaling digitally to provide compatibility with existing analog systems. In addition, it provides for digital modulation techniques, utilizing voice encoding techniques with error correction schemes, to provide the user with enhanced range and audio quality all in a reduced bandwidth channel requirement. It allows embedded signaling which can mix system information and data with digital voice to add the capability of supporting a multitude of system features.

The three ASTRO XTS 2500/XTS 2500I digital portable radio models (I, II, and III) are available in the UHF Range 2 (450 - 520 MHz) band.

The ASTRO XTS 2500/XTS 2500I digital portable radio consists of:

- a **main board**,
- a **universal flex**, and
- **display** and **keypad** assemblies (models II and III only).
- **display** only with **no keypad** (model 1.5 only)

The **main board** contains the microcontroller unit (MCU) and its associated memory and memory management integrated circuit (IC), the audio power amplifier, and a switching regulator. The board also contains the digital signal processor (DSP) and its support IC and associated memories. All transmit, receive, and frequency generation circuitry, including the digital receiver back-end IC and the reference oscillator are included on the main board.

The **universal flex** contains the universal connector, speaker, and a microphone.

The **display** module is a six-line x 12-character, liquid-crystal display (LCD) with associated circuitry. This module utilizes chip-on-flex technology and is not considered field-repairable.

The **keypad** module is either a 3 x 2 (Model II), or a 3 x 6 (Model III) button module with backlighting.

2.3.2 Analog Mode of Operation-Receiving

When the radio is *receiving*, the signal comes from the antenna connector to the radio board, passes through the RX/TX switch and the receiver front end. The signal is then filtered, amplified, and mixed with the first local-oscillator signal generated by the voltage-controlled oscillator (VCO).

The resulting intermediate frequency (IF) signal (73.35 MHz) is fed to the IF circuitry, where the signal is again filtered and amplified. This amplified signal is passed to the digital back-end IC, where it is mixed with the second local oscillator to create the second IF at 2.25 MHz. It is then converted to a digital bit stream and mixed a third time to produce a baseband signal. This signal is passed to the Vocoder and Controller (VOCON) circuitry through a current-driven output. Please see page 4.3-5 for a detailed description of the VOCON functional blocks.

In the VOCON circuitry, the DSP decodes the information in the signal and identifies the appropriate destination for it. For a voice signal, the DSP will route the digital voice data to the CODEC for conversion to an analog signal. The CODEC will then present the signal to the audio power amplifier, which drives the speaker. For signaling information, the DSP will decode the message and pass it to the microcontroller unit.

2.3.3 Analog Mode of Operation-Transmitting

When the radio is *transmitting*, microphone audio is passed through gain stages to the CODEC, where the signal is digitized. The CODEC passes digital data to the DSP, where pre-emphasis and low-pass (splatter) filtering is done. The DSP returns this signal to a digital-to-analog converter (D/A), where it is reconverted into an analog signal and scaled for application to the voltage-controlled oscillator as a modulation signal.

Transmitted signaling information is accepted by the DSP from the microcontroller unit, coded appropriately, and passed to the D/A, which handles it the same as a voice signal. Modulation information is passed to the synthesizer along the modulation line. A modulated carrier is provided to the RF PA, which transmits the signal under dynamic power control.

2.3.4 ASTRO Mode (Digital Mode) of Operation

In the ASTRO mode (digital mode) of operation, the transmitted or received signal is limited to a discrete set of deviation levels, instead of varying continuously. The receiver handles an ASTRO-mode signal identically to an analog-mode signal up to the point where the DSP decodes the received data. In the ASTRO receive mode, the DSP uses a specifically defined algorithm to recover information.

In the ASTRO transmit mode, microphone audio is processed identically to an analog mode, with the exception of the algorithm the DSP uses to encode the information. This algorithm will result in deviation levels that are limited to discrete levels.

2.3.5 Main RF Board Overview

The receiver front end consists of:

1. Two wide-band varactor-tunable filters.
2. Wide-band, low-noise amplifier.
3. Active mixer stage.

The receive path of the antenna switch feeds directly into a preselector filter, followed by a Low Noise Amplifier (LNA) and a post-selector filter, then the mixer. Both filters are supplied with a single control voltage from one of the Power Control IC DACs (Digital-to-Analog Converters). The output of the post-selector filter is sent to the active mixer stage.

The frequency generation function is performed by two ICs and its associated circuitries. The reference oscillator provides a frequency standard to the synthesizer/prescaler IC, which controls the Receive (RX) and Transmit (TX) Voltage Controlled Oscillators. The synthesizer/prescaler circuit module incorporates frequency-division and comparison circuitry to keep the VCO signals stable. The synthesizer/prescaler IC is controlled by the microcontroller unit through a serial bus.

The digital back-end IC (ABACUS-III) consists of the following:

- an amplifier
- the second mixer
- an IF analog-to-digital converter
- a baseband down-converter, and
- a 18 MHz synthesis circuit to provide a sampling clock to the circuitry. The second LO is generated by discrete components external to the IC. The output of the ABACUS-III IC is a current-driven digital bit stream.

The transmitter consists of an RF driver IC and a final stage power amplifier. The RF driver IC gets an injection signal from the VCO. Transmit power is controlled by a power-control IC that monitors the output of a directional coupler and adjusts the PA control voltages correspondingly. The signal passes through a RX/TX switch that uses PIN diodes to automatically provide an appropriate interface to transmit or receive signals.

2.3.6 Vocoder Circuitry Overview

In the VOCON circuitry, the digital-signal processor (DSP) supports IC digital filters, discriminates the signal, and passes it to the DSP. The DSP decodes the information in the signal and identifies the following destination for the signal:

- For voice signal, the DSP routes the digital voice data to the Coder-Decoder (CODEC) for conversion to an analog signal. The CODEC then presents the signal to the audio pre-amplifier and audio power amplifier (integrated into the MAKO IC), which drives the speaker.
- For signaling information, the DSP decodes the message and passes it to the microcontroller unit.

Notes

Chapter 2.4 700/800 MHz Overall Characteristics

2.4.1 Introduction

This manual is to be used in conjunction with the ASTRO XTS 2500/XTS 2500I Digital Portable Radios Basic Service Manual (Motorola part number 6816984H01), which uses the pass/fail service approach to radio problems.

The ASTRO XTS 2500/XTS 2500I digital portable radio is a dual-band, (trunked/conventional), microcontroller-based transceiver incorporating a Digital Signal Processor (DSP). The microcontroller handles the general radio control, monitors status, and processes commands input from the keypad or other user controls. The DSP processes the typical analog signals and generates the standard signaling digitally to provide compatibility with existing analog systems. In addition, it provides for digital modulation techniques, utilizing voice encoding techniques with error correction schemes, to provide the user with enhanced range and audio quality all in a reduced bandwidth channel requirement. It allows embedded signaling which can mix system information and data with digital voice to add the capability of supporting a multitude of system features.

The three ASTRO XTS 2500/XTS 2500I digital portable radio models (I, II, and III) are available in the 700/800 MHz (764-870 MHz) band.

The ASTRO XTS 2500/XTS 2500I digital portable radio consists of:

- a **main board**,
- a **universal flex**, and
- **display** and **keypad** assemblies (models II and III only).
- **display** only with **no keypad** (model 1.5 only)

The **main board** contains the microcontroller unit (MCU) and its associated memory and memory management integrated circuit (IC), the audio power amplifier, and a switching regulator. The board also contains the digital signal processor (DSP) and its support IC and associated memories. All transmit, receive, and frequency generation circuitry, including the digital receiver back-end IC and the reference oscillator are included on the main board.

The **universal flex** contains the universal connector, speaker, and a microphone.

The **display** module is a six-line x 12-character, liquid-crystal display (LCD) with associated circuitry. This module utilizes chip-on-flex technology and is not considered field-repairable.

The **keypad** module is either a 3 x 2 (Model II), or a 3 x 6 (Model III) button module with backlighting.

2.4.2 Analog Mode of Operation-Receiving

When the radio is *receiving*, the signal comes from the antenna connector to the radio board, passes through the RX/TX switch and the receiver front end. The signal is then filtered, amplified, and mixed with the first local-oscillator signal generated by the voltage-controlled oscillator (VCO).

The resulting intermediate frequency (IF) signal (109.65 MHz) is fed to the IF circuitry, where the signal is again filtered and amplified. This amplified signal is passed to the digital back-end IC, where it is mixed with the second local oscillator to create the second IF at 2.25 MHz. It is then converted to a digital bit stream and mixed a third time to produce a baseband signal. This signal is passed to the Vocoder and Controller (VOCON) circuitry through a current-driven output. Please see page 4.4-5 for a detailed description of the VOCON functional blocks.

In the VOCON circuitry, the DSP decodes the information in the signal and identifies the appropriate destination for it. For a voice signal, the DSP will route the digital voice data to the CODEC for conversion to an analog signal. The CODEC will then present the signal to the audio power amplifier, which drives the speaker. For signaling information, the DSP will decode the message and pass it to the microcontroller unit.

2.4.3 Analog Mode of Operation-Transmitting

When the radio is *transmitting*, microphone audio is passed through gain stages to the CODEC, where the signal is digitized. The CODEC passes digital data to the DSP, where pre-emphasis and low-pass (splatter) filtering is done. The DSP returns this signal to a digital-to-analog converter (D/A), where it is reconverted into an analog signal and scaled for application to the voltage-controlled oscillator as a modulation signal.

Transmitted signaling information is accepted by the DSP from the microcontroller unit, coded appropriately, and passed to the D/A, which handles it the same as a voice signal. Modulation information is passed to the synthesizer along the modulation line. A modulated carrier is provided to the RF PA, which transmits the signal under dynamic power control.

2.4.4 ASTRO Mode (Digital Mode) of Operation

In the ASTRO mode (digital mode) of operation, the transmitted or received signal is limited to a discrete set of deviation levels, instead of varying continuously. The receiver handles an ASTRO-mode signal identically to an analog-mode signal up to the point where the DSP decodes the received data. In the ASTRO receive mode, the DSP uses a specifically defined algorithm to recover information.

In the ASTRO transmit mode, microphone audio is processed identically to an analog mode, with the exception of the algorithm the DSP uses to encode the information. This algorithm will result in deviation levels that are limited to discrete levels.

2.4.5 Main Board Overview

The receiver front end consists of two wide-band varactor-tunable filters:

1. a wide-band, low-noise amplifier, and
2. an active mixer stage.

The receive path of the antenna switch feeds directly into a preselector filter, followed by a Low Noise Amplifier (LNA) and a post-selector filter, then the mixer. Both filters are supplied with a single control voltage from one of the Power Control IC DACs (Digital-to-Analog Converters). The output of the post-selector filter is sent to the active mixer stage.

The frequency generation function is performed by three ICs and associated circuitry. The reference oscillator provides a frequency standard to the synthesizer/prescaler IC, which controls the Voltage-Controlled Oscillator Buffer (VCOB) IC. The synthesizer/prescaler circuit module incorporates frequency-division and comparison circuitry to keep the VCO signals stable. The synthesizer/prescaler IC is controlled by the microcontroller unit through a serial bus.

The receiver back end consists of a single, three-pole crystal filter and the digital back-end IC (ABACUS-III). Final IF filtering is done digitally in the DSP.

The digital back-end IC (ABACUS-III) consists of the following:

- an amplifier
- the second mixer
- an IF analog-to-digital converter
- a baseband down-converter, and
- a 18 MHz synthesis circuit to provide a sampling clock to the circuitry. The second LO is generated by discrete components external to the IC. The output of the ABACUS-III IC is a current-driven digital bit stream.

The transmitter consists of an RF driver IC and a final stage power amplifier. The RF driver IC gets an injection signal from the VCO. Transmit power is controlled by a power-control IC that monitors the output of a directional coupler and adjusts the PA control voltages correspondingly. The signal passes through a RX/TX switch that uses PIN diodes to automatically provide an appropriate interface to transmit or receive signals.

2.4.6 Vocoder Circuitry Overview

In the VOCON circuitry, the digital-signal processor (DSP) supports IC digital filters, discriminates the signal, and passes it to the DSP. The DSP decodes the information in the signal and identifies the following destination for the signal:

- For a voice signal, the DSP routes the digital voice data to the Coder-Decoder (CODEC) for conversion to an analog signal. The CODEC then presents the signal to the audio pre-amplifier and audio power amplifier (integrated into the MAKO IC), which drives the speaker.
- For signaling information, the DSP decodes the message and passes it to the microcontroller unit.

Notes

Chapter 2.5 900MHz Overall Characteristics

2.5.1 Introduction

This manual is to be used in conjunction with the ASTRO XTS 2500/XTS 2500I Digital Portable Radios Basic Service Manual (Motorola part number 6816984H01), which uses the pass/fail service approach to radio problems.

The ASTRO XTS 2500/XTS 2500I digital portable radio is a dual-band, (trunked/conventional), microcontroller-based transceiver incorporating a Digital Signal Processor (DSP). The microcontroller handles the general radio control, monitors status, and processes commands input from the keypad or other user controls. The DSP processes the typical analog signals and generates the standard signaling digitally to provide compatibility with existing analog systems. In addition, it provides for digital modulation techniques, utilizing voice encoding techniques with error correction schemes, to provide the user with enhanced range and audio quality all in a reduced bandwidth channel requirement. It allows embedded signaling which can mix system information and data with digital voice to add the capability of supporting a multitude of system features.

The three ASTRO XTS 2500/XTS 2500I digital portable radio models (I, II, and III) are available in the 900 MHz (896-941 MHz) band.

The ASTRO XTS 2500/XTS 2500I digital portable radio consists of:

- a **main board**,
- a **universal flex**, and
- **display** and **keypad** assemblies (models II and III only).
- **display** only with **no keypad** (model 1.5 only)

The **main board** contains the microcontroller unit (MCU) and its associated memory and memory management integrated circuit (IC), the audio power amplifier, and a switching regulator. The board also contains the digital signal processor (DSP) and its support IC and associated memories. All transmit, receive, and frequency generation circuitry, including the digital receiver back-end IC and the reference oscillator are included on the main board.

The **universal flex** contains the universal connector, speaker, and a microphone.

The **display** module is a six-line x 12-character, liquid-crystal display (LCD) with associated circuitry. This module utilizes chip-on-flex technology and is not considered field-repairable.

The **keypad** module is either a 3 x 2 (Model II), or a 3 x 6 (Model III) button module with backlighting.

2.5.2 Analog Mode of Operation-Receiving

When the radio is *receiving*, the signal comes from the antenna connector to the radio board, passes through the RX/TX switch and the receiver front end. The signal is then filtered, amplified, and mixed with the first local-oscillator signal generated by the voltage-controlled oscillator (VCO).

The resulting intermediate frequency (IF) signal (109.65 MHz) is fed to the IF circuitry, where the signal is again filtered and amplified. This amplified signal is passed to the digital back-end IC, where it is mixed with the second local oscillator to create the second IF at 2.25 MHz. It is then converted to a digital bit stream and mixed a third time to produce a baseband signal. This signal is passed to the Vocoder and Controller (VOCON) circuitry through a current-driven output. Please see page 4.5-5 for a detailed description of the VOCON functional blocks.

In the VOCON circuitry, the DSP decodes the information in the signal and identifies the appropriate destination for it. For a voice signal, the DSP will route the digital voice data to the CODEC for conversion to an analog signal. The CODEC will then present the signal to the audio power amplifier, which drives the speaker. For signaling information, the DSP will decode the message and pass it to the microcontroller unit.

2.5.3 Analog Mode of Operation-Transmitting

When the radio is *transmitting*, microphone audio is passed through gain stages to the CODEC, where the signal is digitized. The CODEC passes digital data to the DSP, where pre-emphasis and low-pass (splatter) filtering is done. The DSP returns this signal to a digital-to-analog converter (D/A), where it is reconverted into an analog signal and scaled for application to the voltage-controlled oscillator as a modulation signal.

Transmitted signaling information is accepted by the DSP from the microcontroller unit, coded appropriately, and passed to the D/A, which handles it the same as a voice signal. Modulation information is passed to the synthesizer along the modulation line. A modulated carrier is provided to the RF PA, which transmits the signal under dynamic power control.

2.5.4 ASTRO Mode (Digital Mode) of Operation

In the ASTRO mode (digital mode) of operation, the transmitted or received signal is limited to a discrete set of deviation levels, instead of varying continuously. The receiver handles an ASTRO-mode signal identically to an analog-mode signal up to the point where the DSP decodes the received data. In the ASTRO receive mode, the DSP uses a specifically defined algorithm to recover information.

In the ASTRO transmit mode, microphone audio is processed identically to an analog mode, with the exception of the algorithm the DSP uses to encode the information. This algorithm will result in deviation levels that are limited to discrete levels.

2.5.5 Main Board Overview

The receiver front end consists of two wide-band varactor-tunable filters:

1. a wide-band, low-noise amplifier, and
2. an active mixer stage.

The receive path of the antenna switch feeds directly into a preselector filter, followed by a Low Noise Amplifier (LNA) and a post-selector filter, then the mixer. Both filters are supplied with a single control voltage from one of the Power Control IC DACs (Digital-to-Analog Converters). The output of the post-selector filter is sent to the active mixer stage.

The frequency generation function is performed by three ICs and associated circuitry. The reference oscillator provides a frequency standard to the synthesizer/prescaler IC, which controls the Voltage-Controlled Oscillator Buffer (VCOB) IC. The synthesizer/prescaler circuit module incorporates frequency-division and comparison circuitry to keep the VCO signals stable. The synthesizer/prescaler IC is controlled by the microcontroller unit through a serial bus.

The receiver back end consists of a single, three-pole crystal filter and the digital back-end IC (ABACUS-III). Final IF filtering is done digitally in the DSP.

The digital back-end IC (ABACUS-III) consists of the following:

- an amplifier
- the second mixer
- an IF analog-to-digital converter
- a baseband down-converter, and
- a 18 MHz synthesis circuit to provide a sampling clock to the circuitry. The second LO is generated by discrete components external to the IC. The output of the ABACUS-III IC is a current-driven digital bit stream.

The transmitter consists of an RF driver IC and a final stage power amplifier. The RF driver IC gets an injection signal from the VCO. Transmit power is controlled by a power-control IC that monitors the output of a directional coupler and adjusts the PA control voltages correspondingly. The signal passes through a RX/TX switch that uses PIN diodes to automatically provide an appropriate interface to transmit or receive signals.

2.5.6 Vocoder Circuitry Overview

In the VOCON circuitry, the digital-signal processor (DSP) supports IC digital filters, discriminates the signal, and passes it to the DSP. The DSP decodes the information in the signal and identifies the following destination for the signal:

- For a voice signal, the DSP routes the digital voice data to the Coder-Decoder (CODEC) for conversion to an analog signal. The CODEC then presents the signal to the audio pre-amplifier and audio power amplifier (integrated into the MAKO IC), which drives the speaker.
- For signaling information, the DSP decodes the message and passes it to the microcontroller unit.

Notes

Chapter 3.1 VHF Radio Power

3.1.1 Introduction

This chapter of the manual provides a detailed circuit description of the power distribution for an ASTRO XTS 2500/XTS 2500I digital portable radio. This manual is to be used in conjunction with the ASTRO XTS 2500/XTS 2500I Digital Portable Radios Basic Service Manual (Motorola part number 6816984H01), which uses the pass/fail service approach to radio problems.

3.1.2 Radio Power Up or Down

Radio power up begins when the radio ON/OFF/Volume control knob is turned to the on position, placing 7.5 volts on the MECH_SW line. This signal activates the pass element (Q700, Q701 and Q703), enabling SW_B+ and RFSW_B+.

When the MAKO IC (U701) detects a low to high voltage transition on the MECH_SW pin, it grounds the FET_ENX pin (or VPP_EN) driving the gate of an external P-MOSFET (Q700 and Q703) low. This turns ON the transistors Q700 and Q703 and applies SW_B+ to MAKO IC and VoCon and RF_SWB+ to the RF section of the board. After application of the power to SW_B+, the regulators VSW1, VSW2, V1.875, V1.55, V2.9 and VCC5 are sequenced on. After the regulators are stable, the RESETX pin is asserted low for an additional 16ms and then de-asserted allowing the dual-core processor to start.

The radio power down sequence begins by opening the radio ON/OFF switch, causing the MECH_SW pin to transition high. This causes the MAKO IC to start an internal 125ms watchdog timer and drive the INT_X pin (or MAKO_INT) interrupt output pin low. The dual-core processor then determines (through communication on the SPI bus) that it must initiate the power-down sequence. At this point, the watchdog timer can be kept alive by the dual-core processor (via the SPI bus) allowing for software cleanup. Upon expiration of the watchdog timer, the MAKO IC asserts the RESETX pin and turns off all DC regulators including SW_B+ and RF_SWB+ (Q700 and Q703 turn off when the MAKO IC drives the FET_ENX pin high).

3.1.3 General

In the XTS 2500/XTS 2500I radio, power (B+) is distributed to one board that contains both the transceiver and controller sections. There is an additional backup battery (Motorola part number 6003710K08) mounted directly on the board; see the basic service manual for details.

Power for the radio is provided through a battery supplying a nominal 7.5Vdc directly to the transceiver. The battery is available in the following forms:

- NTN9815_ Nickel-Cadmium, Hi Capacity
- NTN9816_ Nickel-Cadmium, Hi Capacity, FM Approved
- NNTN9857_ Jedray NiMH Impres Standard Battery
- NNTN9858_ Jedray NiMH Impres FM Battery
- NNTN6263_ Jedray NiMH Impres FM Immersible Battery

B+ from the battery is electrically switched to most of the radio, rather than routed through the ON/OFF/Volume control knob, S501. The electrical switching of B+ supports a “keep-alive” mode. Under software control, even when the ON/OFF/Volume control knob has been turned to the “off” position, power remains on until the MCU completes its power-down, at which time the radio is physically powered-down.

3.1.4 B+ Routing for VHF Band Main Board

Refer to [Figure 3.1-1](#) and the appropriate schematic diagram in the back of this manual.

Raw B+ (7.5V) from the battery enters the radio through a 3-contact connector (B500). From B500 it is routed through a ferrite bead (E500) to the fuse (F500) where RAW_B+ is distributed to the transmitter and the RF section is supplied by RFSW_B+.

UNSW_B+ provides power to the following:

- the mechanical switch (S501)
- the radio's LED (D501)
- the voltage regulator (U503), which charges the lithium battery

and the voltage regulator (U702); then routes through the connector (J601, pin 3). U702 will be discussed in the B+ and +5V routing for the voice encoder (vocoder) and controller (VOCON) section.

During the transmit mode, UNSW_B+ routes through a ferrite bead (E101) to the Power Control IC (PCIC) (U102), the RF driver (U101), through another ferrite bead (E102) to the final power amplifier (Q101). UNSW_B+ also routes through the Field Effect Transistor (FET) switch (Q702) where it becomes SW_B+. SW_B+ powers a 5V linear regulator (U500), which supplies 5V to the PCIC (U102).

During the receive mode, the linear regular (U500) provides 5V to the mixer (U1) and the ABACUS III IC (U401). U500 also provides 5V to the Frequency Generation Unit's (FGU) FracN (U201) and VCOs.

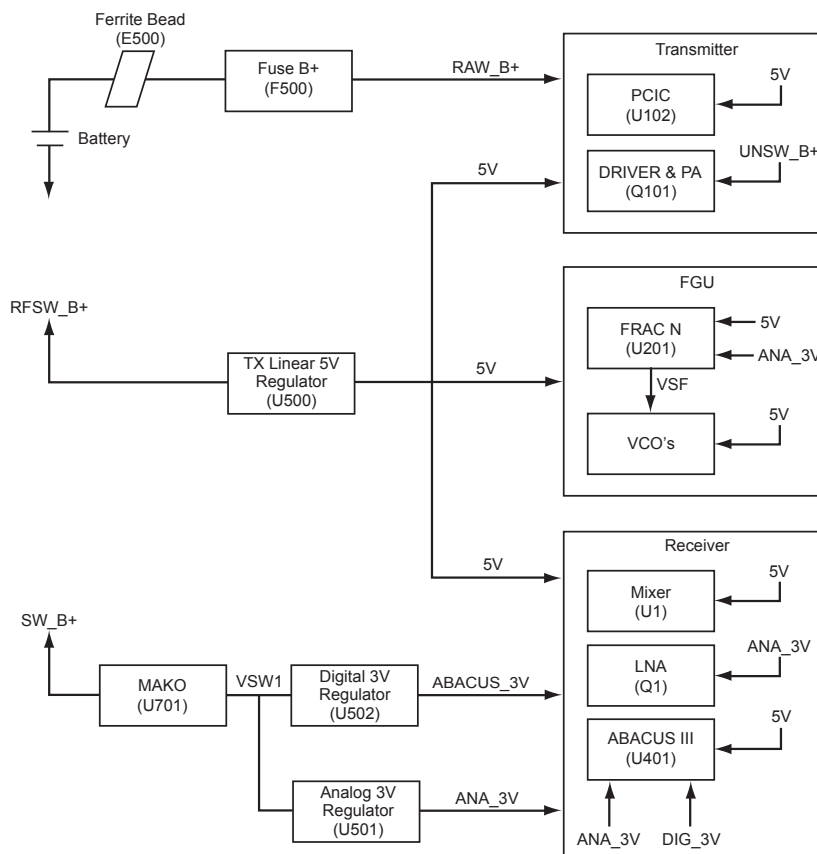

Figure 3.1-1. B+ Routing for VHF Main Board

3.1.5 B+ and +5V Routing for VOCON

Refer to [Figure 3.1-2](#) and the appropriate schematic diagrams in the back of this manual.

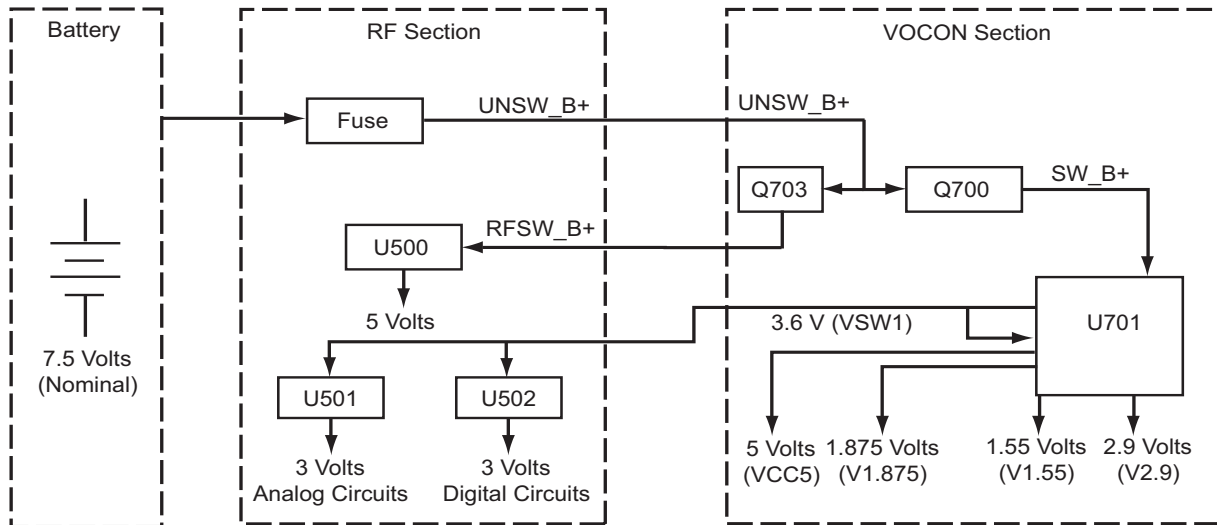

Figure 3.1-2. XTS 2500/XTS 2500I DC Distribution (for all other kits)

Power for the radio is derived from a 7.5 volt battery (UNSW_B+), which is applied to the power mosfet (Q703 and Q700) in the RF and VOCON sections respectively.

Q700 is a power mosfet switch that provides SW_B+ to the MAKO IC to U500 (the 5V regulator) in the RF section.

The digital circuits in the VOCON section are powered from regulators located in the MAKO IC. The MAKO IC provides five software-programmable supplies (VSW1, V1.55, V1.875, V2.9 and VCC5). VSW1 provides voltage to the 3V regulators (U501 and U502) in the RF section. The initial and programmed output of VSW2 (C715) is 2.3V. The VSW2 is used internal to the MAKO IC to supply the 1.875V (V1.875) and 1.55V (V1.55) linear voltage regulators.

Table 3.1-1 lists the supply voltages and the circuits that use these voltages.

Table 3.1-1. Power Supply Configuration for VOCON Section

Supply Name	Output Voltage	Supply Type	Unprogrammed Output Voltage	Circuits Supplied
UNSW_B+	6V - 9V 7.5V (nominal)	Battery	N/A	<ul style="list-style-type: none"> • Mechanical Switch • Power Switch • Secure Mode
SW_B+ RFSW_B+	6V - 9V 7.5 (nominal)	Battery	N/A	<ul style="list-style-type: none"> • VSW1Driver • Audio Power Amplifier • DC Power Supply to RF section • MAKO IC • Secure Module
VCC5	5V	Switching regulator software programmable	N/A	<ul style="list-style-type: none"> • Smart battery circuitry • Int./Ext. MIC Bias • Display LEDs
VSW1	3.6V	Switching regulator Software programmable	N/A	<ul style="list-style-type: none"> • 3V regulators (RF) • MAKO VSW2 Input
V1.875	1.875V dc	Switching regulator Software programmable	1.75V dc	<ul style="list-style-type: none"> • Dual-core processor's external memory interface • FLASH IC • SRAM
V1.55	1.55V dc	Switching regulator Software programmable	1.55V dc	<ul style="list-style-type: none"> • Dual-core processor core
V2.9	2.9V dc	Switching regulator Software programmable	2.775V dc	<ul style="list-style-type: none"> • Dual-core processor's I/O ring • Digital support circuitry • Display • 16.8MHz buffer • 32.768kHz buffer

Chapter 3.2 UHF1 Radio Power

3.2.1 Introduction

This chapter of the manual provides a detailed circuit description of the power distribution for an ASTRO XTS 2500/XTS 2500I digital portable radio. This manual is to be used in conjunction with the ASTRO XTS 2500/XTS 2500I Digital Portable Radios Basic Service Manual (Motorola part number 6816984H01), which uses the pass/fail service approach to radio problems.

3.2.2 Radio Power Up or Down

Radio power up begins when the radio ON/OFF/Volume control knob is turned to the on position, placing 7.5 volts on the MECH_SW line. This signal activates the pass element (Q700, Q701 and Q703), enabling SW_B+ and RFSW_B+.

The 7.5 Volts on the MECH_SW line turns Q701 ON, which in turn drives the MECH_SW pin on the MAKO IC (U701) low. With the high-low transition on the MECH_SW pin, the MAKO IC then pulls the FET_ENX pin (or VPP_EN line) low, enabling external P-MOSFETs Q700 and Q703. Q700 and Q703 applies SW_B+ to MAKO IC and VoCon and RF_SWB+ to the RF section of the board. After application of the power to SW_B+, the regulators VSW1, VSW2, V1.875, V1.55, V2.9 and VCC5 are sequentially turned ON. After the regulators are stable, the RESETX pin is asserted low for an additional 16ms and then released to allow the dual-core processor to start.

The radio power down sequence begins from the ON/OFF switch that disables Q701. This causes the MECH_SW pin on the MAKO IC to be pulled High. Then, the INT_X pin (or MAKO_INT) is drawn low and the 125ms Watchdog timer is started. The dual core processor (through SPI communication busses) then initiates the powering down process of the radio. At this point, the watchdog timer can be kept alive by the dual-core processor (via the SPI bus) allowing for software cleanup. Upon expiration of the watchdog timer, the MAKO IC asserts the RESETX pin and turns off all DC regulators including SW_B+ and RF_SWB+ (Q700 and Q703 turn off when the MAKO IC drives the FET_ENX pin high).

3.2.3 General

In the XTS 2500/XTS 2500I radio, power (B+) is distributed to one board that contains both the transceiver and controller sections. There is an additional backup battery (Motorola part number 6003710K08) mounted directly on the board; see the basic service manual for details.

Power for the radio is provided through a battery supplying a nominal 7.5Vdc directly to the transceiver. The battery is available in the following forms:

- NTN9815_ Nickel-Cadmium, Hi Capacity
- NTN9816_ Nickel-Cadmium, Hi Capacity, FM Approved
- NNTN9857_ Jedray NiMH Impres Standard Battery
- NNTN9858_ Jedray NiMH Impres FM Battery
- NNTN6263_ Jedray NiMH Impres FM Immersible Battery

B+ from the battery is electrically switched to most of the radio, rather than routed through the ON/OFF/Volume control knob, S501. The electrical switching of B+ supports a “keep-alive” mode. Under software control, even though the ON/OFF/Volume control knob has been turned to the “off” position, power remains on until the MCU completes its power-down sequence.

3.2.4 B+ Main Board Routing

Refer to [Figure 3.2-1](#) and the appropriate schematic diagram in the back of this manual.

Raw B+ (7.5V) from the battery enters the radio through a 3-contact connector (B500). UNSW_B+ (through fuse F500), RAW_B+ and mechanical switch S501 derives power from it.

Through fuse F500, UNSW_B+ supplies to MAKO BAT_7V5 pin, MAKO BPLUS (PA CODEC block) pin, Q700 and Q703. It is also routed to pin 3 of connector J601.

During the transmit mode, RAW_B+ feeds to U101 PA Driver, Q101 Final PA and U102 Power Control IC.

During the receive mode, the linear regulator (U500) provides 5V to the mixer (U1) and the ABACUS III IC (U401). U500 also provides 5V to the Frequency Generation Unit's (FGU) FracN (U201).

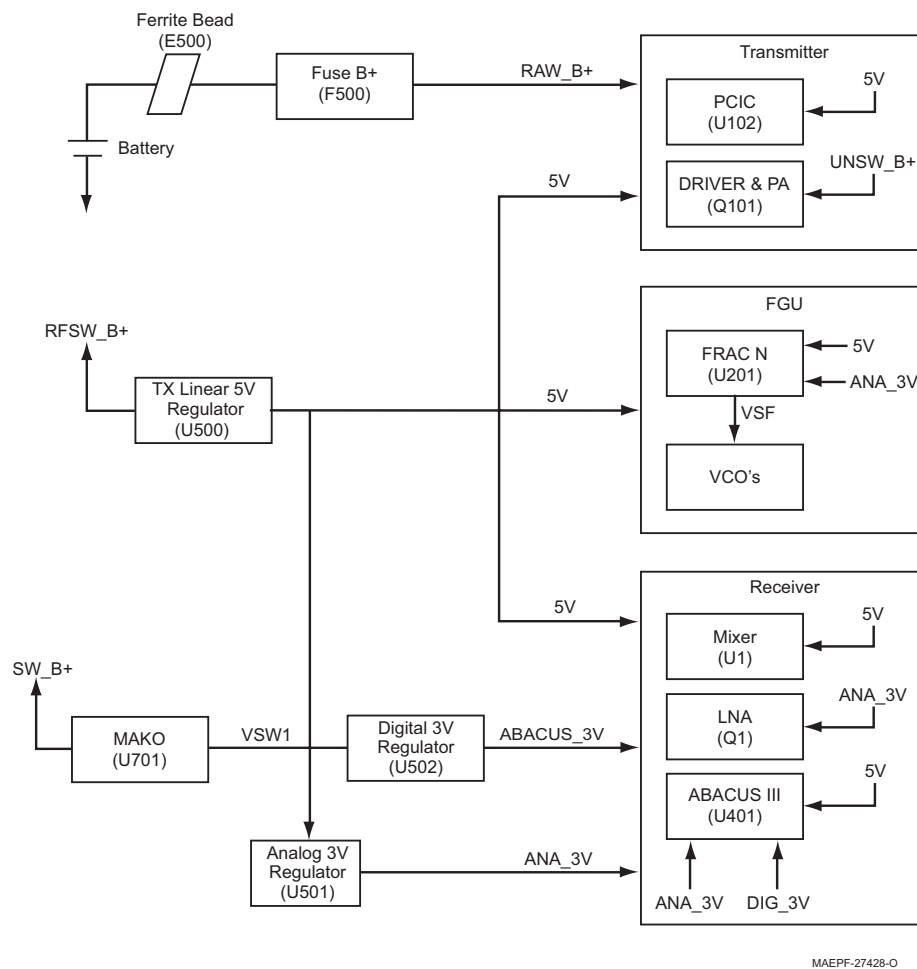

Figure 3.2-1. B+ Routing for Main Board

3.2.5 B+ and +5V Routing for VOCON

Refer to [Figure 3.2-2](#) and the appropriate schematic diagrams in the back of this manual.

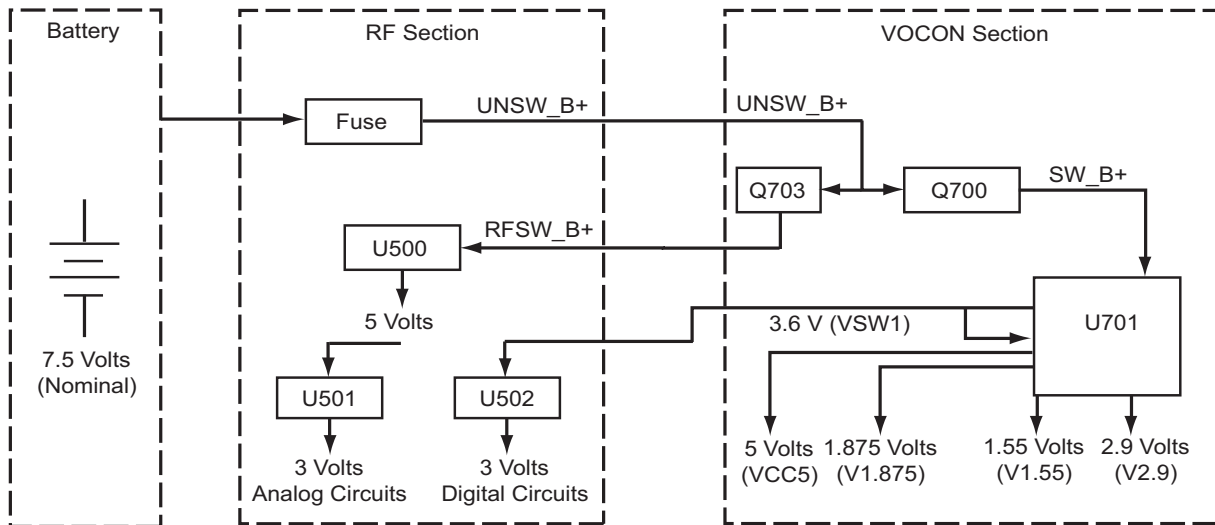

Figure 3.2-2. XTS 2500/XTS 2500I DC Distribution (for all other kits)

Power for the radio is derived from a 7.5 volt battery (UNSW_B+), which is applied to the power mosfet (Q703 and Q700) in the RF and VOCON sections respectively.

Q700 is a power mosfet switch that provides SW_B+ to the MAKO IC to U500 (the 5V regulator) in the RF section.

The digital circuits in the VOCON section are powered from regulators located in the MAKO IC. The MAKO IC provides five software-programmable supplies (VSW1, V1.55, V1.875, V2.9 and VCC5). VSW1 provides voltage to U502 that regulates 3 Volts to digital circuits, while U500 supplies to U501 that power analog circuits with 3 Volts in the RF section. The initial and programmed output of VSW2 (C715) is 2.3V. The VSW2 is used internal to the MAKO IC to supply the 1.875V (V1.875) and 1.55V (V1.55) linear voltage regulators.

Table 3.2-1 lists the supply voltages and the circuits that use these voltages.

Table 3.2-1. Power Supply Configuration for VOCON Section

Supply Name	Output Voltage	Supply Type	Unprogrammed Output Voltage	Circuits Supplied
UNSW_B+	6V - 9V 7.5V (nominal)	Battery	N/A	<ul style="list-style-type: none"> • Mechanical Switch • Power Switch • Secure Mode
SW_B+ RFSW_B+	6V - 9V 7.5 (nominal)	Battery	N/A	<ul style="list-style-type: none"> • VSW1Driver • Audio Power Amplifier • DC Power Supply to RF section • MAKO IC • Secure Module
VCC5	5V	Switching regulator software programmable	N/A	<ul style="list-style-type: none"> • Smart battery circuitry • Int./Ext. MIC Bias • Display LEDs
VSW1	3.6V	Switching regulator Software programmable	N/A	<ul style="list-style-type: none"> • 3V regulators (RF) • MAKO VSW2 Input
V1.875	1.875V dc	Switching regulator Software programmable	1.75V dc	<ul style="list-style-type: none"> • Dual-core processor's external memory interface • FLASH IC • SRAM
V1.55	1.55V dc	Switching regulator Software programmable	1.55V dc	<ul style="list-style-type: none"> • Dual-core processor core
V2.9	2.9V dc	Switching regulator Software programmable	2.775V dc	<ul style="list-style-type: none"> • Dual-core processor's I/O ring • Digital support circuitry • Display • 16.8MHz buffer • 32.768kHz buffer

Chapter 3.3 UHF2 Radio Power

3.3.1 Introduction

This chapter of the manual provides a detailed circuit description of the power distribution for an ASTRO XTS 2500/XTS 2500I digital portable radio. This manual is to be used in conjunction with the ASTRO XTS 2500/XTS 2500I Digital Portable Radios Basic Service Manual (Motorola part number 6816984H01), which uses the pass/fail service approach to radio problems.

3.3.2 Radio Power Up or Down

Radio power up begins when the radio ON/OFF/Volume control knob is turned to the on position, placing 7.5 volts on the MECH_SW line. This signal activates the pass element (Q700, Q701 and Q703), enabling SW_B+ and RFSW_B+.

The 7.5 Volts on the MECH_SW line turns Q701 ON, which in turn drives the MECH_SW pin on the MAKO IC (U701) low. With the high-low transition on the MECH_SW pin, the MAKO IC then pulls the FET_ENX pin (or VPP_EN line) low, enabling external P-MOSFETs Q700 and Q703. Q700 and Q703 applies SW_B+ to MAKO IC and VoCon and RF_SWB+ to the RF section of the board. After application of the power to SW_B+, the regulators VSW1, VSW2, V1.875, V1.55, V2.9 and VCC5 are sequentially turned ON. After the regulators are stable, the RESETX pin is asserted low for an additional 16ms and then released to allow the dual-core processor to start.

The radio power down sequence begins from the ON/OFF switch that disables Q701. This causes the MECH_SW pin on the MAKO IC to be pulled High. Then, the INT_X pin (or MAKO_INT) is drawn low and the 125ms Watchdog timer is started. The dual core processor (through SPI communication busses) then initiates the powering down process of the radio. At this point, the watchdog timer can be kept alive by the dual-core processor (via the SPI bus) allowing for software cleanup. Upon expiration of the watchdog timer, the MAKO IC asserts the RESETX pin and turns off all DC regulators including SW_B+ and RF_SWB+ (Q700 and Q703 turn off when the MAKO IC drives the FET_ENX pin high).

3.3.3 General

In the XTS 2500/XTS 2500I radio, power (B+) is distributed to one board that contains both the transceiver and controller sections. There is an additional backup battery (Motorola part number 6003710K08) mounted directly on the board; see the basic service manual for details.

Power for the radio is provided through a battery supplying a nominal 7.5Vdc directly to the transceiver. The battery is available in the following forms:

- NTN9815_ Nickel-Cadmium, Hi Capacity
- NTN9816_ Nickel-Cadmium, Hi Capacity, FM Approved
- NNTN9857_ Jedray NiMH Impres Standard Battery
- NNTN9858_ Jedray NiMH Impres FM Battery
- NNTN6263_ Jedray NiMH Impres FM Immersible Battery

B+ from the battery is electrically switched to most of the radio, rather than routed through the ON/OFF/Volume control knob, S501. The electrical switching of B+ supports a “keep-alive” mode. Under software control, even though the ON/OFF/Volume control knob has been turned to the “off” position, power remains on until the MCU completes its power-down sequence.

3.3.4 B+ Routing for UHF2 Band Main Board

Refer to [Figure 3.3-1](#) and the appropriate schematic diagram in the back of this manual.

Raw B+ (7.5V) from the battery enters the radio through a 3-contact connector (B500). UNSW_B+ (through fuse F500), RAW_B+ and mechanical switch S501 derives power from it.

Through fuse F500, UNSW_B+ supplies to MAKO BAT_7V5 pin, MAKO BPLUS (PA CODEC block) pin, Q700 and Q703. It is also routed to pin 3 of connector J601.

During the transmit mode, RAW_B+ feeds to U101 PA Driver, Q101 Final PA and U102 Power Control IC.

During the receive mode, the linear regulator (U500) provides 5V to the mixer (U1) and the ABACUS III IC (U401). U500 also provides 5V to the Frequency Generation Unit's (FGU) FracN (U201).

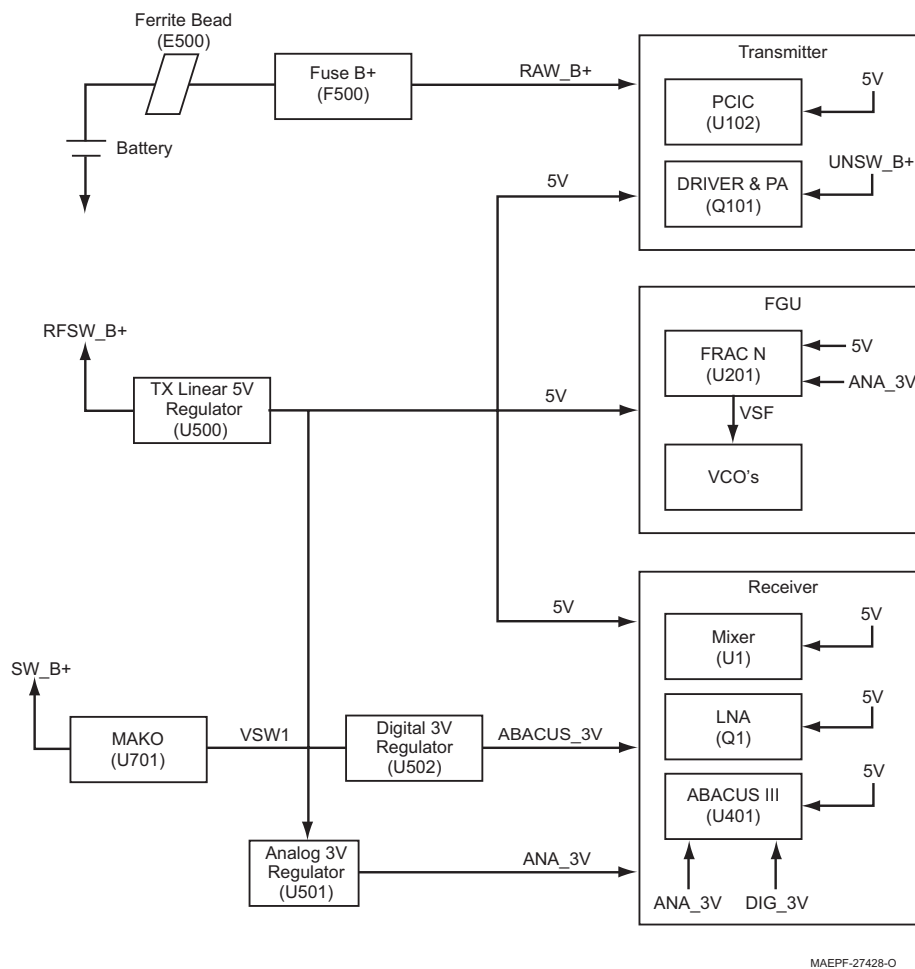

Figure 3.3-1. B+ Routing for Main Board

3.3.5 B+ and +5V Routing for VOCON

Refer to [Figure 3.3-2](#) and the appropriate schematic diagrams in the back of this manual.

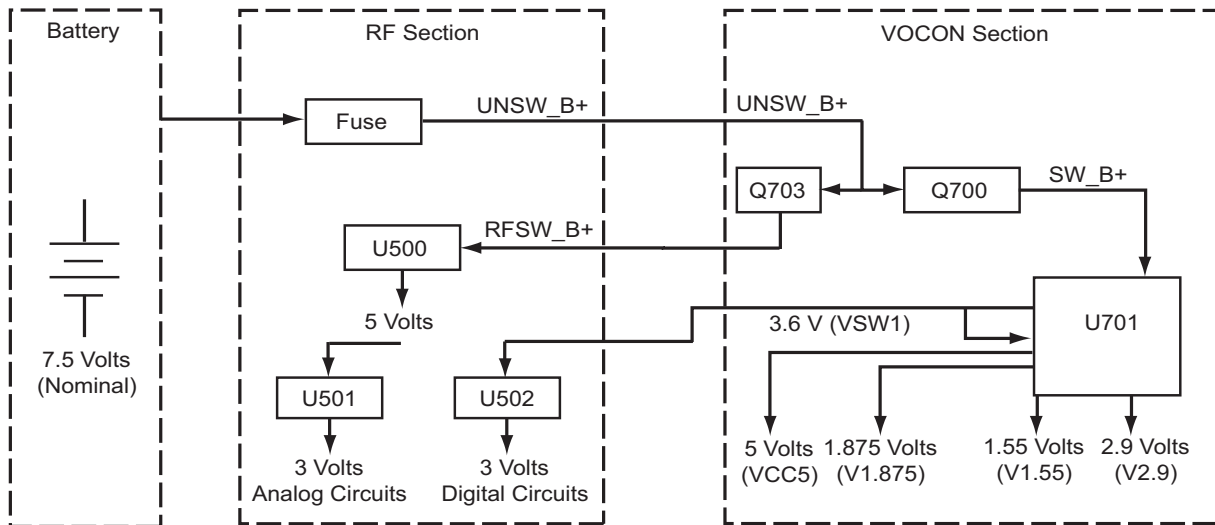

Figure 3.3-2. XTS 2500/XTS 2500I DC Distribution (for all other kits)

Power for the radio is derived from a 7.5 volt battery (UNSW_B+), which is applied to the power mosfet (Q703 and Q700) in the RF and VOCON sections respectively.

Q700 is a power mosfet switch that provides SW_B+ to the MAKO IC to U500 (the 5V regulator) in the RF section.

The digital circuits in the VOCON section are powered from regulators located in the MAKO IC. The MAKO IC provides five software-programmable supplies (VSW1, V1.55, V1.875, V2.9 and VCC5). VSW1 provides voltage to U502 that regulates 3 Volts to digital circuits, while U500 supplies to U501 that power analog circuits with 3 Volts in the RF section. The initial and programmed output of VSW2 (C715) is 2.3V. The VSW2 is used internal to the MAKO IC to supply the 1.875V (V1.875) and 1.55V (V1.55) linear voltage regulators.

Table 3.3-1 lists the supply voltages and the circuits that use these voltages.

Table 3.3-1. Power Supply Configuration for VOCON Section

Supply Name	Output Voltage	Supply Type	Unprogrammed Output Voltage	Circuits Supplied
UNSW_B+	6V - 9V 7.5V (nominal)	Battery	N/A	<ul style="list-style-type: none"> • Mechanical Switch • Power Switch • Secure Mode
SW_B+ RFSW_B+	6V - 9V 7.5 (nominal)	Battery	N/A	<ul style="list-style-type: none"> • VSW1Driver • Audio Power Amplifier • DC Power Supply to RF section • MAKO IC • Secure Module
VCC5	5V	Switching regulator software programmable	N/A	<ul style="list-style-type: none"> • Smart battery circuitry • Int./Ext. MIC Bias • Display LEDs
VSW1	3.6V	Switching regulator Software programmable	N/A	<ul style="list-style-type: none"> • 3V regulators (RF) • MAKO VSW2 Input
V1.875	1.875V dc	Switching regulator Software programmable	1.75V dc	<ul style="list-style-type: none"> • Dual-core processor's external memory interface • FLASH IC • SRAM
V1.55	1.55V dc	Switching regulator Software programmable	1.55V dc	<ul style="list-style-type: none"> • Dual-core processor core
V2.9	2.9V dc	Switching regulator Software programmable	2.775V dc	<ul style="list-style-type: none"> • Dual-core processor's I/O ring • Digital support circuitry • Display • 16.8MHz buffer • 32.768kHz buffer

Chapter 3.4 700/800 MHz Radio Power

3.4.1 Introduction

This chapter of the manual provides a detailed circuit description of the power distribution for an ASTRO XTS 2500/XTS 2500I digital portable radio. This manual is to be used in conjunction with the ASTRO XTS 2500/XTS 2500I Digital Portable Radios Basic Service Manual (Motorola part number 6816984H01), which uses the pass/fail service approach to radio problems.

3.4.2 Radio Power Up or Down

Radio power up begins when the radio ON/OFF/Volume control knob is turned to the on position, placing 7.5 volts on the MECH_SW line. This signal activates the pass element (Q700, Q701 and Q703), enabling SW_B+ and RFSW_B+.

When the MAKO IC (U701) detects a low to high voltage transition on the MECH_SW pin, it grounds the FET_ENX pin (or VPP_EN) driving the gate of an external P-MOSFET (Q700 and Q703) low. This turns ON the transistors Q700 and Q703 and applies SW_B+ to MAKO IC and VoCon and RF_SWB+ to the RF section of the board. After application of the power to SW_B+, the regulators VSW1, VSW2, V1.875, V1.55, V2.9 and VCC5 are sequenced on. After the regulators are stable, the RESETX pin is asserted low for an additional 16ms and then de-asserted allowing the dual-core processor to start.

The radio power down sequence begins by opening the radio ON/OFF switch, causing the MECH_SW pin to transition high. This causes the MAKO IC to start an internal 125ms watchdog timer and drive the INT_X pin (or MAKO_INT) interrupt output pin low. The dual-core processor then determines (through communication on the SPI bus) that it must initiate the power-down sequence. At this point, the watchdog timer can be kept alive by the dual-core processor (via the SPI bus) allowing for software cleanup. Upon expiration of the watchdog timer, the MAKO IC asserts the RESETX pin and turns off all DC regulators including SW_B+ and RF_SWB+ (Q700 and Q703 turn off when the MAKO IC drives the FET_ENX pin high).

3.4.3 General

In the XTS 2500/XTS 2500I radio, power (B+) is distributed to one board that contains both the transceiver and controller sections. There is an additional backup battery (Motorola part number 6003710K08) mounted directly on the board; see the basic service manual for details.

Power for the radio is provided through a battery supplying a nominal 7.5Vdc directly to the transceiver. The battery is available in the following forms:

- NTN9815_ Nickel-Cadmium, Hi Capacity
- NTN9816_ Nickel-Cadmium, Hi Capacity, FM Approved
- NNTN9857_ Jedray NiMH Impres Standard Battery
- NNTN9858_ Jedray NiMH Impres FM Battery
- NNTN6263_ Jedray NiMH Impres FM Immersible Battery

B+ from the battery is electrically switched to most of the radio, rather than routed through the ON/OFF/Volume control knob, S501. The electrical switching of B+ supports a “keep-alive” mode. Under software control, even when the ON/OFF/Volume control knob has been turned to the “off” position, power remains on until the MCU completes its power-down, at which time the radio is physically powered-down.

3.4.4 B+ Routing for 700/800 MHz Band Main Board

Refer to [Figure 3.4-1](#) and the appropriate schematic diagram in the back of this manual.

Raw B+ (7.5V) from the battery enters the radio through a 3-contact connector (B500). From B500 it is routed through a ferrite bead (E500) to the fuse (F500) where RAW_B+ is distributed to the transmitter and the RF section is supplied by RFSW_B+.

UNSW_B+ provides power to the following:

- the mechanical switch (S501)
- the radio's LED (D501)

and the voltage regulator (U702); then routes through the connector (J601, pin 3). U702 will be discussed in the B+ and +5V routing for the voice encoder (vocoder) and controller (VOCON) section.

During the transmit mode, UNSW_B+ routes through a ferrite bead (E101) to the Power Control IC (PCIC) (U102), the RF driver (U101), through another ferrite bead (E102) to the final power amplifier (Q101). UNSW_B+ also routes through the Field Effect Transistor (FET) switch (Q702) where it becomes SW_B+. SW_B+ powers a 5V linear regulator (U500), which supplies 5V to the PCIC (U102).

During the receive mode, the linear regulator (U500) provides 5V to the mixer (U1) and the ABACUS III IC (U401). U500 also provides 5V to the Frequency Generation Unit's (FGU) FracN (U201) and VCOs.

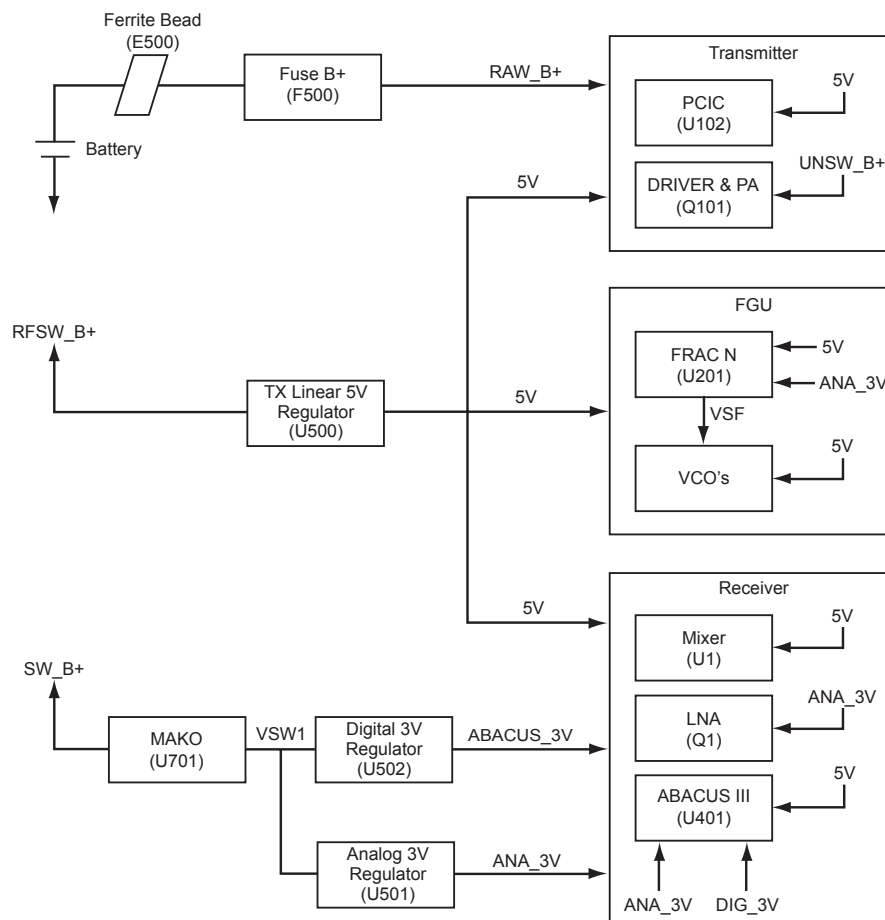

Figure 3.4-1. B+ Routing for 700/800 MHz Main Board

3.4.5 B+ and +5V Routing for VOCON

Refer to [Figure 3.4-2](#) and the appropriate schematic diagrams in the back of this manual.

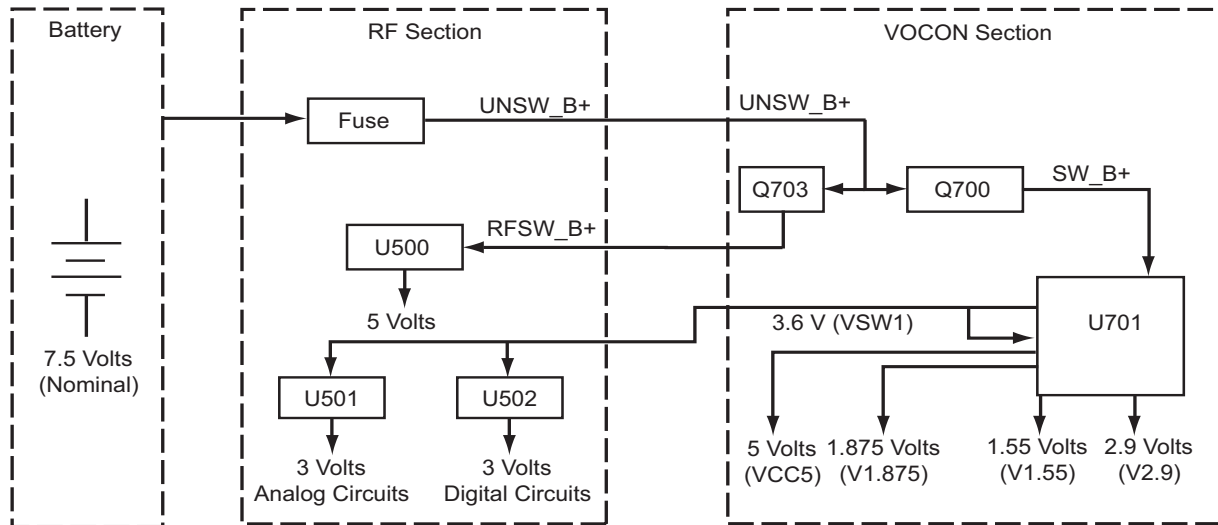

Figure 3.4-2. XTS 2500/XTS 2500I DC Distribution (for all other kits)

Power for the radio is derived from a 7.5 volt battery (UNSW_B+), which is applied to the power mosfet (Q703 and Q700) in the RF and VOCON sections respectively.

Q700 is a power mosfet switch that provides SW_B+ to the MAKO IC to U500 (the 5V regulator) in the RF section.

The digital circuits in the VOCON section are powered from regulators located in the MAKO IC. The MAKO IC provides five software-programmable supplies (VSW1, V1.55, V1.875, V2.9 and VCC5). VSW1 provides voltage to the 3V regulators (U501 and U502) in the RF section. The initial and programmed output of VSW2 (C715) is 2.3V. The VSW2 is used internal to the MAKO IC to supply the 1.875V (V1.875) and 1.55V (V1.55) linear voltage regulators.

Table 3.4-1 lists the supply voltages and the circuits that use these voltages.

Table 3.4-1. Power Supply Configuration for VOCON Section

Supply Name	Output Voltage	Supply Type	Unprogrammed Output Voltage	Circuits Supplied
UNSW_B+	6V - 9V 7.5V (nominal)	Battery	N/A	<ul style="list-style-type: none"> • Mechanical Switch • Power Switch • Secure Mode
SW_B+ RFSW_B+	6V - 9V 7.5 (nominal)	Battery	N/A	<ul style="list-style-type: none"> • VSW1Driver • Audio Power Amplifier • DC Power Supply to RF section • MAKO IC • Secure Module
VCC5	5V	Switching regulator software programmable	N/A	<ul style="list-style-type: none"> • Smart battery circuitry • Int./Ext. MIC Bias • Display LEDs
VSW1	3.6V	Switching regulator Software programmable	N/A	<ul style="list-style-type: none"> • 3V regulators (RF) • MAKO VSW2 Input
V1.875	1.875V dc	Switching regulator Software programmable	1.75V dc	<ul style="list-style-type: none"> • Dual-core processor's external memory interface • FLASH IC • SRAM
V1.55	1.55V dc	Switching regulator Software programmable	1.55V dc	<ul style="list-style-type: none"> • Dual-core processor core
V2.9	2.9V dc	Switching regulator Software programmable	2.775V dc	<ul style="list-style-type: none"> • Dual-core processor's I/O ring • Digital support circuitry • Display • 16.8MHz buffer • 32.768kHz buffer

Chapter 3.5 900 MHz Radio Power

3.5.1 Introduction

This chapter of the manual provides a detailed circuit description of the power distribution for an ASTRO XTS 2500/XTS 2500I digital portable radio. This manual is to be used in conjunction with the ASTRO XTS 2500/XTS 2500I Digital Portable Radios Basic Service Manual (Motorola part number 6816984H01), which uses the pass/fail service approach to radio problems.

3.5.2 Radio Power Up or Down

Radio power up begins when the radio ON/OFF/Volume control knob is turned to the on position, placing 7.5 volts on the MECH_SW line. This signal activates the pass element (Q700, Q701 and Q703), enabling SW_B+ and RFSW_B+.

When the MAKO IC (U701) detects a low to high voltage transition on the MECH_SW pin, it grounds the FET_ENX pin (or VPP_EN) driving the gate of an external P-MOSFET (Q700 and Q703) low. This turns ON the transistors Q700 and Q703 and applies SW_B+ to MAKO IC and VoCon and RF_SWB+ to the RF section of the board. After application of the power to SW_B+, the regulators VSW1, VSW2, V1.875, V1.55, V2.9 and VCC5 are sequenced on. After the regulators are stable, the RESETX pin is asserted low for an additional 16ms and then de-asserted allowing the dual-core processor to start.

The radio power down sequence begins by opening the radio ON/OFF switch, causing the MECH_SW pin to transition high. This causes the MAKO IC to start an internal 125ms watchdog timer and drive the INT_X pin (or MAKO_INT) interrupt output pin low. The dual-core processor then determines (through communication on the SPI bus) that it must initiate the power-down sequence. At this point, the watchdog timer can be kept alive by the dual-core processor (via the SPI bus) allowing for software cleanup. Upon expiration of the watchdog timer, the MAKO IC asserts the RESETX pin and turns off all DC regulators including SW_B+ and RF_SWB+ (Q700 and Q703 turn off when the MAKO IC drives the FET_ENX pin high).

3.5.3 General

In the XTS 2500/XTS 2500I radio, power (B+) is distributed to one board that contains both the transceiver and controller sections. There is an additional backup battery (Motorola part number 6003710K08) mounted directly on the board; see the basic service manual for details.

Power for the radio is provided through a battery supplying a nominal 7.5Vdc directly to the transceiver. The battery is available in the following forms:

- NTN9815_ Nickel-Cadmium, Hi Capacity
- NTN9816_ Nickel-Cadmium, Hi Capacity, FM Approved
- NNTN9857_ Jedray NiMH Impres Standard Battery
- NNTN9858_ Jedray NiMH Impres FM Battery

B+ from the battery is electrically switched to most of the radio, rather than routed through the ON/OFF/Volume control knob, S501. The electrical switching of B+ supports a “keep-alive” mode. Under software control, even when the ON/OFF/Volume control knob has been turned to the “off” position, power remains on until the MCU completes its power-down, at which time the radio is physically powered-down.

3.5.4 B+ Routing for 900 MHz Band Main Board

Refer to [Figure 3.5-1](#) and the appropriate schematic diagram in the back of this manual.

Raw B+ (7.5V) from the battery enters the radio through a 3-contact connector (B500). From B500 it is routed through a ferrite bead (E500) to the fuse (F500) where RAW_B+ is distributed to the transmitter and the RF section is supplied by RFSW_B+.

UNSW_B+ provides power to the following:

- the mechanical switch (S501)
- the radio's LED (D501)

and the voltage regulator (U702); then routes through the connector (J601, pin 3). U702 will be discussed in the B+ and +5V routing for the voice encoder (vocoder) and controller (VOCON) section.

During the transmit mode, UNSW_B+ routes through a ferrite bead (E101) to the Power Control IC (PCIC) (U102), the RF driver (U101), through another ferrite bead (E102) to the final power amplifier (Q101). UNSW_B+ also routes through the Field Effect Transistor (FET) switch (Q702) where it becomes SW_B+. SW_B+ powers a 5V linear regulator (U500), which supplies 5V to the PCIC (U102).

During the receive mode, the linear regular (U500) provides 5V to the mixer (U1) and the ABACUS III IC (U401). U500 also provides 5V to the Frequency Generation Unit's (FGU) FracN (U201) and VCOs.

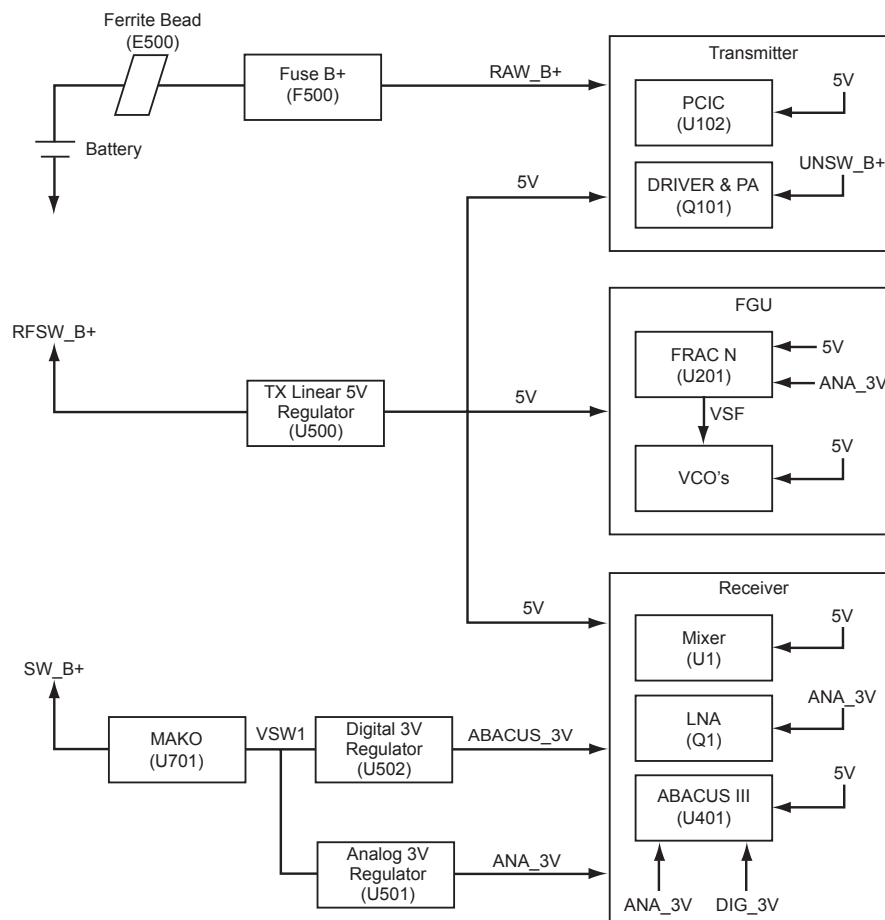

Figure 3.5-1. B+ Routing for 900MHz Main Board

3.5.5 B+ and +5V Routing for VOCON

Refer to [Figure 3.5-2](#) and the appropriate schematic diagrams in the back of this manual.

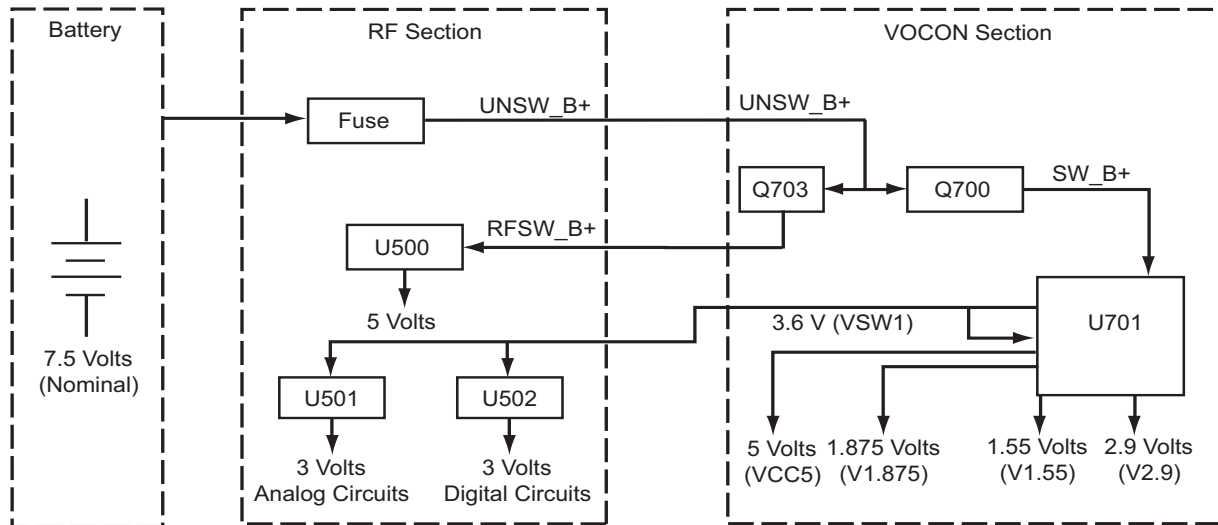

Figure 3.5-2. XTS 2500/XTS 2500I DC Distribution (for all other kits)

Power for the radio is derived from a 7.5 volt battery (UNSW_B+), which is applied to the power mosfet (Q703 and Q700) in the RF and VOCON sections respectively.

Q700 is a power mosfet switch that provides SW_B+ to the MAKO IC to U500 (the 5V regulator) in the RF section.

The digital circuits in the VOCON section are powered from regulators located in the MAKO IC. The MAKO IC provides five software-programmable supplies (VSW1, V1.55, V1.875, V2.9 and VCC5). VSW1 provides voltage to the 3V regulators (U501 and U502) in the RF section. The initial and programmed output of VSW2 (C715) is 2.3V. The VSW2 is used internal to the MAKO IC to supply the 1.875V (V1.875) and 1.55V (V1.55) linear voltage regulators.

Table 3.5-1 lists the supply voltages and the circuits that use these voltages.

Table 3.5-1. Power Supply Configuration for VOCON Section

Supply Name	Output Voltage	Supply Type	Unprogrammed Output Voltage	Circuits Supplied
UNSW_B+	6V - 9V 7.5V (nominal)	Battery	N/A	<ul style="list-style-type: none"> • Mechanical Switch • Power Switch • Secure Mode
SW_B+ RFSW_B+	6V - 9V 7.5 (nominal)	Battery	N/A	<ul style="list-style-type: none"> • VSW1Driver • Audio Power Amplifier • DC Power Supply to RF section • MAKO IC • Secure Module
VCC5	5V	Switching regulator software programmable	N/A	<ul style="list-style-type: none"> • Smart battery circuitry • Int./Ext. MIC Bias • Display LEDs
VSW1	3.6V	Switching regulator Software programmable	N/A	<ul style="list-style-type: none"> • 3V regulators (RF) • MAKO VSW2 Input
V1.875	1.875V dc	Switching regulator Software programmable	1.75V dc	<ul style="list-style-type: none"> • Dual-core processor's external memory interface • FLASH IC • SRAM
V1.55	1.55V dc	Switching regulator Software programmable	1.55V dc	<ul style="list-style-type: none"> • Dual-core processor core
V2.9	2.9V dc	Switching regulator Software programmable	2.775V dc	<ul style="list-style-type: none"> • Dual-core processor's I/O ring • Digital support circuitry • Display • 16.8MHz buffer • 32.768kHz buffer

Chapter 4.1 VHF Detailed Theories of Operation

4.1.1 Introduction

This chapter provides a detailed circuit description of the ASTRO XTS 2500/XTS 2500I/XTS 2250/XTS 1500 radio board. When reading the theory of operation, refer to the appropriate schematic and component location diagrams located in the back of this manual. This detailed theory of operation can help isolate the problem to a particular component.

This manual is to be used in conjunction with the ASTRO XTS 2500, XTS 2500I, XTS 2250, XTS 1500, MT 1500 Digital Portable Radios Basic Service Manual (Motorola part number 6816984H01), which uses the pass/fail service approach to radio problems.

4.1.2 Frequency Synthesis

The complete synthesizer subsystem consists of the following:

- The **reference oscillator** (Y200)
- Two **voltage-controlled oscillators** (TX and RX)
- One **voltage-controlled oscillator buffer IC** (U250)
- The **synthesizer** (U202)

The **reference oscillator** contains a temperature-compensated 16.8 MHz crystal. This oscillator is digitally tuned and contains a temperature-referenced, six-bit, analog-to-digital (A/D) converter. The output of the oscillator (pin 3 on Y200) is applied to pin K9 (XTAL1) of U202 through capacitor C214.

The **voltage-controlled oscillators** (VCOs) are varactor-tuned. The voltage (2–9.5V) varies as it is being applied to varactors D251 to D252 and D270 of their respective VCO. The capacitance of the varactors also varies, thereby changing the output frequency of the VCOs. Both VCOs are used to cover the entire 38 MHz bandwidth of the VHF range (136–174 MHz):

- TX VCO covers the transmit frequencies from 136–174 MHz
- RX VCO covers the receive frequencies from 180.85–218.85 MHz

The **TX and RX VCOs** are selected using AUX 3 from U202. Both VCOs are connected to the same prescaler filter (C292, C266, L266 and R266) feeding back to PREIN of the U202, through C293.

The **synthesizer** IC consists of the following:

- A prescaler
 - A programmable loop divider
 - A divider logic control
 - A phase detector
 - A charge pump
 - An A/D converter for low-frequency digital modulation
 - A balance attenuator to balance the high-frequency analog modulation to the low-frequency digital modulation
 - A 13V positive voltage multiplier
 - A serial interface for control
 - A filter for the regulated 5 and 3 volts
-

The 13V, being generated by the positive voltage multiplier circuitry, should be present at pin A2 of U202. The serial interface (SRL) is connected to the microprocessor via the data line (pin F1 of U202), the clock line (pin F4 of U202), and the chip-enable line (pin G1 of U202).

The complete synthesizer subsystem works as follows:

1. The buffered output of the VCO is present at R294 in receive mode and R275 during transmit mode.
2. The output of the prescaler filter is present at C293 and applied to pin D10 of U202. The prescaler in U202 is a dual-modulus type with selectable divider ratios. This divider ratio is controlled by the loop divider, which in turn receives its input from the SRL. The loop divider adds or subtracts phase to the prescaler divider by changing the divider ratio via the modulus control line.
3. The output of the prescaler is then applied to the loop divider.
4. The output of the loop divider then feeds the phase detector. The phase detector will compare the loop divider's output signal from the VCOs. The VCO signal is divided down after it is applied to pin D10 of U202. The result of the comparison is a pulsed DC signal which is applied to the charge pump.
5. The charge pump outputs a current that will be present at pin A5 of U202. The loop filter consisting of R202, C202, R203, C203, R201, C201, C236, C237, C238, C239 and C240 will convert this current into a voltage that will be applied to varactors D251, D252 and D270 to alter the output frequency of the VCO.

In order to modulate the PLL, the following two-port modulation method is utilized: The analog modulating signal is applied to (1) the A/D converter as well as to (2) the balance attenuator:

1. The A/D converter converts the low-frequency analog modulating signal into a digital code. When the digital code is applied to the loop divider, it causes the carrier to deviate.
2. The balance attenuator is used to adjust the VCO's deviation sensitivity to high-frequency modulating signals.

4.1.3 Antenna Switch

An electronic PIN diode switch steers RF between the receiver and transmitter. The common node of the switch is at capacitors C171 and C180 for VHF.

1. In transmit mode:
 - a. RF is routed to the anode of diode D170.
 - b. Bias current, sourced from RAW_B+ is routed through PIN diodes D170 and D171, biasing them to a low-impedance state.
2. In receive mode:
 - a. RF is routed through C179 to pre-selector filter.
 - b. PIN diodes D170 and D171 are unbiased and thus at high impedance.

4.1.4 Receiver

The receiver consists of the following:

- Front end
- Back end

4.1.4.1 Front End

For the purposes of this discussion, the receiver front end is defined as being the circuitry from the antenna switch to the output of the IF crystal filter. The VHF front end converts the received RF signal to the 1st IF frequency of 44.85 MHz, while at the same time providing for spurious immunity and adjacent channel selectivity. A review of the interstage components of the front end follows, with emphasis on troubleshooting considerations.

The received RF signal is passed through quarter wavelength components C180, L176, and C178, (which are anti-resonant at the radio's transmitter frequencies). Both PIN diodes D170 and D171 must be reverse biased to properly route the received RF signal.

Next is the varactor-tuned preselector filter made up of C1, C2, L5, D4, D3, L7, C9, D11, D10, L12, L8 and L16. The preselector is positioned right after the antenna switch to provide the receiver preamp with some protection against strong signal, out-of-band signals, and first-image suppression.

The stage following the preselector is a step attenuator (U2). This attenuator provides 15 dB step attenuation to protect the receiver from strong RF signals. The attenuator is controlled by a DSP-based algorithm that continuously monitors signal strength. When the ON threshold is exceeded (approximately -95 dBm), the attenuator is activated via a DAC in the PCIC by the host. The attenuator remains activated until the signal drops below the OFF threshold (approximately -115 dBm including the 15 dB attenuation). Hysteresis and timer functions are included in the algorithm to enhance performance. The algorithm controlling the attenuator is enabled via the CPS for each personality. When the algorithm is disabled, the attenuator is essentially a short circuit from input to output.

After the step attenuator, the received signal is applied to the **receiver preamp, Q29**. The preamp is a transistor, which has been biased and matched for optimum intermodulation (IM), noise figure (NF), and gain performance. Components L21 and C20 match the input of the amp to the step attenuator output. The preamp is supplied by a 5V analog regulator and is biased at approximately 0.75Vdc at the base and 2Vdc at the collector.

The output of the amp is matched to a second **two-pole preselector** filter of the type previously discussed. The match is via C35 and L31. The subsequent stage in the receiver chain is the **1st mixer U1**, which uses high-side injection, to convert the RF carrier to an intermediate frequency (IF) of 44.85 MHz. Since high-side injection is used, the LO frequency is offset above the RF carrier by 44.85 MHz, or $F_{LO} = F_{RF} + 44.85 \text{ MHz}$. The mixer utilizes GaAs technology in a double-balanced, Gilbert Cell configuration.

A balun transformer (T51) is used to couple the RF signal into the mixer. The primary winding of T51 is matched to the preceding stage by C62, C63, C64 and L61. The secondary winding of T51 provides a differential output. The center tap pin is grounded via an 100-ohm resistor that sets the mixer bias current. The differential signal is applied to the mixer through pin 4 and 5.

The final stage in the receiver front end is a **two-pole crystal filter (FL51)**. The crystal filter provides some of the receiver's adjacent channel selectivity and intermodulation. The crystal filter provides at least 75dB of second image protection and improves IM distortion in the ABACUS III IC.

4.1.4.2 Back End

In the **ABACUS IC (U401)**, the first IF frequency is amplified and then down-converted to the second IF frequency (2.25 MHz). At this point, the analog signal is converted into two digital bit streams by a sigma-delta A/D converter. The bit streams are then digitally filtered, mixed down to baseband, and filtered again. The output data stream is then sent to the Patriot IC, where it is decoded to produce the recovered audio.

The ABACUS IC (U401) is electronically programmable. The amount of filtering, which is dependent on the radio channel spacing and signal type, is controlled by the microcomputer. Additional filtering, which used to be provided externally by a conventional ceramic filter, is replaced by internal digital filters in the ABACUS IC.

The ABACUS IC contains a feedback Automatic Gain Control (AGC) circuit to expand the dynamic range of the sigma-delta converter. The differential output data contains the quadrature (I and Q) information in 16-bit words, the AGC information in a 9-bit word, imbedded word sync information, and fill bits. Two synthesizers are available on the chip for second LO and sampling clock (18 MHz) generation.

For VHF, the second LO/VCO is a Colpitts oscillator built around transistor Q401. Varactor diode (D402) in the VCO is used to adjust the VCO frequency. The control signal for the varactor is derived from a loop filter consisting of C440, R417, C441, R418, and C480. The sampling clock is derived from a negative resistance generator (on the chip) available at CLKP, CLKN, and an external tank circuit (L403, C423, and D401). The loop filter for the clock is realized by C448, R408, and C425.

4.1.5 Transmitter

The VHF RF power amplifier (PA) consists of

- an RF driver (**U101**) and
- a Silicon N-Channel MOSFET type transistor specifically designed for VHF RF power amplifier (**Q101**).

For VHF, an RF input drive level of approximately +3dBm is supplied from the VCO buffer IC (U250). This input drive level is applied to pin 16 (RFIN) of **U101**. The dc power is applied to pins 6, 7, and 14 of **U101** and to the drain of **Q101** via a filtered RAW_B+. Power control is achieved through the varying of the dc bias (and thus the gain) to pin 1 of **U101** and the gate of **Q101**. The amplified RF signal leaves the RF final PA (**Q101**) at the drain and is applied to the discrete directional coupler via an impedance match. The RF signal passes through the coupler, a discrete antenna switch, and a discrete harmonic filter before finally reaching the antenna launch connector.

A portion of the forward RF power is sampled by the directional coupler, applied to the diode (D172) for rectification, and the resulting dc signal is fed back to pin 1 of the Power Control IC (PCIC, U102). This dc signal is representative of the forward RF power being passed through the directional coupler. The dc signal is used by the PCIC to regulate the transmitted RF power level.

The PCIC is the heart of the power control loop. The rectified feedback is internally compared to an internal Digital-to-Analog Converter (DAC) output voltage in the PCIC to determine the amount of DC bias voltage at pin 4. This voltage at pin 4 of the PCIC controls the gain (and thus the output power, as explained above) of the RF driver (**U101**) and the RF power amplifier (**Q101**) via a fixed resistor divider network.

U103 senses the temperature of the printed circuit board (PCB) near the RF Power Amplifier (**Q101**) and provides a dc level representative of this temperature to pin 30 of the PCIC. The PCIC uses this input to cut back the output power level after a certain temperature threshold is reached. This ensures (1) radio integrity while transmitting in extreme ambient conditions hotter than the radio's operating temperature range and (2) acts as a safety feature to prevent any thermal runaway fault conditions.

Pin 32 of the PCIC powers the Temperature Sense IC (U103) and forward biases the antenna switch diodes (D170 and D171) while the radio is in transmit mode. This routes the RF signal from the transmitter to the antenna, as explained above. The antenna switch diodes are unbiased during receive and standby modes; therefore, any RF signal present at the antenna is applied to the receiver.

4.1.6 VOCON Functional Blocks

The three main functional blocks of the VOCON section consist of the following sections:

- the Controller and Memory Section, consisting of the following components:
 - the Patriot IC (U800)
 - the dual-core processor with the microcontroller unit (MCU) and a digital signal processor (DSP)
 - the SRAM IC (U804) and FLASH IC (U803) memory devices.
- the Audio and Power Section and digital support are all embedded into the MAKO IC (U701).
- the Interface Support Section, consisting of the following components:
 - the ESD protection circuitry
 - the side connector interface circuitry, and
 - the Option board.

4.1.6.1 Controller and Memory Section

Three main ICs are in the controller and memory section of the main board schematic: the Patriot IC (U800), the static RAM (SRAM) (U804), and the Flash memory (U803).

4.1.6.1.1 Patriot IC (U800)

The Patriot IC (U800) is a dual-core processor containing both a 32-bit microcontroller unit (MCU) and a 16-bit digital signal processor (DSP) in one IC package. It comes in a 256 pin, ball grid array (BGA) package with 1mm pitch solder balls. The Patriot is supplied with two voltages: 1.875 volts (E801) and 2.9 volts (E800). The 1.875-volt supply is used as the core voltage as well as the interface to the memory devices and display. Most of the pins on the Patriot operate from the 2.9-volt supply.

There are two main clocks that are provided to the Patriot:

1. The CKIH pin is provided a 16.8MHz sine wave; this is the most important clock since it is internally used to generate the clocks for both the MCU and DSP cores, as well as most of the peripherals.
2. A 2.9-volt peak-to-peak 32.768kHz square wave is supplied to the MCU and DSP cores. It is generated by an external 32.768kHz crystal (Y701), and a clock buffer circuit that includes U712, U713, U714, C742, C743, C791, C743, C792, R745, R747, R748, R799, R741 and R742. This signal is supplied to the CKIL pin on the dual-core processor. While not as widely used as the 16.8MHz clock, the 32.768kHz clock is needed by some components in the dual-core processor, including the reset circuitry.

4.1.6.1.1.1 Microcontroller Unit (MCU)

The MCU portion of the Patriot has 22.5Kx32 bits of internal RAM and 1Kx32 bits of internal ROM. The internal ROM is used for the bootstrapping code. The MCU has several peripherals, including the following:

- an External Interface Module (EIM)
- the Multiple Queue Serial Peripheral Interface (MQSPI)
- two Universal Asynchronous Receiver/Transmitter (UART) modules, and
- the One-Wire Interface module.

The MCU communicates internally to the DSP through the MCU/DSP Interface (MDI).

External Interface Module (EIM)

The External Interface Module (EIM) is the MCU's interface to the SRAM (U804), Flash Memory (U803), and the display. The EIM lines include the following:

- 24 external address lines
- 16 external bi-directional data lines
- 6 chip selects lines
- read/write line, and
- output enable line, among others.

All of the EIM lines operate at 1.8-volt logic levels; the EIM operates at the MCU clock speed.

Multiple Queue Serial Peripheral Interface (MQSPI)

The Multiple Queue Serial Peripheral Interface (MQSPI) is the MCU's programming interface to other ICs. The Patriot has two independent SPI busses, and each has its own clock line, data-out line (MOSI), and data-in line (MISO). There are 10 SPI chip selects (SPICS) that are programmable to either SPI A, the RF board's SPI bus, or to SPI B, the dedicated VOCON SPI bus. The devices on the SPI A bus include the following:

- the PCIC and FRACN IC on the SPICS4, and
- the ABACUS III on SPICS5.

There is one SPI B chip select used for the MAKO IC U701 on SPICS2 (TP_MAKO_CE). All of the lines of the SPI module operate at the GPIO voltage logic level (see section 4.1.6.1.1.).

There are several devices on the RF board that only have one bi-directional SPI data line. Components U801, U802, and Q801 are configured by the MCU GPIO pin TOUT13 (MISOA_SEL) to route the data line to the appropriate pin on the Patriot depending on which SPI device is being accessed.

Universal Asynchronous Receiver/Transmitter (UART)

The Patriot has two Universal Asynchronous Receiver/Transmitter (UART) modules. UART1 (primary UART) handles the RS 232 lines while UART 2 is not used. The primary UART has the following lines:

- a receive data line URXD
- a transmit data line UTXD, and
- hardware flow control signals RTS (request to send) and CTS (clear to send).

All UART lines are operating at the GPIO voltage logic level (see section 4.1.6.1.1.).

One-Wire Interface

The MCU has a One-Wire Interface module that is used to communicate to a One-Wire device like a USB cable or a smart battery using the Dallas Semiconductor protocol. This module has one external pin, OWIRE_DAT (U800 pin F6), and it uses the GPIO voltage logic level.

4.1.6.1.1.2 Digital Signal Processor (DSP)

The DSP portion of the Patriot has 84Kx24 bits of program RAM and 62Kx16 bits of data RAM. The DSP has its own set of peripherals including the following:

- the Baseband Interface Port (BBP)
- the DSP Timer module, and
- the Serial Audio Codec Port (SAP).

Additionally, the DSP shares some peripherals with the MCU, including the USB interface and the General Purpose Input/Output module (GPIO).

Baseband Interface Port (BBP)

The Baseband Interface Port (BBP) module is the DSP's serial synchronous interface (SSI) to the RF board. The BBP has independent sections for the receiver and the transmitter. The receiver BBP pins include

- the receive data pin SRDB
- the receive clock signal pin SC0B, and
- the receive frame synchronization (sync) signal pin SC1B.

The transmitter's BBP pins include

- the transmit data pin STDB (R816)
- the transmit clock signal pin SCKB (TCLK test point), and
- the transmit frame sync signal pin SC2B (TSYNC).

All BBP lines use the GPIO voltage level (see section 4.1.6.1.1.).

DSP Timer Module

While the BBP receive clock and frame sync signals are supplied by the ABACUS III from the RF board, the BBP transmit clock and frame sync signals are generated by the MAKO IC using the 16.8MHz clock (connected to the TCXO_IN M1 pin). The BBP transmit clock and frame sync signals, along with the BBP transmit data signal, are connected to the Digital-to-Analog Converter (DAC) on the RF board.

Serial Audio Codec Port (SAP)

The Serial Audio Codec Port (SAP) module is the DSP's serial synchronous interface (SSI) to the audio codec on the MAKO IC. The SAP interface consist of four signals:

- the SAP clock line pin SCKA (CODEC_DCLK, R772)
- the SAP frame sync line pin SC2A (CODEC_FSYNC, R773)
- the SAP receive data line pin SRDA (CODEC_TX, R774), and
- the transmit data line pin STDA (CODEC_RX, R775).

The SAP clock is generated by the MAKO IC, U701, and it is a 512kHz, 2.9-volt peak-to-peak wave. The SAP frame sync signal is also generated by the MAKO IC, U701 and it is an 8 kHz, 2.9-volt peak-to-peak square wave.

Universal Serial Bus (USB)

The Patriot's USB peripheral, shared by the MCU and the DSP, provides the required buffering and protocol to communicate on the Universal Serial Bus. The Patriot supports USB slave functionality.

- For receive data: the receive data is routed from the MAKO IC (U701) integrated USB transceiver. Single ended positive data is generated at U701 pin B9 and is sent to the dual-core processor pin URXD_RTS. USB data minus comes from U701 pin C9 and is sent to URXD1 of the dual-core processor.
- For transmit data: the USB data comes out of the Patriot UTXD1 pin and goes to the MAKO IC pin C8.

General Purpose Input/Output Module (GPIO)

The GPIO (General Purpose Input/Output) Module is shared by the MCU and the DSP. This module consists of four 16-pin bi-directional ports and a 15 pin bi-directional port. While some of these pins on these ports are being used for other functions (UART, SPI, SAP, BBP, and Interrupt pins), the remaining pins on those ports may be programmed to become GPIOs that may be used by either the DSP or the MCU. Each GPIO pin has up to 8 alternate output functions and up to 4 alternate input functions. This allows for the GPIO pins to be routed internally to pertinent Patriot modules. Additionally, the GPIO module adds selectable edge-triggered or level-sensitive interrupt functionality to the GPIO pins. An example of GPIO pins include the following:

- the LED control signals (RED_LED and GREEN_LED).

4.1.6.1.2 SRAM (U804)

The static RAM (SRAM) is an asynchronous, 1 MB CMOS device that is capable of 70 ns access speed. It is supplied with 1.8 volts. The SRAM has 19 address lines and 16 data lines connected to the External Interface Module (EIM) of the Patriot IC through the ADDR(23:0) and DATA(15:0) busses.

The SRAM has an active low chip-select EN_CE that is connected to the EIM CS2_N pin. When the SRAM EN_CE pin is not asserted, the SRAM is in standby mode, which reduces current consumption.

Two other control signals from the EIM that change the mode of the SRAM are the read/write signal (R/W), and the output enable signal (OE). The R/W of the EIM is connected to the SRAM EN_WE pin while the OE signal from the EIM is connected to the SRAM EN_OE pin. The SRAM is in read mode when the EN_WE pin is not asserted and the EN_OE pin is asserted. The SRAM is in write mode when the EN_WE pin is asserted, regardless of the state of the EN_OE pin.

The other SRAM pins are the lower byte enable pin EN_BLE and the upper byte enable pin EN_BHE. These pins are used to determine which byte (EN_BLE controls data lines 0-7 and EN_BHE controls data lines 8-15) is being used when there is a read or a write request from the Patriot. The EN_BLE pin is controlled by the EIM EB1_N signal while the EN_BHE pin is controlled by the EB0_N signal.

4.1.6.1.3 Flash Memory (U803)

The Flash memory IC is a 8-megabyte CMOS device with simultaneous read/write or simultaneous read/erase operation capabilities with 70 ns access speed. It is supplied with 1.8 volts. The Flash memory has its 22 address lines and 16 data lines connected to the EIM of the Patriot IC through the ADDR(23:0) and DATA(15:0) busses. The Flash memory contains host firmware, DSP firmware, codeplug data, and tuning values.

The RESET_OUT of the Patriot IC (U800) is at the GPIO voltage logic level (see section 4.1.6.1.1.). Components CR800 and R812 are used to convert the voltage down to a 1.8-volt logic level, and this 1.8 volt reset signal is fed to the Flash RESET pin. When this pin is asserted (active low logic), the Flash is in reset mode. In this mode, the internal circuitry powers down and the outputs become high impedance connections.

The Flash active low chip select pin, EN_CE, is connected to the active low CS0 pin (TP_CS0 test point) of the EIM. When the EN_CE is not asserted, the Flash is in standby mode which reduces the current consumption.

Several other active low controls pins determine what mode the Flash memory is in:

- the address valid pin ADV which is connected to the EIM LBA signal
- the output enable pin EN_OE that is connected to the EIM OE signal, and
- the write enable pin EN_WE which connected to the EIM EB1 signal.

For read mode, the ADV and EN_OE pins would be asserted while the EN_WE pin would not be asserted. When the EN_WE is asserted and the EN_OE pin is non-asserted, the Flash would operate in the write mode.

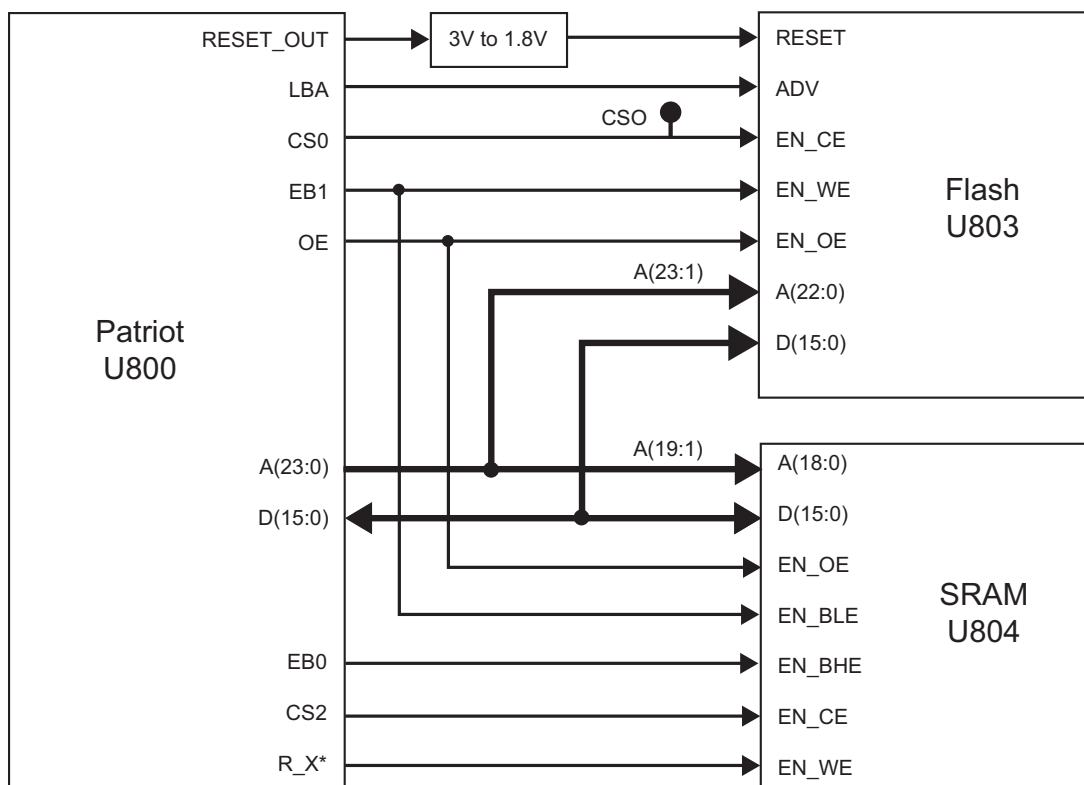

Figure 4.1-1. Controller Memory Interface

4.1.6.2 Audio and Power Section

Two main ICs reside in the audio and power section of the schematic diagram:

- the MAKO IC (U701)
- the VSW1 Driver IC (Q702)

4.1.6.2.1 MAKO IC (U701)

The MAKO IC is a mixed-signal IC that provides control, clock generation, digital support, audio, and voltage regulation functionality. It comes in a 176-pin, ball-grid array (BGA) package with 0.8mm pitch solder balls. The MAKO IC is supplied with switched battery voltage SW_B+.

4.1.6.2.1.1 Voltage Regulation

The MAKO IC contains all of the regulators that are used in the design of the VOCON board:

VSW1, VSW2, V_2.9, V1.55, V1.875, and VCC5. VSW1 is a programmable switching regulator controlled by the MAKO IC on pin SW1_SUMCOMP_DL, while the current is sourced by a driver Q300 using the switched battery voltage (SW_B+). The switching frequency of VSW1 (R711) is programmable by the dual-core processor through the SPI bus. The VSW1 voltage is supplied to the input pin of MAKO's VSW2 regulator (pin SW2_VCCS).

The VSW2 regulator is a SPI programmable switching regulator. The initial and programmed output of VSW2 (C715) is 2.3 volts. The VSW2 voltage is used internal to the MAKO IC to supply the 1.875 volt (V1.875) and 1.55 volt (V1.55) linear voltage regulators. The V1.875 voltage (L703) is supplied to the dual-core processor U800 (EIM voltage), SRAM U804, and Flash memory U803. The V1.55 voltage (R718) is supplied to the dual-core processor U800 (core voltage).

The V_2.9 volt regulator is a linear regulator within the MAKO IC that used VSW1 as its input. The initial output of V_2.9 (L704) is 2.775 volts, which is then programmed to 2.9 volts by the dual-core processor via the SPI bus. The V_2.9 voltage is supplied to the dual-core processor (I/O ring - SPI, BBP, SAP, UART, GPIO, etc.), the display module connector J601, and the many discrete components that interface with the dual-core processor and the MAKO IC.

4.1.6.2.1.2 Microcontroller Unit (MCU) Interface

The MAKO IC has a four-wire, SPI connection to the dual-core processor (SPI B). The SPI B clock is connected to the SPI_CLK pin E6. The SPI B MOSI line is connected to the SPI_DI pin B6. The SPI B MISO line is connected to the SPI_DO pin C6. The MAKO SPI B chip-select signal is connected to the SPI_CS pin D6. Through this interface, the dual-core processor can program the voltage regulators, the CODEC, the transmit and receive audio filters and amplifiers, digital support multiplexing, and read information from the ADC.

The MAKO IC has a 10-bit ADC with eight general-purpose channels and two voltage-monitoring channels. Five out of the eight general-purpose channels are assigned to the display backlight button on the control head (ATOD_2), the monitor volume (ATOD_1), the two-position toggle switch (ATOD_3), the OPT_SEL_IN (ATOD_8), and board type ID (ATOD_5). The other three general purpose channels are unused. Battery voltage is also monitored by the ADC. The dual-core processor reads the ADC values through the SPI bus.

4.1.6.2.1.3 Audio Circuitry

A16-bit CODEC is integrated into the MAKO IC and programmable by the dual-core processor through the SPI bus. The CODEC converts microphone audio data into a digital bit stream for processor by the DSP and converts receive audio data that was processed by the DSP into an analog audio signal for amplification to a speaker. The CODEC interfaces to the DSP through the 4-wire SAP bus. The CODEC clock, which is 512kHz, is generated by the MAKO IC and supplied on the VC_DCLK pin (R772). The CODEC 8 kHz frame synchronization signal is generated by the MAKO IC and supplied on the VC_FSYNC pin (R773). The CODEC transmit data signal is on the VC_TX3V pin and the CODEC receive data signal is on the VC_RX pin. For the MAKO IC to generate the clock and frame sync signals, a 24.576 MHz crystal Y702 is supplied to the XOUT and XIN pins.

The MAKO IC contains internal amplification (digital and analog), filtering, and multiplexing functionality for both receive and transmit audio. These functions are programmable by the dual core processor through the SPI bus. The input for the internal microphone audio (C755) is the INT_MIC_P pin, while the input for the external microphone audio (C754) is the EXT_MIC_P pin. The differential output for the internal speaker is the INT_SPKR_P pin and INT_SPKR_M pin. The differential output for the external speaker is the EXT_SPKR_P pin (C769) and EXT_SPKR_M pin (C768).

4.1.6.2.2 Regulator

The 5 V regulator is internal to the MAKO IC and uses SW_B+ as its input voltage at pin V08_I (C720). The 5 V supply (L705) is used by the bi-directional voltage translators integrated into the MAKO IC, the MAKO IC protection diodes, and the ESD protection circuitry.

The 1.55 V regulator (programmable through the SPI bus) is integrated into the MAKO IC. This regulator uses VSW2 to source the current. The 1.55 V supply (R718) is used by the dual-core processor U701 for its core voltage and clock amplifier.

4.1.6.2.3 Audio Pre-Amplifier

The audio pre-amplifier is integrated into the MAKO IC. The pre-amplifier's supply voltage and gain are programmable and controlled by the dual-core processor through the SPI bus. The input to the pre-amplifier is routed from the internal gain stages within the MAKO IC. The differential output of the pre-amplifier is the VC_OUT_P pin (R844) and VC_OUT_M pin (R798).

4.1.6.2.4 Audio Power Amplifier

The audio power amplifier, supplied by SW_B+, is integrated into the MAKO IC U701. The audio PA is a programmable BTL type and is controlled by the dual-core processor through the SPI bus. The operational state of the PA, as well as selecting between the internal and external audio path, is controlled by the dual-core processor via the SPI bus.

The differential input to the audio PA comes from a low-pass filter (R844, R798, C764, C765, and C790) at the output of the audio pre-amplifier.

4.1.6.3 Interface Support Section

The interface support section includes the following:

- the MAKO IC (U701)
- the ESD protection circuitry, and
- the universal connector interface circuitry.

4.1.6.3.1 MAKO IC U701

The digital-support functions are performed by the MAKO IC. The MAKO IC is contained in a 176-pin BGA with 0.8mm pitch solder balls. The MAKO IC is supplied with three clocks. It is supplied with a 16.8 MHz clock from the transceiver board. It uses a 32.768 kHz crystal to boot up the dual core processor and for the real-time clock. It also uses a 24.576 MHz crystal to generate the SAP clock and frame synchronization signals.

The MAKO IC includes that one-wire option detect support, watchdog timer, and the radio's universal (accessory) side connector interface. It also monitors the position of the on/off switch in order to control the power-up/power-down sequence.

4.1.6.3.1.1 Side Connector Interface, Logic Level Translation, and Boot Data Path Control

The LH Data bidirectional translation is performed internal to the MAKO IC and 3V logic level is on MAKO pin SB96D_BDO_KF_3V.

4.1.6.3.1.2 USB Transceiver

The USB transceiver is internal to MAKO IC U701, and is capable of transmitting and receiving serial data at a rate of 12 megabits per second. The differential USB data comes from the side connector, through the 33-ohm resistors R837 and R838 and then to the USB1_DP and USB1_DM pins on U701. The data will then go through some interfacing and multiplexing internal to the transceiver for 6-wire USB operation and onto the output pins. The USB receive interface through the transceiver to the dual core processor is as follows: DP routed to USB_VPI, DM routed to URXD1_USB_VMI, and the differentially decoded data is output on URTS1_XRXD pin.

The USB transmitter is enabled when the RS232_USB* and USB_TXENAB signals are both driven low by the dual-core processor. The single-ended data is output from the dual-core processor on the UTXD1_USB_VPO pin and goes to USB1_DAT_TXD on U701. The data is driven out differentially on the USB1_DP and USB1_DM pins, which go to the side connector. The dual-core processor sends the single-ended zero signal from pin USB_VMO to the USB1_SE0 pin on U701.

When a USB cable is attached, pin CTS_CABLE_DET_5V is driven low and goes through level translation in U701 and the output of CTS_CABLE_DET_3V is pulsed low and sent to the dual-core processor. This line controls the USB and RS232 modes so that the data that is on those lines are routed to the USB transceiver when a cable is detected. If a USB cable is not detected, CTS_CABLE_DET_3V is high, the transceiver is put in suspend mode and the DP and DM pins can now handle 5V tolerance for RS232 mode.

4.1.6.3.1.3 One-Wire Support

New options and accessories that attach to the side connector are identified by the dual-core processor using the One-Wire protocol. The One-Wire pin on the side connector serves as the One-Wire data pin. This signal is connected to the ONE_WIRE_OPT pin. This pin is connected to the dual-core processor One-wire bus ONE_WIRE_UP through the MAKO IC, U701, internal isolation switch controlled by the SPI commands sent from the dual-core processor. This isolation is needed to prevent possible contention on the One-Wire bus when a smart battery is attached to the radio.

These new accessories are to ground, designator R666, of the side connector. When this occurs, the ONE_WIRE_OPT is asserted and the dual-core processor detects the change. The dual-core processor then sends a command through the SPI lines to the U701 MAKO IC to connect the side connector One-Wire line to the dual-core processor One-Wire bus. In the case of the USB cable, the dual-core processor reads the One-Wire data from the cable and, upon determining that a USB cable is attached, programs the digital-support IC for USB mode.

4.1.6.3.1.4 Watchdog Timer

The watchdog timer is a 125ms counter that is integrated into the MAKO IC U701 and used during the power down sequence. The MAKO IC will begin the power down sequence when a low-to-high transition occurs on MECH_SW pin (MAKO pin E4). Once this transition occurs, the MAKO IC begins the watchdog timer. Upon expiration, RESETX (MAKO pin C5) is asserted and all of the MAKO regulators are shutdown. The dual-core processor can refresh the watchdog timer so that the software has enough time to complete its tasks before the power is taken away.

4.1.6.3.1.5 32 kHz Oscillator and CMOS Output

There is an internal 32kHz oscillator circuitry to the MAKO IC U301 that is based off of a 32.768 kHz crystal Y701 and additional load capacitors C701 and C702. The output of the 32 kHz oscillator is a logic_vdd voltage (approximately 2.9 volts peak-to-peak), 32kHz +/- 20% square wave on pin GATED_32K_CLK. This 32 kHz signal is routed through an analog switch U302 and sent to the dual-core processor CKIL pin. This signal is only used to boot up the dual-core processor.

After the dual-core processor boots up, the select input (R799) of the analog switch is asserted high allowing for the processor to receive an accurate 32.768 kHz, 2.9 V peak-to-peak square wave. This signal is generated by tapping the output of the 32.768 crystal and buffering the signal with the following components: U713, R745, R746, C743, C792, R742, and R741. The 32.768 kHz clock signal allows for the completion of real-time applications.

4.1.6.3.2 ESD Protection Circuitry

Several components on the VOCON section were added to protect the circuitry from Electrostatic Discharge (ESD). The side connector signal lines are exposed and require ESD protection components. These protection components include:

- 5.6 volt zeners (VR659 and VR662) on the CTS and RTS lines, microphone lines, and the option select lines
- 12 volt zener (VR650) on the internal and external speaker audio lines
- 13 volt zener (VR658) on the OPTB+ line, and
- low capacitance ESD suppressors (VR678, VR651, and VR652) on the USB data lines.

4.1.6.3.3 Universal Connector (Side Connector) Interface Circuitry

An important circuit in the side connector interface is the Option Select 2 line comparator. The op-amp (U601) is used as a comparator for the option select 2 line. The voltage divider network of R658 and R673 determines the comparator threshold. The remaining components on the side connector interface consist of current-limiting serial resistors and noise-suppressing shunt capacitors.

4.1.6.3.3.1 Universal Connector (Side Connector) and Option Selects

The universal connector is located on the side of the radio. It is the external port or interface to the outside, and is used for programming and interfacing to external accessories. The universal connector is connected to the main board via a flex circuit at connector J650.

Most of the signals are extensions of circuits described in other areas of this manual. However, there are two option select pins used to configure special modes: Option Select 1 and Option Select 2. These pins are controlled by accessories connected to the universal connector. Connections to the universal connector and J650 are shown in Figure 4.1-2. and Figure 4.1-3., respectively.

Table 4.1-1 outlines their functions as defined at the universal connector.

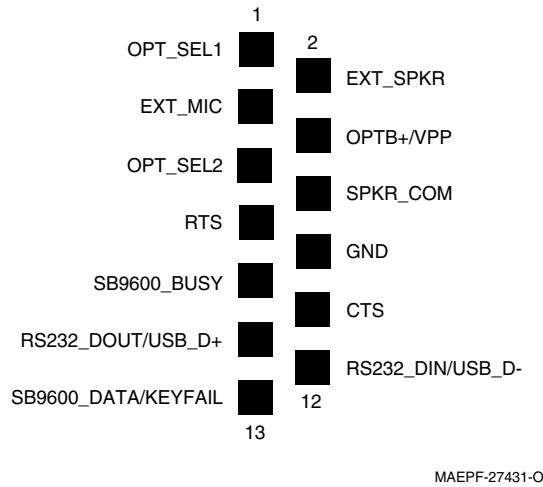

Figure 4.1-2. Universal (Side) Connector

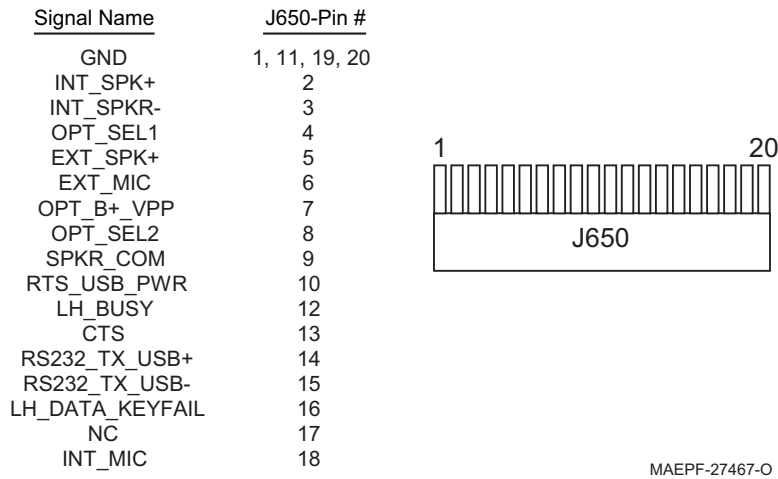

Figure 4.1-3. VOCON Connector J650

Table 4.1-1. Option Select Functions

FUNCTION	Option Select 1	Option Select 2
External PTT	0	0
No Function (Normal)	1	1
Man Down	1	0
External Speaker	0	1

4.1.6.3.4 The Option Board

The Option Board consists of the "keypad module" and the "display module" for models II and III of the XTS 2500/XTS 2500I radio.

4.1.6.3.4.1 Display Module

An optional integral 96 pixels by 64 pixels LCD display module is available with either a 3 x 2 keypad with a navigational button (Model II radios), or 3 x 6 keypad with a navigational button (Model III radios). This unit is not considered field-repairable. The display module is connected to the VOCON section through the flex connector (J900).

The display is controlled by the Patriot's MCU core. The MCU core programs the display through the following:

- EIM data lines D0 - D7 (pins 9 through 16, respectively),
- the display chip select line (pin 5),
- the EIM "write only" line (pin 8), and
- the EIM address 0 line (pin 7).

The EIM address 0 is used to select the register to be programmed. The Patriot may reset the display module through pin 6. The display is supplied with 1.8 volts (C901) to pin 17 and 3 volts (C902) to pin 18.

The Patriot GPIO BL_EN controls the display backlighting; that signal goes to pin 43 of the J601 connector (on the radio board), and the corresponding pin 3 of the J901 connector (on the Option board).

Pin 4 of the J601 connector (on the radio board), and the corresponding pin 42 on the J901 connector (on the Option board) is supplied with 7.5 volts. The 7.5 volts is used to power the LEDs on the display module.

Pin 2 of the J601 connector (on the radio board), and the corresponding pin 44 on the J901 connector (on the Option board), is supplied with the V2 regulated voltage. The V2 regulated voltage is used to power DISPLAY_VCC.

Pin 1 of the J601 connector (on the radio board), and the corresponding pin 45 on the J901 connector (on the Option board), is supplied with 1.8 volts. The 1.8 volts is used to power DISPLAY_VDD.

4.1.6.3.4.2 Keypad Module

The keypad module is connected to the main board through flex connector (J601) on the radio board schematic and J901 on the Option board schematic. The keypad is read through a row-and-column matrix made up of ROW0, ROW1, ROW2, ROW3, ROW4, ROW5, ROW6 and COL0, COL1, and COL2. This totals 18 keys on the keypad. When a key is pressed, a row and a column are connected to one another.

The Patriot determines a key press by a scanning algorithm. Each column line is configured as an open drain output and pulled low. The Patriot then scans the row pins (each row pin has an internal pull up resistor). If a row signal is read low, then the Patriot determines that a key was pressed. If none of the row signal lines are low, then another column line is pulled low and the row scanning routine occurs.

The Patriot GPIO BL_EN controls the keypad backlighting; that signal goes to pin 43 of the J601 connector (on the radio board), and the corresponding pin 3 of the J901 connector (on the Option board). Pin 42 is supplied with 7.5 volts, which is used to power the LEDs on the keypad module.

4.1.6.3.5 Encryption Module

The encryption module (secure models only) connects directly to the VOCON board and interfaces directly with the vocoder digital circuitry. It contains one custom microcontroller IC (Armour) to perform digital, numerical, encryption algorithms.

The encryption modules are designed to digitally encrypt and decrypt voice for ASTRO and NON-ASTRO in XTS 2500/XTS 2500I. This section covers the encryption modules, hardware kits **0104020J49 (Model 1.5), 0104020J50 (Model 2) and 0104020J51 (Model 3)**.

NOTE: The encryption modules are NOT serviceable. The information contained in this section is only intended to help determine whether a problem is due to an encryption module or the radio itself.

The encryption module uses a custom encryption IC and an encryption key variable to perform its encode/decode function. The encryption key variable is loaded into the encryption module, via the radio's universal (side) connector, from a hand-held, key variable loader (KVL). The encryption IC corresponds to the particular encryption algorithm purchased. [Table 4.1-2](#) lists the encryption algorithms and their corresponding kit numbers.

The encryption module operates from two power supplies (UNSW_B+ and SW_B+). The SW_B+ is turned on and off by the radio's On/Off switch. The UNSW_B+ provides power to the encryption module as long as the radio battery is in place.

Key variables are loaded into the encryption module through connector J601, pin 34. Depending on the type of encryption module, up to 16 keys can be stored in the module at a time. The key can be infinite key retention or 30-seconds key retention, depending on how the codeplug is set up.

The radio's host processor communicates with the encryption module on the Synchronous Serial Interface (SSI) bus. The SSI bus consists of four signal lines. A communications failure between the host processor and the secure module will be *ERROR 09/10* or *S03 error* message on the display.

To troubleshoot the encryption module, refer to the flowcharts in [Chapter 6.1 "VHF Troubleshooting Charts."](#)

Table 4.1-2. Encryption Module Software Kits and Algorithms

Software Kit Number	Algorithm
Q667AB (7/800), Q667AE (V,U1,U2)	ADP SFWR DSP BASED CRYPTO
Q159AC	XTS 2500/XTS 2500I UCM HARDWARE ENCRYPTION
Q629AD	AES ENCRYPTION
Q625AU	DES, DES-XL, DES-OFB ENCRYPTION
Q668AC	ADP UCM ENCRYPTION W/DES, DES-XL, DES-OFB
H869BQ	MULTI KEY
Q406AC	ADP UCM ENCRYPTION
QA00204AA	MULTIKEY AND ADP
	ADP UCM ENCRYPTION W/AES

4.1.6.3.6 System Clocks

The Patriot is supplied with two clocks:

1. The first clock, a 16.8 MHz sine wave, comes from the RF portion of the radio. It is conditioned by the clock buffer circuit, which includes Q709, R722, R740, R743, R729, R797, C726, C725 and C727.
2. The other clock supplied to Patriot is a 32.768 kHz square wave. This clock is generated by the external 32.768kHz crystal Y701, and a clock buffer circuit that includes U713, R745, R746, C743, C792, R742 and R741. This signal is supplied to the CKIL pin on the dual-core processor.

4.1.6.4 Transmit Audio Path

Refer to [Figure 4.1-4](#). The single-ended internal microphone audio enters the VOCON board through 20 pin side connector (J650), and the internal microphone bias is set by circuitry that includes R751, R753, C751, C753 and C755. The internal microphone signal is connected to the INT_MIC_P pin, which is the input terminal on the MAKO IC internal op-amp G1 after the signal is multiplexed. The gain of the G1 pre-amp is set to +15 dB, which is programmed by dual-core processor SPI lines.

The external microphone audio enters the VOCON board through the remote connector J102, pin10, and the external microphone bias is set by circuitry that includes R750, R752, C750, C752 and C754. The external microphone signal is connected to the EXT_MIC_P pin, which is an input terminal on the MAKO IC internal op-amp G1 after the signal is multiplexed. The gain of the G1 pre-amp is set to +15 dB, which is programmed by dual-core processor SPI lines.

The dual-core processor, through the SPI bus, programs a multiplexer internal to the MAKO IC to select one of the microphone signals. Then, the selected microphone signal goes through the G1 pre-amplifier stage and on to a programmable gain amplifier (G2) before it goes to the CODEC for A/D conversion. The resulting digital data is filtered and sent to the DSP on the CODEC_TX line from the MAKO IC VC_TX3V pin. After additional filtering and processing, the DSP sends the data-out from the STDB pin, labeled TX_SSI_DATA to the RF interface connector.

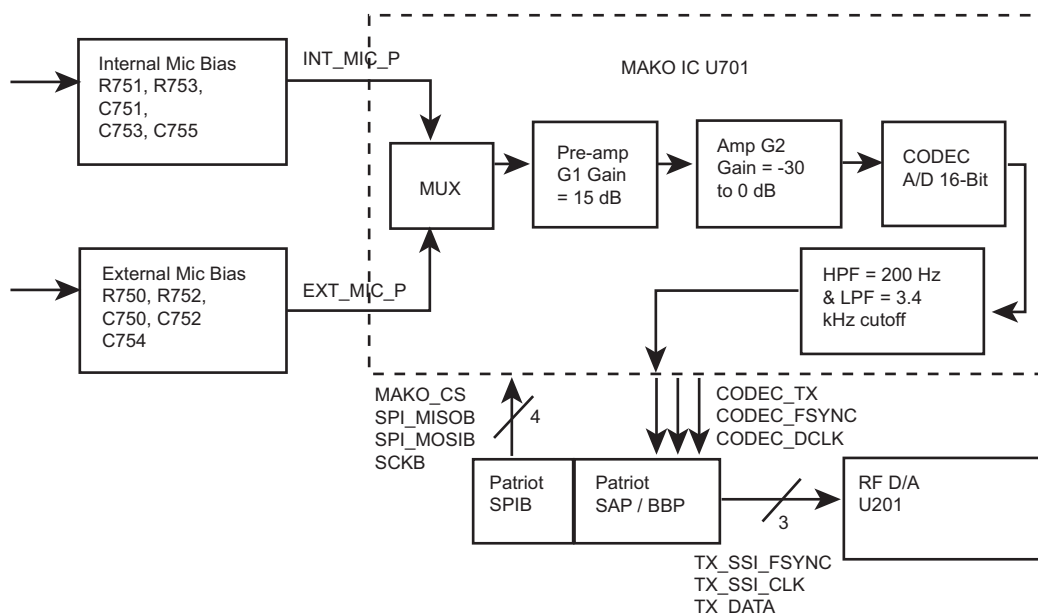

Figure 4.1-4. VOCON Transmit Audio Path

4.1.6.5 Receive Audio Path

Refer to [Figure 4.1-5](#). The receive audio data comes from the Abacus III IC U401 (DOUTA) to the dual-core processor SRDB pin. The DSP decodes the data and sends it out through the CODEC_RX line to the MAKO IC VC_RX3V pin. The CODEC filters, adds digital programmable gain G1, then converts the digital data into an analog audio signal, which in turn is sent to programmable attenuator G3. The signal is then sent through an internal programmable differential preamplifier (G4) to add gain and outputs the signal on pins VC_OUT_P and VC_OUT_M of the MAKO IC.

This output from the preamp is then filtered through circuitry R798, R844, C764, C765, C790, and then sent back to 2 independent internal BTL differential power amplifiers, G5 & G6, of the MAKO IC. The power amplifiers are programmed to a fixed gain of 26 dB through the dual-core processor SPI lines and PA control registers.

The dual-core processor selects whether the amplified audio is routed to the internal speaker or the external speaker through the SPI lines based upon which amplifier is turned on as shown in the PA control block. The output audio is routed on MAKO IC pins INT_SPKR_P and INT_SPKR_M for internal and EXT_SPKR_P and EXT_SPKR_M for external speaker lines.

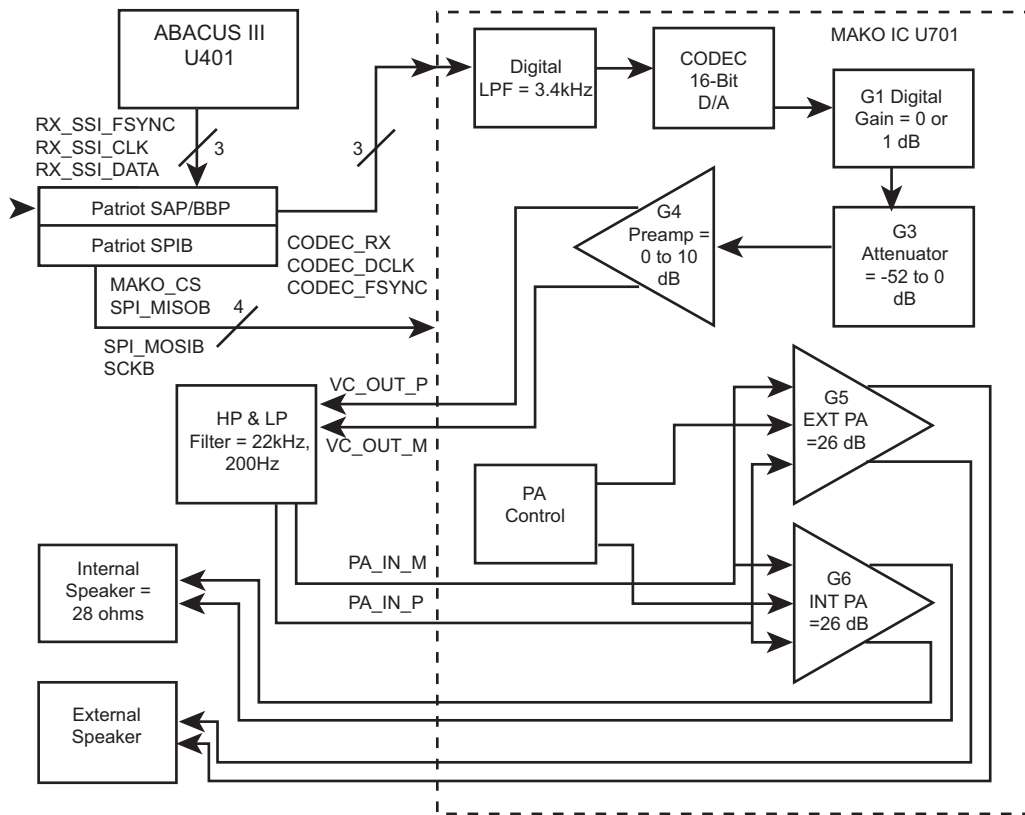

Figure 4.1-5. VOCON Receive Audio Path

Chapter 4.2 UHF1 Detailed Theories of Operation

4.2.1 Introduction

This chapter provides a detailed circuit description of the ASTRO XTS 2500/XTS 2500I/XTS 2250/XTS 1500 radio board. When reading the theory of operation, refer to the appropriate schematic and component location diagrams located in the back of this manual. This detailed theory of operation can help isolate the problem to a particular component.

This manual is to be used in conjunction with the ASTRO XTS 2500, XTS 2500I, XTS 2250, XTS 1500, MT 1500 Digital Portable Radios Basic Service Manual (Motorola part number 6816984H01), which uses the pass/fail service approach to radio problems.

4.2.2 Frequency Synthesis

The complete synthesizer subsystem consists of the following:

- The **reference oscillator** (Y200)
- Two **voltage-controlled oscillators** (TX and RX)
- Two **voltage-controlled oscillator discreet buffers** (TX and RX)
- The **synthesizer** (U202)

The **reference oscillator** contains a temperature-compensated 16.8 MHz crystal. This oscillator is digitally tuned and contains a temperature-referenced, six-bit, analog-to-digital (A/D) converter. The output of the oscillator (pin 3 on Y200) is applied to pin 23 (XTAL1) of U202 through capacitor C214.

The **voltage-controlled oscillators** are varactor-tuned. The voltage (2V - 11V) varies as it is being applied to varactors D251 to D254 and D271 to D274 of their respective Voltage-Controlled Oscillator (VCO). The capacitance of the varactors also varies, thereby changing the output frequency of the VCOs. Both the VCOs are used to cover the entire 90MHz bandwidth of the UHF range 1, 380MHz to 470MHz band.

- TX VCO covers the transmit frequencies from 380 MHz to 470 MHz
- RX VCO covers the receive frequencies from 306.65 MHz to 396.65 MHz

The **TX VCO** and the **RX VCO** are selected using AUX 3 and AUX 2 respectively. Both VCOs are connected to the same Prescaler filter (C289, L277 and C290) feeding back to PREIN of the U202, through C291.

The **synthesizer** IC consists of the following:

- A prescaler
 - A programmable loop divider
 - A divider logic control
 - A phase detector
 - A charge pump
 - An A/D converter for low-frequency digital modulation
 - A balance attenuator to balance the high-frequency analog modulation to the low-frequency digital modulation
 - A 13V positive voltage multiplier
 - A serial interface for control
-

- A filter for the regulated 5 and 3 volts

The 13V, being generated by the positive voltage multiplier circuitry, should be present at pin 47 of U202. The serial interface (SRL) is connected to the microprocessor via the data line (pin 7 of U202), the clock line (pin 8 of U202), and the chip-enable line (pin 9 of U202).

The complete synthesizer subsystem works as follows:

1. The buffered output of the VCO will be present at R267 in receive mode and R289 during transmit mode.
2. The output of the Prescaler filter is present at C291 and applied to pin 32 of U202. The prescaler in U202 is a dual-modulus type with selectable divider ratios. This divider ratio is controlled by the loop divider, which in turn receives its input from the SRL. The loop divider adds or subtracts phase to the prescaler divider by changing the divider ratio via the modulus control line.
3. The output of the prescaler is then applied to the loop divider.
4. The output of the loop divider then feeds the phase detector. The phase detector will compare the loop divider's output signal from the VCOs. The VCO signal is divided down after it is applied to pin 32 of U202. The result of the comparison is a pulsed DC signal which is applied to the charge pump.
5. The charge pump outputs a current that will be present at pin 43 of U202. The loop filter consisting of R202, C202, R203, C203, R201, C201, C236, C237, C238, C239 and C240, will convert this current into a voltage that will be applied to varactors D251, D252, D253, D254, D271, D272, D273 and D274, to alter the output frequency of the VCO.

In order to modulate the PLL, the following two-port modulation method is utilized: The analog modulating signal is applied to the (1) A/D converter as well as to the (2) balance attenuator:

1. The A/D converter converts the low-frequency analog modulating signal into a digital code. When the digital code is applied to the loop divider, it causes the carrier to deviate.
2. The balance attenuator is used to adjust the VCO's deviation sensitivity to high-frequency modulating signals.

4.2.3 Antenna Switch

An electronic PIN diode switch steers RF between the receiver and transmitter. Switching is derived from the interaction of PIN diodes D170 and D171 as well as the quarter-wavelength components (L176, C178 & C192).

1. In transmit mode:
 - a. RF is routed to the anode of diode D170.
 - b. PIN Diodes D170 and D171 are forward biased by turning on transistor Q197 via RX pin of U102 (pulled low). Due to the characteristics of the quarter-wavelength circuit (L176, C178 and C192), the receiver path appears "disconnected."
2. In receive mode:
 - a. RF signal is routed via C171 through L176 and coupling capacitor C179.
 - b. With Q197 turned OFF, both PIN diodes are not biased and the transmit path through D170 becomes "Open."

4.2.4 Receiver

The receiver consists of the following:

- Front end
- Back end

4.2.4.1 Front End

For the purposes of this discussion, the receiver front end is defined as being the circuitry from the antenna switch to the output of the IF crystal filter. The receiver front end converts the incoming RF signal into Intermediate Frequency (IF) of 73.35MHz while providing spurious rejection and channel selectivity. A review of the interstage components of the front end follows, with emphasis on troubleshooting considerations.

The received RF signal is passed through quarter wavelength components L176, C178 and C192, (which are anti-resonant at the radio's transmitter frequencies). Both PIN diodes D170 and D171 must not be biased to properly route the received RF signal.

Next is the varactor-tuned preselector filter made up of C2, C9, C61, C62, C63, C64, C65, C83, C84, D3, D10, L5, L12, L61, R13 and R14. The preselector is positioned right after the antenna switch to provide the receiver preamp with some protection against strong signal, out-of-band signals, and first-image suppression.

The stage following the preselector is a step attenuator (U2). This attenuator provides 15 dB step attenuation to protect the receiver from strong RF signals. The attenuator is controlled by a DSP-based algorithm that continuously monitors signal strength. When the ON threshold is exceeded (approximately -95 dBm), the attenuator is activated via a DAC in the PCIC by the host. The attenuator remains activated until the signal drops below the OFF threshold (approximately -115 dBm including the 15 dB attenuation). Hysteresis and timer functions are included in the algorithm to enhance performance. The algorithm controlling the attenuator is enabled via the CPS for each personality. When the algorithm is disabled, the attenuator is essentially a short circuit from input to output.

After the step attenuator, the received signal is applied to the **receiver preamp, Q29**. The preamp is a transistor, which has been biased and matched for optimum intermodulation (IM), noise figure (NF), and gain performance. Components C20, C71 and L63 match the input of the amp to the step attenuator output. The preamp is supplied by a 5V analog regulator and is biased at approximately 0.75Vdc at the base and 2Vdc at the collector.

The output of the amp is matched to a second **two-pole preselector** filter of the type previously discussed. The match is via C35, C41 and L74. The subsequent stage in the receiver chain is the **1st mixer U1**, which uses low-side injection, to convert the RF carrier to an intermediate frequency (IF) of 73.35 MHz. Since low-side injection is used, the LO frequency is offset below the RF carrier by 73.35 MHz, or $f_{LO} = f_{RF} - 73.35 \text{ MHz}$. The mixer utilizes GaAs technology in a double-balanced, Gilbert Cell configuration.

A balun transformer (T51) is used to couple the RF signal into the mixer. The primary winding of T51 is matched to the preceding stage by C51 and L57. The secondary winding of T51 provides a differential output. The center tap pin is grounded via a 75-ohm resistor that sets the mixer bias current. The differential signal is applied to the mixer through pin 4 and 5.

The final stage in the receiver front end is a three-pole crystal filter (FL51). The crystal filter provides some of the receiver's adjacent channel selectivity. The input to the crystal filter is matched to the 1st mixer using components L72, L73, L54, and C57. The output of the crystal filter is matched with components C58 and L55. The crystal filter provides at least 80dB of second image protection and improves IM distortion in the ABACUS III IC.

4.2.4.2 Back End

In the **ABACUS IC (U401)**, the first IF frequency is amplified and then down-converted to the second IF frequency (2.25 MHz). At this point, the analog signal is converted into two digital bit streams by a sigma-delta A/D converter. The bit streams are then digitally filtered, mixed down to baseband, and filtered again. The output data stream is then sent to the Patriot IC, where it is decoded to produce the recovered audio.

The ABACUS IC (U401) is electronically programmable. The amount of filtering, which is dependent on the radio channel spacing and signal type, is controlled by the microcomputer. Additional filtering, which used to be provided externally by a conventional ceramic filter, is replaced by internal digital filters in the ABACUS IC.

The ABACUS IC contains a feedback Automatic Gain Control (AGC) circuit to expand the dynamic range of the sigma-delta converter. The differential output data contains the quadrature (I and Q) information in 16-bit words, the AGC information in a 9-bit word, imbedded word sync information, and fill bits. Two synthesizers are available on the chip for second LO and sampling clock (18 MHz) generation.

The second LO/VCO is a Colpitts oscillator built around transistor Q401. Varactor diode (D402) in the VCO is used to adjust the VCO frequency. The control signal for the varactor is derived from a loop filter consisting of C440, R417, C441, R418, and C480. The sampling clock is derived from a negative resistance generator (on the chip) available at CLKP, CLKN, and an external tank circuit (L403, C423, and D401). The loop filter for the clock is realized by C448, R408, and C425.

4.2.5 Transmitter

The RF power amplifier (PA) consists of

- an RF driver (**U101**) and
- a Silicon N-Channel MOSFET type transistor RF power amplifier (**Q101**).

RF input drive level of approximately +3dBm is supplied from the transmit VCO buffer. This input drive level is applied to pin 16 (RFIN) of **U101**. The dc power is applied to pins 6, 7, and 14 of **U101** and to the drain of **Q101** via a filtered RAW_B+. Power control is achieved by varying the dc bias (and thus the gain) at pin 1 of **U101** and the gate of **Q101**. The amplified RF signal leaves the RF final PA (**Q101**) at the drain and is applied to the discrete directional coupler via an impedance match. The RF signal passes through the coupler, a discrete antenna switch, and a discrete harmonic filter before finally reaching the antenna launch connector.

A portion of the forward RF power is sampled by the directional coupler, applied to the diode (D172) for rectification, and the resulting dc signal is fed back to pin 1 of the Power Control IC (PCIC, U102). This dc signal is representative of the forward RF power being passed through the directional coupler. The dc signal is used by the PCIC to regulate the transmitted RF power level.

The PCIC is the heart of the power control loop. The rectified feedback is internally compared to an internal Digital-to-Analog Converter (DAC) output voltage in the PCIC to determine the amount of DC bias voltage at pin 4. This voltage at pin 4 of the PCIC controls the gain (and thus the output power, as explained above) of the RF driver (**U101**) and the RF power amplifier (**Q101**) via a fixed resistor divider network.

U103 senses the temperature of the printed circuit board (PCB) near the RF Power Amplifier (**Q101**) and provides a dc level representative of this temperature to pin 30 of the PCIC. The PCIC uses this input to cut back the output power level after a certain temperature threshold is reached. This ensures (1) radio integrity while transmitting in extreme ambient conditions hotter than the radio's operating temperature range and (2) acts as a safety feature to prevent any thermal runaway fault conditions.

Pin 32 of the PCIC powers the Temperature Sense IC (U103) and forward biases the antenna switch diodes (D170 and D171) while the radio is in transmit mode. This routes the RF signal from the transmitter to the antenna, as explained above. The antenna switch diodes are not biased during receive and standby modes; therefore, any RF signal present at the antenna is applied to the receiver.

4.2.6 VOCON Functional Blocks

The three main functional blocks of the VOCON section consist of the following sections:

- the Controller and Memory Section, consisting of the following components:
 - the Patriot IC (U800)
 - the dual-core processor with the microcontroller unit (MCU) and a digital signal processor (DSP)
 - the SRAM IC (U804) and FLASH IC (U803) memory devices.
- the Audio and Power Section and digital support are all embedded into the MAKO IC (U701).
- the Interface Support Section, consisting of the following components:
 - the ESD protection circuitry
 - the side connector interface circuitry, and
 - the Option board.

4.2.6.1 Controller and Memory Section

Three main ICs are in the controller and memory section of the main board schematic: the Patriot IC (U800), the static RAM (SRAM) (U804), and the Flash memory (U803).

4.2.6.1.1 Patriot IC (U800)

The Patriot IC (U800) is a dual-core processor containing both a 32-bit microcontroller unit (MCU) and a 16-bit digital signal processor (DSP) in one IC package. It comes in a 256 pin, ball grid array (BGA) package with 1mm pitch solder balls. The Patriot is supplied with two voltages: 1.875 volts (E801) and 2.9 volts (E800). The 1.875-volt supply is used as the core voltage as well as the interface to the memory devices and display. Most of the pins on the Patriot operate from the 2.9-volt supply.

There are two main clocks that are provided to the Patriot:

1. The CKIH pin is provided by a 16.8MHz sine wave; this is the most important clock since it is internally used to generate the clocks for both the MCU and DSP cores, as well as most of the peripherals.
2. A 2.9-volt peak-to-peak 32.768kHz square wave is supplied to the MCU and DSP cores. It is generated by an external 32.768kHz crystal (Y701), and a clock buffer circuit that includes U712, U713, U714, C742, C743, C791, C743, C792, R745, R747, R748, R799, R741 and R742. This signal is supplied to the CKIL pin on the dual-core processor. While not as widely used as the 16.8MHz clock, the 32.768kHz clock is needed by some components in the dual-core processor, including the reset circuitry.

4.2.6.1.1.1 Microcontroller Unit (MCU)

The MCU portion of the Patriot has 22.5Kx32 bits of internal RAM and 1Kx32 bits of internal ROM. The internal ROM is used for the bootstrapping code. The MCU has several peripherals, including the following:

- an External Interface Module (EIM)
- the Multiple Queue Serial Peripheral Interface (MQSPI)
- two Universal Asynchronous Receiver/Transmitter (UART) modules, and
- the One-Wire Interface module.

The MCU communicates internally to the DSP through the MCU/DSP Interface (MDI).

External Interface Module (EIM)

The External Interface Module (EIM) is the MCU's interface to the SRAM (U804), Flash Memory (U803), and the display. The EIM lines include the following:

- 24 external address lines
- 16 external bi-directional data lines
- 6 chip selects lines
- read/write line, and
- output enable line, among others.

All of the EIM lines operate at 1.8-volt logic levels; the EIM operates at the MCU clock speed.

Multiple Queue Serial Peripheral Interface (MQSPI)

The Multiple Queue Serial Peripheral Interface (MQSPI) is the MCU's programming interface to other ICs. The Patriot has two independent SPI busses, and each has its own clock line, data-out line (MOSI), and data-in line (MISO). There are 10 SPI chip selects (SPICS) that are programmable to either SPI A, the RF board's SPI bus, or to SPI B, the dedicated VOCON SPI bus. The devices on the SPI A bus include the following:

- the PCIC and FRACN IC on the SPICS4, and
- the ABACUS III on SPICS5.

There is one SPI B chip select used for the MAKO IC U701 on SPICS2 (TP_MAKO_CE). All of the lines of the SPI module operate at the GPIO voltage logic level (see section 4.2.6.1.1.).

There are several devices on the RF board that only have one bi-directional SPI data line. Components U801, U802, and Q801 are configured by the MCU GPIO pin TOUT13 (MISOA_SEL) to route the data line to the appropriate pin on the Patriot depending on which SPI device is being accessed.

Universal Asynchronous Receiver/Transmitter (UART)

The Patriot has two Universal Asynchronous Receiver/Transmitter (UART) modules. UART1 (primary UART) handles the RS 232 lines while UART 2 is not used. The primary UART has the following lines:

- a receive data line URXD
- a transmit data line UTXD, and
- hardware flow control signals RTS (request to send) and CTS (clear to send).

All UART lines are operating at the GPIO voltage logic level (see section 4.2.6.1.1.).

One-Wire Interface

The MCU has a One-Wire Interface module that is used to communicate to a One-Wire device like a USB cable or a smart battery using the Dallas Semiconductor protocol. This module has one external pin, OWIRE_DAT (U800 pin F6), and it uses the GPIO voltage logic level.

4.2.6.1.1.2 Digital Signal Processor (DSP)

The DSP portion of the Patriot has 84Kx24 bits of program RAM and 62Kx16 bits of data RAM. The DSP has its own set of peripherals including the following:

- the Baseband Interface Port (BBP)
- the DSP Timer module, and
- the Serial Audio Codec Port (SAP).

Additionally, the DSP shares some peripherals with the MCU, including the USB interface and the General Purpose Input/Output module (GPIO).

Baseband Interface Port (BBP)

The Baseband Interface Port (BBP) module is the DSP's serial synchronous interface (SSI) to the RF board. The BBP has independent sections for the receiver and the transmitter. The receiver BBP pins include

- the receive data pin SRDB
- the receive clock signal pin SC0B, and
- the receive frame synchronization (sync) signal pin SC1B.

The transmitter's BBP pins include

- the transmit data pin STDB (R816)
- the transmit clock signal pin SCKB (TCLK test point), and
- the transmit frame sync signal pin SC2B (TSYNC).

All BBP lines use the GPIO voltage level (see section 4.2.6.1.1.).

DSP Timer Module

While the BBP receive clock and frame sync signals are supplied by the ABACUS III from the RF board, the BBP transmit clock and frame sync signals are generated by the MAKO IC using the 16.8MHz clock (connected to the TCXO_IN M1 pin). The BBP transmit clock and frame sync signals, along with the BBP transmit data signal, are connected to the Digital-to-Analog Converter (DAC) on the RF board.

Serial Audio Codec Port (SAP)

The Serial Audio Codec Port (SAP) module is the DSP's serial synchronous interface (SSI) to the audio codec on the MAKO IC. The SAP interface consist of four signals:

- the SAP clock line pin SCKA (CODEC_DCLK, R772)
- the SAP frame sync line pin SC2A (CODEC_FSYNC, R773)
- the SAP receive data line pin SRDA (CODEC_TX, R774), and
- the transmit data line pin STDA (CODEC_RX, R775).

The SAP clock is generated by the MAKO IC, U701, and it is a 512kHz, 2.9-volt peak-to-peak wave. The SAP frame sync signal is also generated by the MAKO IC, U701 and it is an 8 kHz, 2.9-volt peak-to-peak square wave.

Universal Serial Bus (USB)

The Patriot's USB peripheral, shared by the MCU and the DSP, provides the required buffering and protocol to communicate on the Universal Serial Bus. The Patriot supports USB slave functionality.

- For receive data: the receive data is routed from the MAKO IC (U701) integrated USB transceiver. Single ended positive data is generated at U701 pin B9 and is sent to the dual-core processor pin URXD_RTS. USB data minus comes from U701 pin C9 and is sent to URXD1 of the dual-core processor.
- For transmit data: the USB data comes out of the Patriot UTXD1 pin and goes to the MAKO IC pin C8.

General Purpose Input/Output Module (GPIO)

The GPIO (General Purpose Input/Output) Module is shared by the MCU and the DSP. This module consists of four 16-pin bi-directional ports and a 15 pin bi-directional port. While some of these pins on these ports are being used for other functions (UART, SPI, SAP, BBP, and Interrupt pins), the remaining pins on those ports may be programmed to become GPIOs that may be used by either the DSP or the MCU. Each GPIO pin has up to 8 alternate output functions and up to 4 alternate input functions. This allows for the GPIO pins to be routed internally to pertinent Patriot modules. Additionally, the GPIO module adds selectable edge-triggered or level-sensitive interrupt functionality to the GPIO pins. An example of GPIO pins include the following:

- the LED control signals (RED_LED and GREEN_LED).

4.2.6.1.2 SRAM (U804)

The static RAM (SRAM) is an asynchronous, 1 MB CMOS device that is capable of 70 ns access speed. It is supplied with 1.8 volts. The SRAM has 19 address lines and 16 data lines connected to the External Interface Module (EIM) of the Patriot IC through the ADDR(23:0) and DATA(15:0) busses.

The SRAM has an active low chip-select EN_CE that is connected to the EIM CS2_N pin. When the SRAM EN_CE pin is not asserted, the SRAM is in standby mode, which reduces current consumption.

Two other control signals from the EIM that change the mode of the SRAM are the read/write signal (R/W), and the output enable signal (OE). The R/W of the EIM is connected to the SRAM EN_WE pin while the OE signal from the EIM is connected to the SRAM EN_OE pin. The SRAM is in read mode when the EN_WE pin is not asserted and the EN_OE pin is asserted. The SRAM is in write mode when the EN_WE pin is asserted, regardless of the state of the EN_OE pin.

The other SRAM pins are the lower byte enable pin EN_BLE and the upper byte enable pin EN_BHE. These pins are used to determine which byte (EN_BLE controls data lines 0-7 and EN_BHE controls data lines 8-15) is being used when there is a read or a write request from the Patriot. The EN_BLE pin is controlled by the EIM EB1_N signal while the EN_BHE pin is controlled by the EB0_N signal.

4.2.6.1.3 Flash Memory (U803)

The Flash memory IC is a 8-megabyte CMOS device with simultaneous read/write or simultaneous read/erase operation capabilities with 70 ns access speed. It is supplied with 1.8 volts. The Flash memory has its 22 address lines and 16 data lines connected to the EIM of the Patriot IC through the ADDR(23:0) and DATA(15:0) busses. The Flash memory contains host firmware, DSP firmware, codeplug data, and tuning values.

The RESET_OUT of the Patriot IC (U800) is at the GPIO voltage logic level (see section 4.1.6.1.1.). Components CR800 and R812 are used to convert the voltage down to a 1.8-volt logic level, and this 1.8 volt reset signal is fed to the Flash RESET pin. When this pin is asserted (active low logic), the Flash is in reset mode. In this mode, the internal circuitry powers down and the outputs become high impedance connections.

The Flash active low chip select pin, EN_CE, is connected to the active low CS0 pin (TP_CS0 test point) of the EIM. When the EN_CE is not asserted, the Flash is in standby mode which reduces the current consumption.

Several other active low controls pins determine what mode the Flash memory is in:

- the address valid pin ADV which is connected to the EIM LBA signal
- the output enable pin EN_OE that is connected to the EIM OE signal, and
- the write enable pin EN_WE which connected to the EIM EB1 signal.

For read mode, the ADV and EN_OE pins would be asserted while the EN_WE pin would not be asserted. When the EN_WE is asserted and the EN_OE pin is non-asserted, the Flash would operate in the write mode.

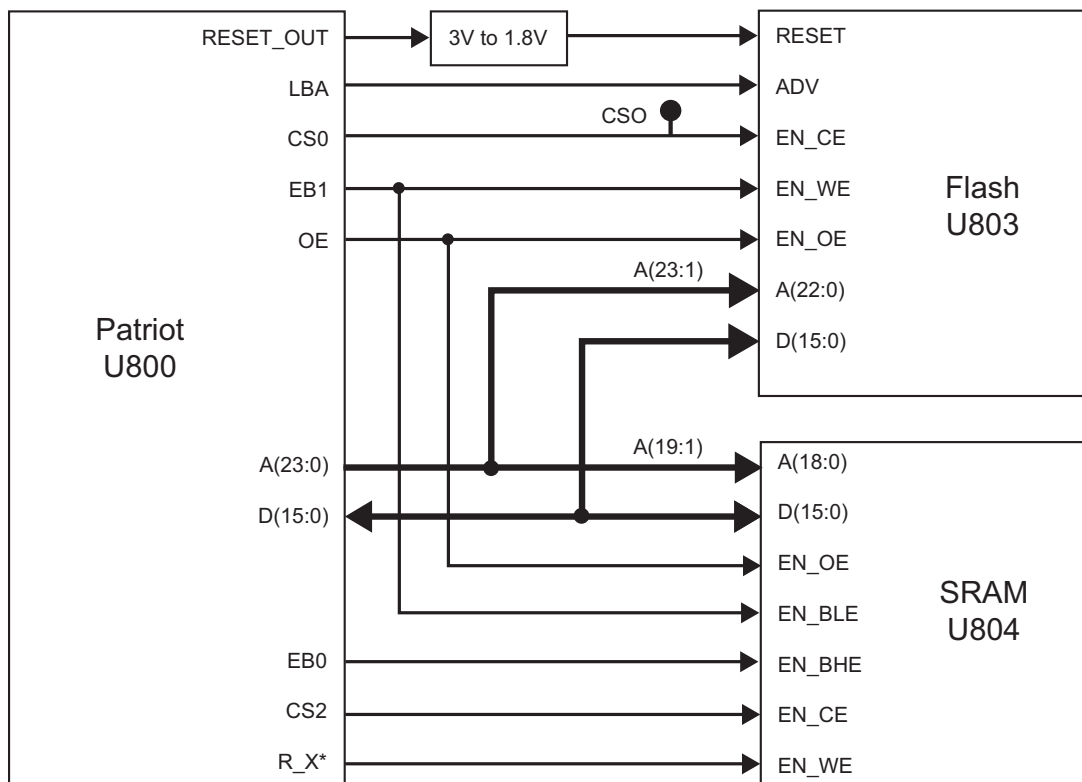

Figure 4.2-1. Controller Memory Interface

4.2.6.2 Audio and Power Section

Two main ICs reside in the audio and power section of the schematic diagram:

- the MAKO IC (U701)
- the VSW1 Driver IC (Q702)

4.2.6.2.1 MAKO IC (U701)

The MAKO IC is a mixed-signal IC that provides control, clock generation, digital support, audio, and voltage regulation functionality. It comes in a 176-pin, ball-grid array (BGA) package with 0.8mm pitch solder balls. The MAKO IC is supplied with switched battery voltage SW_B+.

4.2.6.2.1.1 Voltage Regulation

The MAKO IC contains all of the regulators that are used in the design of the VOCON board:

VSW1, VSW2, V_2.9, V1.55, V1.875, and VCC5. VSW1 is a programmable switching regulator controlled by the MAKO IC on pin SW1_SUMCOMP_DL, while the current is sourced by a driver Q702 using the switched battery voltage (SW_B+). The switching frequency of VSW1 is programmable by the dual-core processor through the SPI bus. The VSW1 voltage is supplied to the input pin of MAKO's VSW2 regulator (pin SW2_VCCS).

The VSW2 regulator is a SPI programmable switching regulator. The initial and programmed output of VSW2 at C715 is 2.3 volts. The VSW2 voltage is used internal to the MAKO IC to supply the 1.875 volt (V1.875) and 1.55 volt (V1.55) linear voltage regulators. The V1.875 voltage at L703 is supplied to the dual-core processor U800 (EIM voltage), SRAM U804, and Flash memory U803. The V1.55 voltage at R718 is supplied to the dual-core processor U800 (core voltage).

The V_2.9 volt regulator is a linear regulator within the MAKO IC that used VSW1 as its input. The initial output of V_2.9 at L704 is 2.775 volts, which is then programmed to 2.9 volts by the dual-core processor via the SPI bus. The V_2.9 voltage is supplied to the dual-core processor (I/O ring - SPI, BBP, SAP, UART, GPIO, etc.), the display module connector J601, and the many discrete components that interface with the dual-core processor and the MAKO IC.

4.2.6.2.1.2 Microcontroller Unit (MCU) Interface

The MAKO IC has a four-wire, SPI connection to the dual-core processor (SPI B). The SPI B clock is connected to the SPI_CLK pin E6. The SPI B MOSI line is connected to the SPI_DI pin B6. The SPI B MISO line is connected to the SPI_DO pin C6. The MAKO SPI B chip-select signal is connected to the SPI_CS pin D6. Through this interface, the dual-core processor can program the voltage regulators, the CODEC, the transmit and receive audio filters and amplifiers, digital support multiplexing, and read information from the ADC.

The MAKO IC has a 10-bit ADC with eight general-purpose channels and two voltage-monitoring channels. Five out of the eight general-purpose channels are assigned to the display backlight button on the control head (ATOD_2), the monitor volume (ATOD_1), the two-position toggle switch (ATOD_3), the OPT_SEL_IN (ATOD_8), and board type ID (ATOD_5). The other three general purpose channels are unused. Battery voltage is also monitored by the ADC. The dual-core processor reads the ADC values through the SPI bus.

4.2.6.2.1.3 Audio Circuitry

A16-bit CODEC is integrated into the MAKO IC and programmable by the dual-core processor through the SPI bus. The CODEC converts microphone audio data into a digital bit stream for processor by the DSP and converts receive audio data that was processed by the DSP into an analog audio signal for amplification to a speaker. The CODEC interfaces to the DSP through the 4-wire SAP bus. The CODEC clock, which is 512kHz, is generated by the MAKO IC and supplied on the VC_DCLK pin (R772). The CODEC 8 kHz frame synchronization signal is generated by the MAKO IC and supplied on the VC_FSYNC pin (R773). The CODEC transmit data signal is on the VC_TX3V pin and the CODEC receive data signal is on the VC_RX pin. For the MAKO IC to generate the clock and frame sync signals, a 24.576 MHz crystal Y702 is supplied to the XOUT and XIN pins.

The MAKO IC contains internal amplification (digital and analog), filtering, and multiplexing functionality for both receive and transmit audio. These functions are programmable by the dual core processor through the SPI bus. The input for the internal microphone audio (C755) is the INT_MIC_P pin, while the input for the external microphone audio (C754) is the EXT_MIC_P pin. The differential output for the internal speaker is the INT_SPKR_P pin and INT_SPKR_M pin. The differential output for the external speaker is the EXT_SPKR_P pin (C769) and EXT_SPKR_M pin (C768).

4.2.6.2.2 Regulator

The 5 V regulator is internal to the MAKO IC and uses SW_B+ as its input voltage at pin V08_I (C720). The 5 V supply (L705) is used by the bi-directional voltage translators integrated into the MAKO IC, the MAKO IC protection diodes, and the ESD protection circuitry.

The 1.55 V regulator (programmable through the SPI bus) is integrated into the MAKO IC. This regulator uses VSW2 to source the current. The 1.55 V supply (R718) is used by the dual-core processor U701 for its core voltage and clock amplifier.

4.2.6.2.3 Audio Pre-Amplifier

The audio pre-amplifier is integrated into the MAKO IC. The pre-amplifier's supply voltage and gain are programmable and controlled by the dual-core processor through the SPI bus. The input to the pre-amplifier is routed from the internal gain stages within the MAKO IC. The differential output of the pre-amplifier is the VC_OUT_P pin (R844) and VC_OUT_M pin (R798).

4.2.6.2.4 Audio Power Amplifier

The audio power amplifier, supplied by SW_B+, is integrated into the MAKO IC U701. The audio PA is a programmable BTL type and is controlled by the dual-core processor through the SPI bus. The operational state of the PA, as well as selecting between the internal and external audio path, is controlled by the dual-core processor via the SPI bus.

The differential input to the audio PA comes from a low-pass filter (R844, R798, C764, C765, and C790) at the output of the audio pre-amplifier.

4.2.6.3 Interface Support Section

The interface support section includes the following:

- the MAKO IC (U701)
- the ESD protection circuitry, and
- the universal connector interface circuitry.

4.2.6.3.1 MAKO IC U701

The digital-support functions are performed by the MAKO IC. The MAKO IC is contained in a 176-pin BGA with 0.8mm pitch solder balls. The MAKO IC is supplied with three clocks. It is supplied with a 16.8 MHz clock from the transceiver board. It uses a 32.768 kHz crystal to boot up the dual core processor and for the real-time clock. It also uses a 24.576 MHz crystal to generate the SAP clock and frame synchronization signals.

The MAKO IC includes that one-wire option detect support, watchdog timer, and the radio's universal (accessory) side connector interface. It also monitors the position of the on/off switch in order to control the power-up/power-down sequence.

4.2.6.3.1.1 Side Connector Interface, Logic Level Translation, and Boot Data Path Control

The LH Data bidirectional translation is performed internal to the MAKO IC and 3V logic level is on MAKO pin SB96D_BDO_KF_3V.

4.2.6.3.1.2 USB Transceiver

The USB transceiver is internal to MAKO IC U701, and is capable of transmitting and receiving serial data at a rate of 12 megabits per second. The differential USB data comes from the side connector, through the 33-ohm resistors R837 and R838 and then to the USB1_DP and USB1_DM pins on U701. The data will then go through some interfacing and multiplexing internal to the transceiver for 6-wire USB operation and onto the output pins. The USB receive interface through the transceiver to the dual core processor is as follows: DP routed to USB_VPI, DM routed to URXD1_USB_VMI, and the differentially decoded data is output on URTS1_XRXD pin.

The USB transmitter is enabled when the RS232_USB* and USB_TXENAB signals are both driven low by the dual-core processor. The single-ended data is output from the dual-core processor on the UTXD1_USB_VPO pin and goes to USB1_DAT_TXD on U701. The data is driven out differentially on the USB1_DP and USB1_DM pins, which go to the side connector. The dual-core processor sends the single-ended zero signal from pin USB_VMO to the USB1_SE0 pin on U701.

When a USB cable is attached, pin CTS_CABLE_DET_5V is driven low and goes through level translation in U701 and the output of CTS_CABLE_DET_3V is pulsed low and sent to the dual-core processor. This line controls the USB and RS232 modes so that the data that is on those lines are routed to the USB transceiver when a cable is detected. If a USB cable is not detected, CTS_CABLE_DET_3V is high, the transceiver is put in suspend mode and the DP and DM pins can now handle 5V tolerance for RS232 mode.

4.2.6.3.1.3 One-Wire Support

New options and accessories that attach to the side connector are identified by the dual-core processor using the One-Wire protocol. The One-Wire pin on the side connector serves as the One-Wire data pin. This signal is connected to the ONE_WIRE_OPT pin. This pin is connected to the dual-core processor One-wire bus ONE_WIRE_UP through the MAKO IC, U701, internal isolation switch controlled by the SPI commands sent from the dual-core processor. This isolation is needed to prevent possible contention on the One-Wire bus when a smart battery is attached to the radio.

These new accessories are to ground, designator R666, of the side connector. When this occurs, the ONE_WIRE_OPT is asserted and the dual-core processor detects the change. The dual-core processor then sends a command through the SPI lines to the U701 MAKO IC to connect the side connector One-Wire line to the dual-core processor One-Wire bus. In the case of the USB cable, the dual-core processor reads the One-Wire data from the cable and, upon determining that a USB cable is attached, programs the digital-support IC for USB mode.

4.2.6.3.1.4 Watchdog Timer

The watchdog timer is a 125ms counter that is integrated into the MAKO IC U701 and used during the power down sequence. The MAKO IC will begin the power down sequence when a low-to-high transition occurs on MECH_SW pin (MAKO pin E4). Once this transition occurs, the MAKO IC begins the watchdog timer. Upon expiration, RESETX (MAKO pin C5) is asserted and all of the MAKO regulators are shutdown. The dual-core processor can refresh the watchdog timer so that the software has enough time to complete its tasks before the power is taken away.

4.2.6.3.1.5 32 kHz Oscillator and CMOS Output

There is an internal 32kHz oscillator circuitry to the MAKO IC U301 that is based off of a 32.768 kHz crystal Y701 and additional load capacitors C701 and C702. The output of the 32 kHz oscillator is a logic_vdd voltage (approximately 2.9 volts peak-to-peak), 32kHz +/- 20% square wave on pin GATED_32K_CLK. This 32 kHz signal is routed through an analog switch U302 and sent to the dual-core processor CKIL pin. This signal is only used to boot up the dual-core processor.

After the dual-core processor boots up, the select input (R799) of the analog switch is asserted high allowing for the processor to receive an accurate 32.768 kHz, 2.9 V peak-to-peak square wave. This signal is generated by tapping the output of the 32.768 crystal and buffering the signal with the following components: U713, R745, R746, C743, C792, R742, and R741. The 32.768 kHz clock signal allows for the completion of real-time applications.

4.2.6.3.2 ESD Protection Circuitry

Several components on the VOCON section were added to protect the circuitry from Electrostatic Discharge (ESD). The side connector signal lines are exposed and require ESD protection components. These protection components include:

- 5.6 volt zeners (VR659 and VR662) on the CTS and RTS lines, microphone lines, and the option select lines
- 12 volt zener (VR650) on the internal and external speaker audio lines
- 13 volt zener (VR658) on the OPTB+ line, and
- low capacitance ESD suppressors (VR678, VR651, and VR652) on the USB data lines.

4.2.6.3.3 Universal Connector (Side Connector) Interface Circuitry

An important circuit in the side connector interface is the Option Select 2 line comparator. The op-amp (U601) is used as a comparator for the option select 2 line. The voltage divider network of R658 and R673 determines the comparator threshold. The remaining components on the side connector interface consist of current-limiting serial resistors and noise-suppressing shunt capacitors.

4.2.6.3.3.1 Universal Connector (Side Connector) and Option Selects

The universal connector is located on the side of the radio. It is the external port or interface to the outside, and is used for programming and interfacing to external accessories. The universal connector is connected to the main board via a flex circuit at connector J650.

Most of the signals are extensions of circuits described in other areas of this manual. However, there are two option select pins used to configure special modes: Option Select 1 and Option Select 2. These pins are controlled by accessories connected to the universal connector. Connections to the universal connector and J650 are shown in Figure 4.2-2. and Figure 4.2-3., respectively.

Table 4.2-1 outlines their functions as defined at the universal connector.

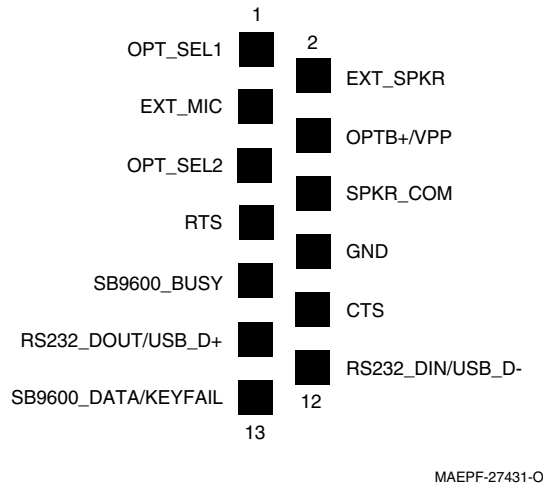

Figure 4.2-2. Universal (Side) Connector

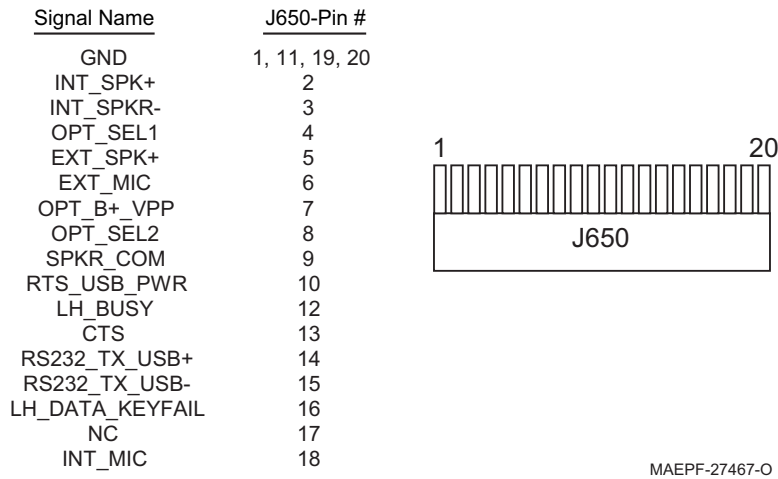

Figure 4.2-3. VOCON Connector J650

Table 4.2-1. Option Select Functions

FUNCTION	Option Select 1	Option Select 2
External PTT	0	0
No Function (Normal)	1	1
Man Down	1	0
External Speaker	0	1

4.2.6.3.4 The Option Board

The Option Board consists of the "keypad module" and the "display module" for models II and III of the XTS 2500/XTS 2500I radio.

4.2.6.3.4.1 Display Module

An optional integral 96 pixels by 64 pixels LCD display module is available with either a 3 x 2 keypad with a navigational button (Model II radios), or 3 x 6 keypad with a navigational button (Model III radios). This unit is not considered field-repairable. The display module is connected to the VOCON section through the flex connector (J900).

The display is controlled by the Patriot's MCU core. The MCU core programs the display through the following:

- EIM data lines D0 - D7 (pins 9 through 16, respectively),
- the display chip select line (pin 5),
- the EIM "write only" line (pin 8), and
- the EIM address 0 line (pin 7).

The EIM address 0 is used to select the register to be programmed. The Patriot may reset the display module through pin 6. The display is supplied with 1.8 volts (C901) to pin 17 and 3 volts (C902) to pin 18.

The Patriot GPIO BL_EN controls the display backlighting; that signal goes to pin 43 of the J601 connector (on the radio board), and the corresponding pin 3 of the J901 connector (on the Option board).

Pin 4 of the J601 connector (on the radio board), and the corresponding pin 42 on the J901 connector (on the Option board) is supplied with 7.5 volts. The 7.5 volts is used to power the LEDs on the display module.

Pin 2 of the J601 connector (on the radio board), and the corresponding pin 44 on the J901 connector (on the Option board), is supplied with the V2 regulated voltage. The V2 regulated voltage is used to power DISPLAY_VCC.

Pin 1 of the J601 connector (on the radio board), and the corresponding pin 45 on the J901 connector (on the Option board), is supplied with 1.8 volts. The 1.8 volts is used to power DISPLAY_VDD.

4.2.6.3.4.2 Keypad Module

The keypad module is connected to the main board through flex connector (J601) on the radio board schematic and J901 on the Option board schematic. The keypad is read through a row-and-column matrix made up of ROW0, ROW1, ROW2, ROW3, ROW4, ROW5, ROW6 and COL0, COL1, and COL2. This totals 18 keys on the keypad. When a key is pressed, a row and a column are connected to one another.

The Patriot determines a key press by a scanning algorithm. Each column line is configured as an open drain output and pulled low. The Patriot then scans the row pins (each row pin has an internal pull up resistor). If a row signal is read low, then the Patriot determines that a key was pressed. If none of the row signal lines are low, then another column line is pulled low and the row scanning routine occurs.

The Patriot GPIO BL_EN controls the keypad backlighting; that signal goes to pin 43 of the J601 connector (on the radio board), and the corresponding pin 3 of the J901 connector (on the Option board). Pin 42 is supplied with 7.5 volts, which is used to power the LEDs on the keypad module.

4.2.6.3.5 Encryption Module

The encryption module (secure models only) connects directly to the VOCON board and interfaces directly with the vocoder digital circuitry. It contains one custom microcontroller IC (Armour) to perform digital, numerical, encryption algorithms.

The encryption modules are designed to digitally encrypt and decrypt voice for ASTRO and NON-ASTRO in XTS 2500/XTS 2500I. This section covers the encryption modules, hardware kits **0104020J49 (Model 1.5)**, **0104020J50 (Model 2)** and **0104020J51 (Model 3)**.

NOTE: The encryption modules are NOT serviceable. The information contained in this section is only intended to help determine whether a problem is due to an encryption module or the radio itself.

The encryption module uses a custom encryption IC and an encryption key variable to perform its encode/decode function. The encryption key variable is loaded into the encryption module, via the radio's universal (side) connector, from a hand-held, key variable loader (KVL). The encryption IC corresponds to the particular encryption algorithm purchased. [Table 4.2-2](#) lists the encryption algorithms and their corresponding kit numbers.

The encryption module operates from two power supplies (UNSW_B+ and SW_B+). The SW_B+ is turned on and off by the radio's On/Off switch. The UNSW_B+ provides power to the encryption module as long as the radio battery is in place.

Key variables are loaded into the encryption module through connector J601, pin 34. Depending on the type of encryption module, up to 16 keys can be stored in the module at a time. The key can be infinite key retention or 30-seconds key retention, depending on how the codeplug is set up.

The radio's host processor communicates with the encryption module on the Synchronous Serial Interface (SSI) bus. The SSI bus consists of four signal lines. A communications failure between the host processor and the secure module will be *ERROR 09/10* or *S03 error* message on the display.

To troubleshoot the encryption module, refer to the flowcharts in [Chapter 6.2 "UHF1 Troubleshooting Charts."](#)

Table 4.2-2. Encryption Module Software Kits and Algorithms

Software Kit Number	Algorithm
Q667AB (7/800), Q667AE (V,U1,U2)	ADP SFWR DSP BASED CRYPTO
Q159AC	XTS 2500/XTS 2500I UCM HARDWARE ENCRYPTION
Q629AD	AES ENCRYPTION
Q625AU	DES, DES-XL, DES-OFB ENCRYPTION
Q668AC	ADP UCM ENCRYPTION W/DES, DES-XL, DES-OFB
H869BQ	MULTI KEY
Q406AC	ADP UCM ENCRYPTION
QA00204AA	MULTIKEY AND ADP
	ADP UCM ENCRYPTION W/AES

4.2.6.3.6 System Clocks

The Patriot is supplied with two clocks:

1. The first clock, a 16.8 MHz sine wave, comes from the RF portion of the radio. It is conditioned by the clock buffer circuit, which includes Q709, R722, R740, R743, R729, R797, C726, C725 and C727.
2. The other clock supplied to Patriot is a 32.768 kHz square wave. This clock is generated by the external 32.768kHz crystal Y701, and a clock buffer circuit that includes U713, R745, R746, C743, C792, R742 and R741. This signal is supplied to the CKIL pin on the dual-core processor.

4.2.6.4 Transmit Audio Path

Refer to [Figure 4.2-4](#). The single-ended internal microphone audio enters the VOCON board through 20 pin side connector (J650), and the internal microphone bias is set by circuitry that includes R751, R753, C751, C753 and C755. The internal microphone signal is connected to the INT_MIC_P pin, which is the input terminal on the MAKO IC internal op-amp G1 after the signal is multiplexed. The gain of the G1 pre-amp is set to +15 dB, which is programmed by dual-core processor SPI lines.

The external microphone audio enters the VOCON board through the remote connector J102, pin10, and the external microphone bias is set by circuitry that includes R750, R752, C750, C752 and C754. The external microphone signal is connected to the EXT_MIC_P pin, which is an input terminal on the MAKO IC internal op-amp G1 after the signal is multiplexed. The gain of the G1 pre-amp is set to +15 dB, which is programmed by dual-core processor SPI lines.

The dual-core processor, through the SPI bus, programs a multiplexer internal to the MAKO IC to select one of the microphone signals. Then, the selected microphone signal goes through the G1 pre-amplifier stage and on to a programmable gain amplifier (G2) before it goes to the CODEC for A/D conversion. The resulting digital data is filtered and sent to the DSP on the CODEC_TX line from the MAKO IC VC_TX3V pin. After additional filtering and processing, the DSP sends the data-out from the STDB pin, labeled TX_SSI_DATA to the RF interface connector.

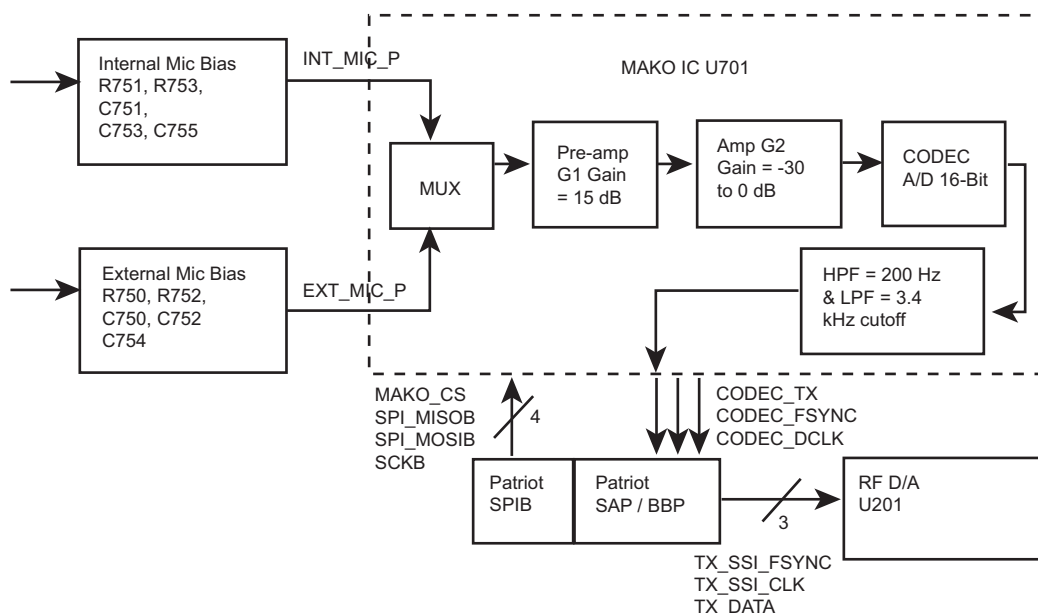

Figure 4.2-4. VOCON Transmit Audio Path

4.2.6.5 Receive Audio Path

Refer to [Figure 4.2-5](#). The receive audio data comes from the Abacus III IC U401 (DOUTA) to the dual-core processor SRDB pin. The DSP decodes the data and sends it out through the CODEC_RX line to the MAKO IC VC_RX3V pin. The CODEC filters, adds digital programmable gain G1, then converts the digital data into an analog audio signal, which in turn is sent to programmable attenuator G3. The signal is then sent through an internal programmable differential preamplifier (G4) to add gain and outputs the signal on pins VC_OUT_P and VC_OUT_M of the MAKO IC.

This output from the preamp is then filtered through circuitry R798, R844, C764, C765, C790, and then sent back to 2 independent internal BTL differential power amplifiers, G5 & G6, of the MAKO IC. The power amplifiers are programmed to a fixed gain of 26 dB through the dual-core processor SPI lines and PA control registers.

The dual-core processor selects whether the amplified audio is routed to the internal speaker or the external speaker through the SPI lines based upon which amplifier is turned on as shown in the PA control block. The output audio is routed on MAKO IC pins INT_SPKR_P and INT_SPKR_M for internal and EXT_SPKR_P and EXT_SPKR_M for external speaker lines.

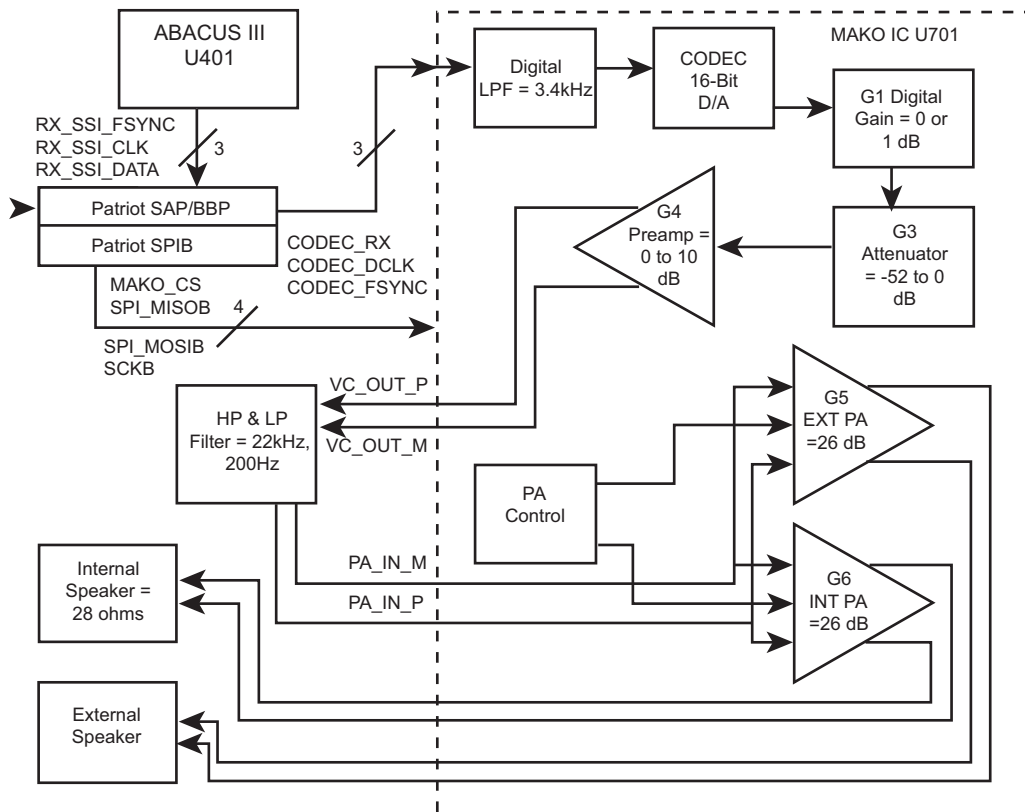

Figure 4.2-5. VOCON Receive Audio Path

Chapter 4.3 UHF2 Detailed Theories of Operation

4.3.1 Introduction

This chapter provides a detailed circuit description of the ASTRO XTS 2500/XTS 2500I/XTS 2250/XTS 1500 radio board. When reading the theory of operation, refer to the appropriate schematic and component location diagrams located in the back of this manual. This detailed theory of operation can help isolate the problem to a particular component.

This manual is to be used in conjunction with the ASTRO XTS 2500, XTS 2500I, XTS 2250, XTS 1500, MT 1500 Digital Portable Radios Basic Service Manual (Motorola part number 6816984H01), which uses the pass/fail service approach to radio problems.

4.3.2 Frequency Synthesis

For UHF Range 2 (450-520 MHz), the complete synthesizer subsystem consists of the following:

- The **reference oscillator** (Y200)
- Two **voltage-controlled oscillators** (TX and RX)
- One **voltage-controlled oscillator buffer IC** (U250)
- The **synthesizer** (U202)

The reference oscillator contains a temperature-compensated 16.8 MHz crystal. This oscillator is digitally tuned and contains a temperature-referenced, six-bit, analog-to-digital (A/D) converter. The output of the oscillator (pin 3 on Y200) is applied to pin 23 (XTAL1) of U202 through capacitor C214.

The voltage-controlled oscillators (VCOs) are varactor-tuned. The voltage (2-9.5V) varies as it is being applied to varactors D251 to D254 and D270 to D273 of their respective VCO. The capacitance of the varactors also varies, thereby changing the output frequency of the VCOs. Both VCOs are used to cover the entire 70 MHz bandwidth of this UHF range (450-520 MHz):

- TX VCO covers the transmit frequencies from 450-520 MHz
- RX VCO covers the receive frequencies from 376.65-446.65 MHz

The TX and RX VCOs are selected using AUX 3 from U202. Both VCOs are connected to the same prescaler filter (C292, L266 and R266) feeding back to PREIN of the U202, through C293.

The synthesizer IC consists of the following:

- A prescaler
 - A programmable loop divider
 - A divider logic control
 - A phase detector
 - A charge pump
 - An A/D converter for low-frequency digital modulation
 - A balance attenuator to balance the high-frequency analog modulation to the low-frequency digital modulation
 - A 13V positive voltage multiplier
 - A serial interface for control
 - A filter for the regulated 5 and 3 volts
-

The 13V, being generated by the positive voltage multiplier circuitry, should be present at pin 47 of U202. The serial interface (SRL) is connected to the microprocessor via the data line (pin 7 of U202), the clock line (pin 8 of U202), and the chip-enable line (pin 9 of U202).

The complete synthesizer subsystem works as follows:

1. The buffered output of the VCO is present at R294 in receive mode and R275 during transmit mode.
2. The output of the prescaler filter is present at C293 and applied to pin 32 of U202. The prescaler in U202 is a dual-modulus type with selectable divider ratios. This divider ratio is controlled by the loop divider, which in turn receives its input from the SRL. The loop divider adds or subtracts phase to the prescaler divider by changing the divider ratio via the modulus control line.
3. The output of the prescaler is then applied to the loop divider.
4. The output of the loop divider then feeds the phase detector. The phase detector will compare the loop divider's output signal from the VCOs. The VCO signal is divided down after it is applied to pin 32 of U202. The result of the comparison is a pulsed DC signal which is applied to the charge pump.
5. The charge pump outputs a current that will be present at pin 43 of U202. The loop filter consisting of R202, C202, R203, C203, R201, C201, C236, C237, C238, C239 and C240 will convert this current into a voltage that will be applied to varactors D251, D252, D253, D254, D270, D271, D272, and D273 to alter the output frequency of the VCO.

In order to modulate the PLL, the following two-port modulation method is utilized: The analog modulating signal is applied to (1) the A/D converter as well as to (2) the balance attenuator:

1. The A/D converter converts the low-frequency analog modulating signal into a digital code. When the digital code is applied to the loop divider, it causes the carrier to deviate.
2. The balance attenuator is used to adjust the VCO's deviation sensitivity to high-frequency modulating signals.

4.3.3 Antenna Switch

An electronic PIN diode switch steers RF between the receiver and transmitter. The common node of the switch is at capacitors C171 and C180 for UHF Range 2.

1. In transmit mode:
 - a. RF is routed to the anode of diode D170.
 - b. Bias current, sourced from RAW_B+ is routed through PIN diodes D170 and D171, biasing them to a low-impedance state.
2. In receive mode:
 - a. RF is routed through C179 to pre-selector filter.
 - b. PIN diodes D170 and D171 are unbiased and thus at high impedance.

4.3.4 Receiver

The receiver consists of the following:

- Front end
- Back end

4.3.4.1 Front End

For the purposes of this discussion, the receiver front end is defined as being the circuitry from the antenna switch to the output of the IF crystal filter. The UHF2 front end converts the received RF signal to the 1st IF frequency of 73.35 MHz, while at the same time providing for spurious immunity and adjacent channel selectivity. A review of the inter-stage components of the front end follows, with emphasis on troubleshooting considerations.

The received RF signal is passed through quarter wavelength components C180, L176, and C178, (which are anti-resonant at the radio's transmitter frequencies). Both PIN diodes D170 and D171 must be reverse biased to properly route the received RF signal.

Next is the step attenuator (U2). This attenuator provides 15 dB step attenuation to protect the receiver from strong RF signals. The attenuator is controlled by a DSP-based algorithm that continuously monitors signal strength. When the ON threshold is exceeded (approximately -95 dBm), the attenuator is activated via a DAC in the PCIC by the host. The attenuator remains activated until the signal drops below the OFF threshold (approximately -115 dBm including the 15 dB attenuation). Hysteresis and timer functions are included in the algorithm to enhance performance. The algorithm controlling the attenuator is enabled via the CPS for each personality. When the algorithm is disabled, the attenuator is essentially a short circuit from input to output.

The step following the step attenuator is the varactor-tuned preselector filter made up of C1, C2, C3, C4, C5, L1, L2, C63, C64, CR1 and CR2. The preselector is positioned right after the antenna switch to provide the receiver preamp with some protection against strong signal, out-of-band signals, and first-image suppression.

After the preselector filter, the received signal is applied to the receiver preamp, Q29. The preamp is a transistor, which has been biased and matched for optimum intermodulation (IM), noise figure (NF), and gain performance. Components L3 and C7 match the input of the amp to the step attenuator output. The preamp is supplied by a 5V analog regulator and is biased at approximately 0.75Vdc at the base and 2Vdc at the collector.

The output of the amp is matched to a second two-pole preselector filter of the type previously discussed. The match is via C35 and L31. The subsequent stage in the receiver chain is the 1st mixer U1, which uses high-side injection, to convert the RF carrier to an intermediate frequency (IF) of 73.35 MHz. Since high-side injection is used, the LO frequency is offset above the RF carrier by 73.35 MHz, or $f_{LO} = f_{RF} + 73.35 \text{ MHz}$. The mixer utilizes GaAs technology in a double-balanced, Gilbert Cell configuration.

A balun transformer (T51) is used to couple the RF signal into the mixer. The primary winding of T51 is matched to the preceding stage by L57, C51 and C90. The secondary winding of T51 provides a differential output. The center tap pin is grounded via an 75-ohm resistor that sets the mixer bias current.

The final stage in the receiver front end is a two-pole crystal filter (FL51). The crystal filter provides some of the receiver's adjacent channel selectivity and intermodulation. The crystal filter provides at least 75dB of second image protection and improves IM distortion in the ABACUS III IC.

4.3.4.2 Back End

In the **ABACUS IC (U401)**, the first IF frequency is amplified and then down-converted to the second IF frequency (2.25 MHz). At this point, the analog signal is converted into two digital bit streams by a sigma-delta A/D converter. The bit streams are then digitally filtered, mixed down to baseband, and filtered again. The output data stream is then sent to the Patriot IC, where it is decoded to produce the recovered audio.

The ABACUS IC (U401) is electronically programmable. The amount of filtering, which is dependent on the radio channel spacing and signal type, is controlled by the microcomputer. Additional filtering, which used to be provided externally by a conventional ceramic filter, is replaced by internal digital filters in the ABACUS IC.

The ABACUS IC contains a feedback Automatic Gain Control (AGC) circuit to expand the dynamic range of the sigma-delta converter. The differential output data contains the quadrature (I and Q) information in 16-bit words, the AGC information in a 9-bit word, imbedded word sync information, and fill bits. Two synthesizers are available on the chip for second LO and sampling clock (18 MHz) generation.

The second LO/VCO is a Colpitts oscillator built around transistor Q401. Varactor diode (D402) in the VCO is used to adjust the VCO frequency. The control signal for the varactor is derived from a loop filter consisting of C440, R417, C441, R418, and C480. The sampling clock is derived from a negative resistance generator (on the chip) available at CLKP, CLKN, and an external tank circuit (L403, C423, and D401). The loop filter for the clock is realized by C448, R408, and C425.

4.3.5 Transmitter

The RF power amplifier (PA) consists of

- an RF driver (**U101**) and
- a Silicon N-Channel MOSFET type transistor RF power amplifier (**Q101**).

RF input drive level of approximately +3dBm is supplied from the transmit VCO buffer. This input drive level is applied to pin 16 (RFIN) of **U101**. The dc power is applied to pins 6, 7, and 14 of **U101** and to the drain of **Q101** via a filtered RAW_B+. Power control is achieved by varying the dc bias (and thus the gain) at pin 1 of **U101** and the gate of **Q101**. The amplified RF signal leaves the RF final PA (**Q101**) at the drain and is applied to the discrete directional coupler via an impedance match. The RF signal passes through the coupler, a discrete antenna switch, and a discrete harmonic filter before finally reaching the antenna launch connector.

A portion of the forward RF power is sampled by the directional coupler, applied to the diode (D172) for rectification, and the resulting dc signal is fed back to pin 1 of the Power Control IC (PCIC, U102). This dc signal is representative of the forward RF power being passed through the directional coupler. The dc signal is used by the PCIC to regulate the transmitted RF power level.

The PCIC is the heart of the power control loop. The rectified feedback is internally compared to an internal Digital-to-Analog Converter (DAC) output voltage in the PCIC to determine the amount of DC bias voltage at pin 4. This voltage at pin 4 of the PCIC controls the gain (and thus the output power, as explained above) of the RF driver (**U101**) and the RF power amplifier (**Q101**) via a fixed resistor divider network.

U103 senses the temperature of the printed circuit board (PCB) near the RF Power Amplifier (**Q101**) and provides a dc level representative of this temperature to pin 30 of the PCIC. The PCIC uses this input to cut back the output power level after a certain temperature threshold is reached. This ensures (1) radio integrity while transmitting in extreme ambient conditions hotter than the radio's operating temperature range and (2) acts as a safety feature to prevent any thermal runaway fault conditions.

Pin 32 of the PCIC powers the Temperature Sense IC (U103) and forward biases the antenna switch diodes (D170 and D171) while the radio is in transmit mode. This routes the RF signal from the transmitter to the antenna, as explained above. The antenna switch diodes are not biased during receive and standby modes; therefore, any RF signal present at the antenna is applied to the receiver.

4.3.6 VOCON Functional Blocks

The three main functional blocks of the VOCON section consist of the following sections:

- the Controller and Memory Section, consisting of the following components:
 - the Patriot IC (U800)
 - the dual-core processor with the microcontroller unit (MCU) and a digital signal processor (DSP)
 - the SRAM IC (U804) and FLASH IC (U803) memory devices.
- the Audio and Power Section and digital support are all embedded into the MAKO IC (U701).
- the Interface Support Section, consisting of the following components:
 - the ESD protection circuitry
 - the side connector interface circuitry, and
 - the Option board.

4.3.6.1 Controller and Memory Section

Three main ICs are in the controller and memory section of the main board schematic: the Patriot IC (U800), the static RAM (SRAM) (U804), and the Flash memory (U803).

4.3.6.1.1 Patriot IC (U800)

The Patriot IC (U800) is a dual-core processor containing both a 32-bit microcontroller unit (MCU) and a 16-bit digital signal processor (DSP) in one IC package. It comes in a 256 pin, ball grid array (BGA) package with 1mm pitch solder balls. The Patriot is supplied with two voltages: 1.875 volts (E801) and 2.9 volts (E800). The 1.875-volt supply is used as the core voltage as well as the interface to the memory devices and display. Most of the pins on the Patriot operate from the 2.9-volt supply.

There are two main clocks that are provided to the Patriot:

1. The CKIH pin is provided by a 16.8MHz sine wave; this is the most important clock since it is internally used to generate the clocks for both the MCU and DSP cores, as well as most of the peripherals.
2. A 2.9-volt peak-to-peak 32.768kHz square wave is supplied to the MCU and DSP cores. It is generated by an external 32.768kHz crystal (Y701), and a clock buffer circuit that includes U712, U713, U714, C742, C743, C791, C743, C792, R745, R747, R748, R799, R741 and R742. This signal is supplied to the CKIL pin on the dual-core processor. While not as widely used as the 16.8MHz clock, the 32.768kHz clock is needed by some components in the dual-core processor, including the reset circuitry.

4.3.6.1.1.1 Microcontroller Unit (MCU)

The MCU portion of the Patriot has 22.5Kx32 bits of internal RAM and 1Kx32 bits of internal ROM. The internal ROM is used for the bootstrapping code. The MCU has several peripherals, including the following:

- an External Interface Module (EIM)
- the Multiple Queue Serial Peripheral Interface (MQSPI)
- two Universal Asynchronous Receiver/Transmitter (UART) modules, and
- the One-Wire Interface module.

The MCU communicates internally to the DSP through the MCU/DSP Interface (MDI).

External Interface Module (EIM)

The External Interface Module (EIM) is the MCU's interface to the SRAM (U804), Flash Memory (U803), and the display. The EIM lines include the following:

- 24 external address lines
- 16 external bi-directional data lines
- 6 chip selects lines
- read/write line, and
- output enable line, among others.

All of the EIM lines operate at 1.8-volt logic levels; the EIM operates at the MCU clock speed.

Multiple Queue Serial Peripheral Interface (MQSPI)

The Multiple Queue Serial Peripheral Interface (MQSPI) is the MCU's programming interface to other ICs. The Patriot has two independent SPI busses, and each has its own clock line, data-out line (MOSI), and data-in line (MISO). There are 10 SPI chip selects (SPICS) that are programmable to either SPI A, the RF board's SPI bus, or to SPI B, the dedicated VOCON SPI bus. The devices on the SPI A bus include the following:

- the PCIC and FRACN IC on the SPICS4, and
- the ABACUS III on SPICS5.

There is one SPI B chip select used for the MAKO IC U701 on SPICS2 (TP_MAKO_CE). All of the lines of the SPI module operate at the GPIO voltage logic level (see section 4.3.6.1.1.).

There are several devices on the RF board that only have one bi-directional SPI data line. Components U801, U802, and Q801 are configured by the MCU GPIO pin TOUT13 (MISOA_SEL) to route the data line to the appropriate pin on the Patriot depending on which SPI device is being accessed.

Universal Asynchronous Receiver/Transmitter (UART)

The Patriot has two Universal Asynchronous Receiver/Transmitter (UART) modules. UART1 (primary UART) handles the RS 232 lines while UART 2 is not used. The primary UART has the following lines:

- a receive data line URXD
- a transmit data line UTXD, and
- hardware flow control signals RTS (request to send) and CTS (clear to send).

All UART lines are operating at the GPIO voltage logic level (see section 4.3.6.1.1.).

One-Wire Interface

The MCU has a One-Wire Interface module that is used to communicate to a One-Wire device like a USB cable or a smart battery using the Dallas Semiconductor protocol. This module has one external pin, OWIRE_DAT (U800 pin F6), and it uses the GPIO voltage logic level.

4.3.6.1.1.2 Digital Signal Processor (DSP)

The DSP portion of the Patriot has 84Kx24 bits of program RAM and 62Kx16 bits of data RAM. The DSP has its own set of peripherals including the following:

- the Baseband Interface Port (BBP)
- the DSP Timer module, and
- the Serial Audio Codec Port (SAP).

Additionally, the DSP shares some peripherals with the MCU, including the USB interface and the General Purpose Input/Output module (GPIO).

Baseband Interface Port (BBP)

The Baseband Interface Port (BBP) module is the DSP's serial synchronous interface (SSI) to the RF board. The BBP has independent sections for the receiver and the transmitter. The receiver BBP pins include

- the receive data pin SRDB
- the receive clock signal pin SC0B, and
- the receive frame synchronization (sync) signal pin SC1B.

The transmitter's BBP pins include

- the transmit data pin STDB (R816)
- the transmit clock signal pin SCKB (TCLK test point), and
- the transmit frame sync signal pin SC2B (TSYNC).

All BBP lines use the GPIO voltage level (see section 4.3.6.1.1.).

DSP Timer Module

While the BBP receive clock and frame sync signals are supplied by the ABACUS III from the RF board, the BBP transmit clock and frame sync signals are generated by the MAKO IC using the 16.8MHz clock (connected to the TCXO_IN M1 pin). The BBP transmit clock and frame sync signals, along with the BBP transmit data signal, are connected to the Digital-to-Analog Converter (DAC) on the RF board.

Serial Audio Codec Port (SAP)

The Serial Audio Codec Port (SAP) module is the DSP's serial synchronous interface (SSI) to the audio codec on the MAKO IC. The SAP interface consist of four signals:

- the SAP clock line pin SCKA (CODEC_DCLK, R772)
- the SAP frame sync line pin SC2A (CODEC_FSYNC, R773)
- the SAP receive data line pin SRDA (CODEC_TX, R774), and
- the transmit data line pin STDA (CODEC_RX, R775).

The SAP clock is generated by the MAKO IC, U701, and it is a 512kHz, 2.9-volt peak-to-peak wave. The SAP frame sync signal is also generated by the MAKO IC, U701 and it is an 8 kHz, 2.9-volt peak-to-peak square wave.

Universal Serial Bus (USB)

The Patriot's USB peripheral, shared by the MCU and the DSP, provides the required buffering and protocol to communicate on the Universal Serial Bus. The Patriot supports USB slave functionality.

- For receive data: the receive data is routed from the MAKO IC (U701) integrated USB transceiver. Single ended positive data is generated at U701 pin B9 and is sent to the dual-core processor pin URXD_RTS. USB data minus comes from U701 pin C9 and is sent to URXD1 of the dual-core processor.
- For transmit data: the USB data comes out of the Patriot UTXD1 pin and goes to the MAKO IC pin C8.

General Purpose Input/Output Module (GPIO)

The GPIO (General Purpose Input/Output) Module is shared by the MCU and the DSP. This module consists of four 16-pin bi-directional ports and a 15 pin bi-directional port. While some of these pins on these ports are being used for other functions (UART, SPI, SAP, BBP, and Interrupt pins), the remaining pins on those ports may be programmed to become GPIOs that may be used by either the DSP or the MCU. Each GPIO pin has up to 8 alternate output functions and up to 4 alternate input functions. This allows for the GPIO pins to be routed internally to pertinent Patriot modules. Additionally, the GPIO module adds selectable edge-triggered or level-sensitive interrupt functionality to the GPIO pins. An example of GPIO pins include the following:

- the LED control signals (RED_LED and GREEN_LED).

4.3.6.1.2 SRAM (U804)

The static RAM (SRAM) is an asynchronous, 1 MB CMOS device that is capable of 70 ns access speed. It is supplied with 1.8 volts. The SRAM has 19 address lines and 16 data lines connected to the External Interface Module (EIM) of the Patriot IC through the ADDR(23:0) and DATA(15:0) busses.

The SRAM has an active low chip-select EN_CE that is connected to the EIM CS2_N pin. When the SRAM EN_CE pin is not asserted, the SRAM is in standby mode, which reduces current consumption.

Two other control signals from the EIM that change the mode of the SRAM are the read/write signal (R/W), and the output enable signal (OE). The R/W of the EIM is connected to the SRAM EN_WE pin while the OE signal from the EIM is connected to the SRAM EN_OE pin. The SRAM is in read mode when the EN_WE pin is not asserted and the EN_OE pin is asserted. The SRAM is in write mode when the EN_WE pin is asserted, regardless of the state of the EN_OE pin.

The other SRAM pins are the lower byte enable pin EN_BLE and the upper byte enable pin EN_BHE. These pins are used to determine which byte (EN_BLE controls data lines 0-7 and EN_BHE controls data lines 8-15) is being used when there is a read or a write request from the Patriot. The EN_BLE pin is controlled by the EIM EB1_N signal while the EN_BHE pin is controlled by the EB0_N signal.

4.3.6.1.3 Flash Memory (U803)

The Flash memory IC is a 8-megabyte CMOS device with simultaneous read/write or simultaneous read/erase operation capabilities with 70 ns access speed. It is supplied with 1.8 volts. The Flash memory has its 22 address lines and 16 data lines connected to the EIM of the Patriot IC through the ADDR(23:0) and DATA(15:0) busses. The Flash memory contains host firmware, DSP firmware, codeplug data, and tuning values.

The RESET_OUT of the Patriot IC (U800) is at the GPIO voltage logic level (see section 4.1.6.1.1). Components CR800 and R812 are used to convert the voltage down to a 1.8-volt logic level, and this 1.8 volt reset signal is fed to the Flash RESET pin. When this pin is asserted (active low logic), the Flash is in reset mode. In this mode, the internal circuitry powers down and the outputs become high impedance connections.

The Flash active low chip select pin, EN_CE, is connected to the active low CS0 pin (TP_CS0 test point) of the EIM. When the EN_CE is not asserted, the Flash is in standby mode which reduces the current consumption.

Several other active low controls pins determine what mode the Flash memory is in:

- the address valid pin ADV which is connected to the EIM LBA signal
- the output enable pin EN_OE that is connected to the EIM OE signal, and
- the write enable pin EN_WE which connected to the EIM EB1 signal.

For read mode, the ADV and EN_OE pins would be asserted while the EN_WE pin would not be asserted. When the EN_WE is asserted and the EN_OE pin is non-asserted, the Flash would operate in the write mode.

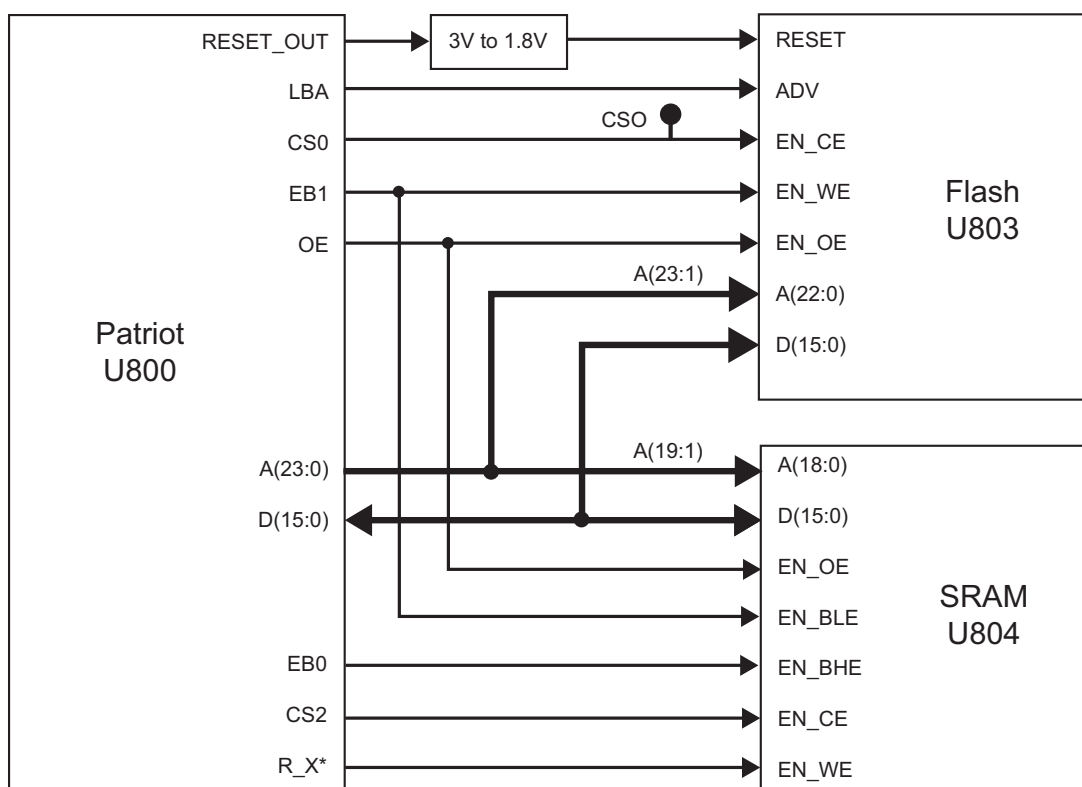

Figure 4.3-1. Controller Memory Interface

4.3.6.2 Audio and Power Section

Two main ICs reside in the audio and power section of the schematic diagram:

- the MAKO IC (U701)
- the VSW1 Driver IC (Q702)

4.3.6.2.1 MAKO IC (U701)

The MAKO IC is a mixed-signal IC that provides control, clock generation, digital support, audio, and voltage regulation functionality. It comes in a 176-pin, ball-grid array (BGA) package with 0.8mm pitch solder balls. The MAKO IC is supplied with switched battery voltage SW_B+.

4.3.6.2.1.1 Voltage Regulation

The MAKO IC contains all of the regulators that are used in the design of the VOCON board:

VSW1, VSW2, V_2.9, V1.55, V1.875, and VCC5. VSW1 is a programmable switching regulator controlled by the MAKO IC on pin SW1_SUMCOMP_DL, while the current is sourced by a driver Q702 using the switched battery voltage (SW_B+). The switching frequency of VSW1 is programmable by the dual-core processor through the SPI bus. The VSW1 voltage is supplied to the input pin of MAKO's VSW2 regulator (pin SW2_VCCS).

The VSW2 regulator is a SPI programmable switching regulator. The initial and programmed output of VSW2 at C715 is 2.3 volts. The VSW2 voltage is used internal to the MAKO IC to supply the 1.875 volt (V1.875) and 1.55 volt (V1.55) linear voltage regulators. The V1.875 voltage at L703 is supplied to the dual-core processor U800 (EIM voltage), SRAM U804, and Flash memory U803. The V1.55 voltage at R718 is supplied to the dual-core processor U800 (core voltage).

The V_2.9 volt regulator is a linear regulator within the MAKO IC that used VSW1 as its input. The initial output of V_2.9 at L704 is 2.775 volts, which is then programmed to 2.9 volts by the dual-core processor via the SPI bus. The V_2.9 voltage is supplied to the dual-core processor (I/O ring - SPI, BBP, SAP, UART, GPIO, etc.), the display module connector J601, and the many discrete components that interface with the dual-core processor and the MAKO IC.

4.3.6.2.1.2 Microcontroller Unit (MCU) Interface

The MAKO IC has a four-wire, SPI connection to the dual-core processor (SPI B). The SPI B clock is connected to the SPI_CLK pin E6. The SPI B MOSI line is connected to the SPI_DI pin B6. The SPI B MISO line is connected to the SPI_DO pin C6. The MAKO SPI B chip-select signal is connected to the SPI_CS pin D6. Through this interface, the dual-core processor can program the voltage regulators, the CODEC, the transmit and receive audio filters and amplifiers, digital support multiplexing, and read information from the ADC.

The MAKO IC has a 10-bit ADC with eight general-purpose channels and two voltage-monitoring channels. Five out of the eight general-purpose channels are assigned to the display backlight button on the control head (ATOD_2), the monitor volume (ATOD_1), the two-position toggle switch (ATOD_3), the OPT_SEL_IN (ATOD_8), and board type ID (ATOD_5). The other three general purpose channels are unused. Battery voltage is also monitored by the ADC. The dual-core processor reads the ADC values through the SPI bus.

4.3.6.2.1.3 Audio Circuitry

A16-bit CODEC is integrated into the MAKO IC and programmable by the dual-core processor through the SPI bus. The CODEC converts microphone audio data into a digital bit stream for processor by the DSP and converts receive audio data that was processed by the DSP into an analog audio signal for amplification to a speaker. The CODEC interfaces to the DSP through the 4-wire SAP bus. The CODEC clock, which is 512kHz, is generated by the MAKO IC and supplied on the VC_DCLK pin (R772). The CODEC 8 kHz frame synchronization signal is generated by the MAKO IC and supplied on the VC_FSYNC pin (R773). The CODEC transmit data signal is on the VC_TX3V pin and the CODEC receive data signal is on the VC_RX pin. For the MAKO IC to generate the clock and frame sync signals, a 24.576 MHz crystal Y702 is supplied to the XOUT and XIN pins.

The MAKO IC contains internal amplification (digital and analog), filtering, and multiplexing functionality for both receive and transmit audio. These functions are programmable by the dual core processor through the SPI bus. The input for the internal microphone audio (C755) is the INT_MIC_P pin, while the input for the external microphone audio (C754) is the EXT_MIC_P pin. The differential output for the internal speaker is the INT_SPKR_P pin and INT_SPKR_M pin. The differential output for the external speaker is the EXT_SPKR_P pin (C769) and EXT_SPKR_M pin (C768).

4.3.6.2.2 Regulator

The 5 V regulator is internal to the MAKO IC and uses SW_B+ as its input voltage at pin V08_I (C720). The 5 V supply (L705) is used by the bi-directional voltage translators integrated into the MAKO IC, the MAKO IC protection diodes, and the ESD protection circuitry.

The 1.55 V regulator (programmable through the SPI bus) is integrated into the MAKO IC. This regulator uses VSW2 to source the current. The 1.55 V supply (R718) is used by the dual-core processor U701 for its core voltage and clock amplifier.

4.3.6.2.3 Audio Pre-Amplifier

The audio pre-amplifier is integrated into the MAKO IC. The pre-amplifier's supply voltage and gain are programmable and controlled by the dual-core processor through the SPI bus. The input to the pre-amplifier is routed from the internal gain stages within the MAKO IC. The differential output of the pre-amplifier is the VC_OUT_P pin (R844) and VC_OUT_M pin (R798).

4.3.6.2.4 Audio Power Amplifier

The audio power amplifier, supplied by SW_B+, is integrated into the MAKO IC U701. The audio PA is a programmable BTL type and is controlled by the dual-core processor through the SPI bus. The operational state of the PA, as well as selecting between the internal and external audio path, is controlled by the dual-core processor via the SPI bus.

The differential input to the audio PA comes from a low-pass filter (R844, R798, C764, C765, and C790) at the output of the audio pre-amplifier.

4.3.6.3 Interface Support Section

The interface support section includes the following:

- the MAKO IC (U701)
- the ESD protection circuitry, and
- the universal connector interface circuitry.

4.3.6.3.1 MAKO IC U701

The digital-support functions are performed by the MAKO IC. The MAKO IC is contained in a 176-pin BGA with 0.8mm pitch solder balls. The MAKO IC is supplied with three clocks. It is supplied with a 16.8 MHz clock from the transceiver board. It uses a 32.768 kHz crystal to boot up the dual core processor and for the real-time clock. It also uses a 24.576 MHz crystal to generate the SAP clock and frame synchronization signals.

The MAKO IC includes that one-wire option detect support, watchdog timer, and the radio's universal (accessory) side connector interface. It also monitors the position of the on/off switch in order to control the power-up/power-down sequence.

4.3.6.3.1.1 Side Connector Interface, Logic Level Translation, and Boot Data Path Control

The LH Data bidirectional translation is performed internal to the MAKO IC and 3V logic level is on MAKO pin SB96D_BDO_KF_3V.

4.3.6.3.1.2 USB Transceiver

The USB transceiver is internal to MAKO IC U701, and is capable of transmitting and receiving serial data at a rate of 12 megabits per second. The differential USB data comes from the side connector, through the 33-ohm resistors R837 and R838 and then to the USB1_DP and USB1_DM pins on U701. The data will then go through some interfacing and multiplexing internal to the transceiver for 6-wire USB operation and onto the output pins. The USB receive interface through the transceiver to the dual core processor is as follows: DP routed to USB_VPI, DM routed to URXD1_USB_VMI, and the differentially decoded data is output on URTS1_XRXD pin.

The USB transmitter is enabled when the RS232_USB* and USB_TXENAB signals are both driven low by the dual-core processor. The single-ended data is output from the dual-core processor on the UTXD1_USB_VPO pin and goes to USB1_DAT_TXD on U701. The data is driven out differentially on the USB1_DP and USB1_DM pins, which go to the side connector. The dual-core processor sends the single-ended zero signal from pin USB_VMO to the USB1_SE0 pin on U701.

When a USB cable is attached, pin CTS_CABLE_DET_5V is driven low and goes through level translation in U701 and the output of CTS_CABLE_DET_3V is pulsed low and sent to the dual-core processor. This line controls the USB and RS232 modes so that the data that is on those lines are routed to the USB transceiver when a cable is detected. If a USB cable is not detected, CTS_CABLE_DET_3V is high, the transceiver is put in suspend mode and the DP and DM pins can now handle 5V tolerance for RS232 mode.

4.3.6.3.1.3 One-Wire Support

New options and accessories that attach to the side connector are identified by the dual-core processor using the One-Wire protocol. The One-Wire pin on the side connector serves as the One-Wire data pin. This signal is connected to the ONE_WIRE_OPT pin. This pin is connected to the dual-core processor One-wire bus ONE_WIRE_UP through the MAKO IC, U701, internal isolation switch controlled by the SPI commands sent from the dual-core processor. This isolation is needed to prevent possible contention on the One-Wire bus when a smart battery is attached to the radio.

These new accessories are to ground, designator R666, of the side connector. When this occurs, the ONE_WIRE_OPT is asserted and the dual-core processor detects the change. The dual-core processor then sends a command through the SPI lines to the U701 MAKO IC to connect the side connector One-Wire line to the dual-core processor One-Wire bus. In the case of the USB cable, the dual-core processor reads the One-Wire data from the cable and, upon determining that a USB cable is attached, programs the digital-support IC for USB mode.

4.3.6.3.1.4 Watchdog Timer

The watchdog timer is a 125ms counter that is integrated into the MAKO IC U701 and used during the power down sequence. The MAKO IC will begin the power down sequence when a low-to-high transition occurs on MECH_SW pin (MAKO pin E4). Once this transition occurs, the MAKO IC begins the watchdog timer. Upon expiration, RESETX (MAKO pin C5) is asserted and all of the MAKO regulators are shutdown. The dual-core processor can refresh the watchdog timer so that the software has enough time to complete its tasks before the power is taken away.

4.3.6.3.1.5 32 kHz Oscillator and CMOS Output

There is an internal 32kHz oscillator circuitry to the MAKO IC U301 that is based off of a 32.768 kHz crystal Y701 and additional load capacitors C701 and C702. The output of the 32 kHz oscillator is a logic_vdd voltage (approximately 2.9 volts peak-to-peak), 32kHz +/- 20% square wave on pin GATED_32K_CLK. This 32 kHz signal is routed through an analog switch U302 and sent to the dual-core processor CKIL pin. This signal is only used to boot up the dual-core processor.

After the dual-core processor boots up, the select input (R799) of the analog switch is asserted high allowing for the processor to receive an accurate 32.768 kHz, 2.9 V peak-to-peak square wave. This signal is generated by tapping the output of the 32.768 crystal and buffering the signal with the following components: U713, R745, R746, C743, C792, R742, and R741. The 32.768 kHz clock signal allows for the completion of real-time applications.

4.3.6.3.2 ESD Protection Circuitry

Several components on the VOCON section were added to protect the circuitry from Electrostatic Discharge (ESD). The side connector signal lines are exposed and require ESD protection components. These protection components include:

- 5.6 volt zeners (VR659 and VR662) on the CTS and RTS lines, microphone lines, and the option select lines
- 12 volt zener (VR650) on the internal and external speaker audio lines
- 13 volt zener (VR658) on the OPTB+ line, and
- low capacitance ESD suppressors (VR678, VR651, and VR652) on the USB data lines.

4.3.6.3.3 Universal Connector (Side Connector) Interface Circuitry

An important circuit in the side connector interface is the Option Select 2 line comparator. The op-amp (U601) is used as a comparator for the option select 2 line. The voltage divider network of R658 and R673 determines the comparator threshold. The remaining components on the side connector interface consist of current-limiting serial resistors and noise-suppressing shunt capacitors.

4.3.6.3.3.1 Universal Connector (Side Connector) and Option Selects

The universal connector is located on the side of the radio. It is the external port or interface to the outside, and is used for programming and interfacing to external accessories. The universal connector is connected to the main board via a flex circuit at connector J650.

Most of the signals are extensions of circuits described in other areas of this manual. However, there are two option select pins used to configure special modes: Option Select 1 and Option Select 2. These pins are controlled by accessories connected to the universal connector. Connections to the universal connector and J650 are shown in Figure 4.3-2. and Figure 4.3-3., respectively.

Table 4.3-1 outlines their functions as defined at the universal connector.

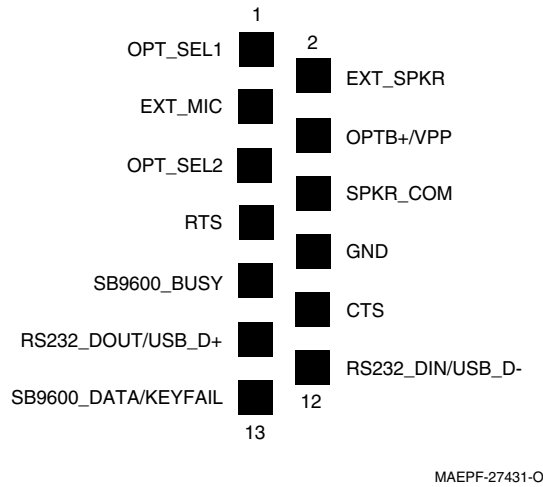

Figure 4.3-2. Universal (Side) Connector

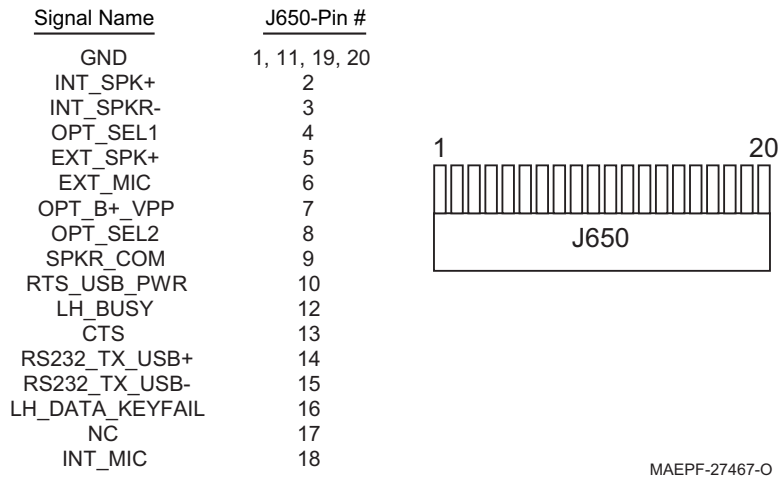

Figure 4.3-3. VOCON Connector J650

Table 4.3-1. Option Select Functions

FUNCTION	Option Select 1	Option Select 2
External PTT	0	0
No Function (Normal)	1	1
Man Down	1	0
External Speaker	0	1

4.3.6.3.4 The Option Board

The Option Board consists of the "keypad module" and the "display module" for models II and III of the XTS 2500/XTS 2500I radio.

4.3.6.3.4.1 Display Module

An optional integral 96 pixels by 64 pixels LCD display module is available with either a 3 x 2 keypad with a navigational button (Model II radios), or 3 x 6 keypad with a navigational button (Model III radios). This unit is not considered field-repairable. The display module is connected to the VOCON section through the flex connector (J900).

The display is controlled by the Patriot's MCU core. The MCU core programs the display through the following:

- EIM data lines D0 - D7 (pins 9 through 16, respectively),
- the display chip select line (pin 5),
- the EIM "write only" line (pin 8), and
- the EIM address 0 line (pin 7).

The EIM address 0 is used to select the register to be programmed. The Patriot may reset the display module through pin 6. The display is supplied with 1.8 volts (C901) to pin 17 and 3 volts (C902) to pin 18.

The Patriot GPIO BL_EN controls the display backlighting; that signal goes to pin 43 of the J601 connector (on the radio board), and the corresponding pin 3 of the J901 connector (on the Option board).

Pin 4 of the J601 connector (on the radio board), and the corresponding pin 42 on the J901 connector (on the Option board) is supplied with 7.5 volts. The 7.5 volts is used to power the LEDs on the display module.

Pin 2 of the J601 connector (on the radio board), and the corresponding pin 44 on the J901 connector (on the Option board), is supplied with the V2 regulated voltage. The V2 regulated voltage is used to power DISPLAY_VCC.

Pin 1 of the J601 connector (on the radio board), and the corresponding pin 45 on the J901 connector (on the Option board), is supplied with 1.8 volts. The 1.8 volts is used to power DISPLAY_VDD.

4.3.6.3.4.2 Keypad Module

The keypad module is connected to the main board through flex connector (J601) on the radio board schematic and J901 on the Option board schematic. The keypad is read through a row-and-column matrix made up of ROW0, ROW1, ROW2, ROW3, ROW4, ROW5, ROW6 and COL0, COL1, and COL2. This totals 18 keys on the keypad. When a key is pressed, a row and a column are connected to one another.

The Patriot determines a key press by a scanning algorithm. Each column line is configured as an open drain output and pulled low. The Patriot then scans the row pins (each row pin has an internal pull up resistor). If a row signal is read low, then the Patriot determines that a key was pressed. If none of the row signal lines are low, then another column line is pulled low and the row scanning routine occurs.

The Patriot GPIO BL_EN controls the keypad backlighting; that signal goes to pin 43 of the J601 connector (on the radio board), and the corresponding pin 3 of the J901 connector (on the Option board). Pin 42 is supplied with 7.5 volts, which is used to power the LEDs on the keypad module.

4.3.6.3.5 Encryption Module

The encryption module (secure models only) connects directly to the VOCON board and interfaces directly with the vocoder digital circuitry. It contains one custom microcontroller IC (Armour) to perform digital, numerical, encryption algorithms.

The encryption modules are designed to digitally encrypt and decrypt voice for ASTRO and NON-ASTRO in XTS 2500/XTS 2500I. This section covers the encryption modules, hardware kits **0104020J49 (Model 1.5), 0104020J50 (Model 2) and 0104020J51 (Model 3)**.

NOTE: The encryption modules are NOT serviceable. The information contained in this section is only intended to help determine whether a problem is due to an encryption module or the radio itself.

The encryption module uses a custom encryption IC and an encryption key variable to perform its encode/decode function. The encryption key variable is loaded into the encryption module, via the radio's universal (side) connector, from a hand-held, key variable loader (KVL). The encryption IC corresponds to the particular encryption algorithm purchased. [Table 4.3-2](#) lists the encryption algorithms and their corresponding kit numbers.

The encryption module operates from two power supplies (UNSW_B+ and SW_B+). The SW_B+ is turned on and off by the radio's On/Off switch. The UNSW_B+ provides power to the encryption module as long as the radio battery is in place.

Key variables are loaded into the encryption module through connector J601, pin 34. Depending on the type of encryption module, up to 16 keys can be stored in the module at a time. The key can be infinite key retention or 30-seconds key retention, depending on how the codeplug is set up.

The radio's host processor communicates with the encryption module on the Synchronous Serial Interface (SSI) bus. The SSI bus consists of four signal lines. A communications failure between the host processor and the secure module will be *ERROR 09/10* or *S03 error* message on the display.

To troubleshoot the encryption module, refer to the flowcharts in [Chapter 6.3 "UHF2 Troubleshooting Charts."](#)

Table 4.3-2. Encryption Module Software Kits and Algorithms

Software Kit Number	Algorithm
Q667AB (7/800), Q667AE (V,U1,U2)	ADP SFWR DSP BASED CRYPTO
Q159AC	XTS 2500/XTS 2500I UCM HARDWARE ENCRYPTION
Q629AD	AES ENCRYPTION
Q625AU	DES, DES-XL, DES-OFB ENCRYPTION
Q668AC	ADP UCM ENCRYPTION W/DES, DES-XL, DES-OFB
H869BQ	MULTI KEY
Q406AC	ADP UCM ENCRYPTION
QA00204AA	MULTIKEY AND ADP
	ADP UCM ENCRYPTION W/AES

4.3.6.3.6 System Clocks

The Patriot is supplied with two clocks:

1. The first clock, a 16.8 MHz sine wave, comes from the RF portion of the radio. It is conditioned by the clock buffer circuit, which includes Q709, R722, R740, R729, R797, C726, C725 and C727.
2. The other clock supplied to Patriot is a 32.768 kHz square wave. This clock is generated by the external 32.768kHz crystal Y701, and a clock buffer circuit that includes U713, R745, R746, C743, C792, R742 and R741. This signal is supplied to the CKIL pin on the dual-core processor.

4.3.6.4 Transmit Audio Path

Refer to [Figure 4.3-4](#). The single-ended internal microphone audio enters the VOCON board through 20 pin side connector (J650), and the internal microphone bias is set by circuitry that includes R751, R753, C751, C753 and C755. The internal microphone signal is connected to the INT_MIC_P pin, which is the input terminal on the MAKO IC internal op-amp G1 after the signal is multiplexed. The gain of the G1 pre-amp is set to +15 dB, which is programmed by dual-core processor SPI lines.

The external microphone audio enters the VOCON board through the remote connector J102, pin10, and the external microphone bias is set by circuitry that includes R750, R752, C750, C752 and C754. The external microphone signal is connected to the EXT_MIC_P pin, which is an input terminal on the MAKO IC internal op-amp G1 after the signal is multiplexed. The gain of the G1 pre-amp is set to +15 dB, which is programmed by dual-core processor SPI lines.

The dual-core processor, through the SPI bus, programs a multiplexer internal to the MAKO IC to select one of the microphone signals. Then, the selected microphone signal goes through the G1 pre-amplifier stage and on to a programmable gain amplifier (G2) before it goes to the CODEC for A/D conversion. The resulting digital data is filtered and sent to the DSP on the CODEC_TX line from the MAKO IC VC_TX3V pin. After additional filtering and processing, the DSP sends the data-out from the STDB pin, labeled TX_SSI_DATA to the RF interface connector.

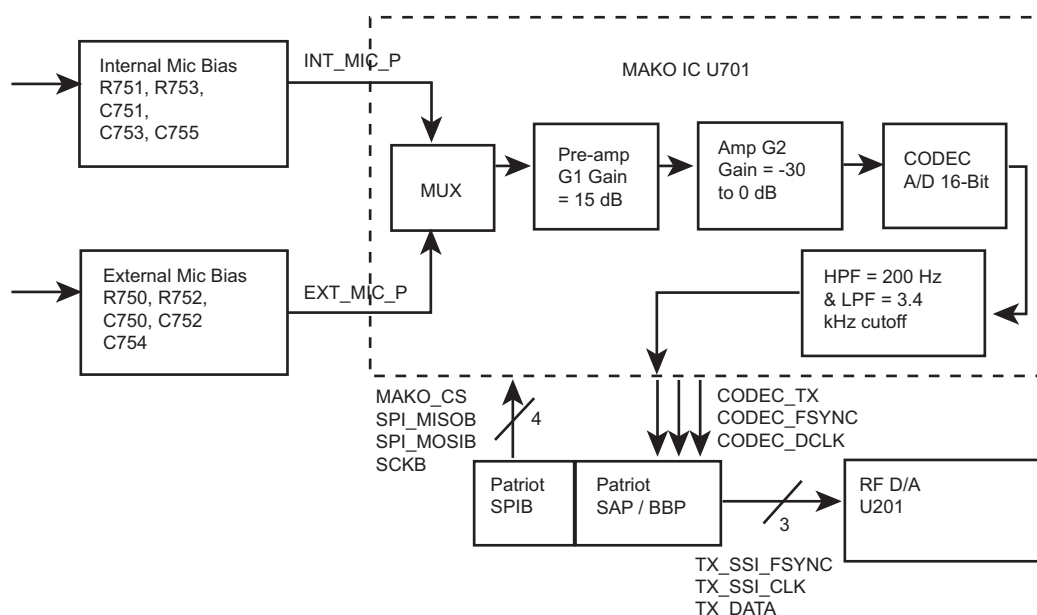

Figure 4.3-4. VOCON Transmit Audio Path

4.3.6.5 Receive Audio Path

Refer to [Figure 4.3-5](#). The receive audio data comes from the Abacus III IC U401 (DOUTA) to the dual-core processor SRDB pin. The DSP decodes the data and sends it out through the CODEC_RX line to the MAKO IC VC_RX3V pin. The CODEC filters, adds digital programmable gain G1, then converts the digital data into an analog audio signal, which in turn is sent to programmable attenuator G3. The signal is then sent through an internal programmable differential preamplifier (G4) to add gain and outputs the signal on pins VC_OUT_P and VC_OUT_M of the MAKO IC.

This output from the preamp is then filtered through circuitry R798, R844, C764, C765, C790, and then sent back to 2 independent internal BTL differential power amplifiers, G5 & G6, of the MAKO IC. The power amplifiers are programmed to a fixed gain of 26 dB through the dual-core processor SPI lines and PA control registers.

The dual-core processor selects whether the amplified audio is routed to the internal speaker or the external speaker through the SPI lines based upon which amplifier is turned on as shown in the PA control block. The output audio is routed on MAKO IC pins INT_SPKR_P and INT_SPKR_M for internal and EXT_SPKR_P and EXT_SPKR_M for external speaker lines.

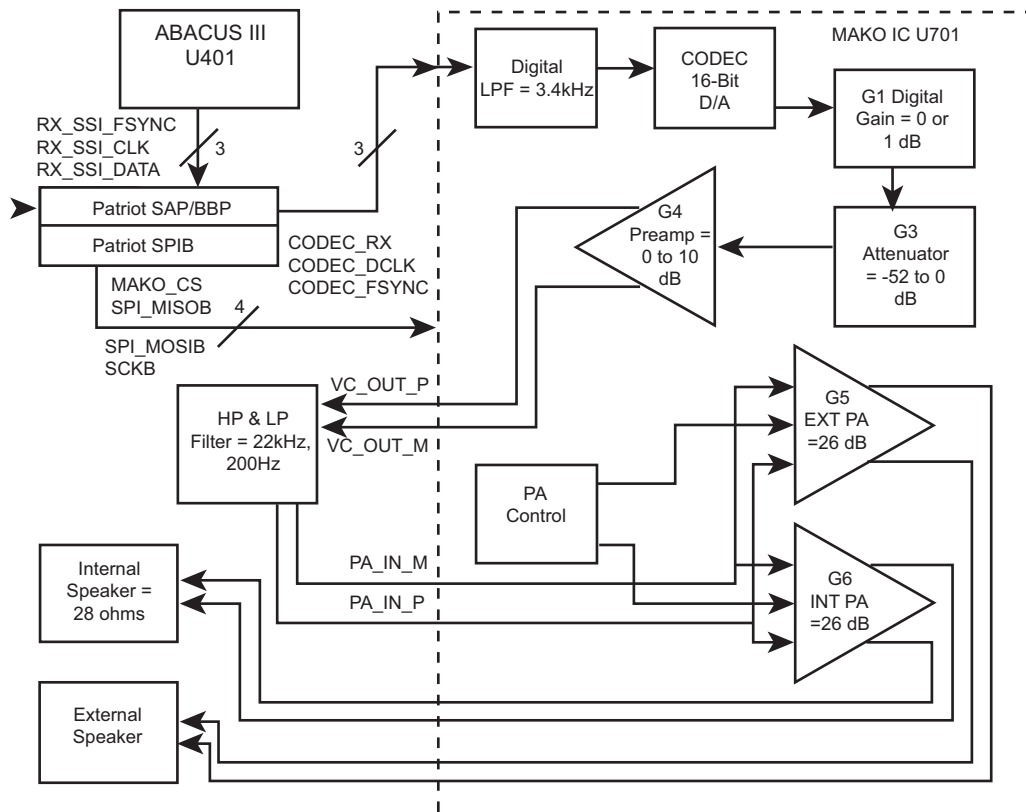

Figure 4.3-5. VOCON Receive Audio Path

Chapter 4.4 700/800 MHz Detailed Theories of Operation

4.4.1 Introduction

This chapter provides a detailed circuit description of the ASTRO XTS 2500/XTS 2500I/XTS 2250/XTS 1500 radio board. When reading the theory of operation, refer to the appropriate schematic and component location diagrams located in the back of this manual. This detailed theory of operation can help isolate the problem to a particular component.

This manual is to be used in conjunction with the ASTRO XTS 2500, XTS 2500I, XTS 2250, XTS 1500, MT 1500 Digital Portable Radios Basic Service Manual (Motorola part number 6816984H01), which uses the pass/fail service approach to radio problems.

4.4.2 Frequency Synthesis

The complete synthesizer subsystem consists of the following:

- The **reference oscillator** (Y200)
- The **voltage-controlled oscillators** (Q210, Q212, and Q214)
- The **voltage-controlled oscillator buffer IC** (U250)
- The **synthesizer** (U201)

The **reference oscillator** contains a temperature-compensated 16.8 MHz crystal. This oscillator is digitally tuned and contains a temperature-referenced, six-bit, analog-to-digital (A/D) converter. The output of the oscillator (pin 3 on Y200) is applied to pin K9 (XTAL1) of U201 through capacitor C243 and resistor R217.

The **voltage-controlled oscillators** (VCOs) are varactor-tuned. The voltage (2V–11V) varies as it is being applied to varactors D210, D211, and D212 of their respective VCO. The capacitance of the varactors also varies, thereby changing the output frequency of the VCOs. The three VCOs are used to cover the entire 700/800MHz band.

- VCO1 covers the RX (downlink) 800MHz band and the talkaround 700MHz (764-776MHz) band.
- VCO2 covers the TX (uplink) 700/800MHz (794-824MHz) band.
- VCO3 covers the talkaround 800MHz (850-870MHz) band and the RX (downlink) 700MHz band.

VCO1, VCO2, and VCO3 are selected using aux1, aux2, and aux4, respectively. TX and RX mode are controlled using aux3: High for RX; Low for TX.

The buffer IC (U250) includes a TX, RX, and prescaler buffer. The main purpose of the prescaler buffer is to individually maintain a constant output and provide isolation. The TX buffer is chosen by setting pin 19 of U250 high; the RX buffer is chosen by setting pin 19 of U250 low. The prescaler buffer is always on. An additional external TX buffer is used with Q217.

The **synthesizer** IC (U201) consists of the following:

- A prescaler
 - A programmable loop divider
 - A divider logic control
 - A phase detector
-

- A charge pump
- An A/D converter for low-frequency digital modulation
- A balance attenuator to balance the high-frequency analog modulation to the low-frequency digital modulation
- A 13V positive voltage multiplier
- A serial interface for control
- A filter for the regulated 5 and 3 volts

The 13V, being generated by the positive voltage multiplier circuitry, should be present at pin A2 of U201. The serial interface (SRL) is connected to the microprocessor via the data line (pin F1 of U201), the clock line (pin F4 of U201), and the chip-enable line (pin G1 of U201).

The complete synthesizer subsystem works as follows:

1. The buffered output of the VCO will be present at pin 8 of U250 in RX mode and pin 10 during the TX mode.
2. The output of the prescaler buffer will be present at pin 12 of U250 and applied to pin 32 of U201. The prescaler in U201 is a dual-modulus type with selectable divider ratios. This divider ratio is controlled by the loop divider, which in turn receives its input from the SRL. The loop divider adds or subtracts phase to the prescaler divider by changing the divider ratio via the modulus control line.
3. The output of the prescaler is then applied to the loop divider.
4. The output of the loop divider then feeds the phase detector. The phase detector will compare the loop divider's output signal from the VCOs. The VCO signal is divided down after it is applied to pin 32 of U201. The result of the comparison is a pulsed DC signal which is applied to the charge pump.
5. The charge pump outputs a current that will be present at pin 43 of U201. The loop filter consisting of C229, C228, C221, C295, C291, C292, C298, R210, R212, and R207, will convert this current into a voltage that will be applied to varactors D210, D211, and D212 to alter the output frequency of the VCO.

In order to modulate the PLL, the following two-port modulation method is utilized: The analog modulating signal is applied to the (1) A/D converter as well as to the (2) balance attenuator:

1. The A/D converter converts the low-frequency analog modulating signal into a digital code. When the digital code is applied to the loop divider, it causes the carrier to deviate.
2. The balance attenuator is used to adjust the VCO's deviation sensitivity to high-frequency modulating signals.

4.4.3 Antenna Switch

An electronic PIN diode switch steers RF between the receiver and transmitter. The common node of the switch is at capacitor C120.

1. In transmit mode:
 - a. RF is routed to the anode of diode CR101.
 - b. Bias current, sourced from U102, pin 32 is routed through PIN diodes CR101 and CR102, biasing them to a low-impedance state.
2. In receive mode:
 - a. RF is routed through pin 1 of FL1.
 - b. PIN diodes CR101 and CR102 are unbiased and thus at high impedance.

4.4.4 Receiver

The receiver consists of the following:

- Front end
- Back end

4.4.4.1 Front End

For the purposes of this discussion, the receiver front end is defined as being the circuitry from the antenna switch to the output of the IF crystal filter. The 700/800 MHz front end converts the received RF signal to the 1st IF frequency of 109.65 MHz, while at the same time providing for spurious immunity and adjacent channel selectivity. A review of the interstage components of the front end follows, with emphasis on troubleshooting considerations.

The received RF signal is passed through **antenna switch** input matching components C101, C116, L109 and C117, tank components C106 and L103 (which are anti-resonant at the radio's transmitter frequencies), and output matching components C103 and L104. Both PIN diodes CR101 and CR102 must be back-biased to properly route the received signal.

The stage following the antenna switch is a 50-ohm, multi-layer ceramic (MLC) varactor-tuned preselector (FL1). The **preselector (FL1)** is positioned after the antenna switch to provide the receiver preamp with some protection against strong signal, out-of-band signals and first-image suppression.

After the preselector (FL1), the received signal is applied to a 15dB step attenuator to provide additional protection against strong signals. The attenuator is controlled by a DSP based algorithm that continuously monitors signal strength. When the ON threshold is exceeded (approximately -95dBm), the attenuator is activated via a DAC in the PCIC by the host. The attenuator remains activated until the signal drops below the OFF threshold (approximately -115dBm including the 15dB attenuation). Hysteresis and timer functions are included in the algorithm to enhance performance. The algorithm controlling the attenuator is enabled via the CPS for each personality. When the algorithm is disabled, the attenuator is essentially a short circuit from input to output. After the attenuator, the received signal is applied to the **receiver preamp, Q1**. The preamp is a transistor, which has been biased and matched for optimum intermodulation (IM), noise figure (NF), and gain performance. Components L1 and C1 match the input (gate 1) of the amp to the first preselector output, while D1 provides some breakdown protection for Q1. The output of the amp's second MLC preselector is matched to C8, L6, and C5. The preamp is supplied by a 3V analog regulator and is biased at approximately 0.75Vdc at the base and 1.7Vdc at the collector. The L1 and C3 network provide improved third order linearity at low.

The output of the amp is matched to a second **three-pole preselector (FL2)** of the type previously discussed. The subsequent stage in the receiver chain is the **1st mixer U1**, which uses low-side injection in the 800 MHz band and high-side injection in the 700 MHz band, to convert the RF carrier to an intermediate frequency (IF) of 109.65 MHz. Since low-side injection is used in the 800 MHz band, the LO frequency is offset below the RF carrier by 109.65 MHz, or $f_{LO} = f_{RF} - 109.65 \text{ MHz}$. The mixer utilizes Bi-CMOS technology in a double-balanced, Gilbert Cell configuration.

A balun transformer (T1) is used to couple the RF signal into the mixer. The primary winding of T1 is matched to the preceding stage by capacitor C35 and inductor L7. The secondary winding of T1 provides a differential output. The center tap pin is grounded via a 39-ohm resistor that sets the mixer bias current. The differential signal is applied directly to the mixer.

The final stage in the receiver front end is a **three-pole crystal filter (FL3)**. The crystal filter provides some of the receiver's adjacent channel selectivity. The input to the crystal filter is matched to the 1st mixer using components L10, C29, L11, C17, L12, and C18. The output of the crystal filter is matched to the input with components C19, L13, C20, and L14. The crystal filter provides at least 80dB of second image protection and improves IM distortion in the ABACUS III IC.

4.4.4.2 Back End

In the **ABACUS IC (U401)**, the first IF frequency is amplified and then down-converted to the second IF frequency (2.25 MHz). At this point, the analog signal is converted into two digital bit streams by a sigma-delta A/D converter. The bit streams are then digitally filtered, mixed down to baseband, and filtered again. The output data stream is then sent to the Patriot IC, where it is decoded to produce the recovered audio.

The ABACUS IC (U401) is electronically programmable. The amount of filtering, which is dependent on the radio channel spacing and signal type, is controlled by the microcomputer. Additional filtering, which used to be provided externally by a conventional ceramic filter, is replaced by internal digital filters in the ABACUS IC.

The ABACUS IC contains a feedback Automatic Gain Control (AGC) circuit to expand the dynamic range of the sigma-delta converter. The differential output data contains the quadrature (I and Q) information in 16-bit words, the AGC information in a 9-bit word, imbedded word sync information, and fill bits. Two synthesizers are available on the chip for second LO and sampling clock (18 MHz) generation.

The second LO/VCO is a Colpitts oscillator built around transistor Q401. A varactor diode (D401) in the VCO is used to adjust the VCO frequency. The control signal for the varactor is derived from a loop filter consisting of C409, R405, C416, R403, and C415. The sampling clock is derived from a negative resistance generator (on the chip) available at CLKP, CLKN, and an external tank circuit (L405, C443, and D402). The loop filter for the clock is realized by C444, R411, and C450.

4.4.5 Transmitter

The 7/800MHz RF power amplifier (PA) consists of:

1. RF driver (**U101**)
2. Silicon N-Channel MOSFET Power Amplifier (**Q101**)

For 7/800MHz band, an RF input drive level of approximately +3dBm is supplied from the VCO buffer IC (**U250**). This input drive level is applied to pin 16 (RFIN) of **U101**. The DC power is applied to pins 6, 7, and 14 of **U101** and to the drain of **Q101** via a filtered RAW_B+. Power control is achieved through the varying of the dc bias (and thus the gain) to pin 1 of **U101** and the gate of **Q101**. The amplified RF signal leaves the RF final PA (**Q101**) at the drain and is applied to the directional coupler (**U106**) via an impedance match. The RF signal passes through the coupler, a discrete antenna switch, and a discrete harmonic filter before finally reaching the antenna launch connector.

A portion of the forward RF power is sampled by the directional coupler (**U106**), applied to the diode (**D103**) for rectification, and the resulting DC signal is fed back to pin 1 of the Power Control IC (**PCIC, U102**). This DC signal is representative of the forward RF power being passed through the directional coupler **U106**). The DC signal is used by the PCIC to regulate the transmitted RF power level.

The PCIC is the heart of the power control loop. The rectified feedback is internally compared to an internal Digital-to-Analog Converter (DAC) output voltage in the PCIC to determine the amount of DC bias voltage at pin 4. This voltage at pin 4 of the PCIC controls the gain (and thus the output power, as explained above) of the RF driver (**U101**) and the N-Channel MOSFET final (**Q101**) via a fixed resistor divider network.

U102 senses the temperature of the printed circuit board (PCB) near the N-Channel MOSFET final (**Q101**) and provides a DC level representative of this temperature to pin 30 of the PCIC. The PCIC uses this input to cut back the output power level after a certain temperature threshold is reached. This ensures:

1. Radio integrity while transmitting in extreme ambient conditions hotter than the radio's operating temperature range.
2. Acts as a safety feature to prevent any thermal runaway fault conditions.

Pin 32 of the PCIC powers the Temperature Sense IC (**U102**) and forward biases the antenna switch diodes (**CR101** and **CR102**) while the radio is in transmit mode. This routes the RF signal from the transmitter to the antenna, as explained above. The antenna switch diodes are unbiased during receive and standby modes; therefore, any RF signal present at the antenna is applied to the receiver.

4.4.6 VOCON Functional Blocks

The three main functional blocks of the VOCON section consist of the following sections:

- the Controller and Memory Section, consisting of the following components:
 - the Patriot IC (U800)
 - the dual-core processor with the microcontroller unit (MCU) and a digital signal processor (DSP)
 - the SRAM IC (U804) and FLASH IC (U803) memory devices.
- the Audio and Power Section and digital support are all embedded into the MAKO IC (U701).
- the Interface Support Section, consisting of the following components:
 - the ESD protection circuitry
 - the side connector interface circuitry, and
 - the Option board.

4.4.6.1 Controller and Memory Section

Three main ICs are in the controller and memory section of the main board schematic: the Patriot IC (U800), the static RAM (SRAM) (U804), and the Flash memory (U803).

4.4.6.1.1 Patriot IC (U800)

The Patriot IC (U800) is a dual-core processor containing both a 32-bit microcontroller unit (MCU) and a 16-bit digital signal processor (DSP) in one IC package. It comes in a 256 pin, ball grid array (BGA) package with 1mm pitch solder balls. The Patriot is supplied with two voltages: 1.875 volts (E801) and 2.9 volts (E800). The 1.875-volt supply is used as the core voltage as well as the interface to the memory devices and display. Most of the pins on the Patriot operate from the 2.9-volt supply.

There are two main clocks that are provided to the Patriot:

1. The CKIH pin is provided by a 16.8MHz sine wave; this is the most important clock since it is internally used to generate the clocks for both the MCU and DSP cores, as well as most of the peripherals.
2. A 2.9-volt peak-to-peak 32.768kHz square wave is supplied to the MCU and DSP cores. It is generated by an external 32.768kHz crystal (Y701), and a clock buffer circuit that includes U712, U713, U714, C742, C743, C791, C792, R745, R747, R748, R799, R741 and R742. This signal is supplied to the CKIL pin on the dual-core processor. While not as widely used as the 16.8MHz clock, the 32.768kHz clock is needed by some components in the dual-core processor, including the reset circuitry.

4.4.6.1.1.1 Microcontroller Unit (MCU)

The MCU portion of the Patriot has 22.5Kx32 bits of internal RAM and 1Kx32 bits of internal ROM. The internal ROM is used for the bootstrapping code. The MCU has several peripherals, including the following:

- an External Interface Module (EIM)
- the Multiple Queue Serial Peripheral Interface (MQSPI)
- two Universal Asynchronous Receiver/Transmitter (UART) modules, and
- the One-Wire Interface module.

The MCU communicates internally to the DSP through the MCU/DSP Interface (MDI).

External Interface Module (EIM)

The External Interface Module (EIM) is the MCU's interface to the SRAM (U804), Flash Memory (U803), and the display. The EIM lines include the following:

- 24 external address lines
- 16 external bi-directional data lines
- 6 chip selects lines
- read/write line, and
- output enable line, among others.

All of the EIM lines operate at 1.8-volt logic levels; the EIM operates at the MCU clock speed.

Multiple Queue Serial Peripheral Interface (MQSPI)

The Multiple Queue Serial Peripheral Interface (MQSPI) is the MCU's programming interface to other ICs. The Patriot has two independent SPI busses, and each has its own clock line, data-out line (MOSI), and data-in line (MISO). There are 10 SPI chip selects (SPICS) that are programmable to either SPI A, the RF board's SPI bus, or to SPI B, the dedicated VOCON SPI bus. The devices on the SPI A bus include the following:

- the PCIC and FRACN IC on the SPICS4, and
- the ABACUS III on SPICS5.

There is one SPI B chip select used for the MAKO IC U701 on SPICS2 (TP_MAKO_CE). All of the lines of the SPI module operate at the GPIO voltage logic level (see section 4.4.6.1.1.).

There are several devices on the RF board that only have one bi-directional SPI data line. Components U801, U802, and Q801 are configured by the MCU GPIO pin TOUT13 (MISOA_SEL) to route the data line to the appropriate pin on the Patriot depending on which SPI device is being accessed.

Universal Asynchronous Receiver/Transmitter (UART)

The Patriot has two Universal Asynchronous Receiver/Transmitter (UART) modules. UART1 (primary UART) handles the RS 232 lines while UART 2 is not used. The primary UART has the following lines:

- a receive data line URXD
- a transmit data line UTXD, and
- hardware flow control signals RTS (request to send) and CTS (clear to send).

All UART lines are operating at the GPIO voltage logic level (see section 4.4.6.1.1.).

One-Wire Interface

The MCU has a One-Wire Interface module that is used to communicate to a One-Wire device like a USB cable or a smart battery using the Dallas Semiconductor protocol. This module has one external pin, OWIRE_DAT (U800 pin F6), and it uses the GPIO voltage logic level.

4.4.6.1.1.2 Digital Signal Processor (DSP)

The DSP portion of the Patriot has 84Kx24 bits of program RAM and 62Kx16 bits of data RAM. The DSP has its own set of peripherals including the following:

- the Baseband Interface Port (BBP)
- the DSP Timer module, and
- the Serial Audio Codec Port (SAP).

Additionally, the DSP shares some peripherals with the MCU, including the USB interface and the General Purpose Input/Output module (GPIO).

Baseband Interface Port (BBP)

The Baseband Interface Port (BBP) module is the DSP's serial synchronous interface (SSI) to the RF board. The BBP has independent sections for the receiver and the transmitter. The receiver BBP pins include

- the receive data pin SRDB
- the receive clock signal pin SC0B, and
- the receive frame synchronization (sync) signal pin SC1B.

The transmitter's BBP pins include

- the transmit data pin STDB (R816)
- the transmit clock signal pin SCKB (TCLK test point), and
- the transmit frame sync signal pin SC2B (TSYNC).

All BBP lines use the GPIO voltage level (see section 4.4.6.1.1.).

DSP Timer Module

While the BBP receive clock and frame sync signals are supplied by the ABACUS III from the RF board, the BBP transmit clock and frame sync signals are generated by the MAKO IC using the 16.8MHz clock (connected to the TCXO_IN M1 pin). The BBP transmit clock and frame sync signals, along with the BBP transmit data signal, are connected to the Digital-to-Analog Converter (DAC) on the RF board.

Serial Audio Codec Port (SAP)

The Serial Audio Codec Port (SAP) module is the DSP's serial synchronous interface (SSI) to the audio codec on the MAKO IC. The SAP interface consist of four signals:

- the SAP clock line pin SCKA (CODEC_DCLK, R772)
- the SAP frame sync line pin SC2A (CODEC_FSYNC, R773)
- the SAP receive data line pin SRDA (CODEC_TX, R774), and
- the transmit data line pin STDA (CODEC_RX, R775).

The SAP clock is generated by the MAKO IC, U701, and it is a 512kHz, 2.9-volt peak-to-peak wave. The SAP frame sync signal is also generated by the MAKO IC, U701 and it is an 8 kHz, 2.9-volt peak-to-peak square wave.

Universal Serial Bus (USB)

The Patriot's USB peripheral, shared by the MCU and the DSP, provides the required buffering and protocol to communicate on the Universal Serial Bus. The Patriot supports USB slave functionality.

- For receive data: the receive data is routed from the MAKO IC (U701) integrated USB transceiver. Single ended positive data is generated at U701 pin B9 and is sent to the dual-core processor pin URXD_RTS. USB data minus comes from U701 pin C9 and is sent to URXD1 of the dual-core processor.
- For transmit data: the USB data comes out of the Patriot UTXD1 pin and goes to the MAKO IC pin C8.

General Purpose Input/Output Module (GPIO)

The GPIO (General Purpose Input/Output) Module is shared by the MCU and the DSP. This module consists of four 16-pin bi-directional ports and a 15 pin bi-directional port. While some of these pins on these ports are being used for other functions (UART, SPI, SAP, BBP, and Interrupt pins), the remaining pins on those ports may be programmed to become GPIOs that may be used by either the DSP or the MCU. Each GPIO pin has up to 8 alternate output functions and up to 4 alternate input functions. This allows for the GPIO pins to be routed internally to pertinent Patriot modules. Additionally, the GPIO module adds selectable edge-triggered or level-sensitive interrupt functionality to the GPIO pins. An example of GPIO pins include the following:

- the LED control signals (RED_LED and GREEN_LED).

4.4.6.1.2 SRAM (U804)

The static RAM (SRAM) is an asynchronous, 1 MB CMOS device that is capable of 70 ns access speed. It is supplied with 1.8 volts. The SRAM has 19 address lines and 16 data lines connected to the External Interface Module (EIM) of the Patriot IC through the ADDR(23:0) and DATA(15:0) busses.

The SRAM has an active low chip-select EN_CE that is connected to the EIM CS2_N pin. When the SRAM EN_CE pin is not asserted, the SRAM is in standby mode, which reduces current consumption.

Two other control signals from the EIM that change the mode of the SRAM are the read/write signal (R/W), and the output enable signal (OE). The R/W of the EIM is connected to the SRAM EN_WE pin while the OE signal from the EIM is connected to the SRAM EN_OE pin. The SRAM is in read mode when the EN_WE pin is not asserted and the EN_OE pin is asserted. The SRAM is in write mode when the EN_WE pin is asserted, regardless of the state of the EN_OE pin.

The other SRAM pins are the lower byte enable pin EN_BLE and the upper byte enable pin EN_BHE. These pins are used to determine which byte (EN_BLE controls data lines 0-7 and EN_BHE controls data lines 8-15) is being used when there is a read or a write request from the Patriot. The EN_BLE pin is controlled by the EIM EB1_N signal while the EN_BHE pin is controlled by the EB0_N signal.

4.4.6.1.3 Flash Memory (U803)

The Flash memory IC is a 8-megabyte CMOS device with simultaneous read/write or simultaneous read/erase operation capabilities with 70 ns access speed. It is supplied with 1.8 volts. The Flash memory has its 22 address lines and 16 data lines connected to the EIM of the Patriot IC through the ADDR(23:0) and DATA(15:0) busses. The Flash memory contains host firmware, DSP firmware, codeplug data, and tuning values.

The RESET_OUT of the Patriot IC (U800) is at the GPIO voltage logic level (see section 4.4.6.1.1.). Components CR800 and R812 are used to convert the voltage down to a 1.8-volt logic level, and this 1.8 volt reset signal is fed to the Flash RESET pin. When this pin is asserted (active low logic), the Flash is in reset mode. In this mode, the internal circuitry powers down and the outputs become high impedance connections.

The Flash active low chip select pin, EN_CE, is connected to the active low CS0 pin (TP_CS0 test point) of the EIM. When the EN_CE is not asserted, the Flash is in standby mode which reduces the current consumption.

Several other active low controls pins determine what mode the Flash memory is in:

- the address valid pin ADV which is connected to the EIM LBA signal
- the output enable pin EN_OE that is connected to the EIM OE signal, and
- the write enable pin EN_WE which connected to the EIM EB1 signal.

For read mode, the ADV and EN_OE pins would be asserted while the EN_WE pin would not be asserted. When the EN_WE is asserted and the EN_OE pin is non-asserted, the Flash would operate in the write mode.

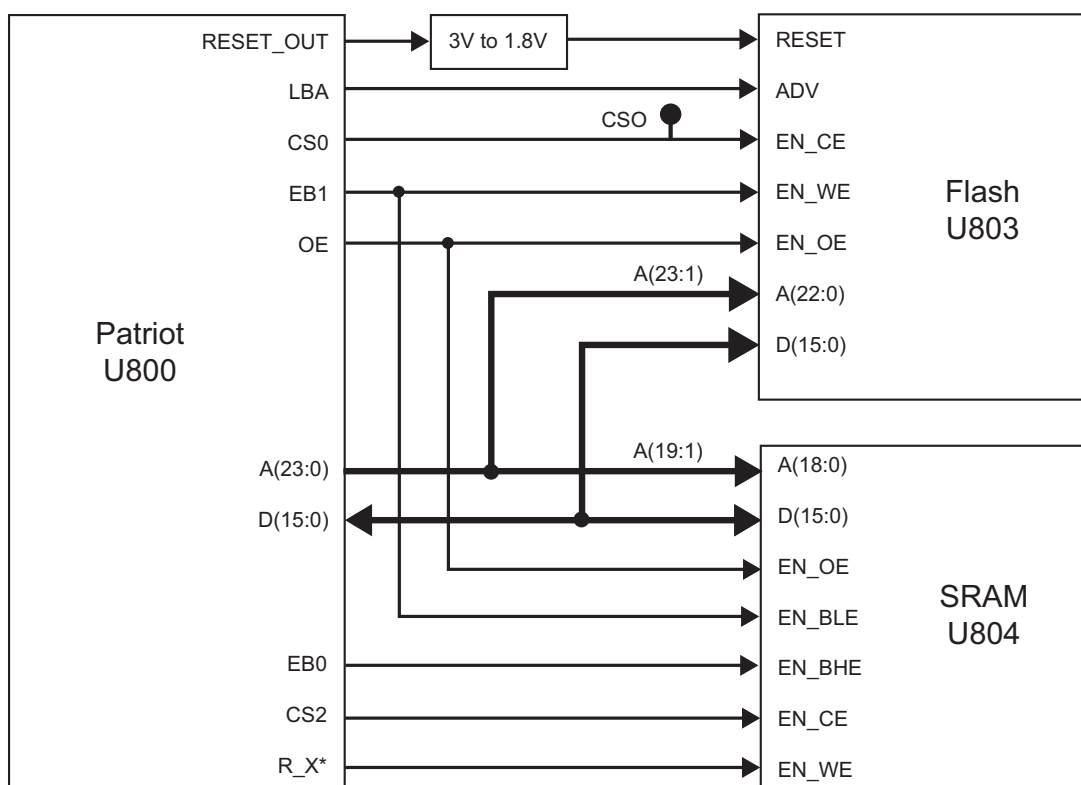

Figure 4.4-1. Controller Memory Interface

4.4.6.2 Audio and Power Section

Two main ICs reside in the audio and power section of the schematic diagram:

- the MAKO IC (U701)
- the VSW1 Driver IC (Q702)

4.4.6.2.1 MAKO IC (U701)

The MAKO IC is a mixed-signal IC that provides control, clock generation, digital support, audio, and voltage regulation functionality. It comes in a 176-pin, ball-grid array (BGA) package with 0.8mm pitch solder balls. The MAKO IC is supplied with switched battery voltage SW_B+.

4.4.6.2.1.1 Voltage Regulation

The MAKO IC contains all of the regulators that are used in the design of the VOCON board:

VSW1, VSW2, V_2.9, V1.55, V1.875, and VCC5. VSW1 is a programmable switching regulator controlled by the MAKO IC on pin SW1_SUMCOMP_DL, while the current is sourced by a driver Q300 using the switched battery voltage (SW_B+). The switching frequency of VSW1 (R711) is programmable by the dual-core processor through the SPI bus. The VSW1 voltage is supplied to the input pin of MAKO's VSW2 regulator (pin SW2_VCCS).

The VSW2 regulator is a SPI programmable switching regulator. The initial and programmed output of VSW2 (C715) is 2.3 volts. The VSW2 voltage is used internal to the MAKO IC to supply the 1.875 volt (V1.875) and 1.55 volt (V1.55) linear voltage regulators. The V1.875 voltage (L703) is supplied to the dual-core processor U800 (EIM voltage), SRAM U804, and Flash memory U803. The V1.55 voltage (R718) is supplied to the dual-core processor U800 (core voltage).

The V_2.9 volt regulator is a linear regulator within the MAKO IC that used VSW1 as its input. The initial output of V_2.9 (L704) is 2.775 volts, which is then programmed to 2.9 volts by the dual-core processor via the SPI bus. The V_2.9 voltage is supplied to the dual-core processor (I/O ring - SPI, BBP, SAP, UART, GPIO, etc.), the display module connector J601, and the many discrete components that interface with the dual-core processor and the MAKO IC.

4.4.6.2.1.2 Microcontroller Unit (MCU) Interface

The MAKO IC has a four-wire, SPI connection to the dual-core processor (SPI B). The SPI B clock is connected to the SPI_CLK pin E6. The SPI B MOSI line is connected to the SPI_DI pin B6. The SPI B MISO line is connected to the SPI_DO pin C6. The MAKO SPI B chip-select signal is connected to the SPI_CS pin D6. Through this interface, the dual-core processor can program the voltage regulators, the CODEC, the transmit and receive audio filters and amplifiers, digital support multiplexing, and read information from the ADC.

The MAKO IC has a 10-bit ADC with eight general-purpose channels and two voltage-monitoring channels. Five out of the eight general-purpose channels are assigned to the display backlight button on the control head (ATOD_2), the monitor volume (ATOD_1), the two-position toggle switch (ATOD_3), the OPT_SEL_IN (ATOD_8), and board type ID (ATOD_5). The other three general purpose channels are unused. Battery voltage is also monitored by the ADC. The dual-core processor reads the ADC values through the SPI bus.

4.4.6.2.1.3 Audio Circuitry

A16-bit CODEC is integrated into the MAKO IC and programmable by the dual-core processor through the SPI bus. The CODEC converts microphone audio data into a digital bit stream for processor by the DSP and converts receive audio data that was processed by the DSP into an analog audio signal for amplification to a speaker. The CODEC interfaces to the DSP through the 4-wire SAP bus. The CODEC clock, which is 512kHz, is generated by the MAKO IC and supplied on the VC_DCLK pin (R772). The CODEC 8 kHz frame synchronization signal is generated by the MAKO IC and supplied on the VC_FSYNC pin (R773). The CODEC transmit data signal is on the VC_TX3V pin and the CODEC receive data signal is on the VC_RX pin. For the MAKO IC to generate the clock and frame sync signals, a 24.576 MHz crystal Y702 is supplied to the XOUT and XIN pins.

The MAKO IC contains internal amplification (digital and analog), filtering, and multiplexing functionality for both receive and transmit audio. These functions are programmable by the dual core processor through the SPI bus. The input for the internal microphone audio (C755) is the INT_MIC_P pin, while the input for the external microphone audio (C754) is the EXT_MIC_P pin. The differential output for the internal speaker is the INT_SPKR_P pin and INT_SPKR_M pin. The differential output for the external speaker is the EXT_SPKR_P pin (C769) and EXT_SPKR_M pin (C768).

4.4.6.2.2 Regulator

The 5 V regulator is internal to the MAKO IC and uses SW_B+ as its input voltage at pin V08_I (C720). The 5 V supply (L705) is used by the bi-directional voltage translators integrated into the MAKO IC, the MAKO IC protection diodes, and the ESD protection circuitry.

The 1.55 V regulator (programmable through the SPI bus) is integrated into the MAKO IC. This regulator uses VSW2 to source the current. The 1.55 V supply (R718) is used by the dual-core processor U701 for its core voltage and clock amplifier.

4.4.6.2.3 Audio Pre-Amplifier

The audio pre-amplifier is integrated into the MAKO IC. The pre-amplifier's supply voltage and gain are programmable and controlled by the dual-core processor through the SPI bus. The input to the pre-amplifier is routed from the internal gain stages within the MAKO IC. The differential output of the pre-amplifier is the VC_OUT_P pin (R844) and VC_OUT_M pin (R798).

4.4.6.2.4 Audio Power Amplifier

The audio power amplifier, supplied by SW_B+, is integrated into the MAKO IC U701. The audio PA is a programmable BTL type and is controlled by the dual-core processor through the SPI bus. The operational state of the PA, as well as selecting between the internal and external audio path, is controlled by the dual-core processor via the SPI bus.

The differential input to the audio PA comes from a low-pass filter (R844, R798, C764, C765, and C790) at the output of the audio pre-amplifier.

4.4.6.3 Interface Support Section

The interface support section includes the following:

- the MAKO IC (U701)
- the ESD protection circuitry, and
- the universal connector interface circuitry.

4.4.6.3.1 MAKO IC U701

The digital-support functions are performed by the MAKO IC. The MAKO IC is contained in a 176-pin BGA with 0.8mm pitch solder balls. The MAKO IC is supplied with three clocks. It is supplied with a 16.8 MHz clock from the transceiver board. It uses a 32.768 kHz crystal to boot up the dual core processor and for the real-time clock. It also uses a 24.576 MHz crystal to generate the SAP clock and frame synchronization signals.

The MAKO IC includes that one-wire option detect support, watchdog timer, and the radio's universal (accessory) side connector interface. It also monitors the position of the on/off switch in order to control the power-up/power-down sequence.

4.4.6.3.1.1 Side Connector Interface, Logic Level Translation, and Boot Data Path Control

The LH Data bidirectional translation is performed internal to the MAKO IC and 3V logic level is on MAKO pin SB96D_BDO_KF_3V.

4.4.6.3.1.2 USB Transceiver

The USB transceiver is internal to MAKO IC U701, and is capable of transmitting and receiving serial data at a rate of 12 megabits per second. The differential USB data comes from the side connector, through the 33-ohm resistors R837 and R838 and then to the USB1_DP and USB1_DM pins on U701. The data will then go through some interfacing and multiplexing internal to the transceiver for 6-wire USB operation and onto the output pins. The USB receive interface through the transceiver to the dual core processor is as follows: DP routed to USB_VPI, DM routed to URXD1_USB_VMI, and the differentially decoded data is output on URTS1_XRXD pin.

The USB transmitter is enabled when the RS232_USB* and USB_TXENAB signals are both driven low by the dual-core processor. The single-ended data is output from the dual-core processor on the UTXD1_USB_VPO pin and goes to USB1_DAT_TXD on U701. The data is driven out differentially on the USB1_DP and USB1_DM pins, which go to the side connector. The dual-core processor sends the single-ended zero signal from pin USB_VMO to the USB1_SE0 pin on U701.

When a USB cable is attached, pin CTS_CABLE_DET_5V is driven low and goes through level translation in U701 and the output of CTS_CABLE_DET_3V is pulsed low and sent to the dual-core processor. This line controls the USB and RS232 modes so that the data that is on those lines are routed to the USB transceiver when a cable is detected. If a USB cable is not detected, CTS_CABLE_DET_3V is high, the transceiver is put in suspend mode and the DP and DM pins can now handle 5V tolerance for RS232 mode.

4.4.6.3.1.3 One-Wire Support

New options and accessories that attach to the side connector are identified by the dual-core processor using the One-Wire protocol. The One-Wire pin on the side connector serves as the One-Wire data pin. This signal is connected to the ONE_WIRE_OPT pin. This pin is connected to the dual-core processor One-wire bus ONE_WIRE_UP through the MAKO IC, U701, internal isolation switch controlled by the SPI commands sent from the dual-core processor. This isolation is needed to prevent possible contention on the One-Wire bus when a smart battery is attached to the radio.

These new accessories are to ground, designator R666, of the side connector. When this occurs, the ONE_WIRE_OPT is asserted and the dual-core processor detects the change. The dual-core processor then sends a command through the SPI lines to the U701 MAKO IC to connect the side connector One-Wire line to the dual-core processor One-Wire bus. In the case of the USB cable, the dual-core processor reads the One-Wire data from the cable and, upon determining that a USB cable is attached, programs the digital-support IC for USB mode.

4.4.6.3.1.4 Watchdog Timer

The watchdog timer is a 125ms counter that is integrated into the MAKO IC U701 and used during the power down sequence. The MAKO IC will begin the power down sequence when a low-to-high transition occurs on MECH_SW pin (MAKO pin E4). Once this transition occurs, the MAKO IC begins the watchdog timer. Upon expiration, RESETX (MAKO pin C5) is asserted and all of the MAKO regulators are shutdown. The dual-core processor can refresh the watchdog timer so that the software has enough time to complete its tasks before the power is taken away.

4.4.6.3.1.5 32 kHz Oscillator and CMOS Output

There is an internal 32kHz oscillator circuitry to the MAKO IC U701 that is based off of a 32.768 kHz crystal Y701 and additional load capacitors C701 and C702. The output of the 32 kHz oscillator is a logic_vdd voltage (approximately 2.9 volts peak-to-peak), 32kHz +/- 20% square wave on pin GATED_32K_CLK. This 32 kHz signal is routed through an analog switch U712 and sent to the dual-core processor CKIL pin. This signal is only used to boot up the dual-core processor.

After the dual-core processor boots up, the select input (R799) of the analog switch is asserted high allowing for the processor to receive an accurate 32.768 kHz, 2.9 V peak-to-peak square wave. This signal is generated by tapping the output of the 32.768 crystal and buffering the signal with the following components: U713, R745, R746, C743, C792, R742, and R741. The 32.768 kHz clock signal allows for the completion of real-time applications.

4.4.6.3.2 ESD Protection Circuitry

Several components on the VOCON section were added to protect the circuitry from Electrostatic Discharge (ESD). The side connector signal lines are exposed and require ESD protection components. These protection components include:

- 5.6 volt zeners (VR659 and VR662) on the CTS and RTS lines, microphone lines, and the option select lines
- 12 volt zener (VR650) on the internal and external speaker audio lines
- 13 volt zener (VR658) on the OPTB+ line, and
- low capacitance ESD suppressors (VR678, VR651, and VR652) on the USB data lines.

4.4.6.3.3 Universal Connector (Side Connector) Interface Circuitry

An important circuit in the side connector interface is the Option Select 2 line comparator. The op-amp (U601) is used as a comparator for the option select 2 line. The voltage divider network of R658 and R673 determines the comparator threshold. The remaining components on the side connector interface consist of current-limiting serial resistors and noise-suppressing shunt capacitors.

4.4.6.3.3.1 Universal Connector (Side Connector) and Option Selects

The universal connector is located on the side of the radio. It is the external port or interface to the outside, and is used for programming and interfacing to external accessories. The universal connector is connected to the main board via a flex circuit at connector J650.

Most of the signals are extensions of circuits described in other areas of this manual. However, there are two option select pins used to configure special modes: Option Select 1 and Option Select 2. These pins are controlled by accessories connected to the universal connector. Connections to the universal connector and J650 are shown in Figure 4.4-2. and Figure 4-3, respectively.

Table 4-1 outlines their functions as defined at the universal connector.

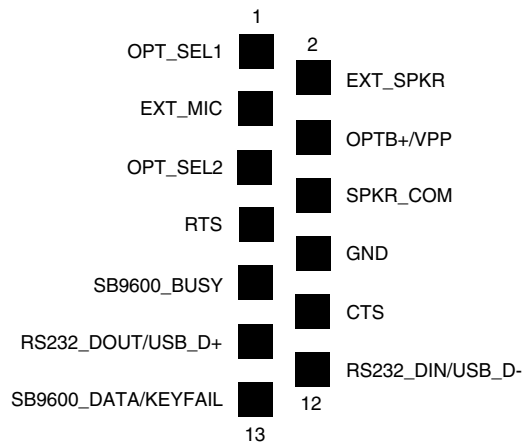

MAEPF-27431-O

Figure 4.4-2. Universal (Side) Connector

Signal Name	J650-Pin #
GND	1, 11, 19, 20
INT_SPK+	2
INT_SPKR-	3
OPT_SEL1	4
EXT_SPK+	5
EXT_MIC	6
OPT_B+_VPP	7
OPT_SEL2	8
SPKR_COM	9
RTS_USB_PWR	10
LH_BUSY	12
CTS	13
RS232_TX_USB+	14
RS232_TX_USB-	15
LH_DATA_KEYFAIL	16
NC	17
INT_MIC	18



MAEPF-27467-O

Figure 4.4-3. VOCON Connector J650

Table 4.4-1. Option Select Functions

FUNCTION	Option Select 1	Option Select 2
External PTT	0	0
No Function (Normal)	1	1
Man Down	1	0

Table 4.4-1. Option Select Functions

FUNCTION	Option Select 1	Option Select 2
External Speaker	0	1

4.4.6.3.4 The Option Board

The Option Board consists of the "keypad module" and the "display module" for models II and III of the XTS 2500/XTS 2500I radio.

4.4.6.3.4.1 Display Module

An optional integral 96 pixels by 64 pixels LCD display module is available with either a 3 x 2 keypad with a navigational button (Model II radios), or 3 x 6 keypad with a navigational button (Model III radios). This unit is not considered field-repairable. The display module is connected to the VOCON section through the flex connector (J900).

The display is controlled by the Patriot's MCU core. The MCU core programs the display through the following:

- EIM data lines D0 - D7 (pins 9 through 16, respectively),
- the display chip select line (pin 5),
- the EIM "write only" line (pin 8), and
- the EIM address 0 line (pin 7).

The EIM address 0 is used to select the register to be programmed. The Patriot may reset the display module through pin 6. The display is supplied with 1.8 volts (C901) to pin 17 and 3 volts (C902) to pin 18.

The Patriot GPIO BL_EN controls the display backlighting; that signal goes to pin 43 of the J601 connector (on the radio board), and the corresponding pin 3 of the J901 connector (on the Option board).

Pin 4 of the J601 connector (on the radio board), and the corresponding pin 42 on the J901 connector (on the Option board) is supplied with 7.5 volts. The 7.5 volts is used to power the LEDs on the display module.

Pin 2 of the J601 connector (on the radio board), and the corresponding pin 44 on the J901 connector (on the Option board), is supplied with the V2 regulated voltage. The V2 regulated voltage is used to power DISPLAY_VCC.

Pin 1 of the J601 connector (on the radio board), and the corresponding pin 45 on the J901 connector (on the Option board), is supplied with 1.8 volts. The 1.8 volts is used to power DISPLAY_VDD.

4.4.6.3.4.2 Keypad Module

The keypad module is connected to the main board through flex connector (J601) on the radio board schematic and J901 on the Option board schematic. The keypad is read through a row-and-column matrix made up of ROW0, ROW1, ROW2, ROW3, ROW4, ROW5, ROW6 and COL0, COL1, and COL2. This totals 18 keys on the keypad. When a key is pressed, a row and a column are connected to one another.

The Patriot determines a key press by a scanning algorithm. Each column line is configured as an open drain output and pulled low. The Patriot then scans the row pins (each row pin has an internal pull up resistor). If a row signal is read low, then the Patriot determines that a key was pressed. If none of the row signal lines are low, then another column line is pulled low and the row scanning routine occurs.

The Patriot GPIO BL_EN controls the keypad backlighting; that signal goes to pin 43 of the J601 connector (on the radio board), and the corresponding pin 3 of the J901 connector (on the Option board). Pin 42 is supplied with 7.5 volts, which is used to power the LEDs on the keypad module.

4.4.6.3.5 Encryption Module

The encryption module (secure models only) connects directly to the VOCON board and interfaces directly with the vocoder digital circuitry. It contains one custom microcontroller IC (Armour) to perform digital, numerical, encryption algorithms.

The encryption modules are designed to digitally encrypt and decrypt voice for ASTRO and NON-ASTRO in XTS 2500/XTS 2500I. This section covers the encryption modules, hardware kits **0104020J49 (Model 1.5)**, **0104020J50 (Model 2)** and **0104020J51 (Model 3)**.

NOTE: The encryption modules are NOT serviceable. The information contained in this section is only intended to help determine whether a problem is due to an encryption module or the radio itself.

The encryption module uses a custom encryption IC and an encryption key variable to perform its encode/decode function. The encryption key variable is loaded into the encryption module, via the radio's universal (side) connector, from a hand-held, key variable loader (KVL). The encryption IC corresponds to the particular encryption algorithm purchased. [Table 4.4-2](#) lists the encryption algorithms and their corresponding kit numbers.

The encryption module operates from two power supplies (UNSW_B+ and SW_B+). The SW_B+ is turned on and off by the radio's On/Off switch. The UNSW_B+ provides power to the encryption module as long as the radio battery is in place.

Key variables are loaded into the encryption module through connector J601, pin 34. Depending on the type of encryption module, up to 16 keys can be stored in the module at a time. The key can be infinite key retention or 30-seconds key retention, depending on how the codeplug is set up.

The radio's host processor communicates with the encryption module on the Synchronous Serial Interface (SSI) bus. The SSI bus consists of four signal lines. A communications failure between the host processor and the secure module will be *ERROR 09/10* or *S03 error* message on the display.

To troubleshoot the encryption module, refer to the flowcharts in [Chapter 6.4 "700/800 MHz Troubleshooting Charts."](#)

Table 4.4-2. Encryption Module Software Kits and Algorithms

Software Kit Number	Algorithm
Q667AB (7/800), Q667AE (V,U1,U2)	ADP SFWR DSP BASED CRYPTO
Q159AC	XTS 2500/XTS 2500I UCM HARDWARE ENCRYPTION
Q629AD	AES ENCRYPTION

Table 4.4-2. Encryption Module Software Kits and Algorithms

Software Kit Number	Algorithm
Q625AU	DES, DES-XL, DES-OFB ENCRYPTION
Q668AC	ADP UCM ENCRYPTION W/DES, DES-XL, DES-OFB
H869BQ	MULTI KEY
Q406AC	ADP UCM ENCRYPTION
QA00204AA	MULTIKEY AND ADP
	ADP UCM ENCRYPTION W/AES

4.4.6.3.6 System Clocks

The Patriot is supplied with two clocks:

1. The first clock, a 16.8 MHz sine wave, comes from the RF portion of the radio. It is conditioned by the clock buffer circuit, which includes Q709, R722, R740, R743, R729, R797, C726, C725 and C727.
2. The other clock supplied to Patriot is a 32.768 kHz square wave. This clock is generated by the external 32.768kHz crystal Y701, and a clock buffer circuit that includes U713, R745, R746, C743, C792, R742 and R741. This signal is supplied to the CKIL pin on the dual-core processor.

4.4.6.4 Transmit Audio Path

Refer to [Figure 4.4-4](#). The single-ended internal microphone audio enters the VOCON board through 20 pin side connector (J650), and the internal microphone bias is set by circuitry that includes R751, R753, C751, C753 and C755. The internal microphone signal is connected to the INT_MIC_P pin, which is the input terminal on the MAKO IC internal op-amp G1 after the signal is multiplexed. The gain of the G1 pre-amp is set to +15 dB, which is programmed by dual-core processor SPI lines.

The external microphone audio enters the VOCON board through the remote connector J102, pin10, and the external microphone bias is set by circuitry that includes R750, R752, C750, C752 and C754. The external microphone signal is connected to the EXT_MIC_P pin, which is an input terminal on the MAKO IC internal op-amp G1 after the signal is multiplexed. The gain of the G1 pre-amp is set to +15 dB, which is programmed by dual-core processor SPI lines.

The dual-core processor, through the SPI bus, programs a multiplexer internal to the MAKO IC to select one of the microphone signals. Then, the selected microphone signal goes through the G1 pre-amplifier stage and on to a programmable gain amplifier (G2) before it goes to the CODEC for A/D conversion. The resulting digital data is filtered and sent to the DSP on the CODEC_TX line from the MAKO IC VC_TX3V pin. After additional filtering and processing, the DSP sends the data-out from the STDB pin, labeled TX_SSI_DATA to the RF interface connector.

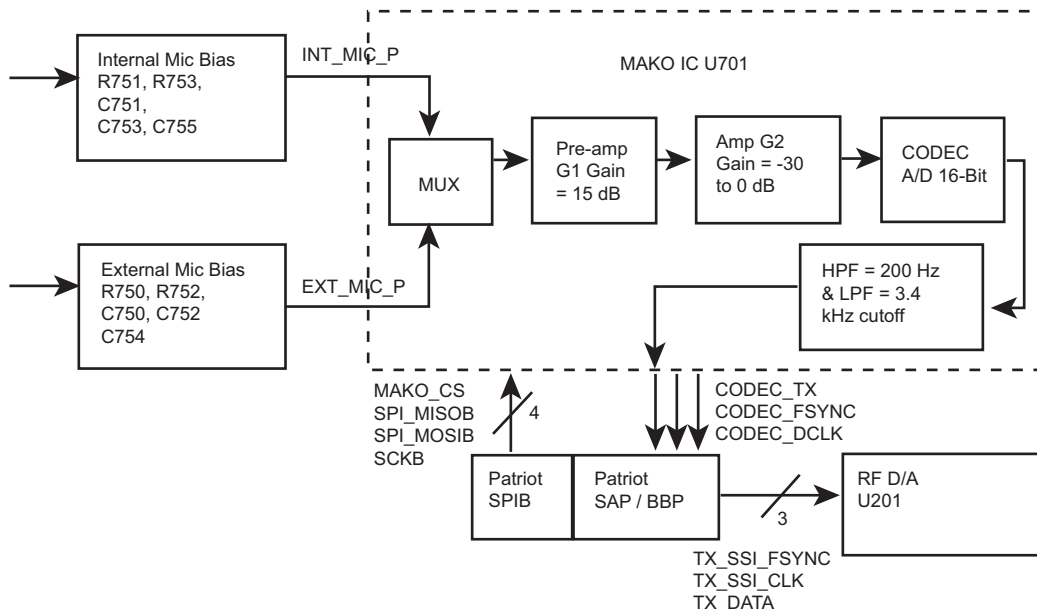

Figure 4.4-4. VOCON Transmit Audio Path

4.4.6.5 Receive Audio Path

Refer to [Figure 4.4-5](#). The receive audio data comes from the Abacus III IC U401 (DOUTA) to the dual-core processor SRDB pin. The DSP decodes the data and sends it out through the CODEC_RX line to the MAKO IC VC_RX3V pin. The CODEC filters, adds digital programmable gain G1, then converts the digital data into an analog audio signal, which in turn is sent to programmable attenuator G3. The signal is then sent through an internal programmable differential preamplifier (G4) to add gain and outputs the signal on pins VC_OUT_P and VC_OUT_M of the MAKO IC.

This output from the preamp is then filtered through circuitry R798, R844, C764, C765, C790, and then sent back to 2 independent internal BTL differential power amplifiers, G5 & G6, of the MAKO IC. The power amplifiers are programmed to a fixed gain of 26 dB through the dual-core processor SPI lines and PA control registers.

The dual-core processor selects whether the amplified audio is routed to the internal speaker or the external speaker through the SPI lines based upon which amplifier is turned on as shown in the PA control block. The output audio is routed on MAKO IC pins INT_SPKR_P and INT_SPKR_M for internal and EXT_SPKR_P and EXT_SPKR_M for external speaker lines.

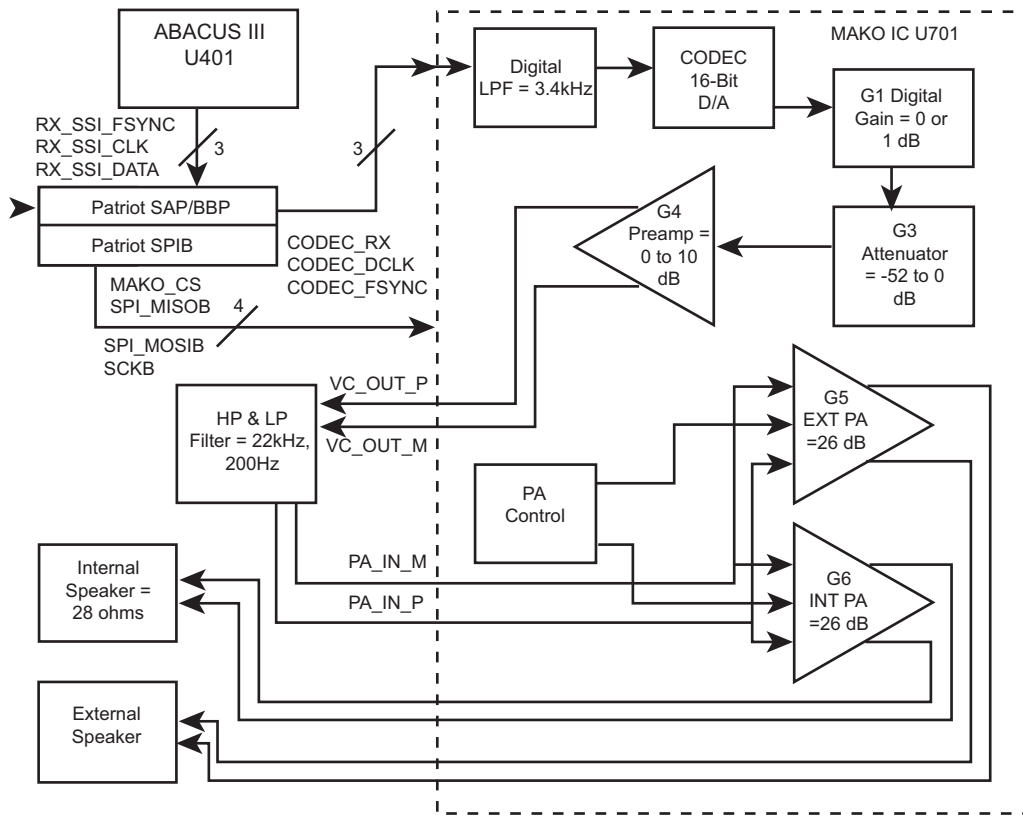

Figure 4.4-5. VOCON Receive Audio Path

Notes

Chapter 4.5 900 MHz Detailed Theories of Operation

4.5.1 Introduction

This chapter provides a detailed circuit description of the ASTRO XTS 2500/XTS 2500I/XTS 2250/XTS 1500 radio board. When reading the theory of operation, refer to the appropriate schematic and component location diagrams located in the back of this manual. This detailed theory of operation can help isolate the problem to a particular component.

This manual is to be used in conjunction with the ASTRO XTS 2500, XTS 2500I, XTS 2250, XTS 1500, MT 1500 Digital Portable Radios Basic Service Manual (Motorola part number 6816984H01), which uses the pass/fail service approach to radio problems.

4.5.2 Frequency Synthesis

The complete synthesizer subsystem consists of the following:

- The **reference oscillator** (Y200)
- The **voltage-controlled oscillators** (Q213 and Q215)
- The **voltage-controlled oscillator buffer IC** (U250)
- The **synthesizer** (U201)

The **reference oscillator** contains a temperature-compensated 16.8 MHz crystal. This oscillator is digitally tuned and contains a temperature-referenced, six-bit, analog-to-digital (A/D) converter. The output of the oscillator (pin 3 on Y200) is applied to pin K9 (XTAL1) of U201 through capacitor C243 and resistor R217.

The **voltage-controlled oscillators** (VCOs) are varactor-tuned. The voltage (2V–11V) varies as it is being applied to varactors D211, and D212 of their respective VCO. The capacitance of the varactors also varies, thereby changing the output frequency of the VCOs. The two VCOs are used to cover the entire 900MHz band.

- VCO1 covers the TX band (896-902MHz and 935-941MHz).
- VCO2 covers the RX 900MHz band (935-941MHz).

VCO1 and VCO2 are selected using aux2, and aux4, respectively. TX and RX mode are controlled using aux3: High for RX; Low for TX.

The buffer IC (U250) includes a TX, RX, and prescaler buffer. The main purpose of the prescaler buffer is to individually maintain a constant output and provide isolation, The TX buffer is chosen by setting pin 19 of U250 high; the RX buffer is chosen by setting pin 19 of U250 low. The prescaler buffer is always on. An additional external TX buffer is used with Q216.

The **synthesizer** IC (U201) consists of the following:

- A prescaler
 - A programmable loop divider
 - A divider logic control
 - A phase detector
 - A charge pump
 - An A/D converter for low-frequency digital modulation
-

- A balance attenuator to balance the high-frequency analog modulation to the low-frequency digital modulation
- A 13V positive voltage multiplier
- A serial interface for control
- A filter for the regulated 5 and 3 volts

The 13V, being generated by the positive voltage multiplier circuitry, should be present at pin A2 of U201. The serial interface (SRL) is connected to the microprocessor via the data line (pin F1 of U201), the clock line (pin F4 of U201), and the chip-enable line (pin G1 of U201).

The complete synthesizer subsystem works as follows:

1. The buffered output of the VCO will be present at pin 8 of U250 in RX mode and pin 10 during the TX mode.
2. The output of the prescaler buffer will be present at pin 12 of U250 and applied to pin 32 of U201. The prescaler in U201 is a dual-modulus type with selectable divider ratios. This divider ratio is controlled by the loop divider, which in turn receives its input from the SRL. The loop divider adds or subtracts phase to the prescaler divider by changing the divider ratio via the modulus control line.
3. The output of the prescaler is then applied to the loop divider.
4. The output of the loop divider then feeds the phase detector. The phase detector will compare the loop divider's output signal from the VCOs. The VCO signal is divided down after it is applied to pin 32 of U201. The result of the comparison is a pulsed DC signal which is applied to the charge pump.
5. The charge pump outputs a current that will be present at pin 43 of U201. The loop filter consisting of C229, C228, C221, C295, C291, C292, C298, R210, R212 and R207, will convert this current into a voltage that will be applied to varactors D211 and D212 to alter the output frequency of the VCO.

In order to modulate the PLL, the following two-port modulation method is utilized: The analog modulating signal is applied to the (1) A/D converter as well as to the (2) balance attenuator:

1. The A/D converter converts the low-frequency analog modulating signal into a digital code. When the digital code is applied to the loop divider, it causes the carrier to deviate.
2. The balance attenuator is used to adjust the VCO's deviation sensitivity to high-frequency modulating signals.

4.5.3 Antenna Switch

An electronic PIN diode switch steers RF between the receiver and transmitter. The common node of the switch is at capacitor C126.

1. In transmit mode:
 - a. RF is routed to the anode of diode CR101.
 - b. Bias current, sourced from U102, pin 32 is routed through PIN diodes CR101 and CR102, biasing them to a low-impedance state.
2. In receive mode:
 - a. RF is routed through pin 1 of FL1.
 - b. PIN diodes CR101 and CR102 are unbiased and thus at high impedance.

4.5.4 Receiver

The receiver consists of the following:

- Front end
- Back end

4.5.4.1 Front End

For the purposes of this discussion, the receiver front end is defined as being the circuitry from the antenna switch to the output of the IF crystal filter. The 900 MHz front end converts the received RF signal to the 1st IF frequency of 109.65 MHz, while at the same time providing for spurious immunity and adjacent channel selectivity. A review of the interstage components of the front end follows, with emphasis on troubleshooting considerations.

The received RF signal is passed through **antenna switch** input matching components, tank components and output matching components. Both PIN diodes CR101 and CR102 must be back-biased to properly route the received signal.

The stage following the antenna switch is a 50-ohm, multi-layer ceramic (MLC) varactor-tuned preselector (FL1). The **preselector (FL1)** is positioned after the antenna switch to provide the receiver preamp with some protection against strong signal, out-of-band signals and first-image suppression.

After the preselector (FL1), the received signal is applied to a 15dB step attenuator to provide additional protection against strong signals. The attenuator is controlled by a DSP based algorithm that continuously monitors signal strength. When the ON threshold is exceeded (approximately -95dBm), the attenuator is activated via a DAC in the PCIC by the host. The attenuator remains activated until the signal drops below the OFF threshold (approximately -115dBm including the 15dB attenuation). Hysteresis and timer functions are included in the algorithm to enhance performance. The algorithm controlling the attenuator is enabled via the CPS for each personality. When the algorithm is disabled, the attenuator is essentially a short circuit from input to output. After the attenuator, the received signal is applied to the **receiver preamp, Q1**. The preamp is a transistor, which has been biased and matched for optimum intermodulation (IM), noise figure (NF), and gain performance. Components L4 and C1 match the input (gate 1) of the amp to the first preselector output, while D800 provides some breakdown protection for Q1. The output of the amp's second MLC preselector is matched to C8, L6, and C5. The preamp is supplied by a 3V analog regulator and is biased at approximately 0.81Vdc at the base and 1.84Vdc at the collector. The L1 and C3 network provide improved third order linearity at low.

The output of the amp is matched to a second **preselector (FL2)** of the type previously discussed. The subsequent stage in the receiver chain is the **1st mixer U1**, which uses low-side injection to convert the RF carrier to an intermediate frequency (IF) of 109.65 MHz. Since low-side injection is used in the 900 MHz band, the LO frequency is offset below the RF carrier by 109.65 MHz, or $F_{LO} = F_{RF} - 109.65 \text{ MHz}$. The mixer utilizes Bi-CMOS technology in a double-balanced, Gilbert Cell configuration.

A balun transformer (T1) is used to couple the RF signal into the mixer. The primary winding of T1 is matched to the preceding stage by coupling capacitor C7. The secondary winding of T1 provides a differential output. The center tap pin is grounded via a 39-ohm resistor that sets the mixer bias current. The differential signal is applied directly to the mixer.

The final stage in the receiver front end is a **three-pole crystal filter (FL3)**. The crystal filter provides some of the receiver's adjacent channel selectivity. The input to the crystal filter is matched to the 1st mixer using components L10, C29, L11, C17, L12, and C18. The output of the crystal filter is matched to the input with components C19, L13, C20, and L14. The crystal filter provides at least 80dB of second image protection and improves IM distortion in the ABACUS III IC.

4.5.4.2 Back End

In the **ABACUS IC (U401)**, the first IF frequency is amplified and then down-converted to the second IF frequency (2.25 MHz). At this point, the analog signal is converted into two digital bit streams by a sigma-delta A/D converter. The bit streams are then digitally filtered, mixed down to baseband, and filtered again. The output data stream is then sent to the Patriot IC, where it is decoded to produce the recovered audio.

The ABACUS IC (U401) is electronically programmable. The amount of filtering, which is dependent on the radio channel spacing and signal type, is controlled by the microcomputer. Additional filtering, which used to be provided externally by a conventional ceramic filter, is replaced by internal digital filters in the ABACUS IC.

The ABACUS IC contains a feedback Automatic Gain Control (AGC) circuit to expand the dynamic range of the sigma-delta converter. The differential output data contains the quadrature (I and Q) information in 16-bit words, the AGC information in a 9-bit word, imbedded word sync information, and fill bits. Two synthesizers are available on the chip for second LO and sampling clock (18 MHz) generation.

The second LO/VCO is a Colpitts oscillator built around transistor Q401. A varactor diode (D401) in the VCO is used to adjust the VCO frequency. The control signal for the varactor is derived from a loop filter consisting of C409, R405, C416, R403, and C415. The sampling clock is derived from a negative resistance generator (on the chip) available at CLKP, CLKN, and an external tank circuit (L405, C443, and D402). The loop filter for the clock is realized by C444, R411, and C450.

4.5.5 Transmitter

The 900MHz RF power amplifier (PA) consists of:

1. RF driver (**U101**)
2. Silicon N-Channel MOSFET Power Amplifier (**Q101**)

For 900MHz band, an RF input drive level of approximately +3dBm is supplied from the VCO buffer IC (**U250**). This input drive level is applied to pin 16 (RFIN) of **U101**. The DC power is applied to pins 6, 7, and 14 of **U101** and to the drain of **Q101** via a filtered RAW_B+. Power control is achieved through the varying of the dc bias (and thus the gain) to pin 1 of **U101** and the gate of **Q101**. The amplified RF signal leaves the RF final PA (**Q101**) at the drain and is applied to the directional coupler (**U106**) via an impedance match. The RF signal passes through the coupler, a discrete antenna switch, and a discrete harmonic filter before finally reaching the antenna launch connector.

A portion of the forward RF power is sampled by the directional coupler (**U106**), applied to the diode (**D103**) for rectification, and the resulting DC signal is fed back to pin 1 of the Power Control IC (**PCIC, U102**). This DC signal is representative of the forward RF power being passed through the directional coupler **U106**). The DC signal is used by the PCIC to regulate the transmitted RF power level.

The PCIC is the heart of the power control loop. The rectified feedback is internally compared to an internal Digital-to-Analog Converter (DAC) output voltage in the PCIC to determine the amount of DC bias voltage at pin 4. This voltage at pin 4 of the PCIC controls the gain (and thus the output power, as explained above) of the RF driver (**U101**) and the N-Channel MOSFET final (**Q101**) via a fixed resistor divider network.

U102 senses the temperature of the printed circuit board (PCB) near the N-Channel MOSFET final (**Q101**) and provides a DC level representative of this temperature to pin 30 of the PCIC. The PCIC uses this input to cut back the output power level after a certain temperature threshold is reached. This ensures:

1. Radio integrity while transmitting in extreme ambient conditions hotter than the radio's operating temperature range.
2. Acts as a safety feature to prevent any thermal runaway fault conditions.

Pin 32 of the PCIC powers the Temperature Sense IC (**U102**) and forward biases the antenna switch diodes (**CR101** and **CR102**) while the radio is in transmit mode. This routes the RF signal from the transmitter to the antenna, as explained above. The antenna switch diodes are unbiased during receive and standby modes; therefore, any RF signal present at the antenna is applied to the receiver.

4.5.6 VOCON Functional Blocks

The three main functional blocks of the VOCON section consist of the following sections:

- the Controller and Memory Section, consisting of the following components:
 - the Patriot IC (U800)
 - the dual-core processor with the microcontroller unit (MCU) and a digital signal processor (DSP)
 - the SRAM IC (U804) and FLASH IC (U803) memory devices.
- the Audio and Power Section and digital support are all embedded into the MAKO IC (U701).
- the Interface Support Section, consisting of the following components:
 - the ESD protection circuitry
 - the side connector interface circuitry, and
 - the Option board.

4.5.6.1 Controller and Memory Section

Three main ICs are in the controller and memory section of the main board schematic: the Patriot IC (U800), the static RAM (SRAM) (U804), and the Flash memory (U803).

4.5.6.1.1 Patriot IC (U800)

The Patriot IC (U800) is a dual-core processor containing both a 32-bit microcontroller unit (MCU) and a 16-bit digital signal processor (DSP) in one IC package. It comes in a 256 pin, ball grid array (BGA) package with 1mm pitch solder balls. The Patriot is supplied with two voltages: 1.875 volts (E801) and 2.9 volts (E800). The 1.875-volt supply is used as the core voltage as well as the interface to the memory devices and display. Most of the pins on the Patriot operate from the 2.9-volt supply.

There are two main clocks that are provided to the Patriot:

1. The CKIH pin is provided by a 16.8MHz sine wave; this is the most important clock since it is internally used to generate the clocks for both the MCU and DSP cores, as well as most of the peripherals.
2. A 2.9-volt peak-to-peak 32.768kHz square wave is supplied to the MCU and DSP cores. It is generated by an external 32.768kHz crystal (Y701), and a clock buffer circuit that includes U712, U713, U714, C742, C743, C791, C792, R745, R747, R748, R799, R741 and R742. This signal is supplied to the CKIL pin on the dual-core processor. While not as widely used as the 16.8MHz clock, the 32.768kHz clock is needed by some components in the dual-core processor, including the reset circuitry.

4.5.6.1.1.1 Microcontroller Unit (MCU)

The MCU portion of the Patriot has 22.5Kx32 bits of internal RAM and 1Kx32 bits of internal ROM. The internal ROM is used for the bootstrapping code. The MCU has several peripherals, including the following:

- an External Interface Module (EIM)
- the Multiple Queue Serial Peripheral Interface (MQSPI)
- two Universal Asynchronous Receiver/Transmitter (UART) modules, and
- the One-Wire Interface module.

The MCU communicates internally to the DSP through the MCU/DSP Interface (MDI).

External Interface Module (EIM)

The External Interface Module (EIM) is the MCU's interface to the SRAM (U804), Flash Memory (U803), and the display. The EIM lines include the following:

- 24 external address lines
- 16 external bi-directional data lines
- 6 chip selects lines
- read/write line, and
- output enable line, among others.

All of the EIM lines operate at 1.8-volt logic levels; the EIM operates at the MCU clock speed.

Multiple Queue Serial Peripheral Interface (MQSPI)

The Multiple Queue Serial Peripheral Interface (MQSPI) is the MCU's programming interface to other ICs. The Patriot has two independent SPI busses, and each has its own clock line, data-out line (MOSI), and data-in line (MISO). There are 10 SPI chip selects (SPICS) that are programmable to either SPI A, the RF board's SPI bus, or to SPI B, the dedicated VOCON SPI bus. The devices on the SPI A bus include the following:

- the PCIC and FRACN IC on the SPICS4, and
- the ABACUS III on SPICS5.

There is one SPI B chip select used for the MAKO IC U701 on SPICS2 (TP_MAKO_CE). All of the lines of the SPI module operate at the GPIO voltage logic level (see section 4.5.6.1.1.).

There are several devices on the RF board that only have one bi-directional SPI data line. Components U801, U802, and Q801 are configured by the MCU GPIO pin TOUT13 (MISOA_SEL) to route the data line to the appropriate pin on the Patriot depending on which SPI device is being accessed.

Universal Asynchronous Receiver/Transmitter (UART)

The Patriot has two Universal Asynchronous Receiver/Transmitter (UART) modules. UART1 (primary UART) handles the RS 232 lines while UART 2 is not used. The primary UART has the following lines:

- a receive data line URXD
- a transmit data line UTXD, and
- hardware flow control signals RTS (request to send) and CTS (clear to send).

All UART lines are operating at the GPIO voltage logic level (see section 4.5.6.1.1.).

One-Wire Interface

The MCU has a One-Wire Interface module that is used to communicate to a One-Wire device like a USB cable or a smart battery using the Dallas Semiconductor protocol. This module has one external pin, OWIRE_DAT (U800 pin F6), and it uses the GPIO voltage logic level.

4.5.6.1.1.2 Digital Signal Processor (DSP)

The DSP portion of the Patriot has 84Kx24 bits of program RAM and 62Kx16 bits of data RAM. The DSP has its own set of peripherals including the following:

- the Baseband Interface Port (BBP)
- the DSP Timer module, and
- the Serial Audio Codec Port (SAP).

Additionally, the DSP shares some peripherals with the MCU, including the USB interface and the General Purpose Input/Output module (GPIO).

Baseband Interface Port (BBP)

The Baseband Interface Port (BBP) module is the DSP's serial synchronous interface (SSI) to the RF board. The BBP has independent sections for the receiver and the transmitter. The receiver BBP pins include

- the receive data pin SRDB
- the receive clock signal pin SC0B, and
- the receive frame synchronization (sync) signal pin SC1B.

The transmitter's BBP pins include

- the transmit data pin STDB (R816)
- the transmit clock signal pin SCKB (TCLK test point), and
- the transmit frame sync signal pin SC2B (TSYNC).

All BBP lines use the GPIO voltage level (see section 4.5.6.1.1.).

DSP Timer Module

While the BBP receive clock and frame sync signals are supplied by the ABACUS III from the RF board, the BBP transmit clock and frame sync signals are generated by the MAKO IC using the 16.8MHz clock (connected to the TCXO_IN M1 pin). The BBP transmit clock and frame sync signals, along with the BBP transmit data signal, are connected to the Digital-to-Analog Converter (DAC) on the RF board.

Serial Audio Codec Port (SAP)

The Serial Audio Codec Port (SAP) module is the DSP's serial synchronous interface (SSI) to the audio codec on the MAKO IC. The SAP interface consist of four signals:

- the SAP clock line pin SCKA (CODEC_DCLK, R772)
- the SAP frame sync line pin SC2A (CODEC_FSYNC, R773)
- the SAP receive data line pin SRDA (CODEC_TX, R774), and
- the transmit data line pin STDA (CODEC_RX, R775).

The SAP clock is generated by the MAKO IC, U701, and it is a 512kHz, 2.9-volt peak-to-peak wave. The SAP frame sync signal is also generated by the MAKO IC, U701 and it is an 8 kHz, 2.9-volt peak-to-peak square wave.

Universal Serial Bus (USB)

The Patriot's USB peripheral, shared by the MCU and the DSP, provides the required buffering and protocol to communicate on the Universal Serial Bus. The Patriot supports USB slave functionality.

- For receive data: the receive data is routed from the MAKO IC (U701) integrated USB transceiver. Single ended positive data is generated at U701 pin B9 and is sent to the dual-core processor pin URXD_RTS. USB data minus comes from U701 pin C9 and is sent to URXD1 of the dual-core processor.
- For transmit data: the USB data comes out of the Patriot UTXD1 pin and goes to the MAKO IC pin C8.

General Purpose Input/Output Module (GPIO)

The GPIO (General Purpose Input/Output) Module is shared by the MCU and the DSP. This module consists of four 16-pin bi-directional ports and a 15 pin bi-directional port. While some of these pins on these ports are being used for other functions (UART, SPI, SAP, BBP, and Interrupt pins), the remaining pins on those ports may be programmed to become GPIOs that may be used by either the DSP or the MCU. Each GPIO pin has up to 8 alternate output functions and up to 4 alternate input functions. This allows for the GPIO pins to be routed internally to pertinent Patriot modules. Additionally, the GPIO module adds selectable edge-triggered or level-sensitive interrupt functionality to the GPIO pins. An example of GPIO pins include the following:

- the LED control signals (RED_LED and GREEN_LED).

4.5.6.1.2 SRAM (U804)

The static RAM (SRAM) is an asynchronous, 1 MB CMOS device that is capable of 70 ns access speed. It is supplied with 1.8 volts. The SRAM has 19 address lines and 16 data lines connected to the External Interface Module (EIM) of the Patriot IC through the ADDR(23:0) and DATA(15:0) busses.

The SRAM has an active low chip-select EN_CE that is connected to the EIM CS2_N pin. When the SRAM EN_CE pin is not asserted, the SRAM is in standby mode, which reduces current consumption.

Two other control signals from the EIM that change the mode of the SRAM are the read/write signal (R/W), and the output enable signal (OE). The R/W of the EIM is connected to the SRAM EN_WE pin while the OE signal from the EIM is connected to the SRAM EN_OE pin. The SRAM is in read mode when the EN_WE pin is not asserted and the EN_OE pin is asserted. The SRAM is in write mode when the EN_WE pin is asserted, regardless of the state of the EN_OE pin.

The other SRAM pins are the lower byte enable pin EN_BLE and the upper byte enable pin EN_BHE. These pins are used to determine which byte (EN_BLE controls data lines 0-7 and EN_BHE controls data lines 8-15) is being used when there is a read or a write request from the Patriot. The EN_BLE pin is controlled by the EIM EB1_N signal while the EN_BHE pin is controlled by the EB0_N signal.

4.5.6.1.3 Flash Memory (U803)

The Flash memory IC is a 8-megabyte CMOS device with simultaneous read/write or simultaneous read/erase operation capabilities with 70 ns access speed. It is supplied with 1.8 volts. The Flash memory has its 22 address lines and 16 data lines connected to the EIM of the Patriot IC through the ADDR(23:0) and DATA(15:0) busses. The Flash memory contains host firmware, DSP firmware, codeplug data, and tuning values.

The RESET_OUT of the Patriot IC (U800) is at the GPIO voltage logic level (see section 4.5.6.1.1.). Components CR800 and R812 are used to convert the voltage down to a 1.8-volt logic level, and this 1.8 volt reset signal is fed to the Flash RESET pin. When this pin is asserted (active low logic), the Flash is in reset mode. In this mode, the internal circuitry powers down and the outputs become high impedance connections.

The Flash active low chip select pin, EN_CE, is connected to the active low CS0 pin (TP_CS0 test point) of the EIM. When the EN_CE is not asserted, the Flash is in standby mode which reduces the current consumption.

Several other active low controls pins determine what mode the Flash memory is in:

- the address valid pin ADV which is connected to the EIM LBA signal
- the output enable pin EN_OE that is connected to the EIM OE signal, and
- the write enable pin EN_WE which connected to the EIM EB1 signal.

For read mode, the ADV and EN_OE pins would be asserted while the EN_WE pin would not be asserted. When the EN_WE is asserted and the EN_OE pin is non-asserted, the Flash would operate in the write mode.

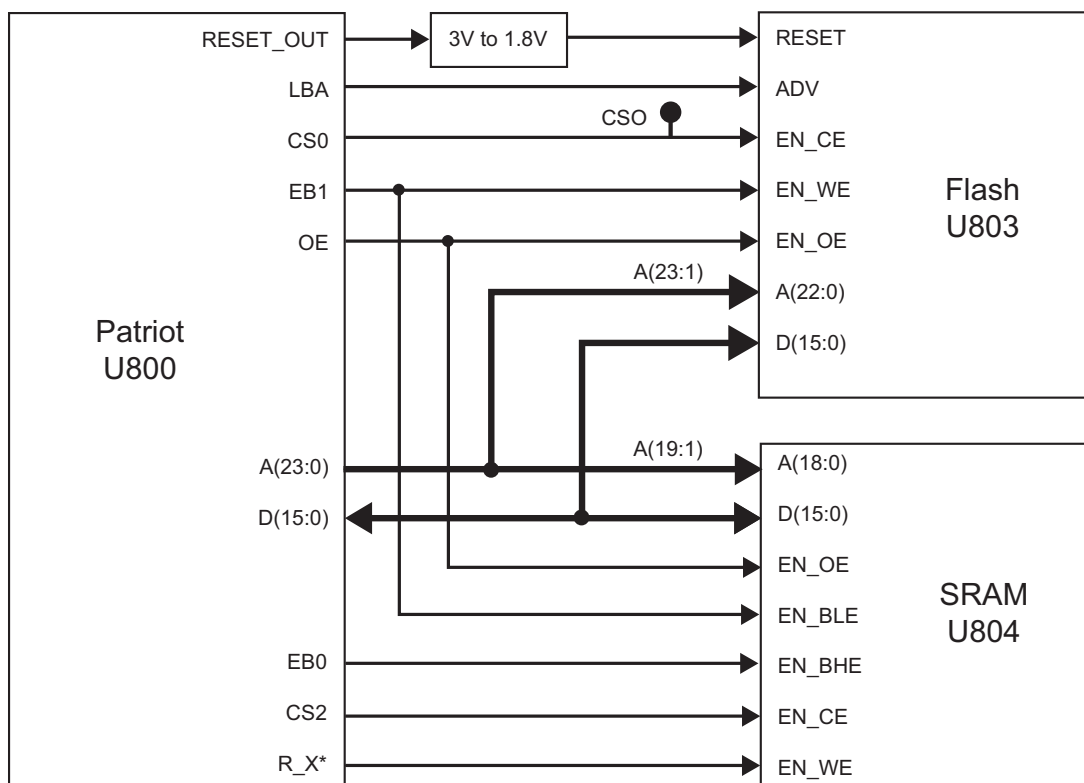

Figure 4.5-1. Controller Memory Interface

4.5.6.2 Audio and Power Section

Two main ICs reside in the audio and power section of the schematic diagram:

- the MAKO IC (U701)
- the VSW1 Driver IC (Q702)

4.5.6.2.1 MAKO IC (U701)

The MAKO IC is a mixed-signal IC that provides control, clock generation, digital support, audio, and voltage regulation functionality. It comes in a 176-pin, ball-grid array (BGA) package with 0.8mm pitch solder balls. The MAKO IC is supplied with switched battery voltage SW_B+.

4.5.6.2.1.1 Voltage Regulation

The MAKO IC contains all of the regulators that are used in the design of the VOCON board:

VSW1, VSW2, V_2.9, V1.55, V1.875, and VCC5. VSW1 is a programmable switching regulator controlled by the MAKO IC on pin SW1_SUMCOMP_DL, while the current is sourced by a driver Q300 using the switched battery voltage (SW_B+). The switching frequency of VSW1 (R711) is programmable by the dual-core processor through the SPI bus. The VSW1 voltage is supplied to the input pin of MAKO's VSW2 regulator (pin SW2_VCCS).

The VSW2 regulator is a SPI programmable switching regulator. The initial and programmed output of VSW2 (C715) is 2.3 volts. The VSW2 voltage is used internal to the MAKO IC to supply the 1.875 volt (V1.875) and 1.55 volt (V1.55) linear voltage regulators. The V1.875 voltage (L703) is supplied to the dual-core processor U800 (EIM voltage), SRAM U804, and Flash memory U803. The V1.55 voltage (R718) is supplied to the dual-core processor U800 (core voltage).

The V_2.9 volt regulator is a linear regulator within the MAKO IC that used VSW1 as its input. The initial output of V_2.9 (L704) is 2.775 volts, which is then programmed to 2.9 volts by the dual-core processor via the SPI bus. The V_2.9 voltage is supplied to the dual-core processor (I/O ring - SPI, BBP, SAP, UART, GPIO, etc.), the display module connector J601, and the many discrete components that interface with the dual-core processor and the MAKO IC.

4.5.6.2.1.2 Microcontroller Unit (MCU) Interface

The MAKO IC has a four-wire, SPI connection to the dual-core processor (SPI B). The SPI B clock is connected to the SPI_CLK pin E6. The SPI B MOSI line is connected to the SPI_DI pin B6. The SPI B MISO line is connected to the SPI_DO pin C6. The MAKO SPI B chip-select signal is connected to the SPI_CS pin D6. Through this interface, the dual-core processor can program the voltage regulators, the CODEC, the transmit and receive audio filters and amplifiers, digital support multiplexing, and read information from the ADC.

The MAKO IC has a 10-bit ADC with eight general-purpose channels and two voltage-monitoring channels. Five out of the eight general-purpose channels are assigned to the display backlight button on the control head (ATOD_2), the monitor volume (ATOD_1), the two-position toggle switch (ATOD_3), the OPT_SEL_IN (ATOD_8), and board type ID (ATOD_5). The other three general purpose channels are unused. Battery voltage is also monitored by the ADC. The dual-core processor reads the ADC values through the SPI bus.

4.5.6.2.1.3 Audio Circuitry

A16-bit CODEC is integrated into the MAKO IC and programmable by the dual-core processor through the SPI bus. The CODEC converts microphone audio data into a digital bit stream for processor by the DSP and converts receive audio data that was processed by the DSP into an analog audio signal for amplification to a speaker. The CODEC interfaces to the DSP through the 4-wire SAP bus. The CODEC clock, which is 512kHz, is generated by the MAKO IC and supplied on the VC_DCLK pin (R772). The CODEC 8 kHz frame synchronization signal is generated by the MAKO IC and supplied on the VC_FSYNC pin (R773). The CODEC transmit data signal is on the VC_TX3V pin and the CODEC receive data signal is on the VC_RX pin. For the MAKO IC to generate the clock and frame sync signals, a 24.576 MHz crystal Y702 is supplied to the XOUT and XIN pins.

The MAKO IC contains internal amplification (digital and analog), filtering, and multiplexing functionality for both receive and transmit audio. These functions are programmable by the dual core processor through the SPI bus. The input for the internal microphone audio (C755) is the INT_MIC_P pin, while the input for the external microphone audio (C754) is the EXT_MIC_P pin. The differential output for the internal speaker is the INT_SPKR_P pin and INT_SPKR_M pin. The differential output for the external speaker is the EXT_SPKR_P pin (C769) and EXT_SPKR_M pin (C768).

4.5.6.2.2 Regulator

The 5 V regulator is internal to the MAKO IC and uses SW_B+ as its input voltage at pin V08_I (C720). The 5 V supply (L705) is used by the bi-directional voltage translators integrated into the MAKO IC, the MAKO IC protection diodes, and the ESD protection circuitry.

The 1.55 V regulator (programmable through the SPI bus) is integrated into the MAKO IC. This regulator uses VSW2 to source the current. The 1.55 V supply (R718) is used by the dual-core processor U701 for its core voltage and clock amplifier.

4.5.6.2.3 Audio Pre-Amplifier

The audio pre-amplifier is integrated into the MAKO IC. The pre-amplifier's supply voltage and gain are programmable and controlled by the dual-core processor through the SPI bus. The input to the pre-amplifier is routed from the internal gain stages within the MAKO IC. The differential output of the pre-amplifier is the VC_OUT_P pin (R844) and VC_OUT_M pin (R798).

4.5.6.2.4 Audio Power Amplifier

The audio power amplifier, supplied by SW_B+, is integrated into the MAKO IC U701. The audio PA is a programmable BTL type and is controlled by the dual-core processor through the SPI bus. The operational state of the PA, as well as selecting between the internal and external audio path, is controlled by the dual-core processor via the SPI bus.

The differential input to the audio PA comes from a low-pass filter (R844, R798, C764, C765, and C790) at the output of the audio pre-amplifier.

4.5.6.3 Interface Support Section

The interface support section includes the following:

- the MAKO IC (U701)
- the ESD protection circuitry, and
- the universal connector interface circuitry.

4.5.6.3.1 MAKO IC U701

The digital-support functions are performed by the MAKO IC. The MAKO IC is contained in a 176-pin BGA with 0.8mm pitch solder balls. The MAKO IC is supplied with three clocks. It is supplied with a 16.8 MHz clock from the transceiver board. It uses a 32.768 kHz crystal to boot up the dual core processor and for the real-time clock. It also uses a 24.576 MHz crystal to generate the SAP clock and frame synchronization signals.

The MAKO IC includes that one-wire option detect support, watchdog timer, and the radio's universal (accessory) side connector interface. It also monitors the position of the on/off switch in order to control the power-up/power-down sequence.

4.5.6.3.1.1 Side Connector Interface, Logic Level Translation, and Boot Data Path Control

The LH Data bidirectional translation is performed internal to the MAKO IC and 3V logic level is on MAKO pin SB96D_BDO_KF_3V.

4.5.6.3.1.2 USB Transceiver

The USB transceiver is internal to MAKO IC U701, and is capable of transmitting and receiving serial data at a rate of 12 megabits per second. The differential USB data comes from the side connector, through the 33-ohm resistors R837 and R838 and then to the USB1_DP and USB1_DM pins on U701. The data will then go through some interfacing and multiplexing internal to the transceiver for 6-wire USB operation and onto the output pins. The USB receive interface through the transceiver to the dual core processor is as follows: DP routed to USB_VPI, DM routed to URXD1_USB_VMI, and the differentially decoded data is output on URTS1_XRXD pin.

The USB transmitter is enabled when the RS232_USB* and USB_TXENAB signals are both driven low by the dual-core processor. The single-ended data is output from the dual-core processor on the UTXD1_USB_VPO pin and goes to USB1_DAT_TXD on U701. The data is driven out differentially on the USB1_DP and USB1_DM pins, which go to the side connector. The dual-core processor sends the single-ended zero signal from pin USB_VMO to the USB1_SE0 pin on U701.

When a USB cable is attached, pin CTS_CABLE_DET_5V is driven low and goes through level translation in U701 and the output of CTS_CABLE_DET_3V is pulsed low and sent to the dual-core processor. This line controls the USB and RS232 modes so that the data that is on those lines are routed to the USB transceiver when a cable is detected. If a USB cable is not detected, CTS_CABLE_DET_3V is high, the transceiver is put in suspend mode and the DP and DM pins can now handle 5V tolerance for RS232 mode.

4.5.6.3.1.3 One-Wire Support

New options and accessories that attach to the side connector are identified by the dual-core processor using the One-Wire protocol. The One-Wire pin on the side connector serves as the One-Wire data pin. This signal is connected to the ONE_WIRE_OPT pin. This pin is connected to the dual-core processor One-wire bus ONE_WIRE_UP through the MAKO IC, U701, internal isolation switch controlled by the SPI commands sent from the dual-core processor. This isolation is needed to prevent possible contention on the One-Wire bus when a smart battery is attached to the radio.

These new accessories are to ground, designator R666, of the side connector. When this occurs, the ONE_WIRE_OPT is asserted and the dual-core processor detects the change. The dual-core processor then sends a command through the SPI lines to the U701 MAKO IC to connect the side connector One-Wire line to the dual-core processor One-Wire bus. In the case of the USB cable, the dual-core processor reads the One-Wire data from the cable and, upon determining that a USB cable is attached, programs the digital-support IC for USB mode.

4.5.6.3.1.4 Watchdog Timer

The watchdog timer is a 125ms counter that is integrated into the MAKO IC U701 and used during the power down sequence. The MAKO IC will begin the power down sequence when a low-to-high transition occurs on MECH_SW pin (MAKO pin E4). Once this transition occurs, the MAKO IC begins the watchdog timer. Upon expiration, RESETX (MAKO pin C5) is asserted and all of the MAKO regulators are shutdown. The dual-core processor can refresh the watchdog timer so that the software has enough time to complete its tasks before the power is taken away.

4.5.6.3.1.5 32 kHz Oscillator and CMOS Output

There is an internal 32kHz oscillator circuitry to the MAKO IC U301 that is based off of a 32.768 kHz crystal Y701 and additional load capacitors C701 and C702. The output of the 32 kHz oscillator is a logic_vdd voltage (approximately 2.9 volts peak-to-peak), 32kHz +/- 20% square wave on pin GATED_32K_CLK. This 32 kHz signal is routed through an analog switch U302 and sent to the dual-core processor CKIL pin. This signal is only used to boot up the dual-core processor.

After the dual-core processor boots up, the select input (R799) of the analog switch is asserted high allowing for the processor to receive an accurate 32.768 kHz, 2.9 V peak-to-peak square wave. This signal is generated by tapping the output of the 32.768 crystal and buffering the signal with the following components: U713, R745, R746, C743, C792, R742, and R741. The 32.768 kHz clock signal allows for the completion of real-time applications.

4.5.6.3.2 ESD Protection Circuitry

Several components on the VOCON section were added to protect the circuitry from Electrostatic Discharge (ESD). The side connector signal lines are exposed and require ESD protection components. These protection components include:

- 5.6 volt zeners (VR659 and VR662) on the CTS and RTS lines, microphone lines, and the option select lines
- 12 volt zener (VR650) on the internal and external speaker audio lines
- 13 volt zener (VR658) on the OPTB+ line, and
- low capacitance ESD suppressors (VR678, VR651, and VR652) on the USB data lines.

4.5.6.3.3 Universal Connector (Side Connector) Interface Circuitry

An important circuit in the side connector interface is the Option Select 2 line comparator. The op-amp (U601) is used as a comparator for the option select 2 line. The voltage divider network of R658 and R673 determines the comparator threshold. The remaining components on the side connector interface consist of current-limiting serial resistors and noise-suppressing shunt capacitors.

4.5.6.3.3.1 Universal Connector (Side Connector) and Option Selects

The universal connector is located on the side of the radio. It is the external port or interface to the outside, and is used for programming and interfacing to external accessories. The universal connector is connected to the main board via a flex circuit at connector J650.

Most of the signals are extensions of circuits described in other areas of this manual. However, there are two option select pins used to configure special modes: Option Select 1 and Option Select 2. These pins are controlled by accessories connected to the universal connector. Connections to the universal connector and J650 are shown in Figure 4.5-2. and Figure 4.5-3., respectively.

[Table 4.5-1](#) outlines their functions as defined at the universal connector.

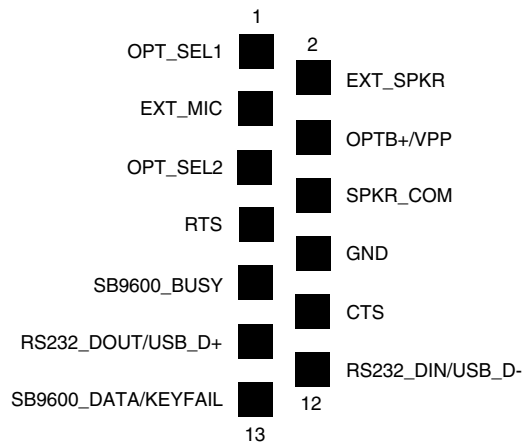

MAEPF-27431-O

Figure 4.5-2. Universal (Side) Connector

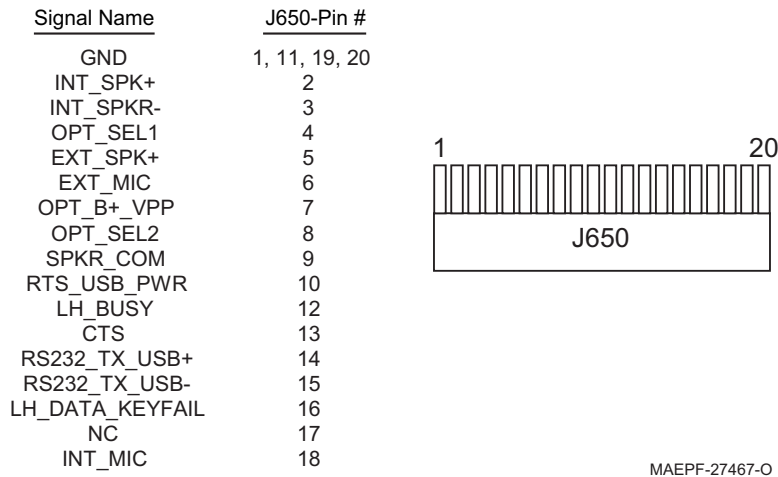

MAEPF-27467-O

Figure 4.5-3. VOCON Connector J650

Table 4.5-1. Option Select Functions

FUNCTION	Option Select 1	Option Select 2
External PTT	0	0
No Function (Normal)	1	1
Man Down	1	0
External Speaker	0	1

4.5.6.3.4 The Option Board

The Option Board consists of the "keypad module" and the "display module" for models II and III of the XTS 2500/XTS 2500I radio.

4.5.6.3.4.1 Display Module

An optional integral 96 pixels by 64 pixels LCD display module is available with either a 3 x 2 keypad with a navigational button (Model II radios), or 3 x 6 keypad with a navigational button (Model III radios). This unit is not considered field-repairable. The display module is connected to the VOCON section through the flex connector (J900).

The display is controlled by the Patriot's MCU core. The MCU core programs the display through the following:

- EIM data lines D0 - D7 (pins 9 through 16, respectively),
- the display chip select line (pin 5),
- the EIM "write only" line (pin 8), and
- the EIM address 0 line (pin 7).

The EIM address 0 is used to select the register to be programmed. The Patriot may reset the display module through pin 6. The display is supplied with 1.8 volts (C901) to pin 17 and 3 volts (C902) to pin 18.

The Patriot GPIO BL_EN controls the display backlighting; that signal goes to pin 43 of the J601 connector (on the radio board), and the corresponding pin 3 of the J901 connector (on the Option board).

Pin 4 of the J601 connector (on the radio board), and the corresponding pin 42 on the J901 connector (on the Option board) is supplied with 7.5 volts. The 7.5 volts is used to power the LEDs on the display module.

Pin 2 of the J601 connector (on the radio board), and the corresponding pin 44 on the J901 connector (on the Option board), is supplied with the V2 regulated voltage. The V2 regulated voltage is used to power DISPLAY_VCC.

Pin 1 of the J601 connector (on the radio board), and the corresponding pin 45 on the J901 connector (on the Option board), is supplied with 1.8 volts. The 1.8 volts is used to power DISPLAY_VDD.

4.5.6.3.4.2 Keypad Module

The keypad module is connected to the main board through flex connector (J601) on the radio board schematic and J901 on the Option board schematic. The keypad is read through a row-and-column matrix made up of ROW0, ROW1, ROW2, ROW3, ROW4, ROW5, ROW6 and COL0, COL1, and COL2. This totals 18 keys on the keypad. When a key is pressed, a row and a column are connected to one another.

The Patriot determines a key press by a scanning algorithm. Each column line is configured as an open drain output and pulled low. The Patriot then scans the row pins (each row pin has an internal pull up resistor). If a row signal is read low, then the Patriot determines that a key was pressed. If none of the row signal lines are low, then another column line is pulled low and the row scanning routine occurs.

The Patriot GPIO BL_EN controls the keypad backlighting; that signal goes to pin 43 of the J601 connector (on the radio board), and the corresponding pin 3 of the J901 connector (on the Option board). Pin 42 is supplied with 7.5 volts, which is used to power the LEDs on the keypad module.

4.5.6.3.5 Encryption Module

The encryption module (secure models only) connects directly to the VOCON board and interfaces directly with the vocoder digital circuitry. It contains one custom microcontroller IC (Armour) to perform digital, numerical, encryption algorithms.

The encryption modules are designed to digitally encrypt and decrypt voice for ASTRO and NON-ASTRO in XTS 2500/XTS 2500I. This section covers the encryption modules, hardware kits **0104020J49 (Model 1.5), 0104020J50 (Model 2) and 0104020J51 (Model 3)**.

NOTE: The encryption modules are NOT serviceable. The information contained in this section is only intended to help determine whether a problem is due to an encryption module or the radio itself.

The encryption module uses a custom encryption IC and an encryption key variable to perform its encode/decode function. The encryption key variable is loaded into the encryption module, via the radio's universal (side) connector, from a hand-held, key variable loader (KVL). The encryption IC corresponds to the particular encryption algorithm purchased. [Table 4.5-2](#) lists the encryption algorithms and their corresponding kit numbers.

The encryption module operates from two power supplies (UNSW_B+ and SW_B+). The SW_B+ is turned on and off by the radio's On/Off switch. The UNSW_B+ provides power to the encryption module as long as the radio battery is in place.

Key variables are loaded into the encryption module through connector J601, pin 34. Depending on the type of encryption module, up to 16 keys can be stored in the module at a time. The key can be infinite key retention or 30-seconds key retention, depending on how the codeplug is set up.

The radio's host processor communicates with the encryption module on the Synchronous Serial Interface (SSI) bus. The SSI bus consists of four signal lines. A communications failure between the host processor and the secure module will be *ERROR 09/10* or *S03 error* message on the display.

To troubleshoot the encryption module, refer to the flowcharts in [Chapter 6.5 "900 MHz Troubleshooting Charts."](#)

Table 4.5-2. Encryption Module Software Kits and Algorithms

Software Kit Number	Algorithm
Q667AB (7/800), Q667AE (V,U1,U2)	ADP SFWR DSP BASED CRYPTO
Q159AC	XTS 2500/XTS 2500I UCM HARDWARE ENCRYPTION
Q629AD	AES ENCRYPTION
Q625AU	DES, DES-XL, DES-OFB ENCRYPTION
Q668AC	ADP UCM ENCRYPTION W/DES, DES-XL, DES-OFB
H869BQ	MULTI KEY
Q406AC	ADP UCM ENCRYPTION
QA00204AA	MULTIKEY AND ADP
	ADP UCM ENCRYPTION W/AES

4.5.6.3.6 System Clocks

The Patriot is supplied with two clocks:

1. The first clock, a 16.8 MHz sine wave, comes from the RF portion of the radio. It is conditioned by the clock buffer circuit, which includes Q709, R722, R740, R743, R729, R797, C726, C725 and C727.
2. The other clock supplied to Patriot is a 32.768 kHz square wave. This clock is generated by the external 32.768kHz crystal Y701, and a clock buffer circuit that includes U713, R745, R746, C743, C792, R742 and R741. This signal is supplied to the CKIL pin on the dual-core processor.

4.5.6.4 Transmit Audio Path

Refer to [Figure 4.5-4](#). The single-ended internal microphone audio enters the VOCON board through 20 pin side connector (J650), and the internal microphone bias is set by circuitry that includes R751, R753, C751, C753 and C755. The internal microphone signal is connected to the INT_MIC_P pin, which is the input terminal on the MAKO IC internal op-amp G1 after the signal is multiplexed. The gain of the G1 pre-amp is set to +15 dB, which is programmed by dual-core processor SPI lines.

The external microphone audio enters the VOCON board through the remote connector J102, pin10, and the external microphone bias is set by circuitry that includes R750, R752, C750, C752 and C754. The external microphone signal is connected to the EXT_MIC_P pin, which is an input terminal on the MAKO IC internal op-amp G1 after the signal is multiplexed. The gain of the G1 pre-amp is set to +15 dB, which is programmed by dual-core processor SPI lines.

The dual-core processor, through the SPI bus, programs a multiplexer internal to the MAKO IC to select one of the microphone signals. Then, the selected microphone signal goes through the G1 pre-amplifier stage and on to a programmable gain amplifier (G2) before it goes to the CODEC for A/D conversion. The resulting digital data is filtered and sent to the DSP on the CODEC_TX line from the MAKO IC VC_TX3V pin. After additional filtering and processing, the DSP sends the data-out from the STDB pin, labeled TX_SSI_DATA to the RF interface connector.

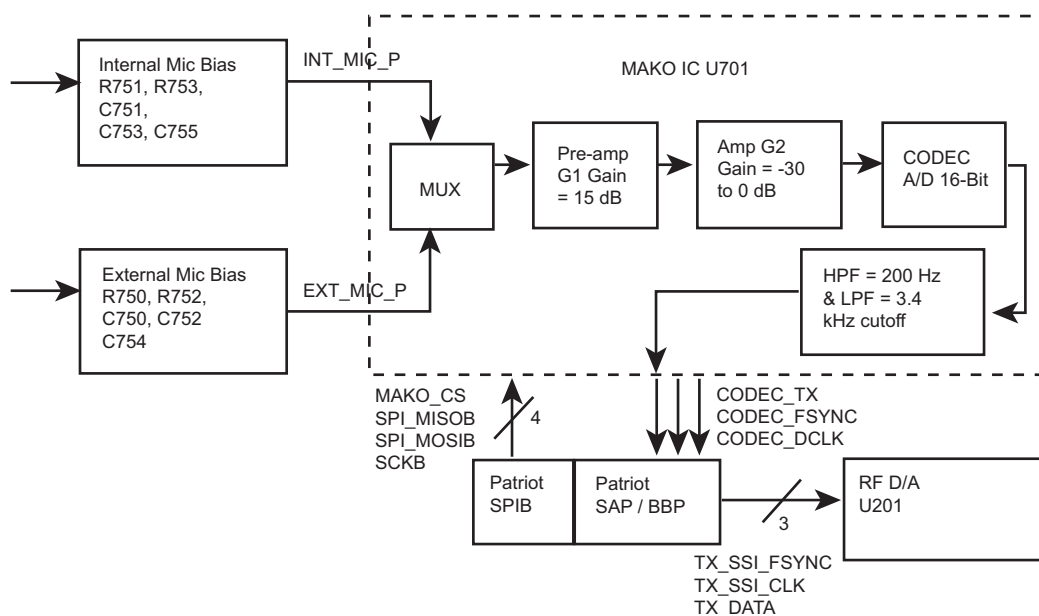

Figure 4.5-4. VOCON Transmit Audio Path

4.5.6.5 Receive Audio Path

Refer to [Figure 4.5-5](#). The receive audio data comes from the Abacus III IC U401 (DOUTA) to the dual-core processor SRDB pin. The DSP decodes the data and sends it out through the CODEC_RX line to the MAKO IC VC_RX3V pin. The CODEC filters, adds digital programmable gain G1, then converts the digital data into an analog audio signal, which in turn is sent to programmable attenuator G3. The signal is then sent through an internal programmable differential preamplifier (G4) to add gain and outputs the signal on pins VC_OUT_P and VC_OUT_M of the MAKO IC.

This output from the preamp is then filtered through circuitry R798, R844, C764, C765, C790, and then sent back to 2 independent internal BTL differential power amplifiers, G5 & G6, of the MAKO IC. The power amplifiers are programmed to a fixed gain of 26 dB through the dual-core processor SPI lines and PA control registers.

The dual-core processor selects whether the amplified audio is routed to the internal speaker or the external speaker through the SPI lines based upon which amplifier is turned on as shown in the PA control block. The output audio is routed on MAKO IC pins INT_SPKR_P and INT_SPKR_M for internal and EXT_SPKR_P and EXT_SPKR_M for external speaker lines.

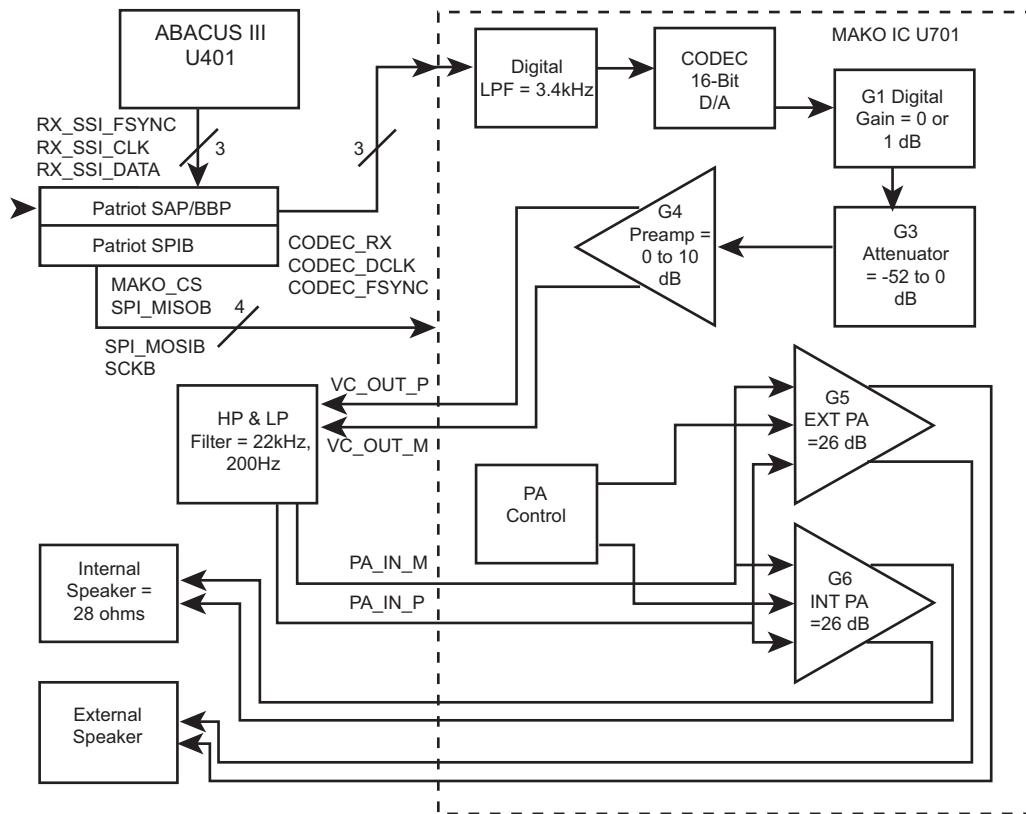

Figure 4.5-5. VOCON Receive Audio Path

Chapter 5 Troubleshooting Procedures

5.1 Introduction

The purpose of this chapter is to aid in troubleshooting problems with the ASTRO XTS 2500/XTS 2500I digital portable radio. It is intended to have enough detail to localize the malfunctioning circuit and isolate the defective component.



Most of the ICs are static sensitive devices. Do not attempt to troubleshoot or disassemble a board without first referring to the following Handling Precautions section.

Caution

This manual is to be used in conjunction with the ASTRO XTS 2500/XTS 2500I Digital Portable Radio Basic Service Manual (Motorola part number 6816984H01), which uses the pass/fail service approach to radio problems.

5.2 Handling Precautions

Complementary metal-oxide semiconductor (CMOS) devices, and other high-technology devices, are used in this family of radios. While the attributes of these devices are many, their characteristics make them susceptible to damage by electrostatic discharge (ESD), or high-voltage charges. Damage can be latent, resulting in failures occurring weeks or months later. Therefore, special precautions must be taken to prevent device damage during disassembly, troubleshooting, and repair. Handling precautions are mandatory for this radio, and are especially important in low-humidity conditions. DO NOT attempt to disassemble the radio without observing the following handling precautions:

1. Eliminate static generators (plastics, Styrofoam, etc.) in the work area.
2. Remove nylon or double-knit polyester jackets, roll up long sleeves, and remove or tie back loose hanging neckties.
3. Store and transport all static-sensitive devices in ESD-protective containers.
4. Disconnect all power from the unit before ESD-sensitive components are removed or inserted, unless otherwise noted.
5. Use a static-safeguarded workstation. We recommend using a wrist strap, two ground cords, a static-control table mat, and a static-control floor mat.
6. Always wear a conductive wrist strap when servicing this equipment. The Motorola part number for a replacement wrist strap that connects to the table mat is 4280385A59.
7. When performing hot-air repair in close proximity to the backup battery (reference number M500), remove the backup battery before performing any rework to avoid damaging the battery.

5.3 Voltage Measurement and Signal Tracing

It is a good idea to check the battery voltage under load. This can be done by measuring the OPT_B+ _VPP pin at the universal (side) connector (pin 4). The battery voltage should remain at or above 7.0 Vdc. If the battery voltage is less than 7.0 Vdc, the battery should be recharged or replaced, as necessary, prior to analyzing the radio.

In most situations, the problem circuit may be identified using a multimeter, RF millivoltmeter, oscilloscope (preferably with 100 MHz bandwidth or more), and a spectrum analyzer.



When checking a transistor or module, either in or out of circuit, do not use an ohmmeter having more than 1.5 volts dc appearing across the test leads, or use an ohms scale of less than x100.

Caution

5.4 Standard Bias Table

Table 5-1 outlines some standard supply voltages and system clocks that should be present under normal operation. These should be checked as a first step to any troubleshooting procedure.

Table 5-1. Standard Operating Bias

Signal Name	Nominal Value	Tolerance	Probe Point
Gated_32_KHZ	32.768kHz	±400ppm	C742
CKIH	16.8MHz		C726
16.8MHZ	16.8MHz		C726
POR	2.9V dc	±5%	D511, pin 2
MAKO_RESET	1.9V dc	±5%	D511, pin 2
VSW1	3.6V dc	±5%	R711
VSW2	2.3V dc	±5%	C715
V2.9	2.9V dc	±5%	L704
UNSW_B+	7.5V dc	6-9 V dc	R725
SW_B+	7.5V dc	6-9 V dc	R708
VCC5	5V dc	±5%	L705
VSAVE	2.5V dc	±5%	C704
RFSW_B+	7.5V dc	6-9 V dc	C730

5.5 Power-Up Self-Check Errors

Each time the radio is turned on, the microcontroller unit (MCU) and the digital signal processor (DSP) perform some internal diagnostics. These diagnostics consist of checking the programmable devices such as the FLASH ROMs, internal and external EEPROMs, and SRAM devices. At the end of the power-up self-check routines, if an error exists, the appropriate error codes may be read using the Customer Programming Software (CPS) from the RS232/USB bus on the universal (side) connector.

Table 5-2. Power-up Self-Check Error Codes

Error Code	Description	Corrective Action
01/02	FLASH ROM codeplug Checksum Non-Fatal Error	1) Turn radio off, then on. 2) Reprogram the radio codeplug.
01/12	Security Partition Checksum Non-Fatal Error	Send radio to depot
01/20	ABACUS Tune Failure Non-Fatal Error	Turn radio off, then on
01/22	Tuning Codeplug Checksum Non-Fatal Error	Send radio to depot
01/81	Host ROM Checksum Fatal Error	Send radio to depot
01/82	FLASH ROM codeplug Checksum Fatal Error	Reprogram the codeplug, then retune the radio.
01/88	External RAM Fatal Error (Note: Not a checksum error.)	Send radio to depot
01/90	General Hardware Failure Fatal Error	Turn radio off, then on
01/92	Security Partition Checksum Fatal Error	Send radio to depot
01/93	FLASHport Authentication Code Failure	Send radio to depot
01/98	Internal RAM Fail Fatal Error	Send radio to depot
01/A2	Tuning Codeplug Checksum Fatal Error	Send radio to depot
02/81	DSP ROM Checksum Fatal Error	Send radio to depot
02/88	DSP RAM Fatal Error (Note: Not a checksum error.)	Turn radio off, then on
02/90	General DSP Hardware Failure (DSP startup message not received correctly)	Turn radio off, then on.

NOTE: If you have an earlier version of the radio, it may display either 09/10 or 09/90. This is the result of a programming error, and can be cleared by turning the radio off and on. If the problem persists, send the radio to the depot. Newer radios will not display this error code.

In the case of multiple errors, the codes are logically ORed and the results displayed.

5.6 Operational Error Codes

During radio operation, the radio performs dynamic tests to determine if the radio is working properly. Problems detected during these tests are presented as error codes on the radio's display. The presence of an error code should prompt a user that a problem exists and that a service technician should be contacted. Use [Table 5-3](#) to aid in understanding particular operational error codes.

Table 5-3. Operational Error Code Displays

Error Code	Description	Corrective Action
FAIL 001	Synthesizer Out-of-Lock	a. Reprogram external codeplug b. Send radio to depot
FAIL 002	Selected Mode/Zone Codeplug Checksum Error	Reprogram external codeplug

5.6.1 Power-Up, Self-Check Diagnostics, and Repair (Not for Field Use)

The following are additional action items to be utilized for the diagnosis and resolution of the aforementioned error codes:

Table 5-4. Additional Error Code Action Items

Error Code	Corrective Action
01/02	This non-fatal error will likely recover if the radio's power is cycled. In the event that this does not resolve the issue, the radio should be re-flashed. As a last resort, the FLASH ROM (U803) should be replaced.
01/12	The radio should be sent to the depot for re-flashing of the security codeplug.
01/20	Cycling the radio power should resolve this issue.
01/22	The radio should be sent to the depot for re-flashing of the tuning codeplug, followed by re-tuning of the radio.
01/81	The radio should be sent to the depot for re-flashing of the host code.
01/82	The radio should be sent to the depot for re-flashing of the radio codeplug.
01/88	Re-flashing of the radio should be performed first. If this fails to resolve the issue, then replacement of the SRAM (U804) is necessary.
01/90	Cycle power to the radio. Continued failure indicates a likely IC failure (MAKO, PCIC, ABACUS). In this event, the radio should be sent to the depot for isolation and repair of the problem IC.
01/92	The radio should be sent to the depot for reprogramming of the security codeplug.
01/93	The radio should be sent to the depot for re-flashing of the host code.
01/98	Send the radio to the depot for replacement of the SRAM (U804).
01/A2	The radio should be sent to the depot for re-flashing of the tuning codeplug followed by re-tuning of the radio.
02/81	The radio should be sent to the depot for examination and/or replacement of either the FLASH (U804), or the Patriot MCU/DSP (U800).

Table 5-4. Additional Error Code Action Items (Continued)

Error Code	Corrective Action
02/88	Cycle power to the radio. If this does not fix the problem, then the radio should be sent to the depot for re-flashing of the DSP code. Continued failure requires examination and/or replacement of the SRAM (U804).
02/90	Cycle power to the radio. If this fails to fix the problem, then the radio should be sent to the depot for re-flashing of the DSP code. Continued failure may require replacement of U800, the Patriot MCU/DSP.

Notes

Chapter 6.1 VHF Troubleshooting Charts

6.1.1 Introduction

This chapter contains detailed troubleshooting flowcharts. These flowcharts are for use as a guide in determining the problem areas. They are not a substitute for the knowledge of circuit operation and astute troubleshooting techniques. It is advisable to refer to the related detailed circuit descriptions in the theory sections prior to troubleshooting a radio.

This manual is to be used in conjunction with the ASTRO XTS 2500/XTS 2500I Digital Portable Radios Basic Service Manual (Motorola part number 6816984H01), which uses the pass/fail service approach to radio problems.

6.1.2 List of Troubleshooting Flowcharts

Most troubleshooting flowcharts end up by pointing to an IC to replace. **It is not always noted, but it is good practice to verify supplies and grounds to the affected IC and to trace continuity to the malfunctioning signal and related circuitry before replacing any IC.** For instance, if a clock signal is not available at a destination IC, continuity from the source IC should be checked before replacing the source IC.

Table 6.1-1. List of Troubleshooting Flowcharts

Chart Name	Page No.
VHF Radio Main Troubleshooting Chart	6.1-2
Radio Power-Up Fail Troubleshooting Chart	6.1-3
DC Supply Fail Troubleshooting Chart	6.1-6
Button Test Troubleshooting Chart	6.1-9
Volume Set Error Troubleshooting Chart	6.1-10
Zone/Channel Select Error Troubleshooting Chart	6.1-11
Top/Side Button Error Troubleshooting Chart	6.1-12
No Display Troubleshooting Chart	6.1-13
VHF Receive RF Troubleshooting Chart	6.1-16
VOCON Receive Audio Troubleshooting Chart	6.1-17
VHF Frequency Generation Unit Troubleshooting Chart	6.1-18
VOCON Transmit Audio Troubleshooting Chart	6.1-19
No Transmit Deviation Troubleshooting Chart	6.1-21
VHF Transmitter RF Troubleshooting Chart	6.1-22
Secure Hardware Failure	6.1-23

NOTE: μC is used in several of the following troubleshooting charts.
 μC = microcontroller unit (MCU).

6.1.3 VHF Radio Main Troubleshooting Chart

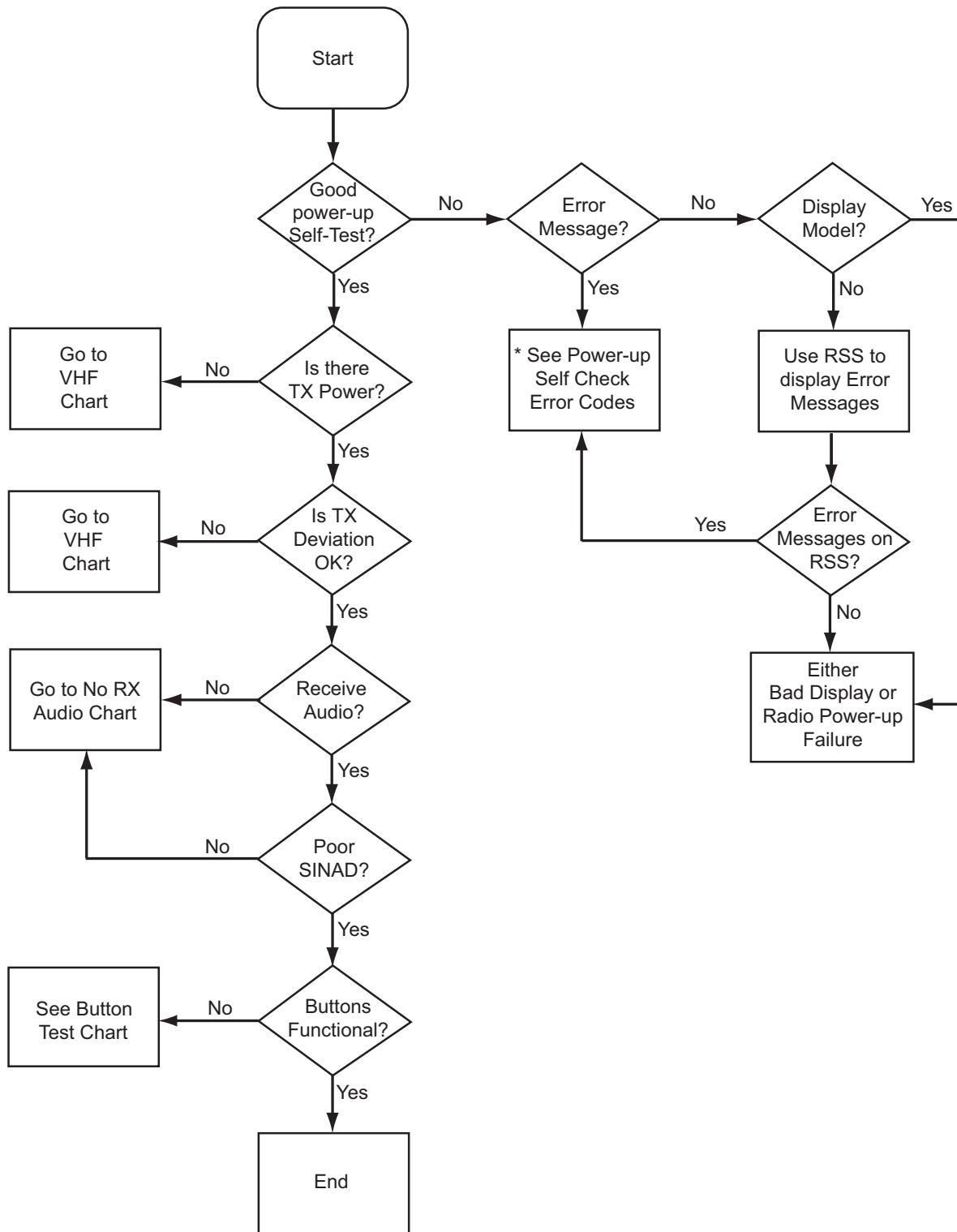

*Please see [Table 5-2 on page 5-3](#).

6.1.4 Radio Power-Up Fail Troubleshooting Chart (1 of 3)

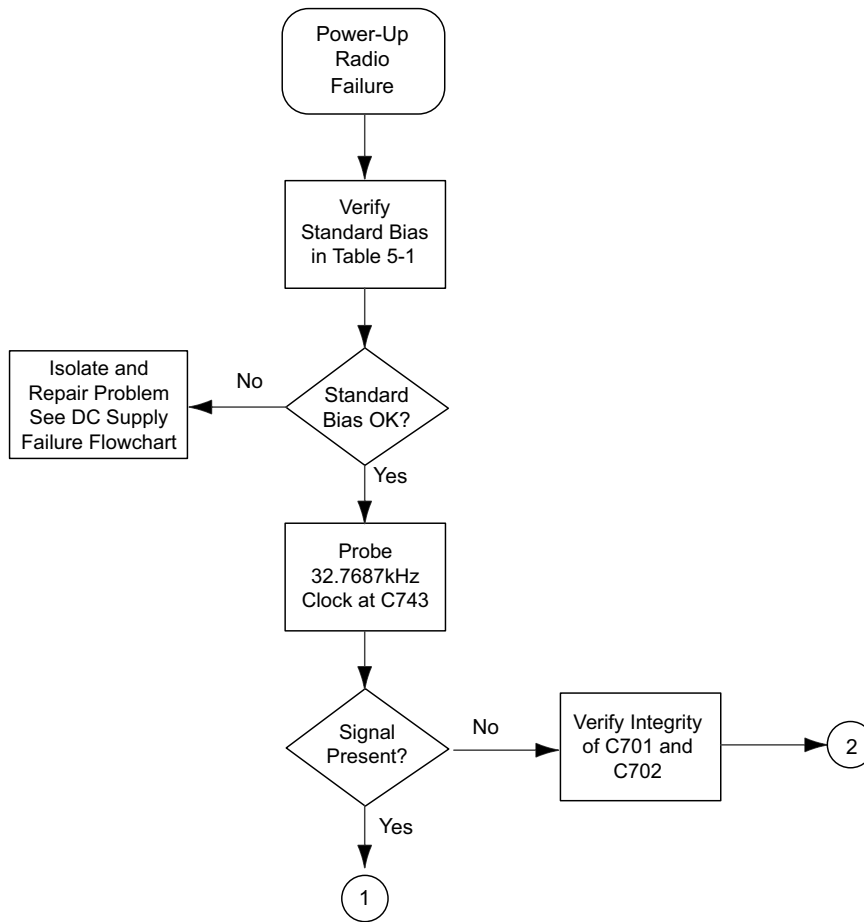

6.1.5 Radio Power-Up Fail Troubleshooting Chart (2 of 3)

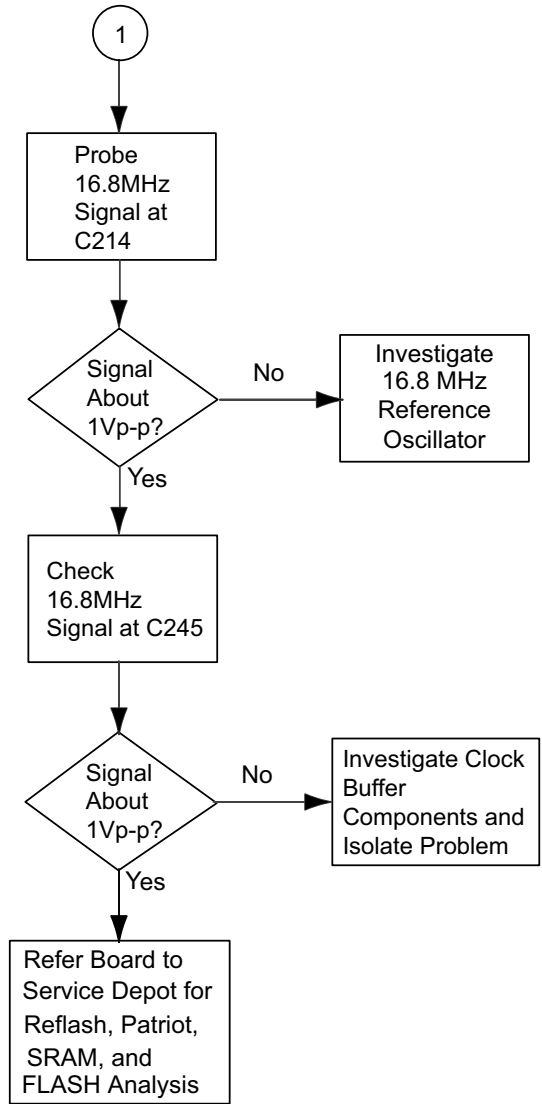

6.1.6 Radio Power-Up Fail Troubleshooting Chart (3 of 3)

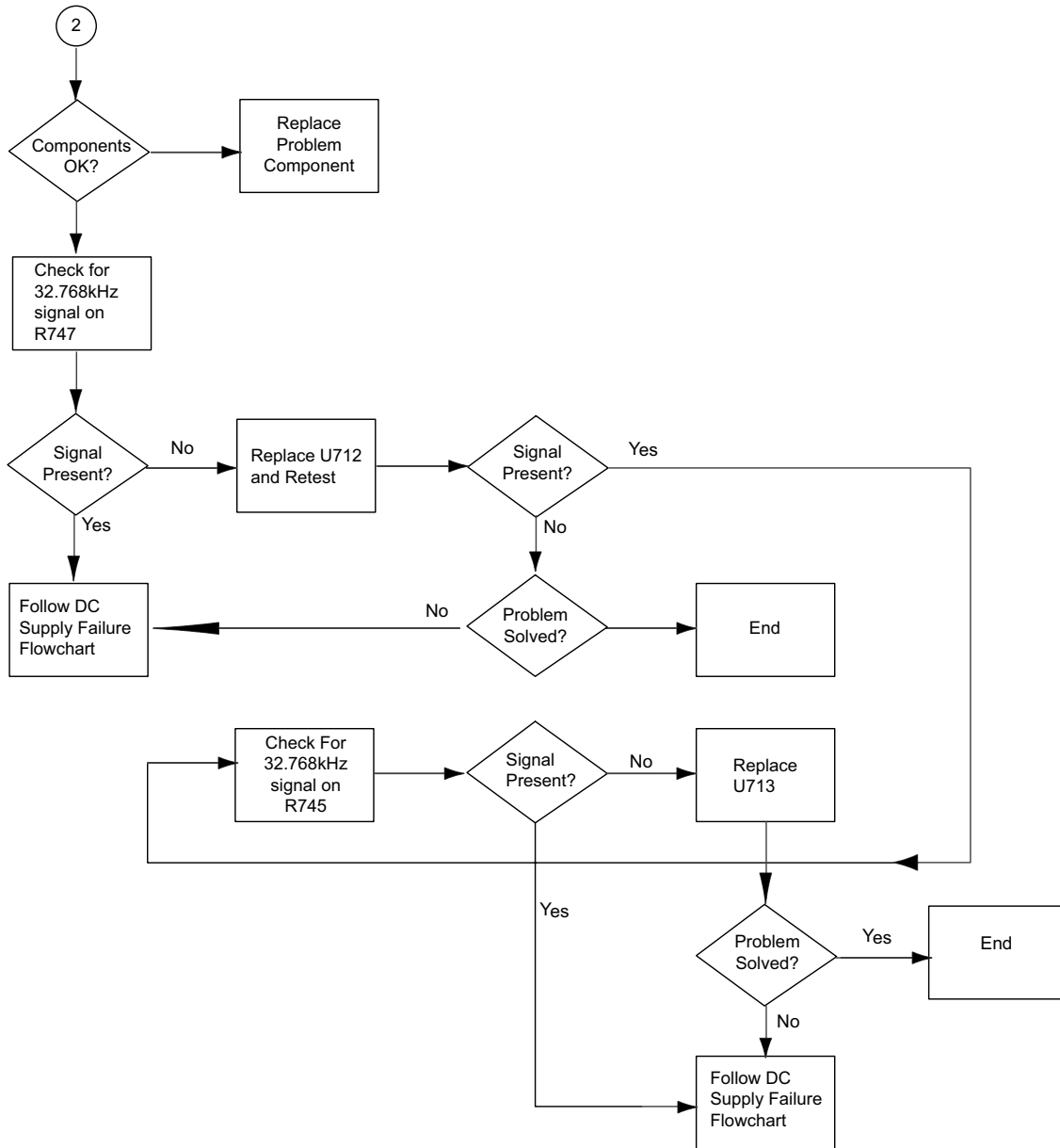

MAEPF-27333-O

6.1.7 DC Supply Fail Troubleshooting Chart (1 of 3)

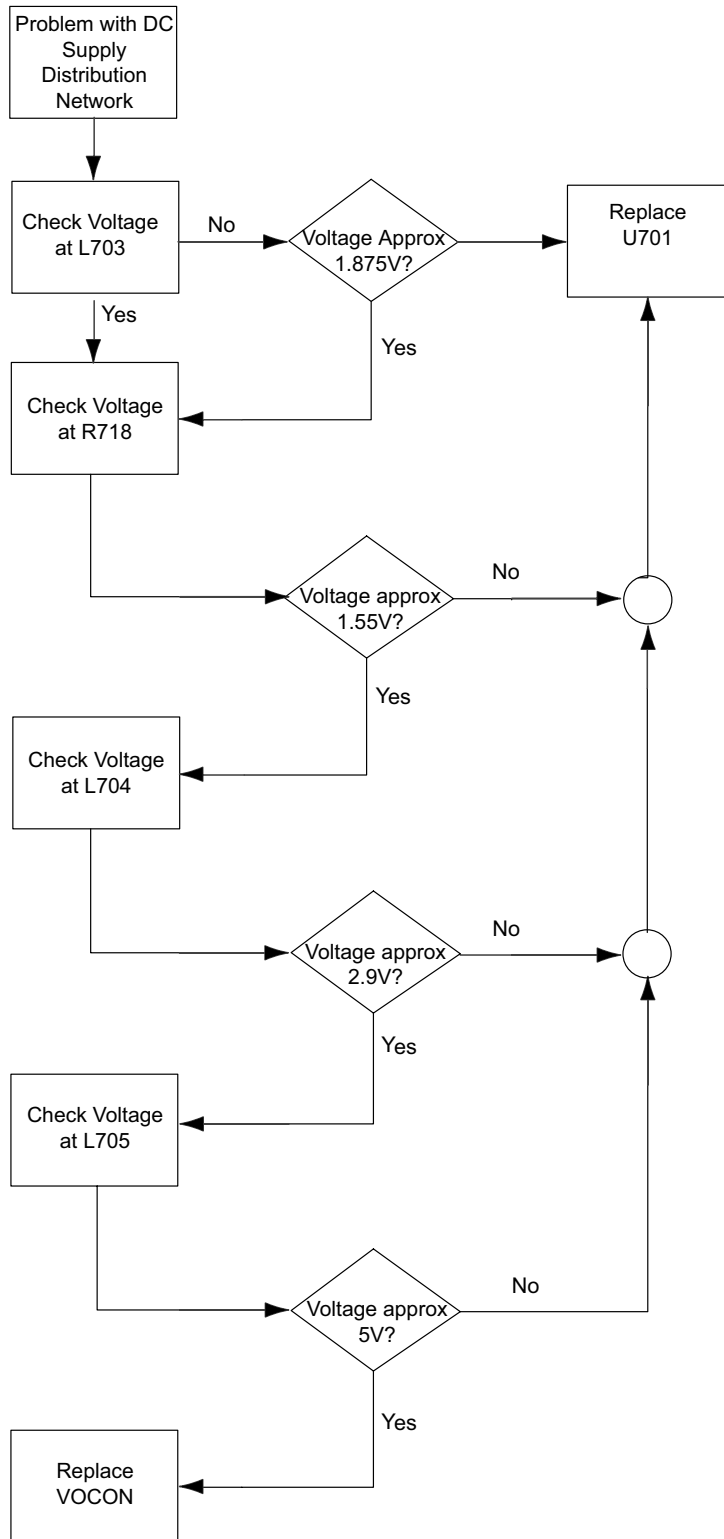

MAEPF-27334-O

6.1.8 DC Supply Fail Troubleshooting Chart (2 of 3)

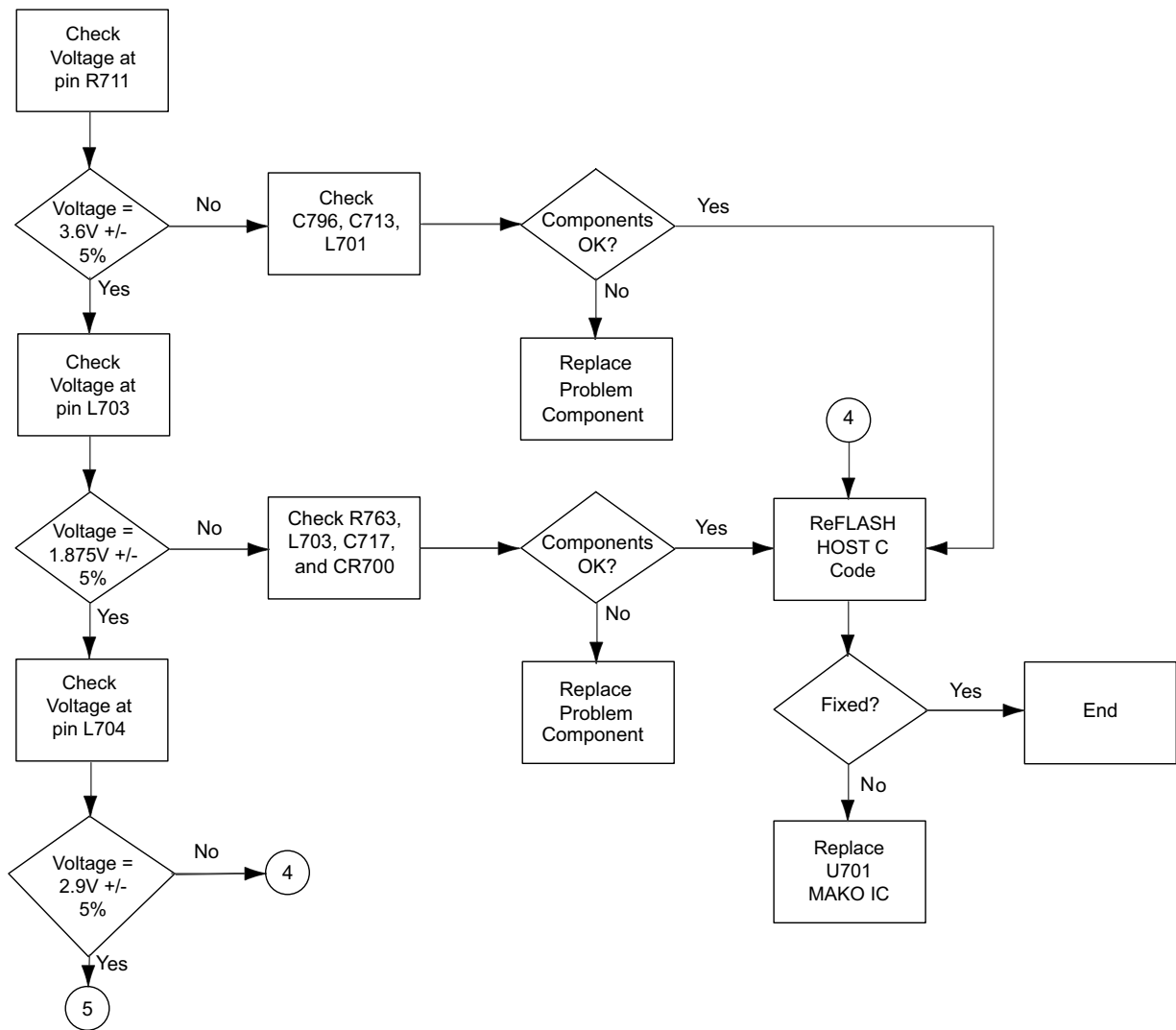

MAEPF-27333-O

6.1.9 DC Supply Fail Troubleshooting Chart (3 of 3)

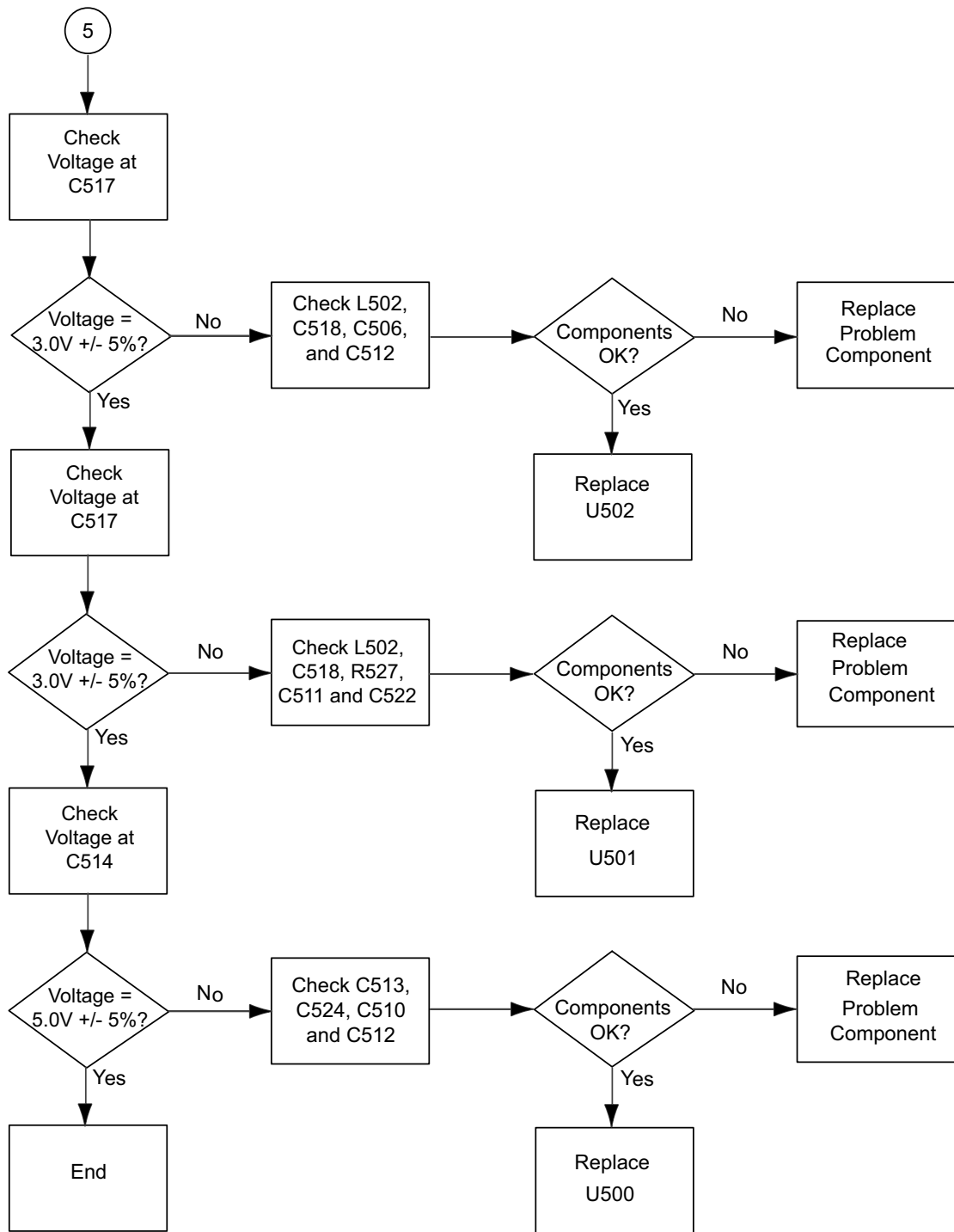

6.1.10 Button Test Troubleshooting Chart

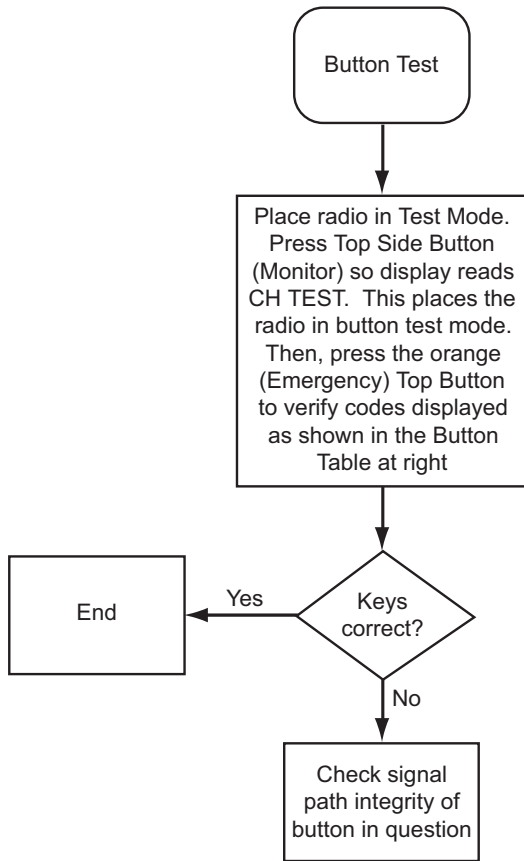

Synopsis

This chart relates to a failure in the button functions. Basic Failure modes are as follows:

- 1) Failure in keypad flex assembly.
- 2) Bad Connection
- 3) Defective Switches or pads
- 4) Defective MAKO IC (U701)

Button Table

Button	Code	Chart
PTT	1/ 0-1	
Top Button (Emergency)	3/ 0-1	C.6
Side Button 1 (Monitor)	96/ 0-1	C.6
Side Button 2	97/ 0-1	C.6
Side Button 3	98/ 0-1	C.6
Channel Select (Frequency)	4/ 0-15	C.8
Volume Control Knob	0/ 0-220	C.7
Zone Select	65/ 0-2	C.8

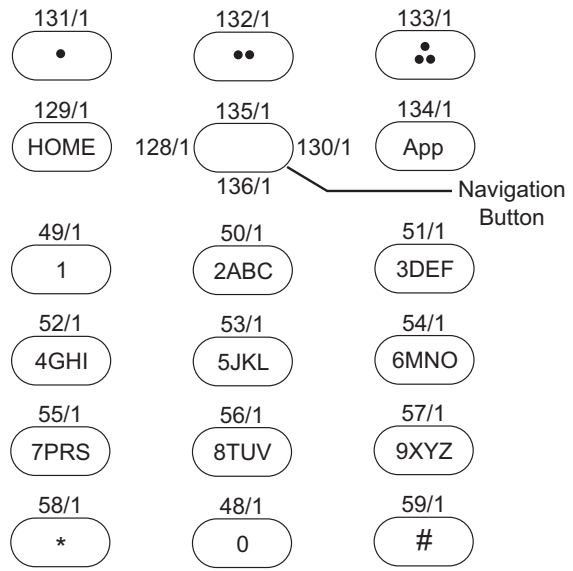

MAEPF-27335-O

6.1.11 Volume Set Error Troubleshooting Chart

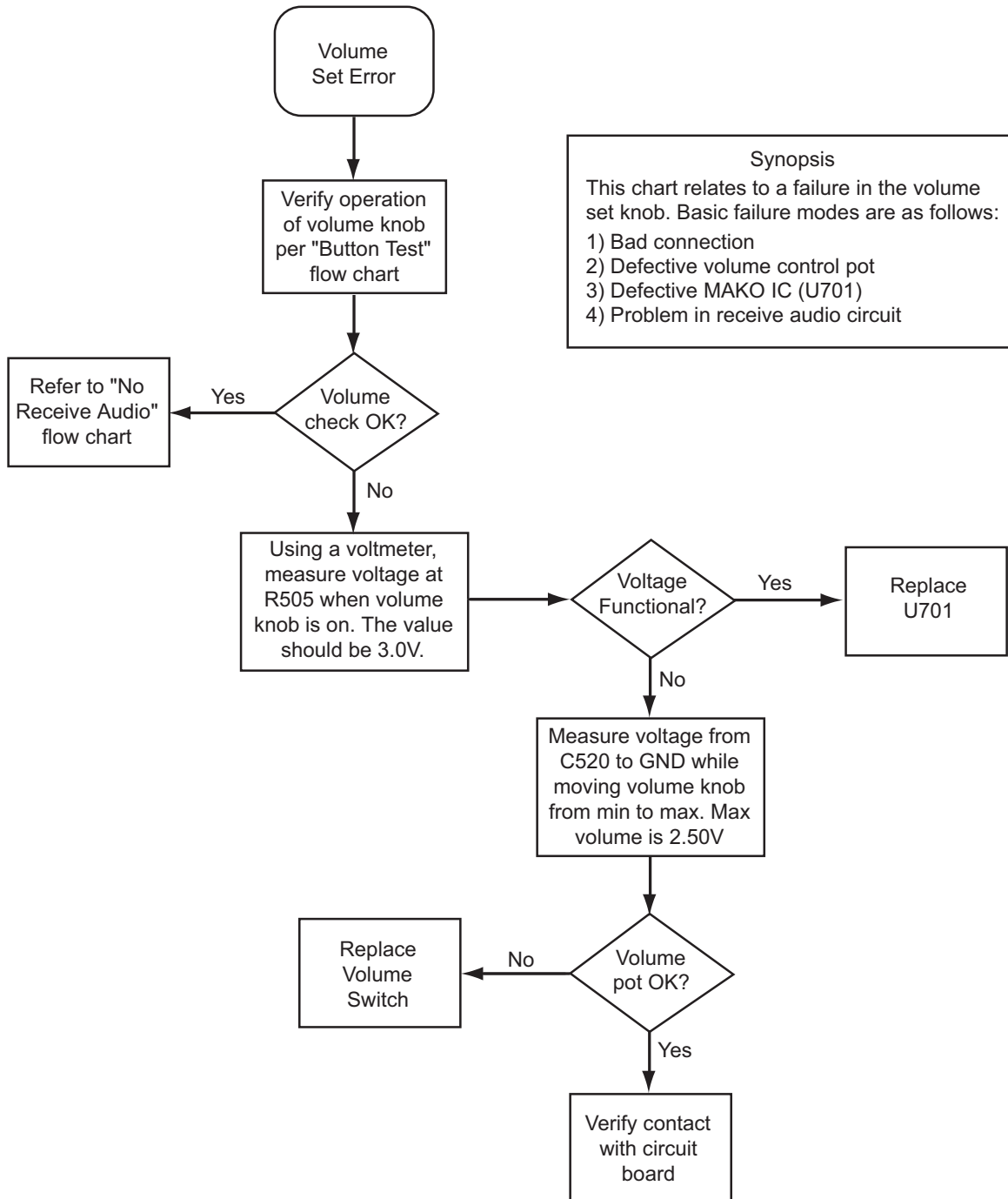

Synopsis
 This chart relates to a failure in the volume set knob. Basic failure modes are as follows:
 1) Bad connection
 2) Defective volume control pot
 3) Defective MAKO IC (U701)
 4) Problem in receive audio circuit

MAEPF-27336-O

6.1.12 Zone/Channel Select Error Troubleshooting Chart

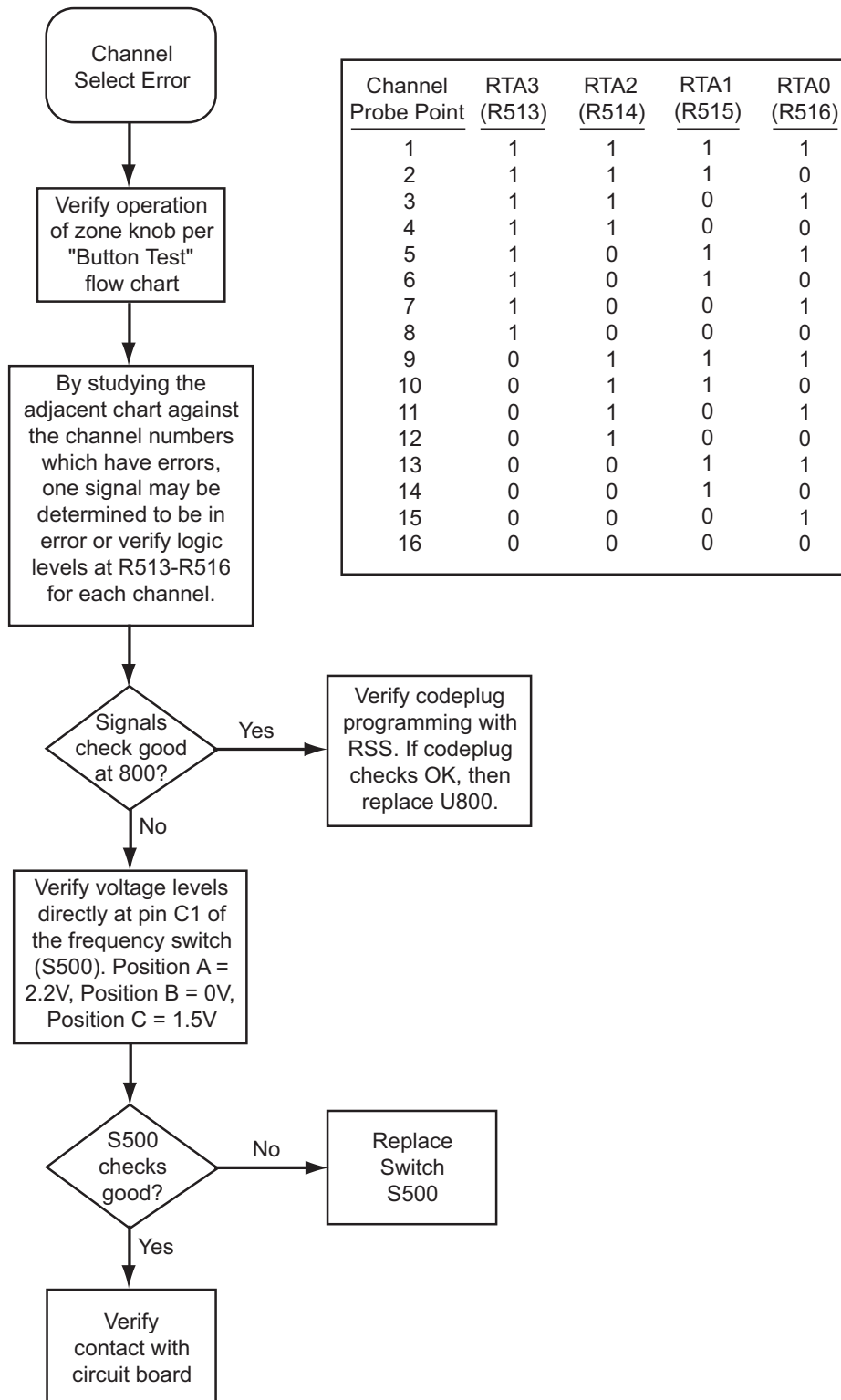

MAEPF-27337-O

6.1.13 Top/Side Button Error Troubleshooting Chart

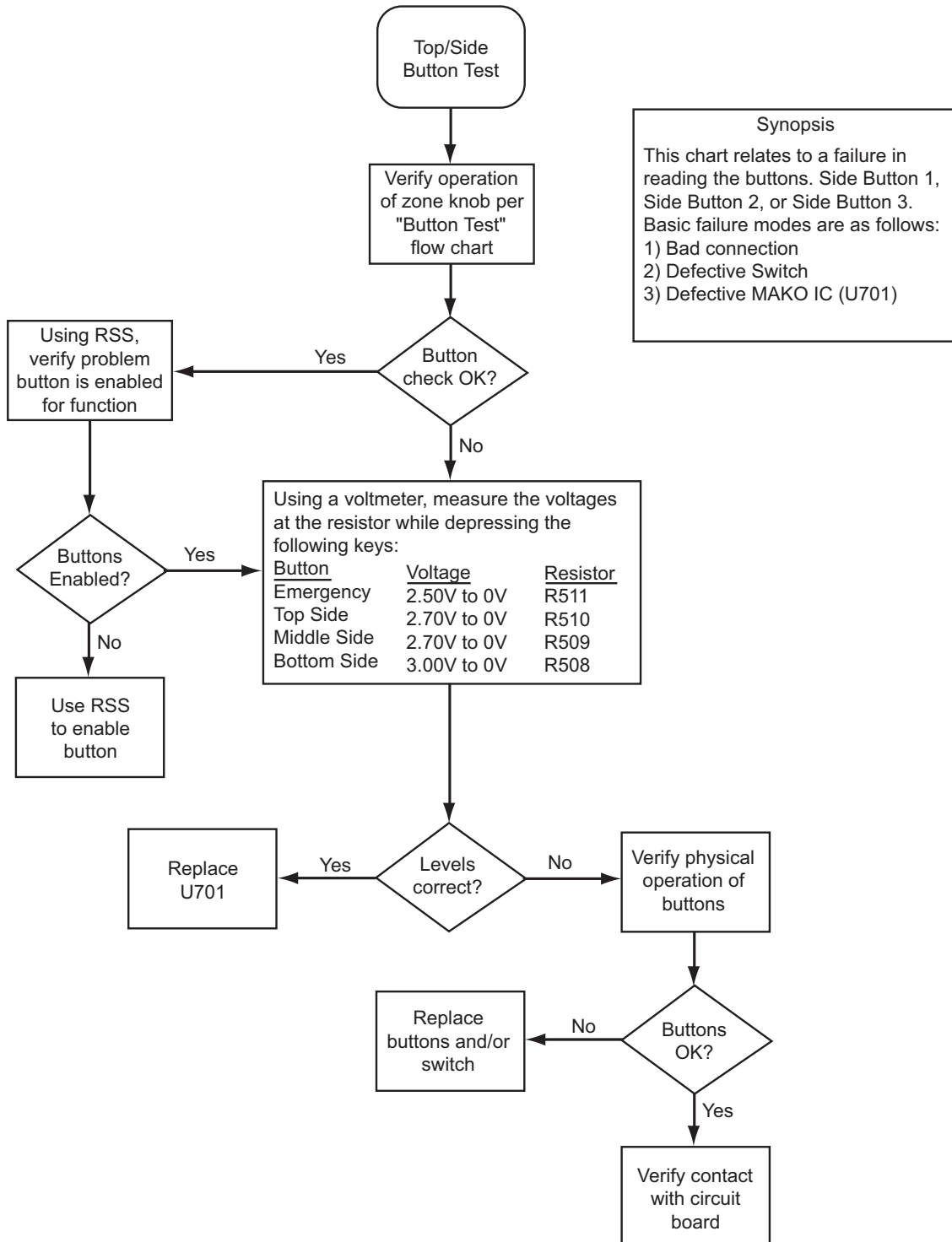

MAEPF-27338-O

6.1.14 No Display Troubleshooting Chart (1 of 3)

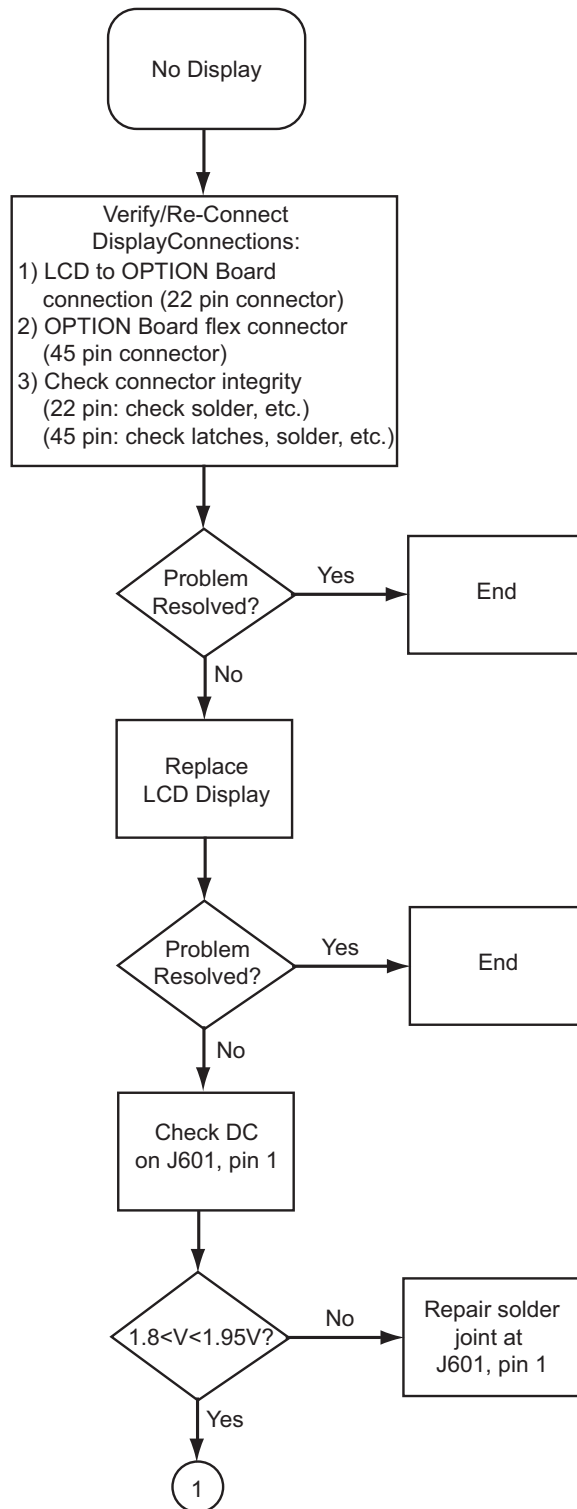

MAEPF-27339-O

6.1.15 No Display Troubleshooting Chart (2 of 3)

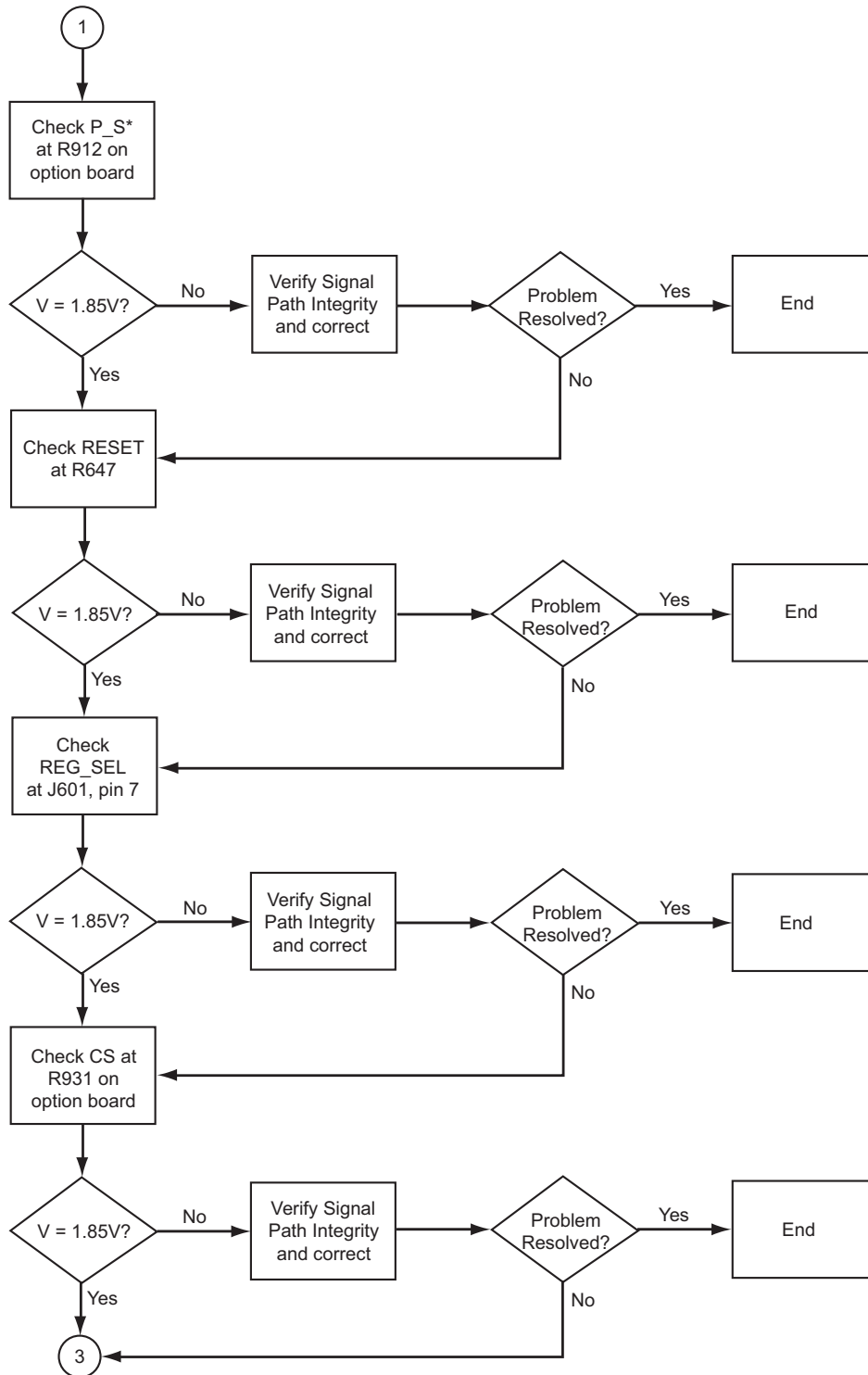

MAEPF-27340-O

6.1.16 No Display Troubleshooting Chart (3 of 3)

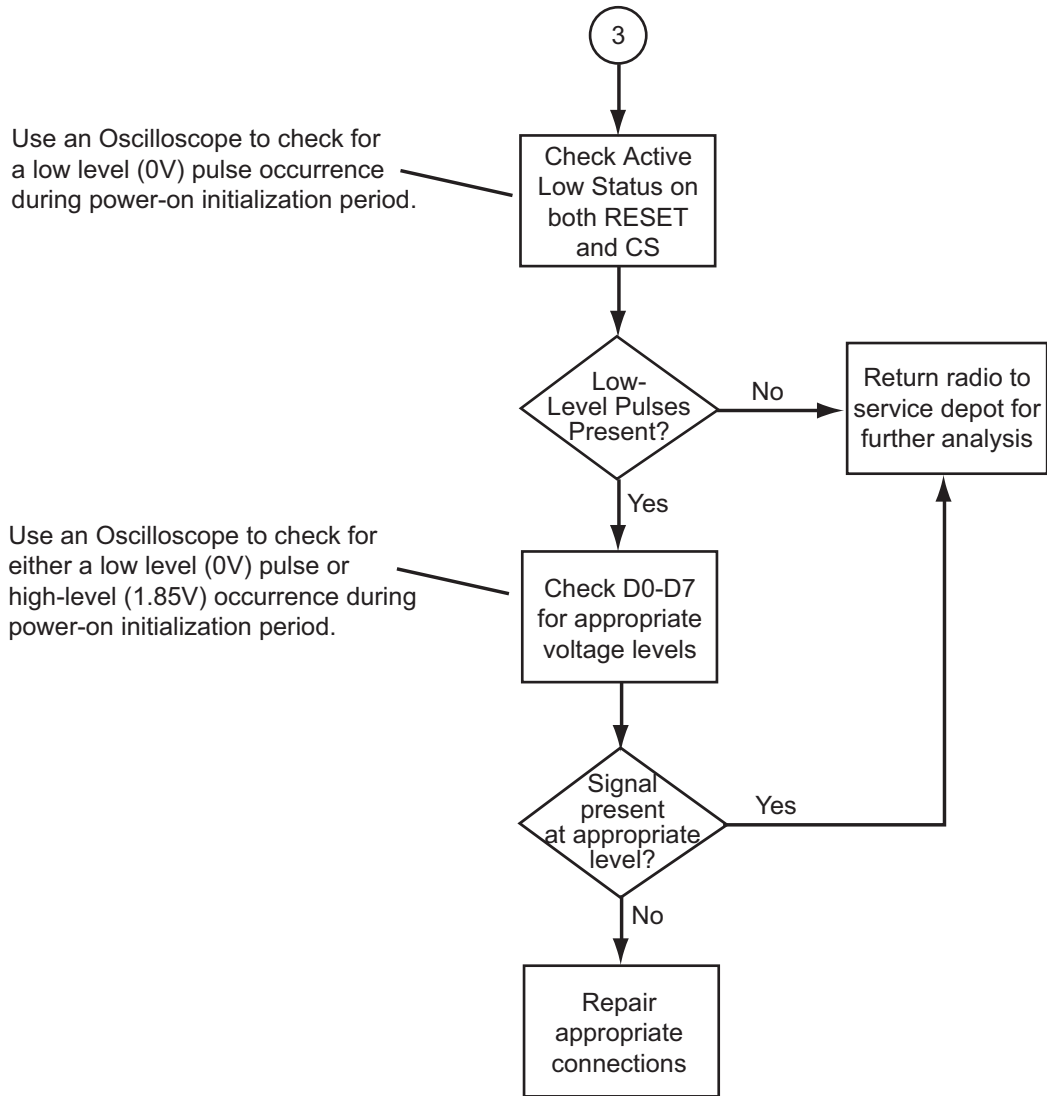

MAEPF-27341-O

6.1.18 VOCON Receive Audio Troubleshooting Chart

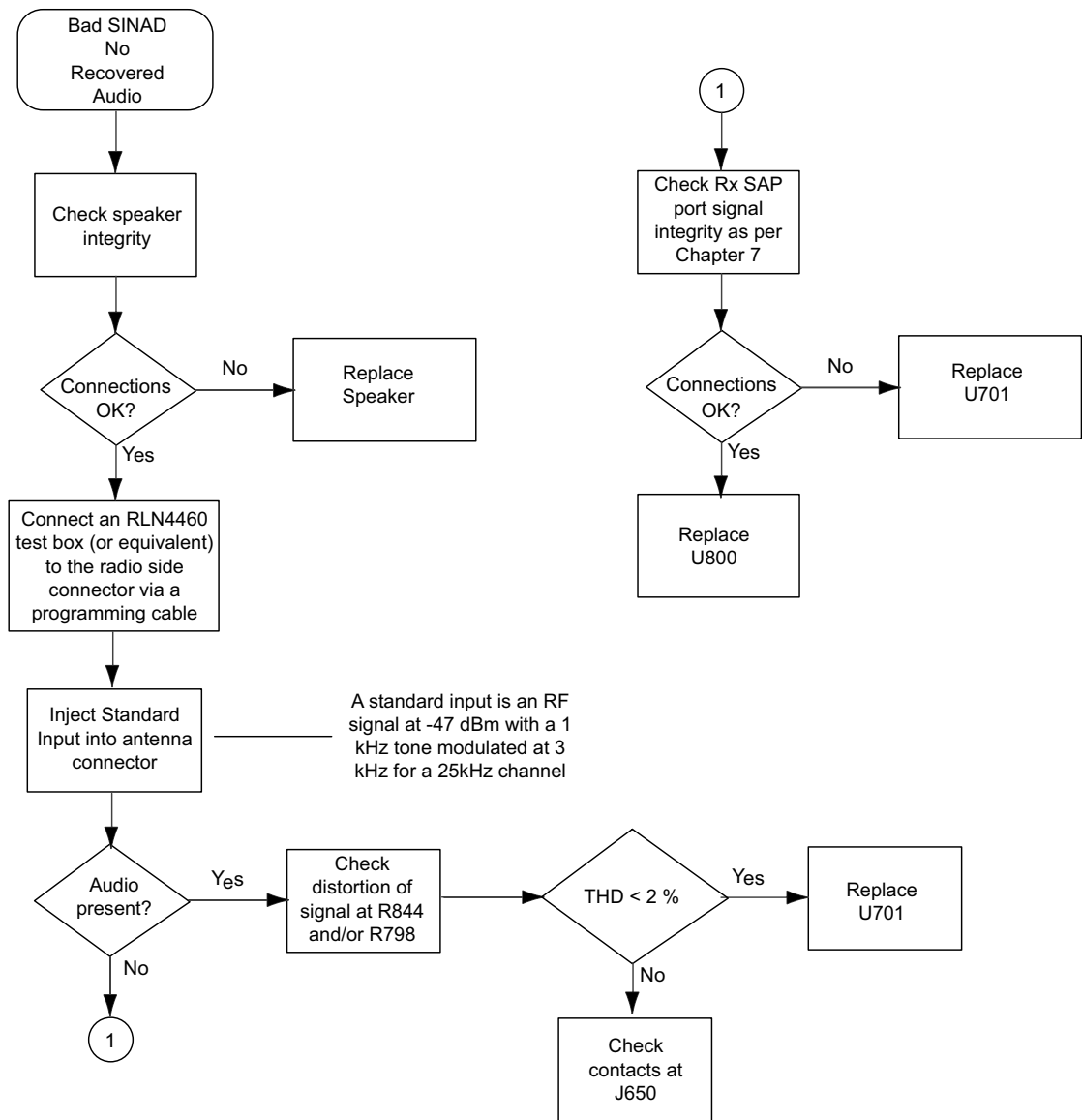

MAEPF-27347-O

6.1.19 VHF Frequency Generation Unit Troubleshooting Chart

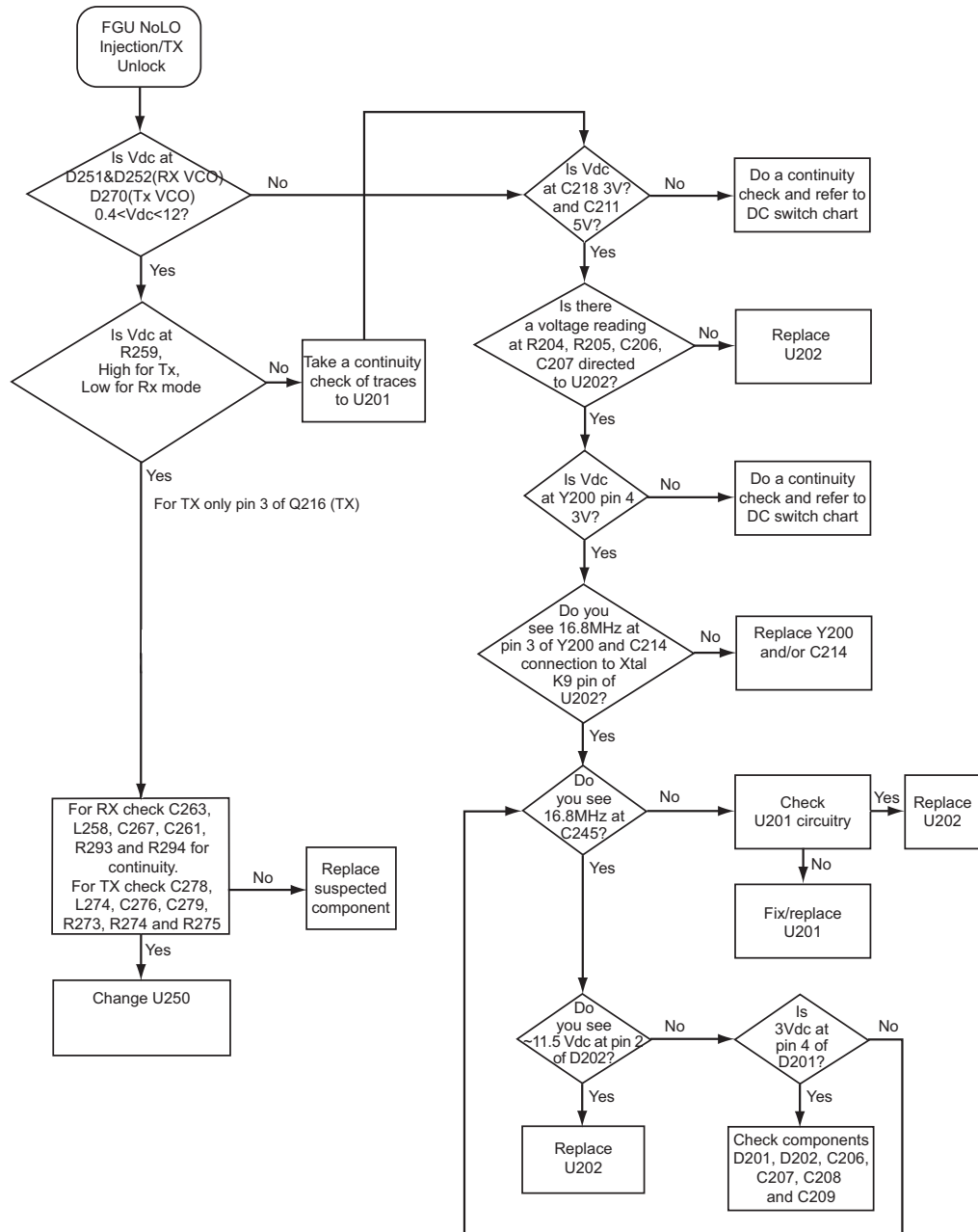

MAEPF-27346-O

6.1.20 VOCON Transmit Audio Troubleshooting Chart (1 of 2)

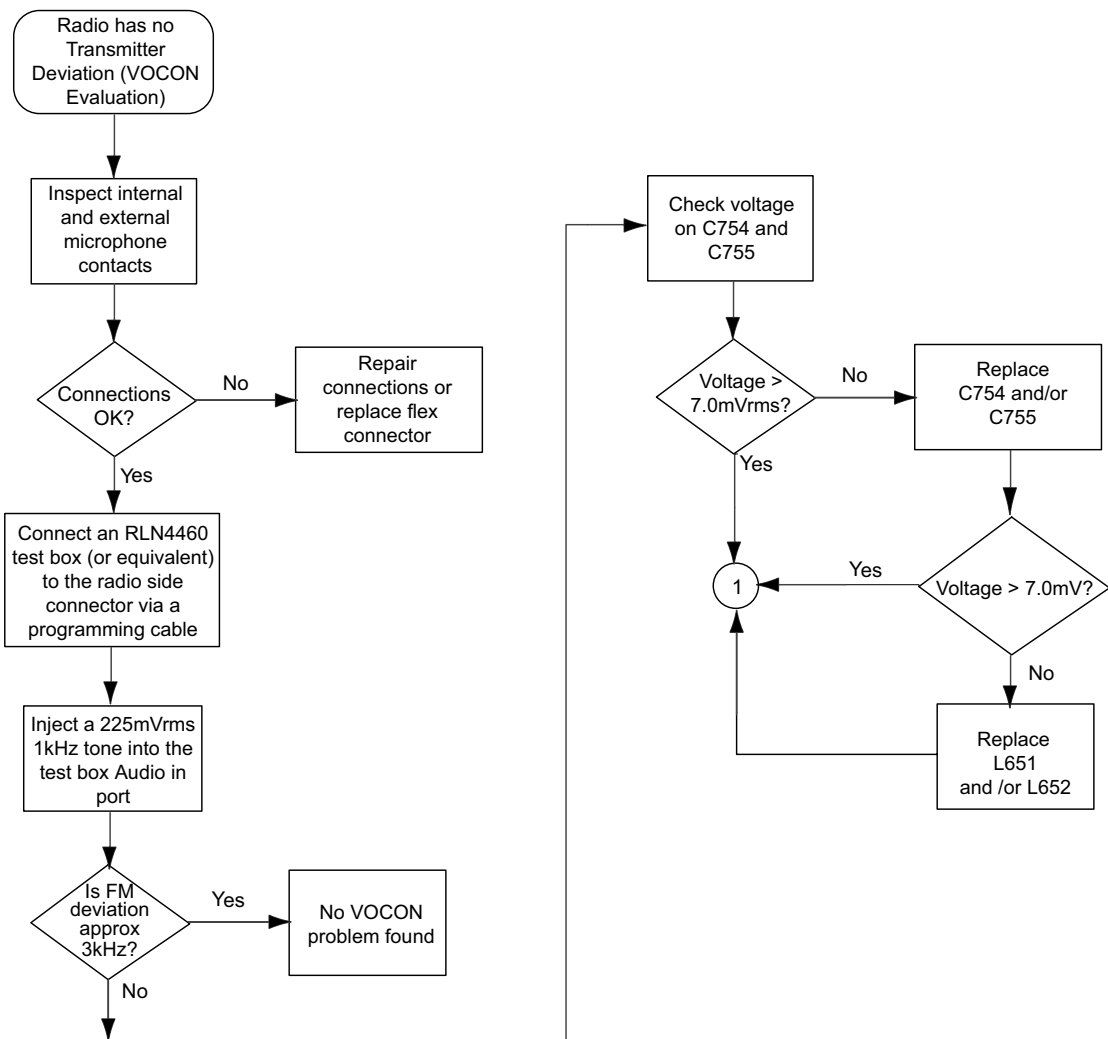

MAEPF-27347-O

6.1.21 VOCON Transmit Audio Troubleshooting Chart (2 of 2)

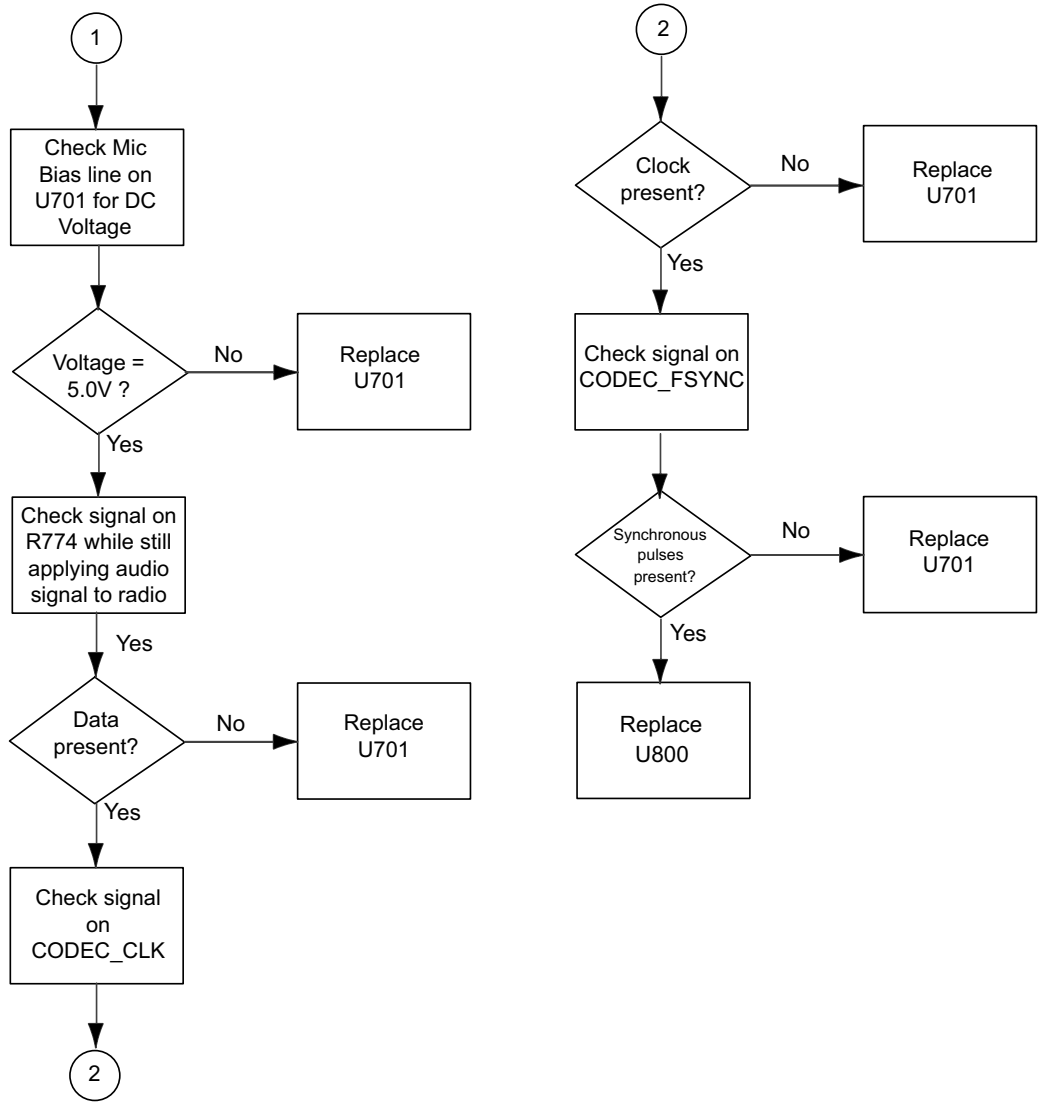

MAEPF-27334-O

6.1.22 No Transmit Deviation Troubleshooting Chart

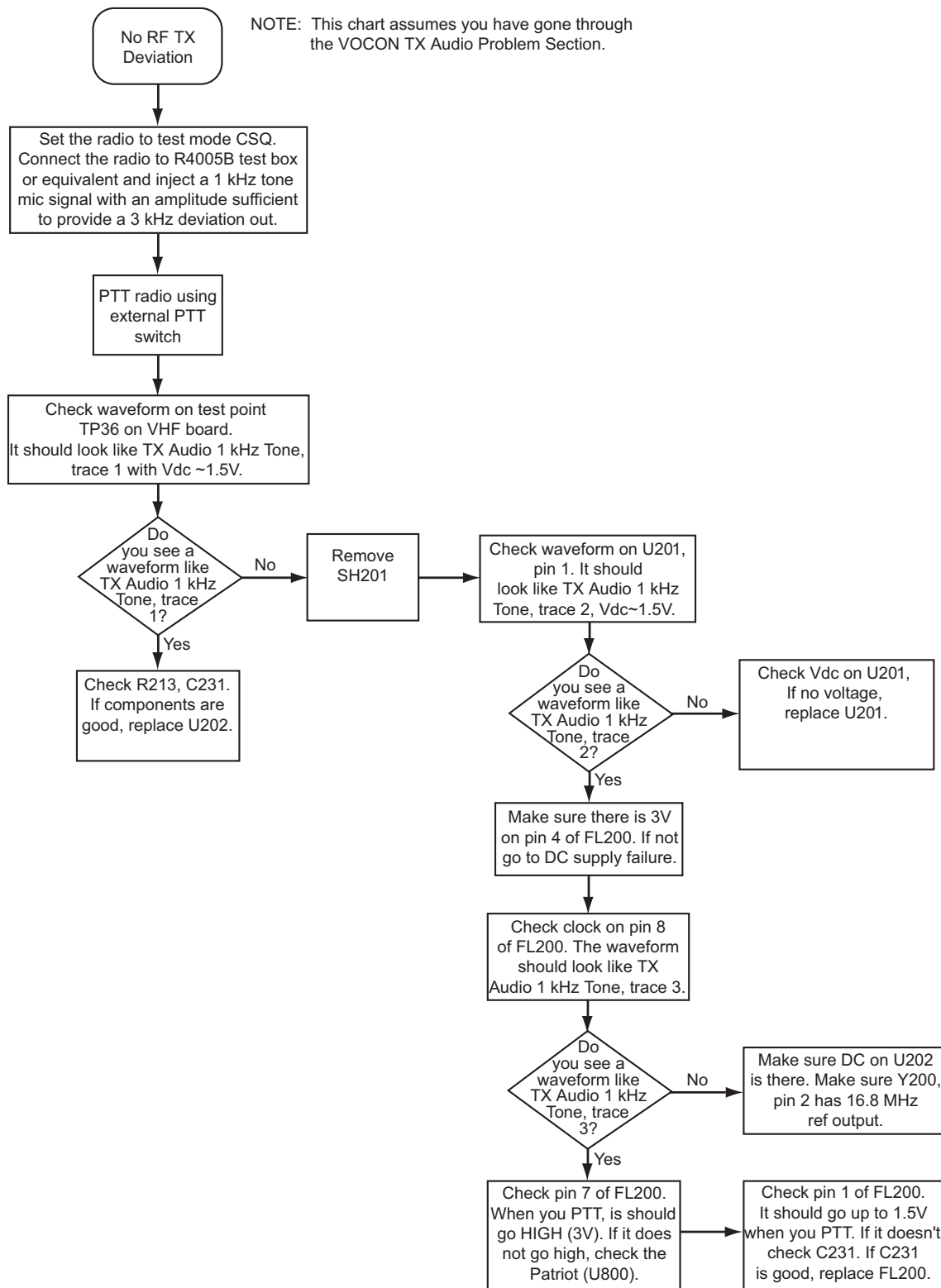

MAEPF-27343-O

6.1.23 VHF Transmitter RF Troubleshooting Chart

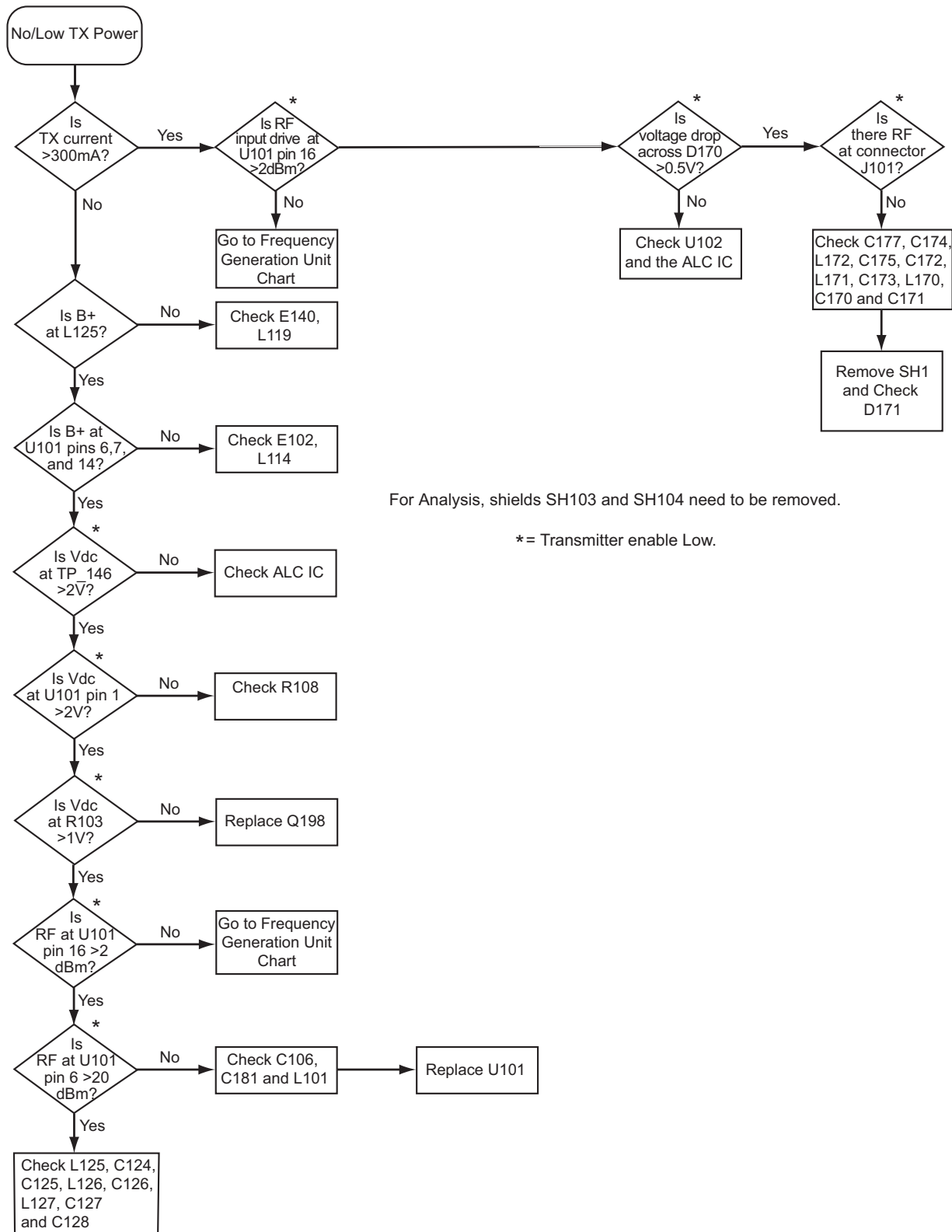

For Analysis, shields SH103 and SH104 need to be removed.

* = Transmitter enable Low.

6.1.24 Secure Hardware Failure

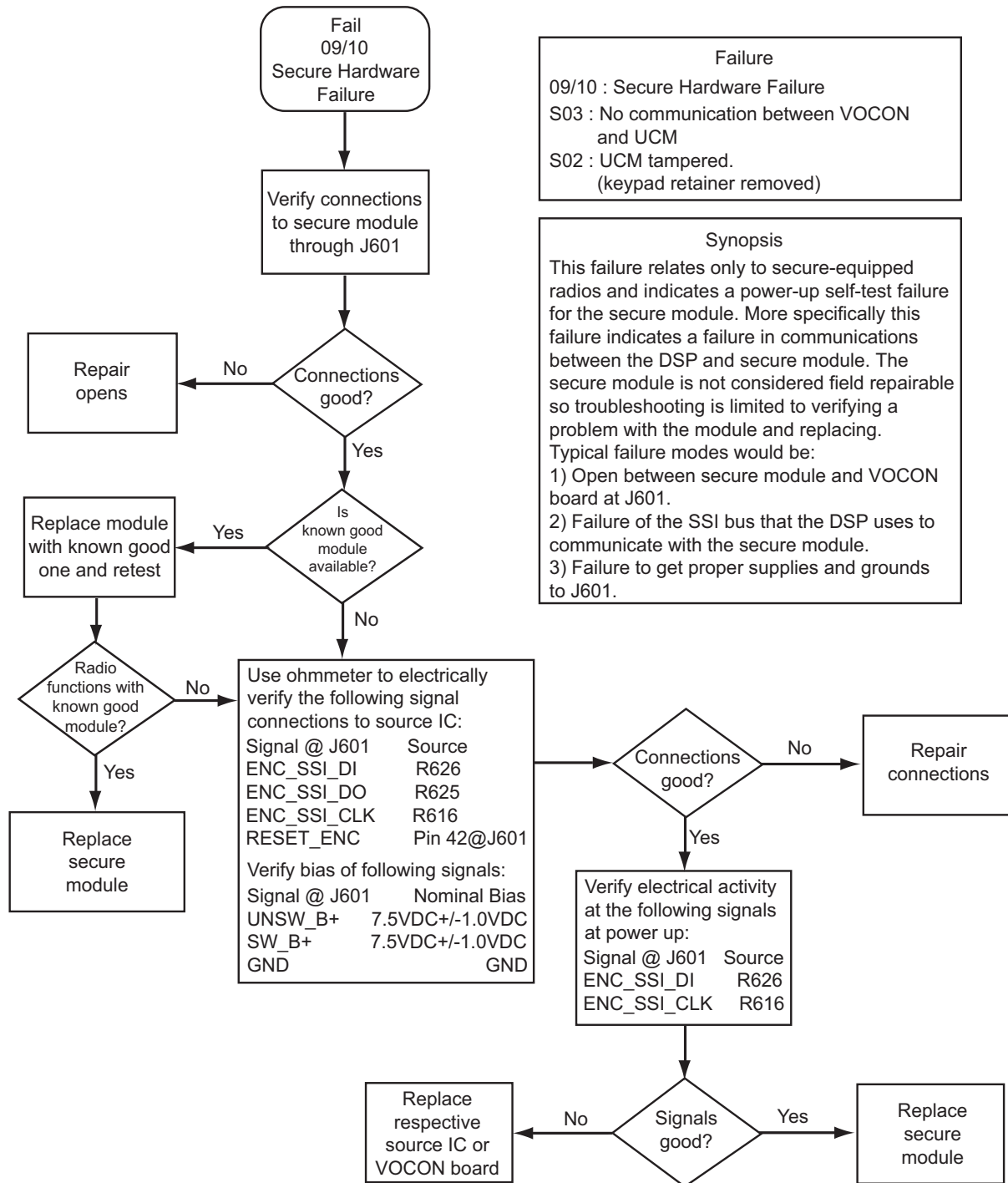

MAEPF-27387-O

Notes

Chapter 6.2 UHF1 Troubleshooting Charts

6.2.1 Introduction

This chapter contains detailed troubleshooting flowcharts. These flowcharts are for use as a guide in determining the problem areas. They are not a substitute for the knowledge of circuit operation and astute troubleshooting techniques. It is advisable to refer to the related detailed circuit descriptions in the theory sections prior to troubleshooting a radio.

This manual is to be used in conjunction with the ASTRO XTS 2500/XTS 2500I Digital Portable Radios Basic Service Manual (Motorola part number 6816984H01), which uses the pass/fail service approach to radio problems.

6.2.2 List of Troubleshooting Flowcharts

Most troubleshooting flowcharts end up by pointing to an IC to replace. **It is not always noted, but it is good practice to verify supplies and grounds to the affected IC and to trace continuity to the malfunctioning signal and related circuitry before replacing any IC.** For instance, if a clock signal is not available at a destination IC, continuity from the source IC should be checked before replacing the source IC.

Table 6.2-1. List of Troubleshooting Flowcharts

Chart Name	Page No.
UHF Range 1 Radio Main Troubleshooting Chart	6.2-2
Radio Power-Up Fail Troubleshooting Chart	6.2-3
DC Supply Fail Troubleshooting Chart	6.2-6
Button Test Troubleshooting Chart	6.2-9
Volume Set Error Troubleshooting Chart	6.2-10
Zone/Channel Select Error Troubleshooting Chart	6.2-11
Top/Side Button Error Troubleshooting Chart	6.2-12
No Display Troubleshooting Chart	6.2-13
UHF Range 1 Receive RF Troubleshooting Chart	6.2-16
VOCON Receive Audio Troubleshooting Chart	6.2-17
UHF Range 1 Frequency Generation Unit Troubleshooting Chart	6.2-18
VOCON Transmit Audio Troubleshooting Chart	6.2-19
No Transmit Deviation Troubleshooting Chart	6.2-21
UHF Range 1 Transmitter RF Troubleshooting Chart	6.2-22
Secure Hardware Failure	6.2-23

NOTE: μ C is used in several of the following troubleshooting charts.
 μ C = microcontroller unit (MCU).

6.2.3 UHF Range 1 Radio Main Troubleshooting Chart

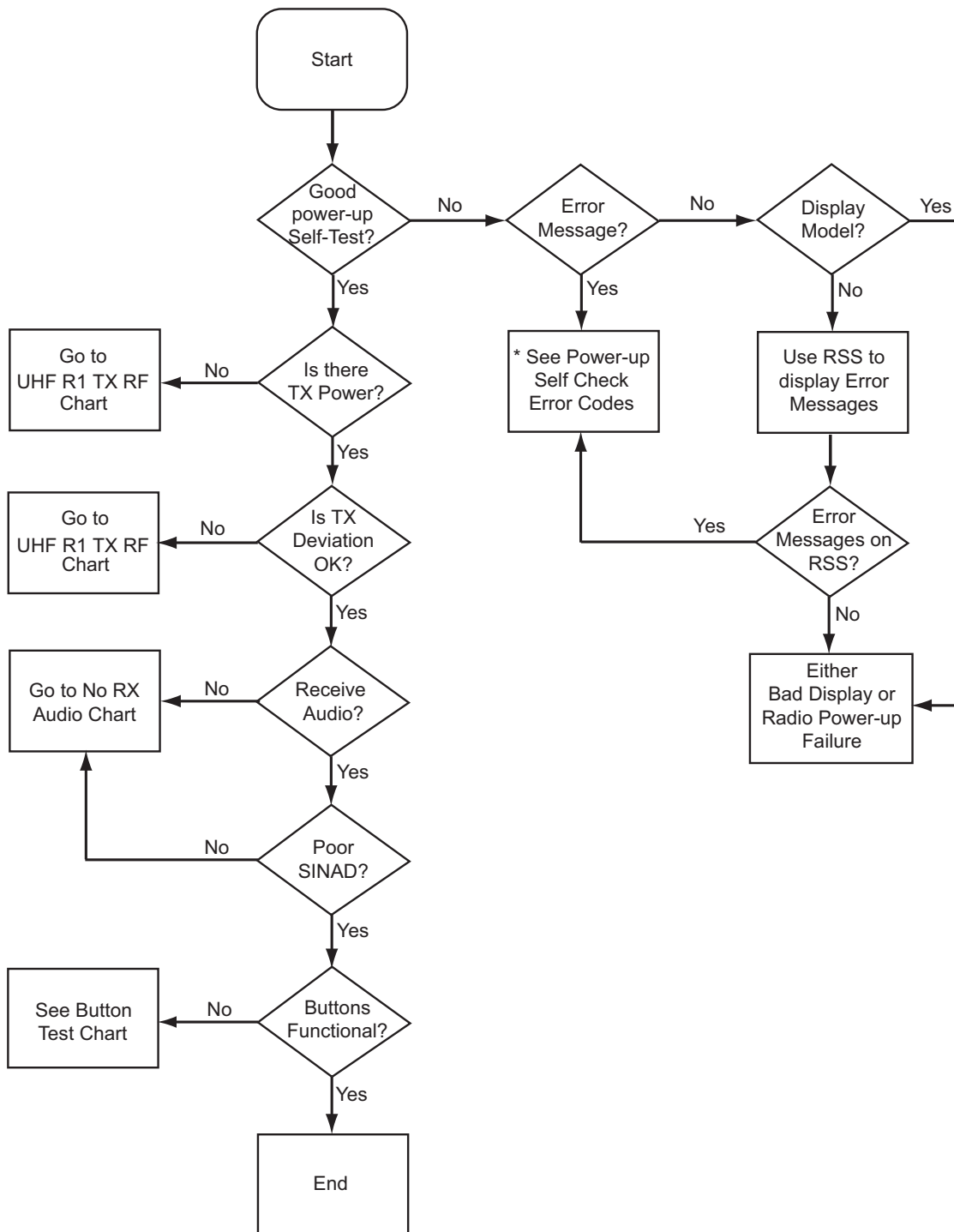

MAEPF-27329-O

*Please see Table 5-2 on page 5-3.

6.2.4 Radio Power-Up Fail Troubleshooting Chart (1 of 3)

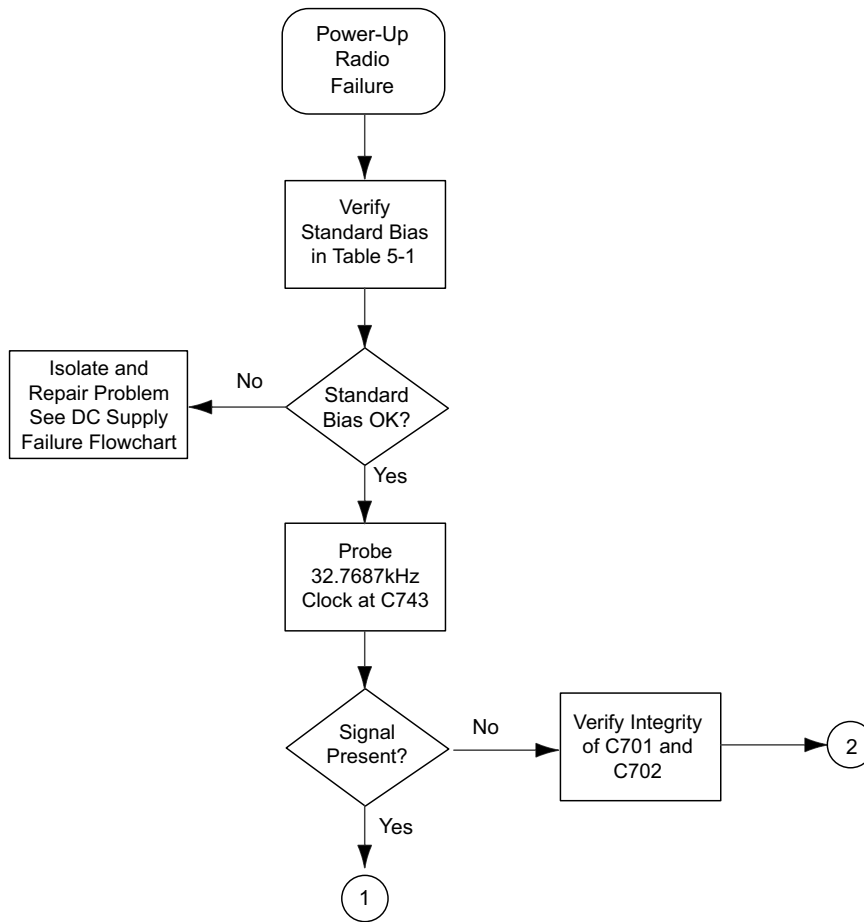

6.2.5 Radio Power-Up Fail Troubleshooting Chart (2 of 3)

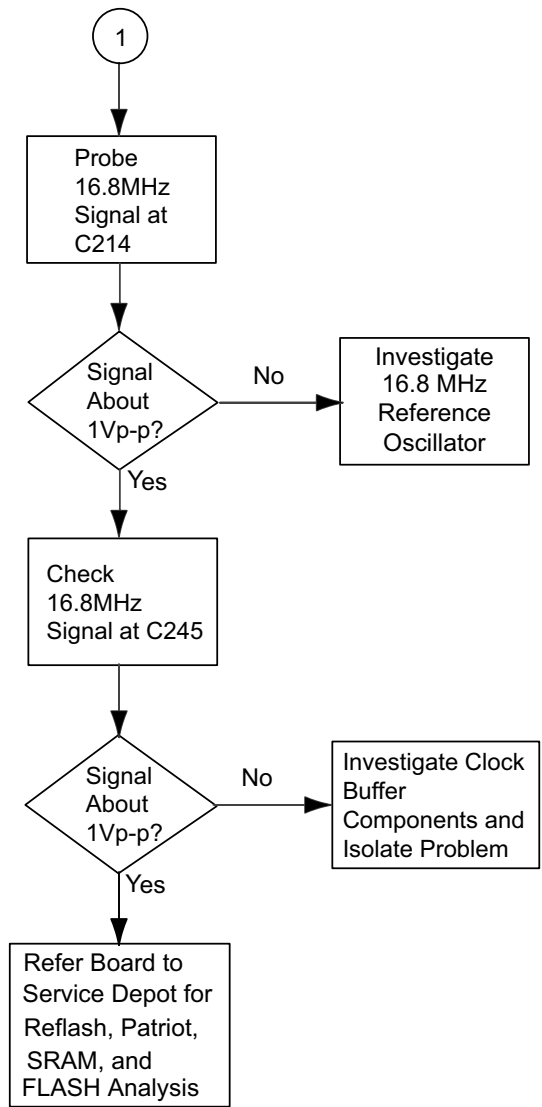

6.2.6 Radio Power-Up Fail Troubleshooting Chart (3 of 3)

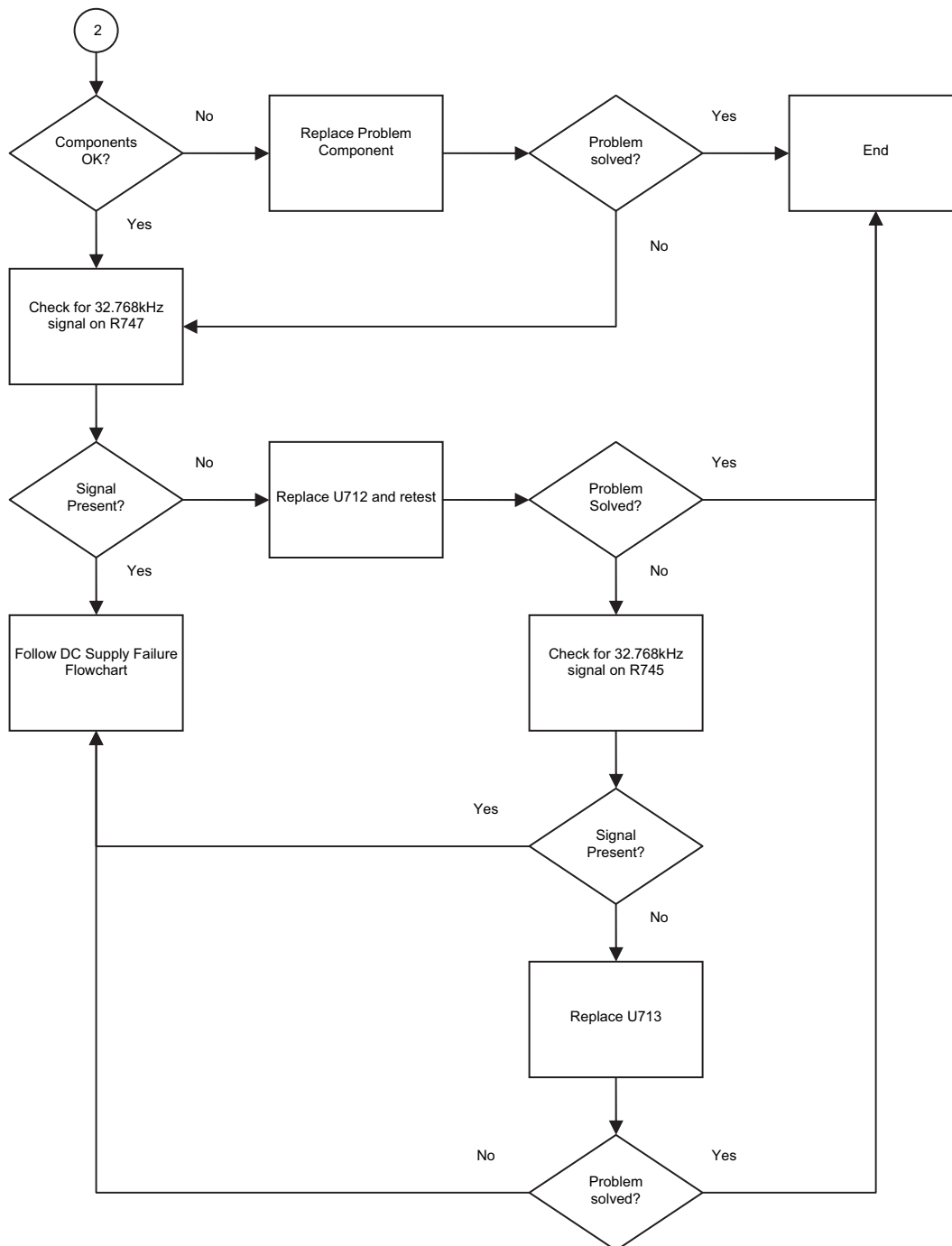

6.2.7 DC Supply Fail Troubleshooting Chart (1 of 3)

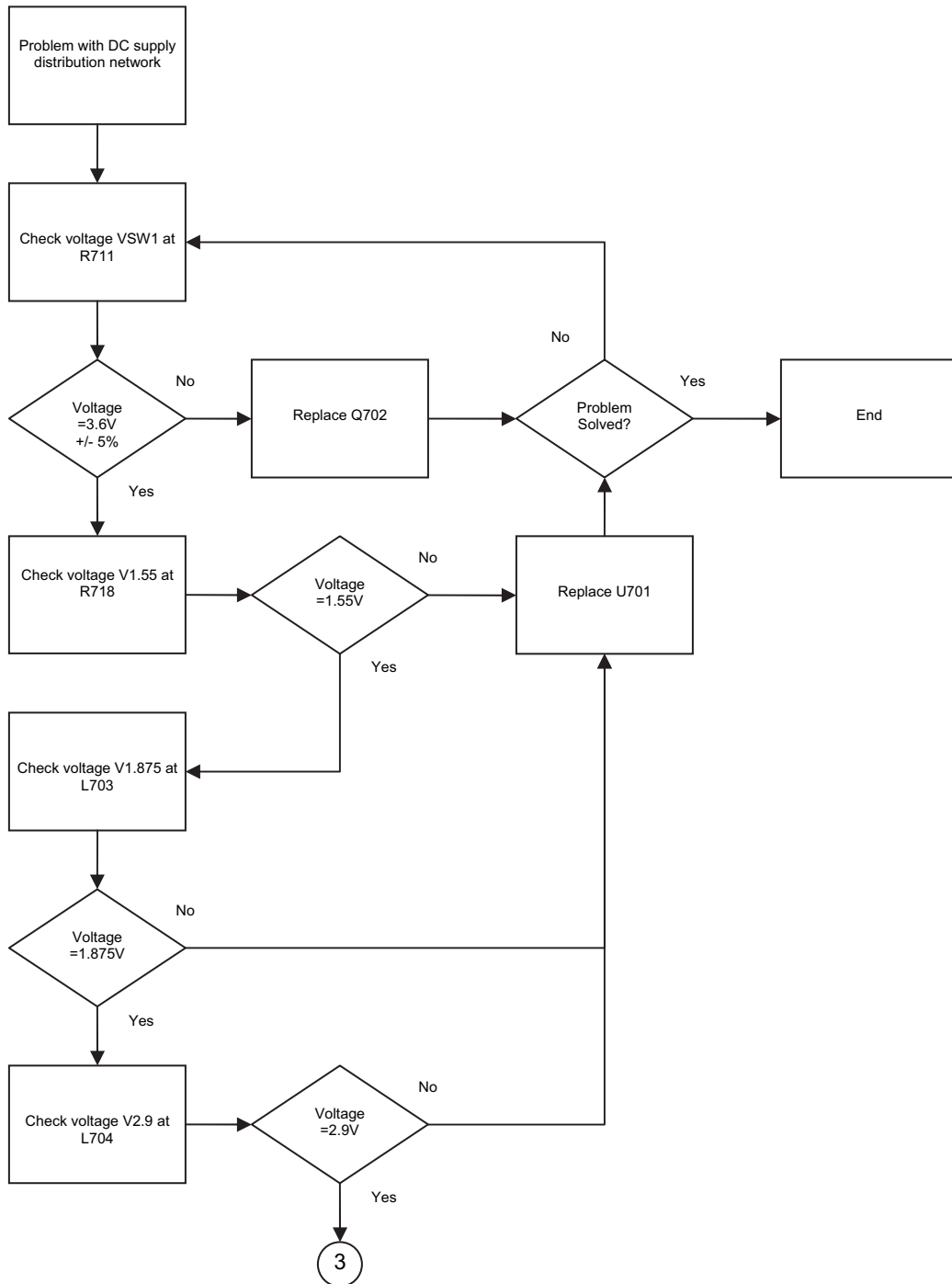

6.2.8 DC Supply Fail Troubleshooting Chart (2 of 3)

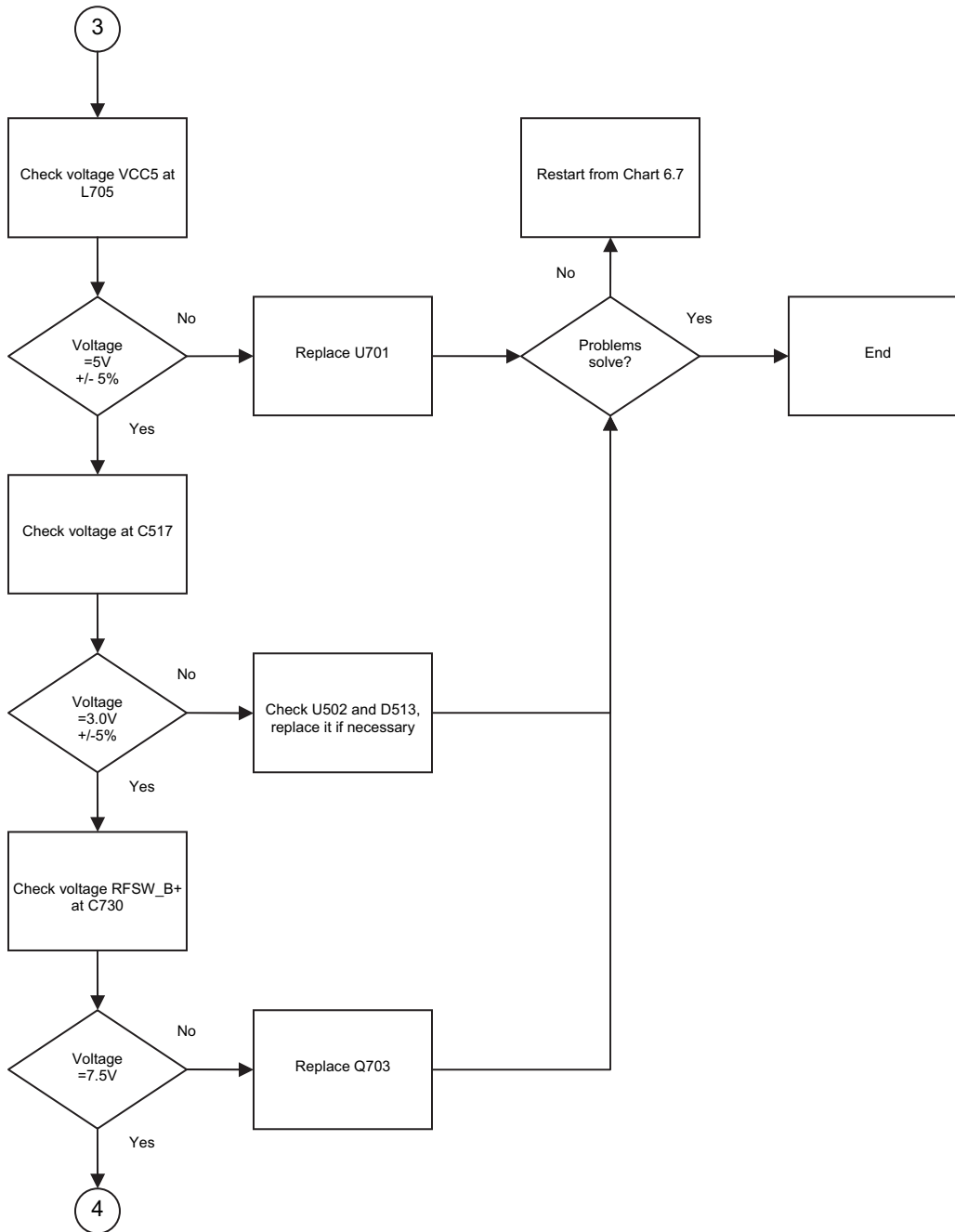

6.2.9 DC Supply Fail Troubleshooting Chart (3 of 3)

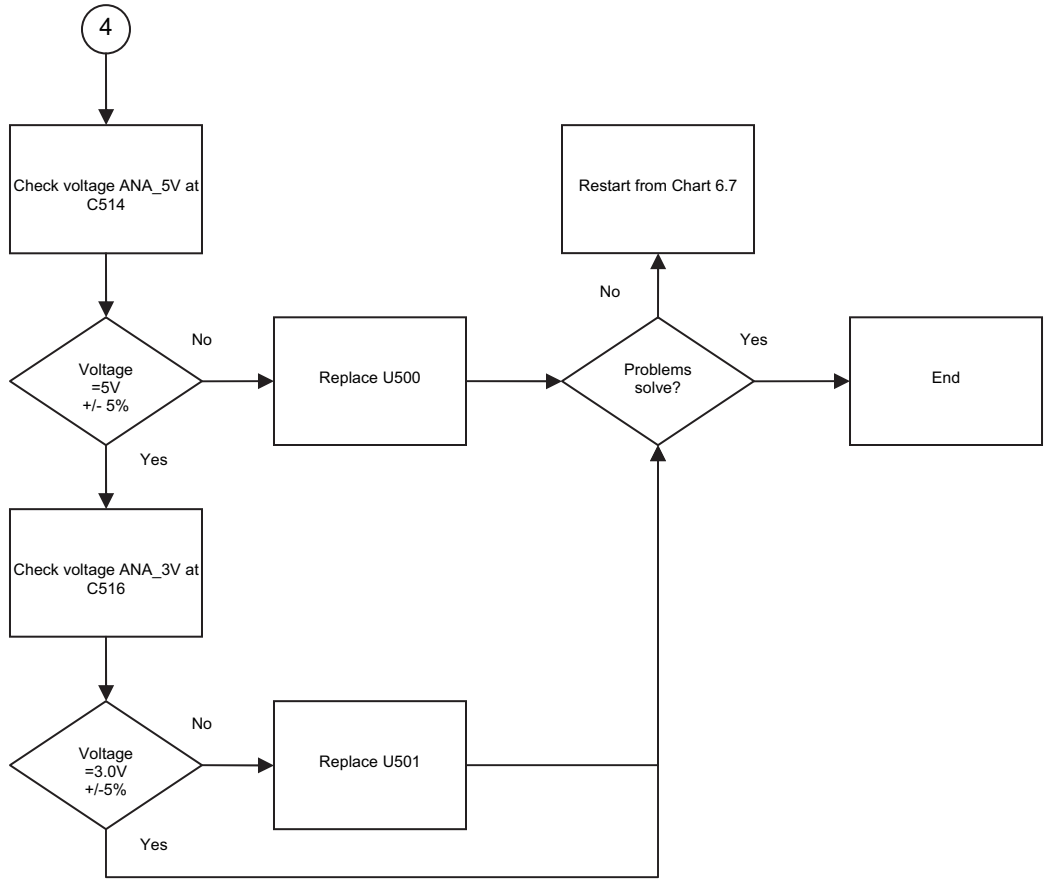

6.2.10 Button Test Troubleshooting Chart

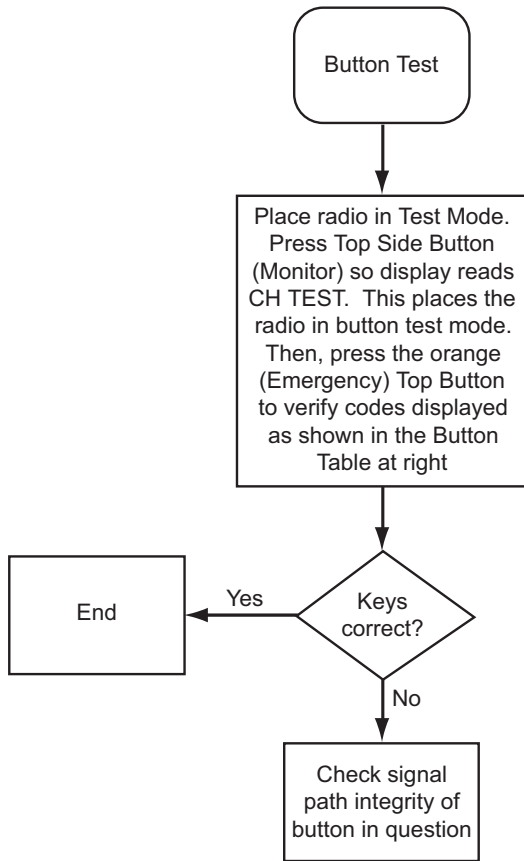

Synopsis

This chart relates to a failure in the button functions. Basic Failure modes are as follows:

- 1) Failure in keypad flex assembly.
- 2) Bad Connection
- 3) Defective Switches or pads
- 4) Defective MAKO IC (U701)

Button Table

Button	Code	Chart
PTT	1/ 0-1	
Top Button (Emergency)	3/ 0-1	C.6
Side Button 1 (Monitor)	96/ 0-1	C.6
Side Button 2	97/ 0-1	C.6
Side Button 3	98/ 0-1	C.6
Channel Select (Frequency)	4/ 0-15	C.8
Volume Control Knob	0/ 0-220	C.7
Zone Select	65/ 0-2	C.8

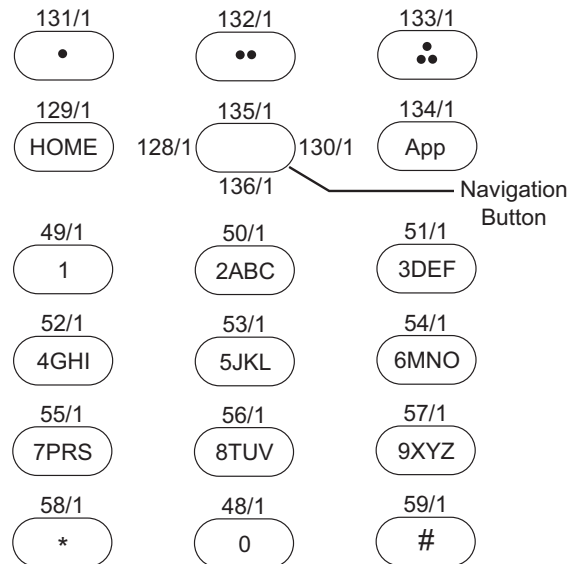

MAEPF-27335-O

6.2.11 Volume Set Error Troubleshooting Chart

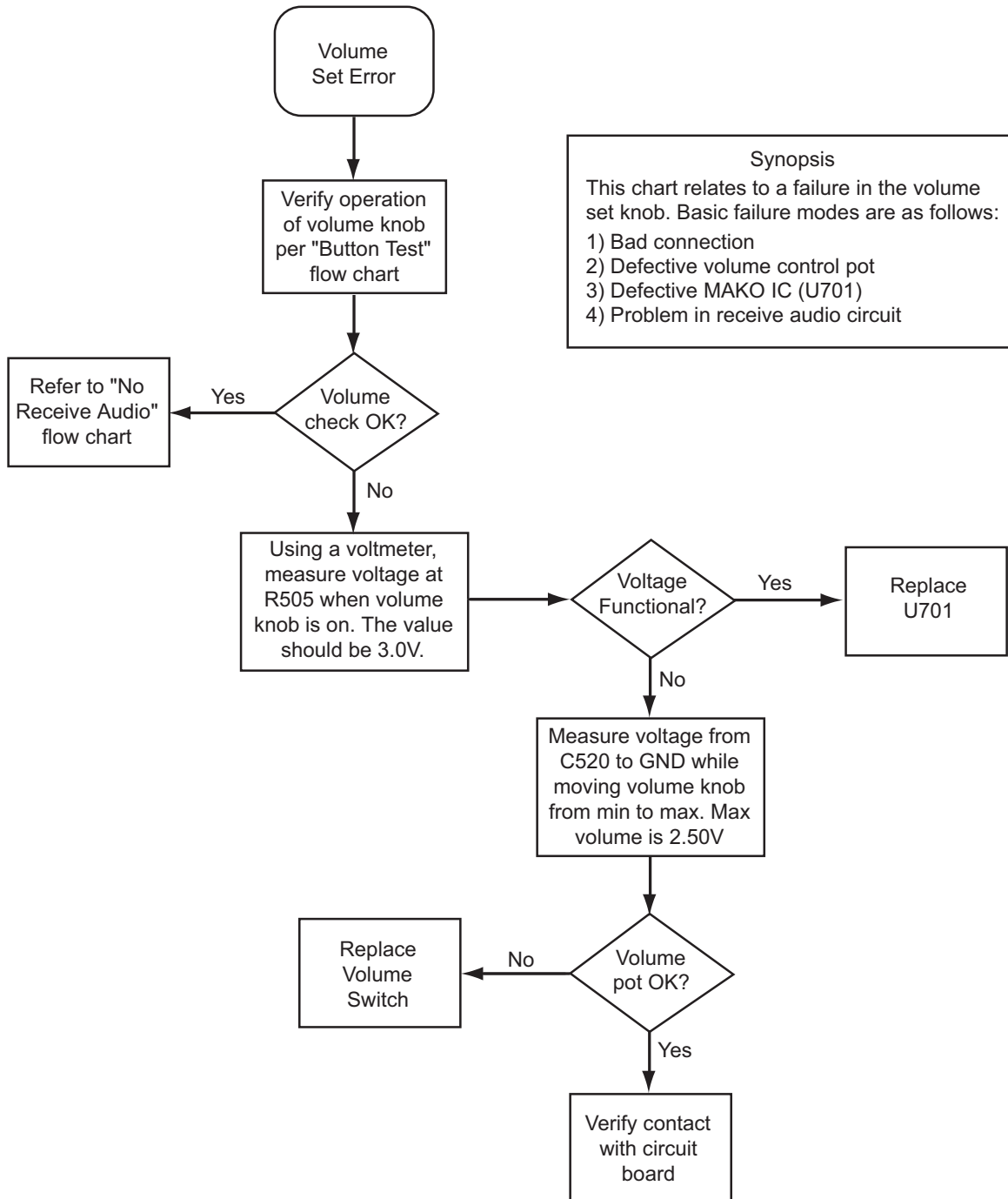

Synopsis
 This chart relates to a failure in the volume set knob. Basic failure modes are as follows:
 1) Bad connection
 2) Defective volume control pot
 3) Defective MAKO IC (U701)
 4) Problem in receive audio circuit

MAEPF-27336-O

6.2.12 Zone/Channel Select Error Troubleshooting Chart

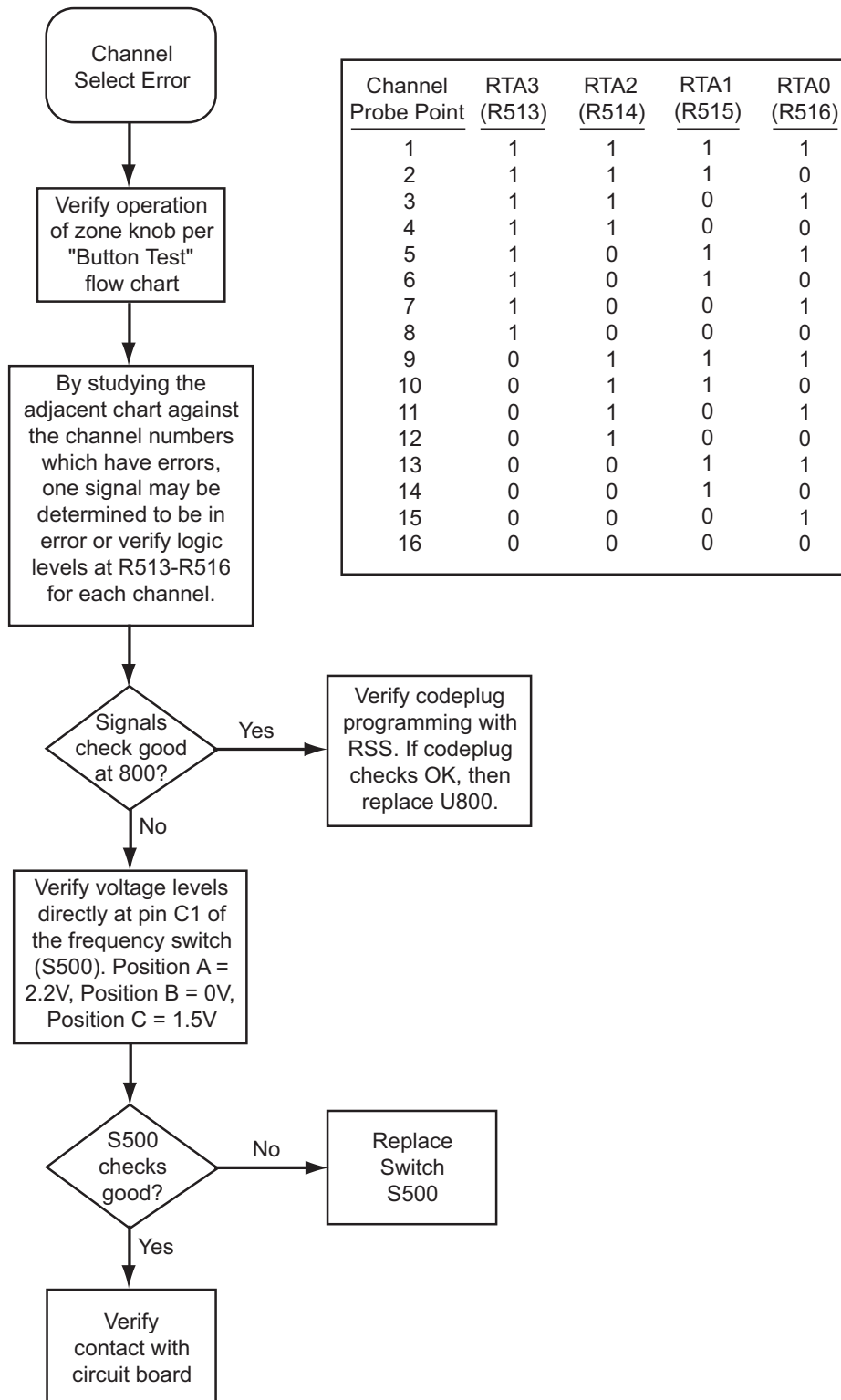

MAEPF-27337-O

6.2.13 Top/Side Button Error Troubleshooting Chart

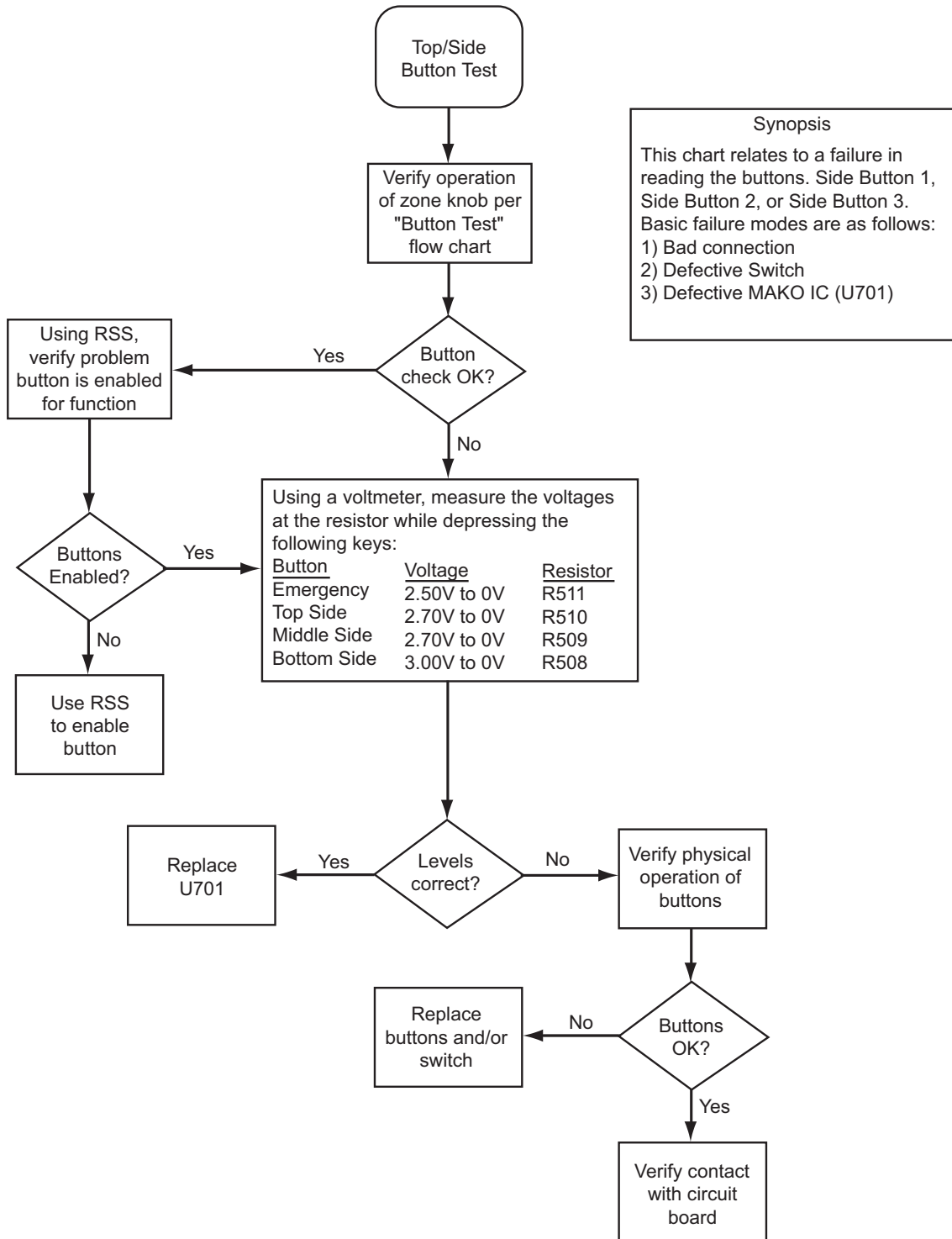

MAEPF-27338-O

6.2.14 No Display Troubleshooting Chart (1 of 3)

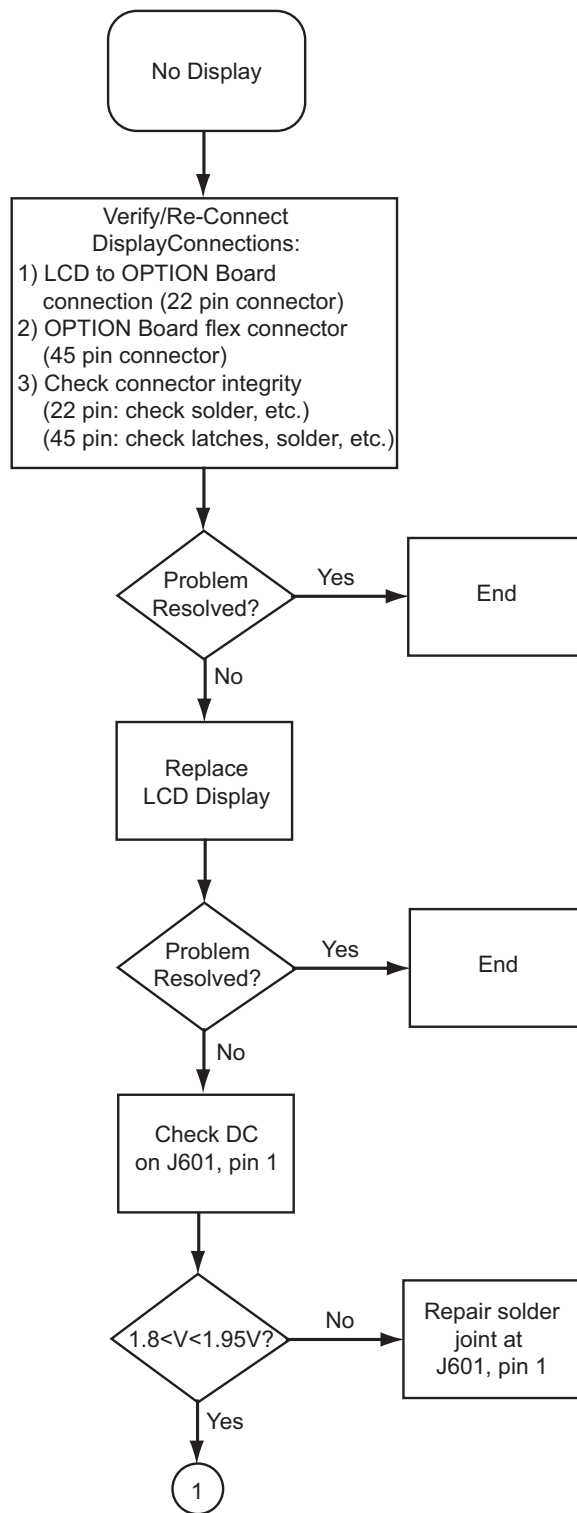

MAEPF-27339-O

6.2.15 No Display Troubleshooting Chart (2 of 3)

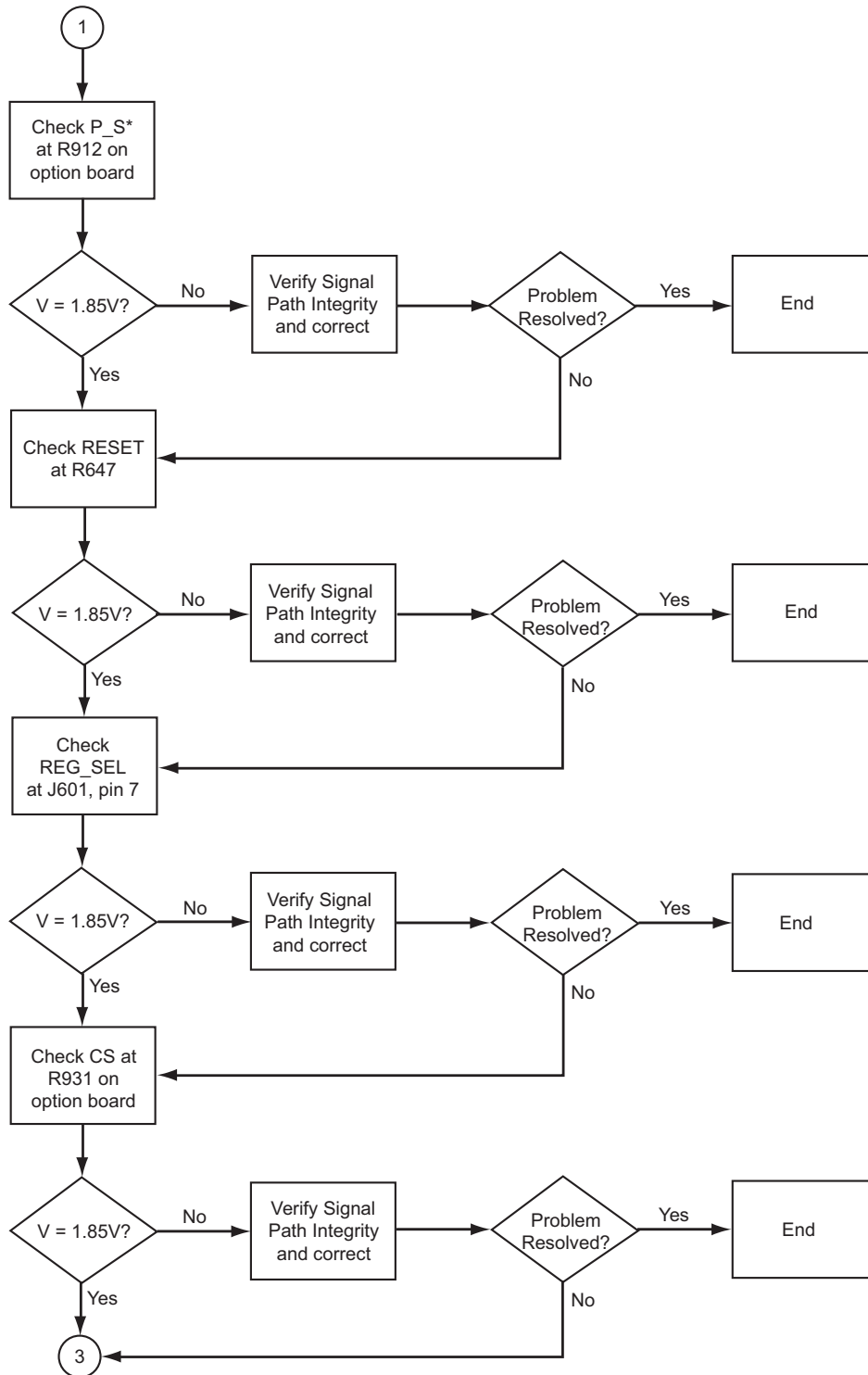

MAEPF-27340-O

6.2.16 No Display Troubleshooting Chart (3 of 3)

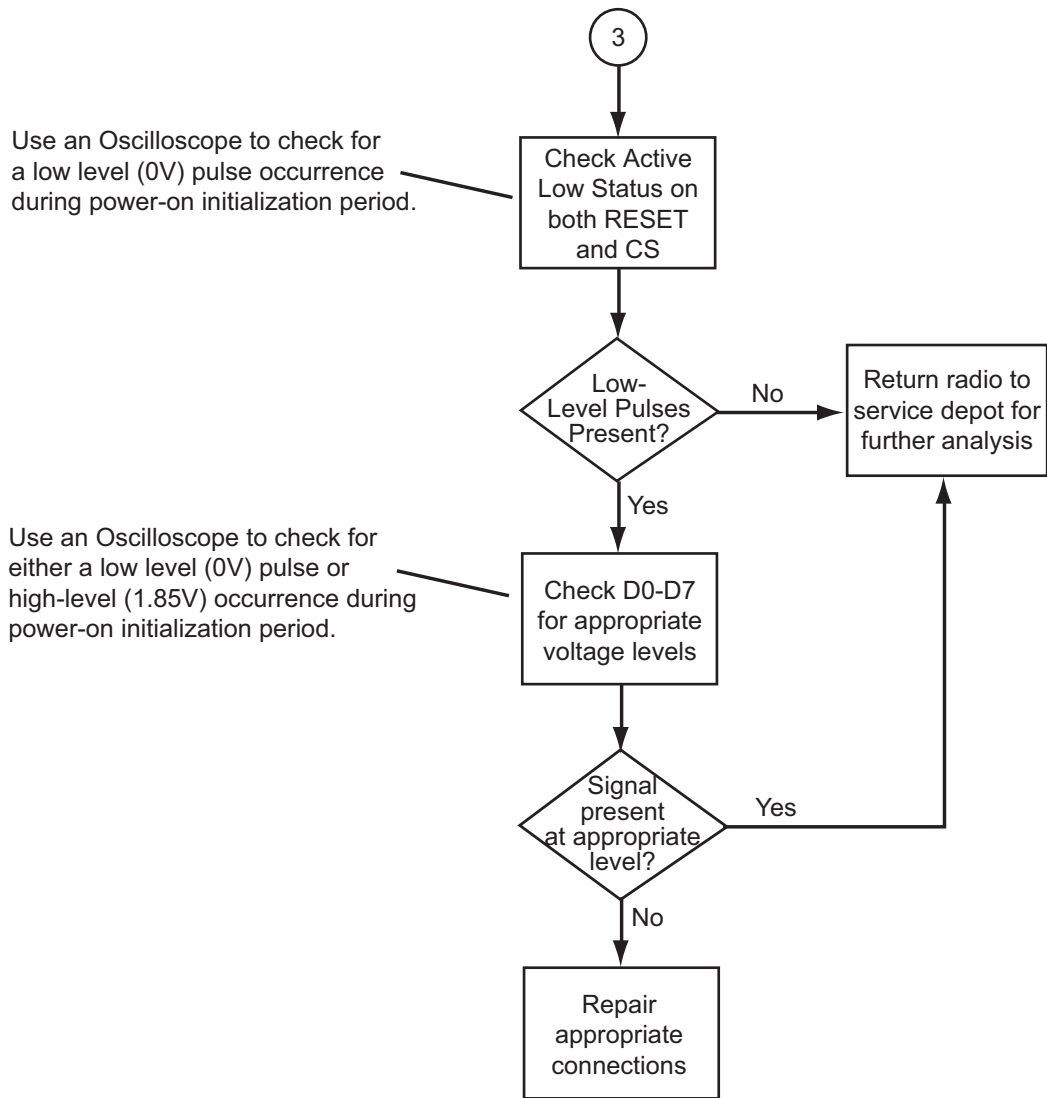

MAEPF-27341-O

6.2.17 UHF Range 1 Receive RF Troubleshooting Chart

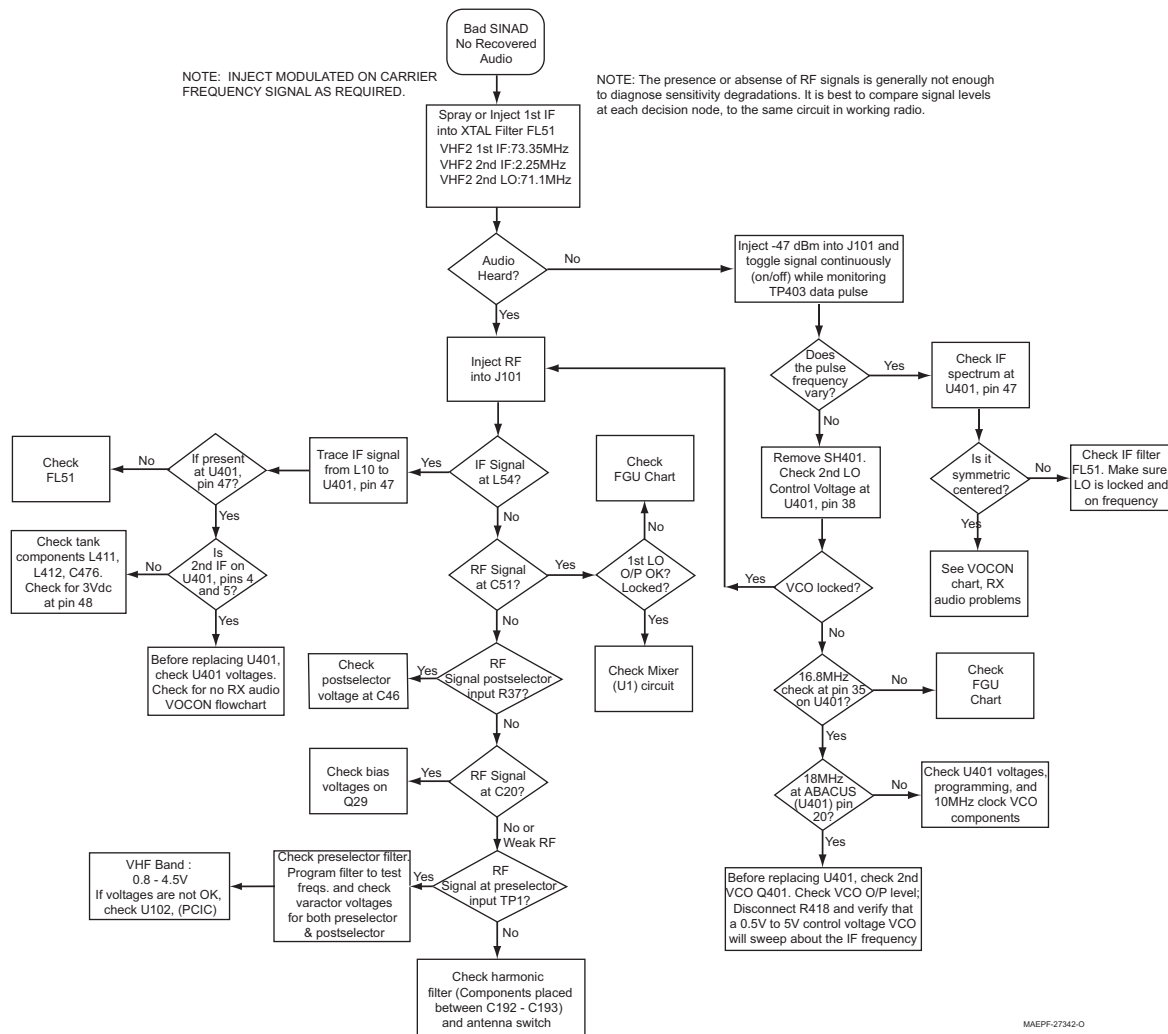

MAEPF-27342-0

6.2.18 VOCON Receive Audio Troubleshooting Chart

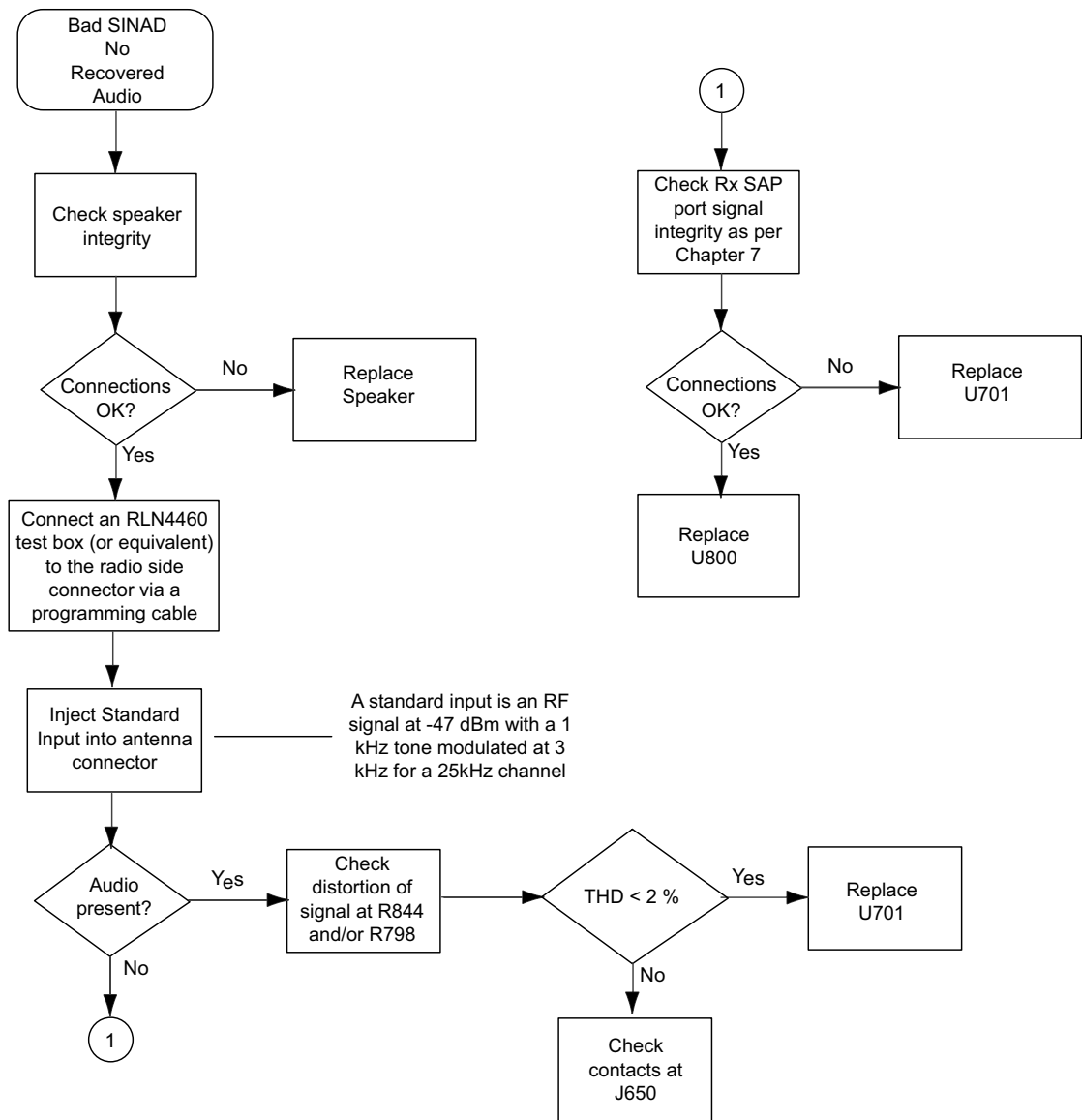

MAEPF-27347-O

6.2.19 UHF Range 1 Frequency Generation Unit Troubleshooting Chart

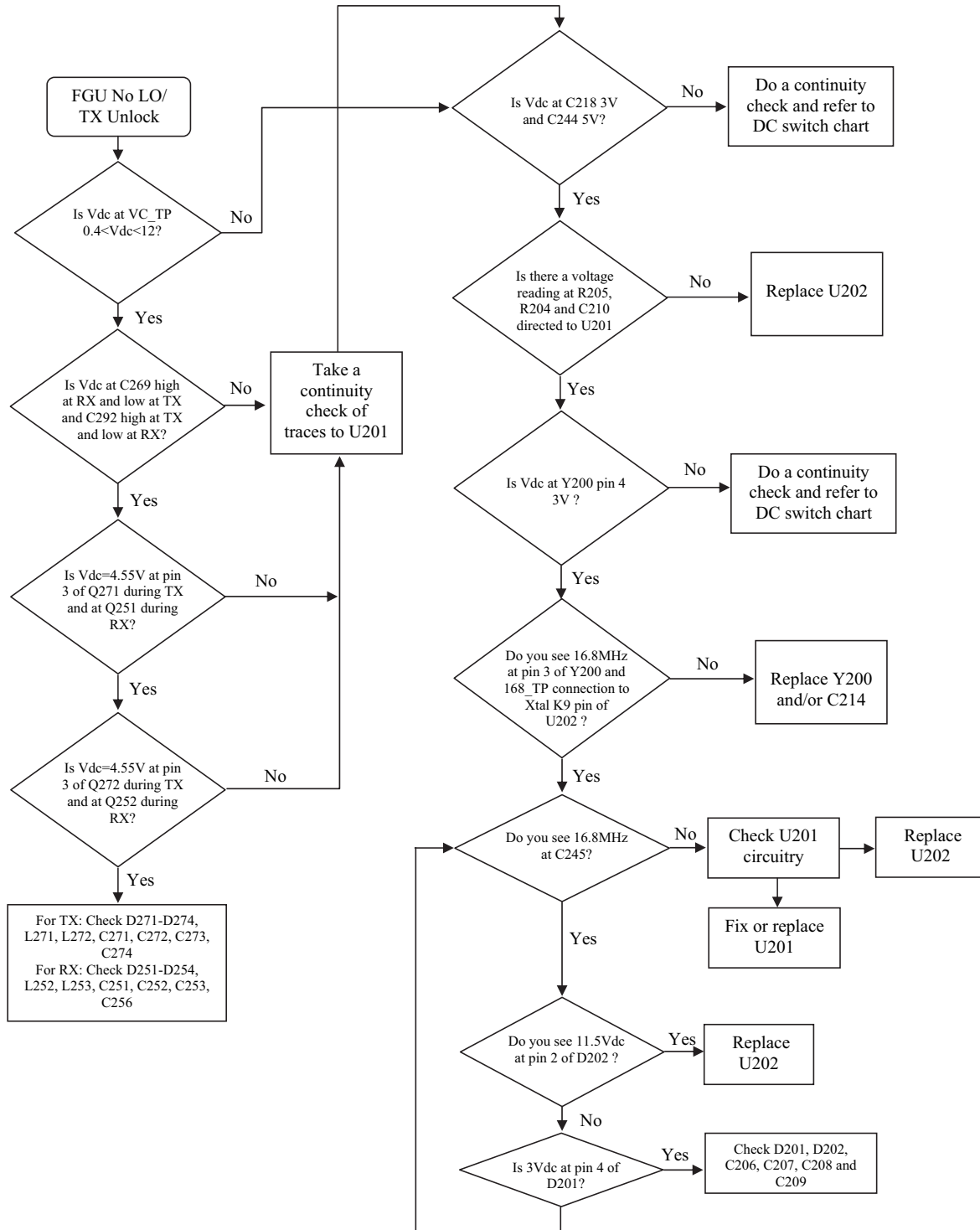

6.2.20 VOCON Transmit Audio Troubleshooting Chart (1 of 2)

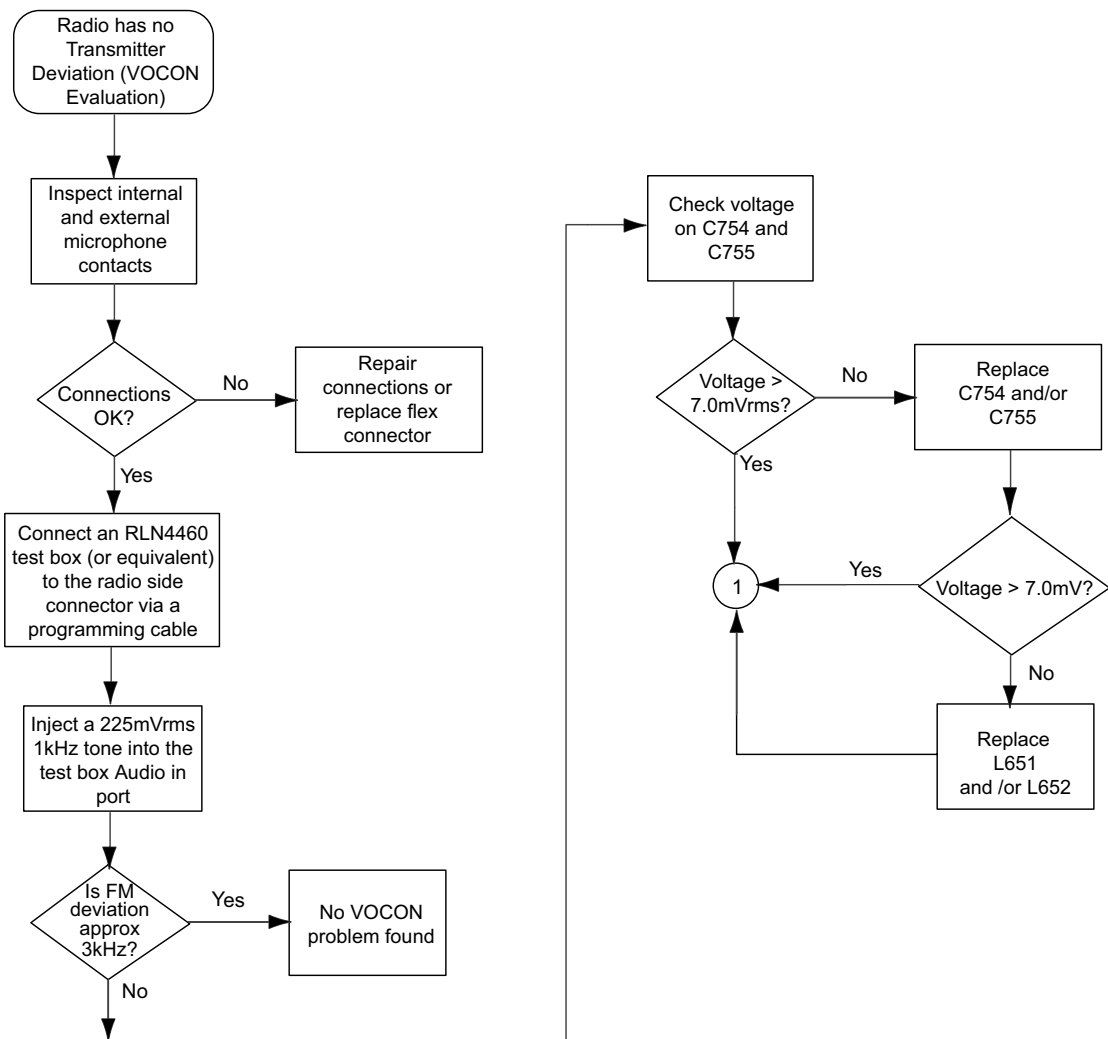

MAEPF-27347-O

6.2.21 VOCON Transmit Audio Troubleshooting Chart (2 of 2)

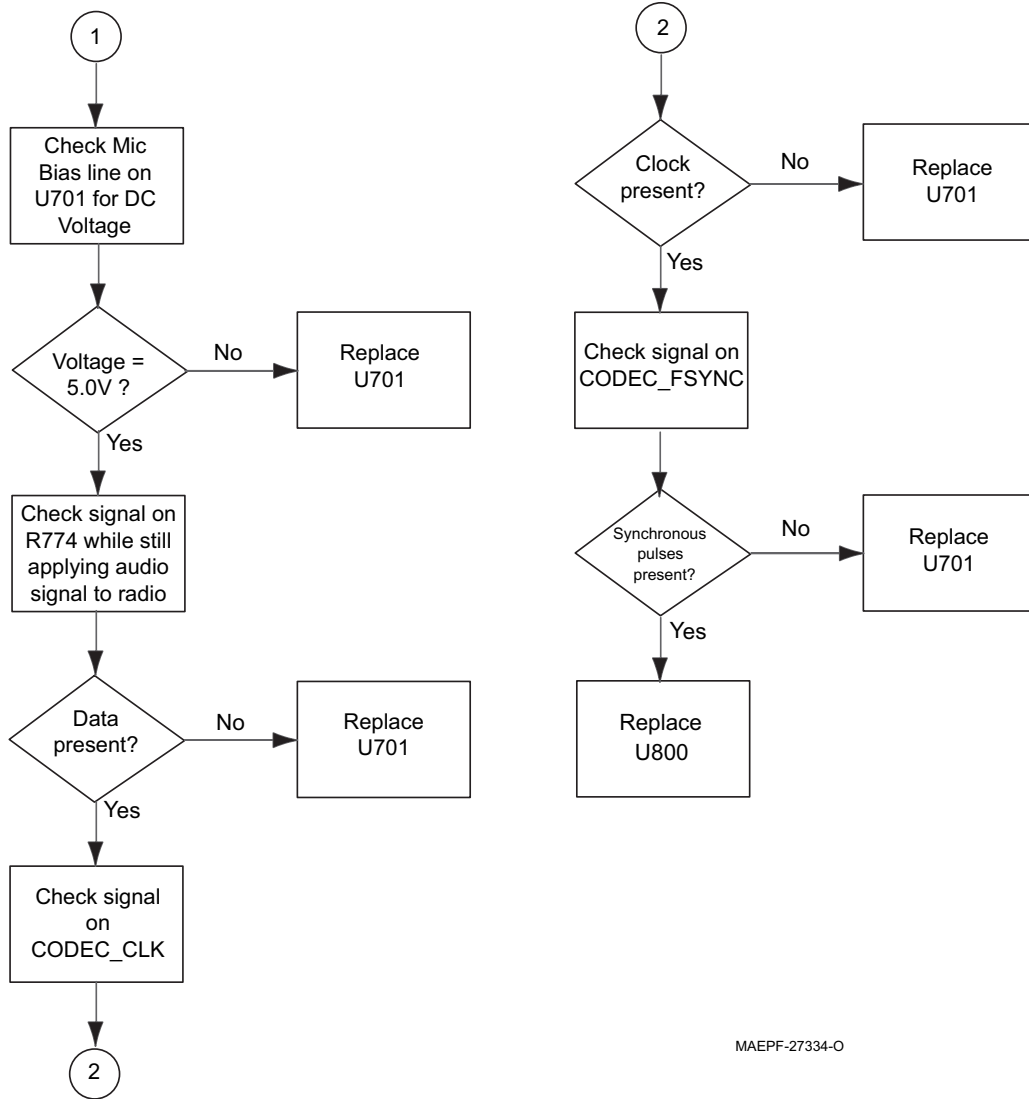

MAEPF-27334-O

6.2.22 No Transmit Deviation Troubleshooting Chart

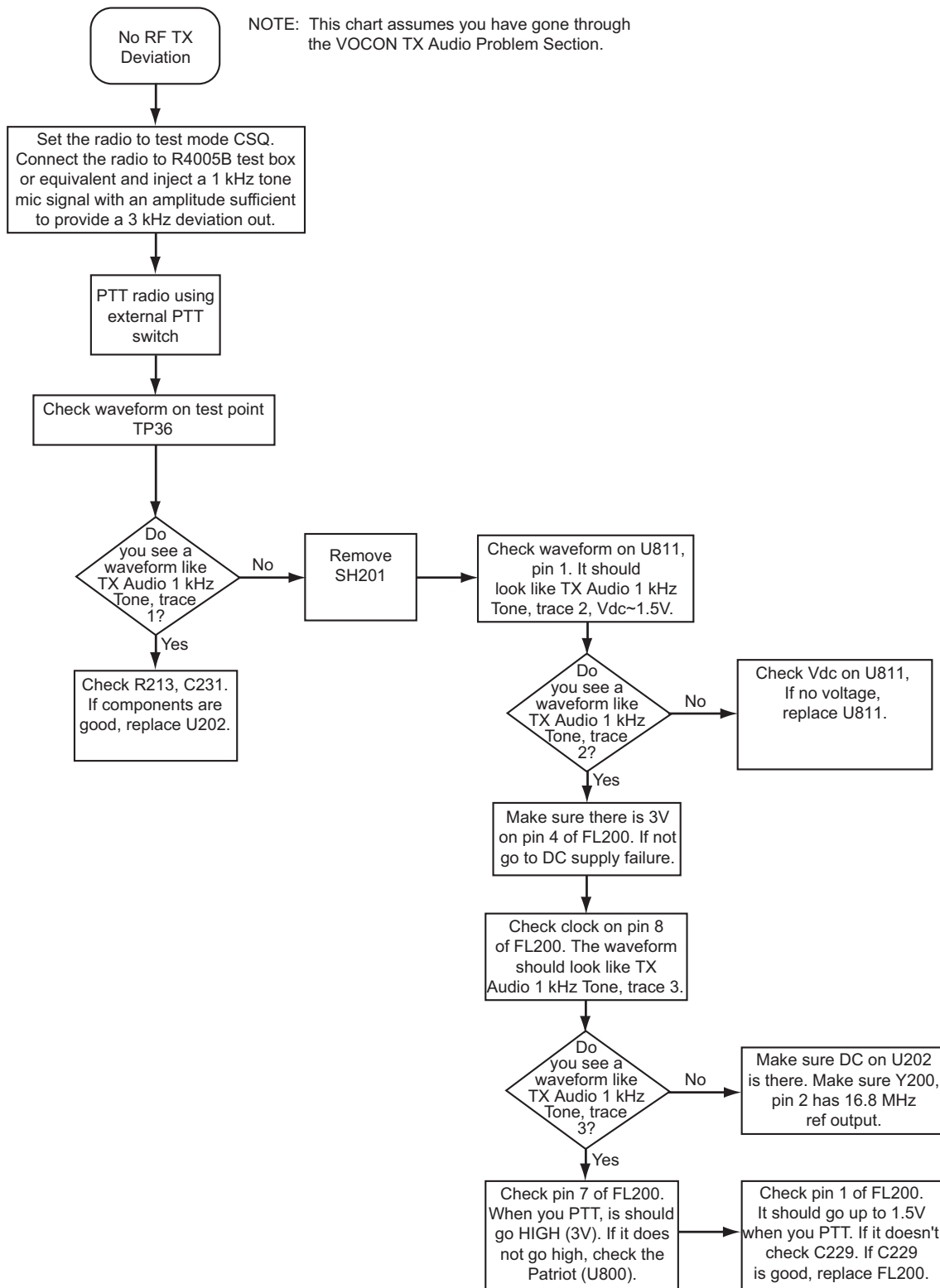

MAEPF-27343-O

6.2.23 UHF Range 1 Transmitter RF Troubleshooting Chart

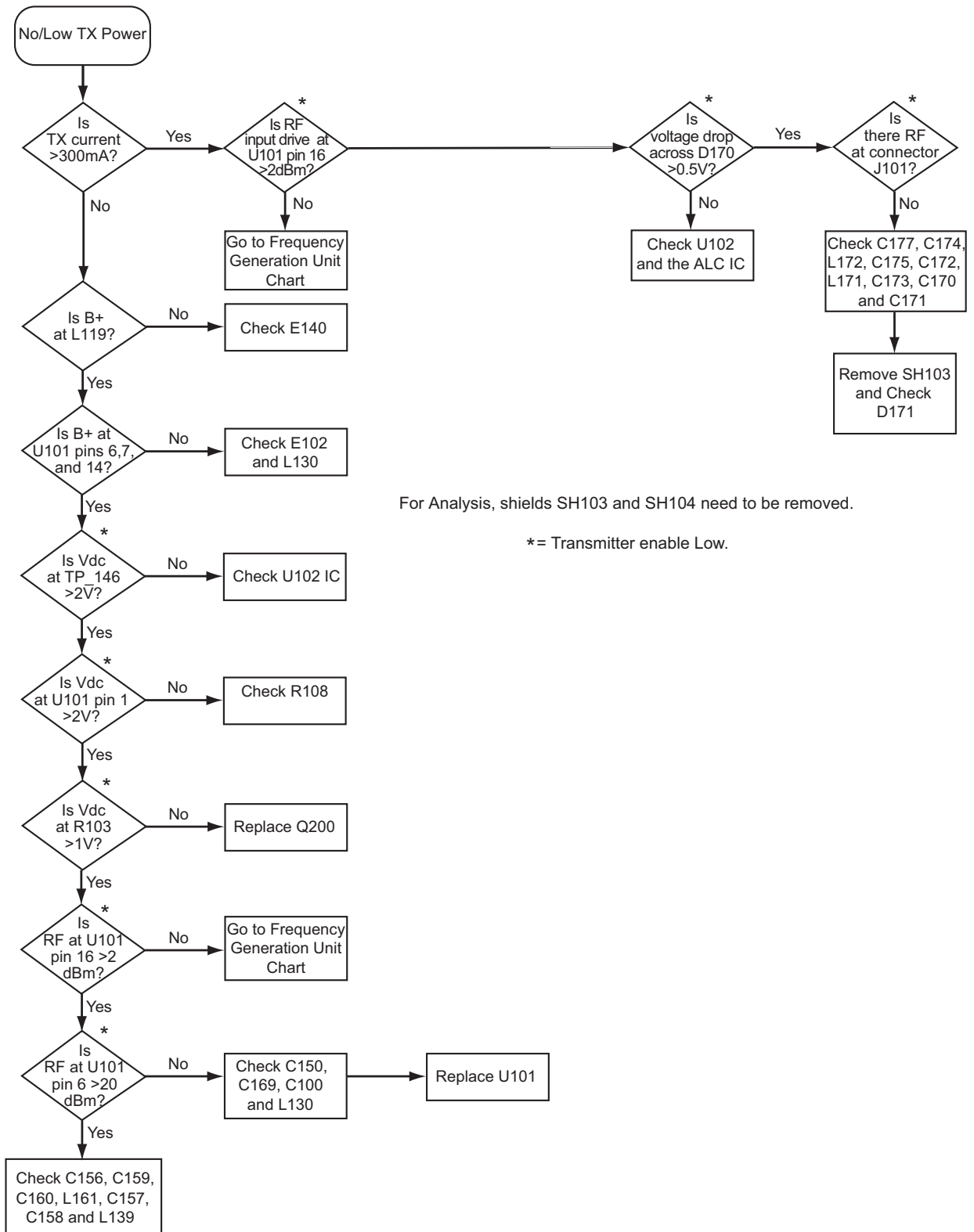

For Analysis, shields SH103 and SH104 need to be removed.

*= Transmitter enable Low.

6.2.24 Secure Hardware Failure

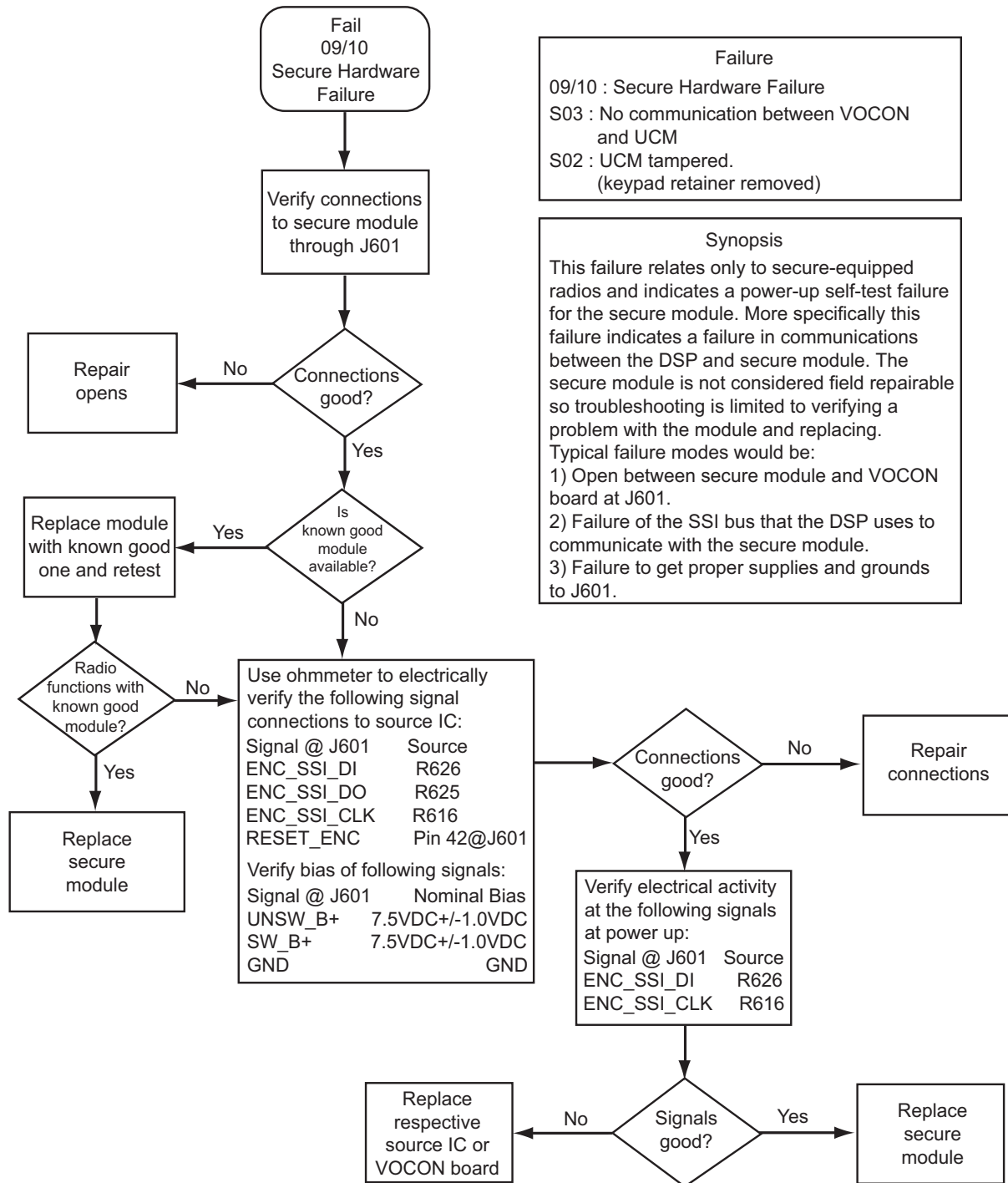

MAEPF-27387-O

Notes

Chapter 6.3 UHF2 Troubleshooting Charts

6.3.1 Introduction

This chapter contains detailed troubleshooting flowcharts. These flowcharts are for use as a guide in determining the problem areas. They are not a substitute for the knowledge of circuit operation and astute troubleshooting techniques. It is advisable to refer to the related detailed circuit descriptions in the theory sections prior to troubleshooting a radio.

This manual is to be used in conjunction with the ASTRO XTS 2500/XTS 2500I Digital Portable Radios Basic Service Manual (Motorola part number 6816984H01), which uses the pass/fail service approach to radio problems.

6.3.2 List of Troubleshooting Flowcharts

Most troubleshooting flowcharts end up by pointing to an IC to replace. **It is not always noted, but it is good practice to verify supplies and grounds to the affected IC and to trace continuity to the malfunctioning signal and related circuitry before replacing any IC.** For instance, if a clock signal is not available at a destination IC, continuity from the source IC should be checked before replacing the source IC.

Table 6.3-1. List of Troubleshooting Flowcharts

Chart Name	Page No.
UHF Range 2 Radio Main Troubleshooting Chart	6.3-2
Radio Power-Up Fail Troubleshooting Chart	6.3-3
DC Supply Fail Troubleshooting Chart	6.3-6
Button Test Troubleshooting Chart	6.3-9
Volume Set Error Troubleshooting Chart	6.3-10
Zone/Channel Select Error Troubleshooting Chart	6.3-11
Top/Side Button Error Troubleshooting Chart	6.3-12
No Display Troubleshooting Chart	6.3-13
UHF Range 2 Receive RF Troubleshooting Chart	6.3-16
VOCON Receive Audio Troubleshooting Chart	6.3-17
UHF Range 2 Frequency Generation Unit Troubleshooting Chart	6.3-18
VOCON Transmit Audio Troubleshooting Chart	6.3-19
No Transmit Deviation Troubleshooting Chart	6.3-21
UHF Range 2 Transmitter RF Troubleshooting Chart	6.3-22
Secure Hardware Failure	6.3-23

NOTE: μC is used in several of the following troubleshooting charts.
 μC = microcontroller unit (MCU).

6.3.3 UHF Range 2 Radio Main Troubleshooting Chart

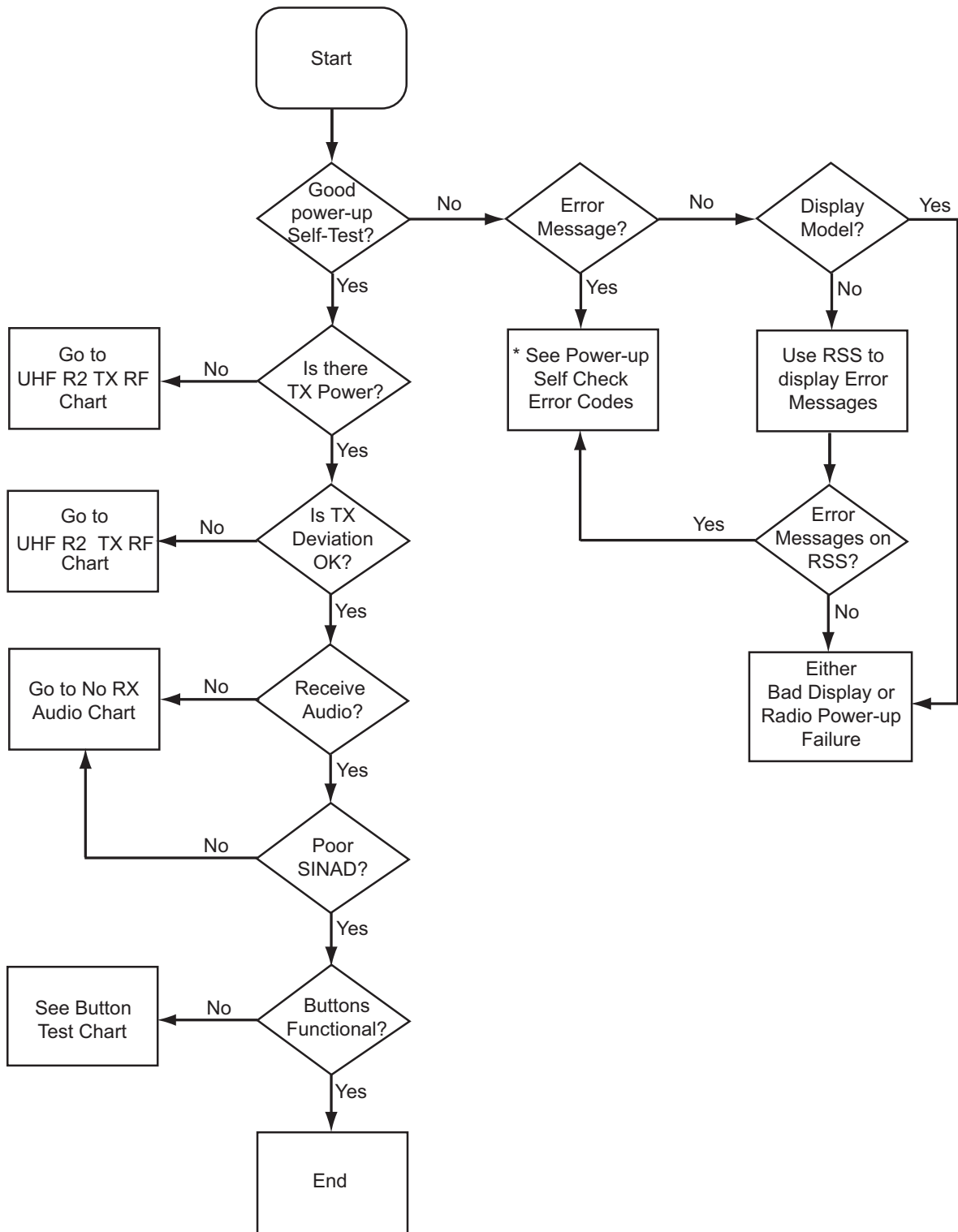

*Please see Table 5-2 on page 5-3.

6.3.4 Radio Power-Up Fail Troubleshooting Chart (1 of 3)

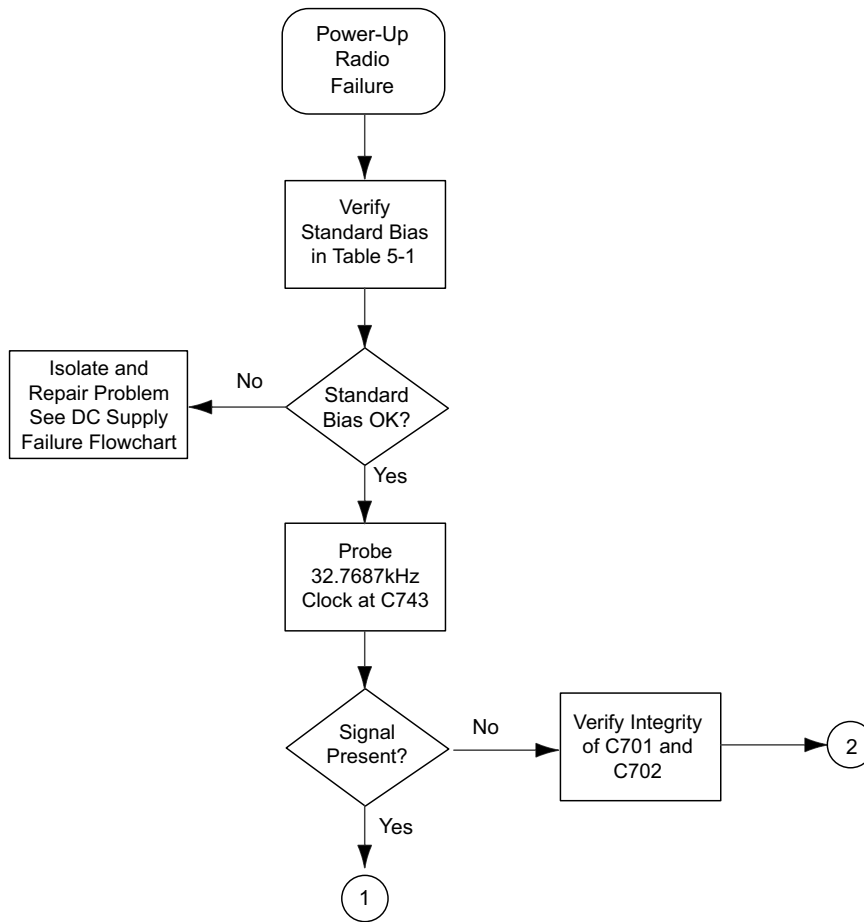

6.3.5 Radio Power-Up Fail Troubleshooting Chart (2 of 3)

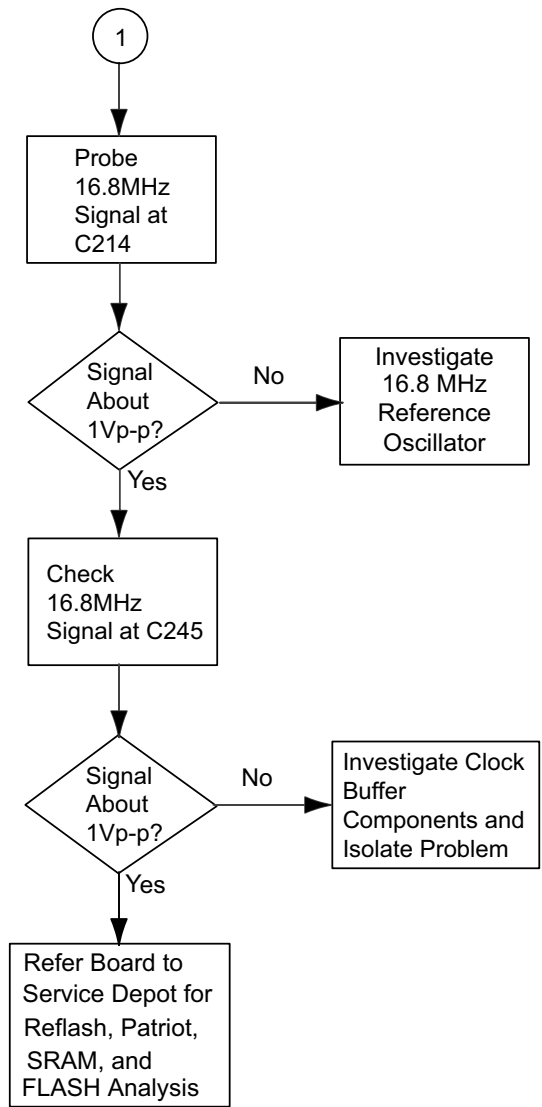

6.3.6 Radio Power-Up Fail Troubleshooting Chart (3 of 3)

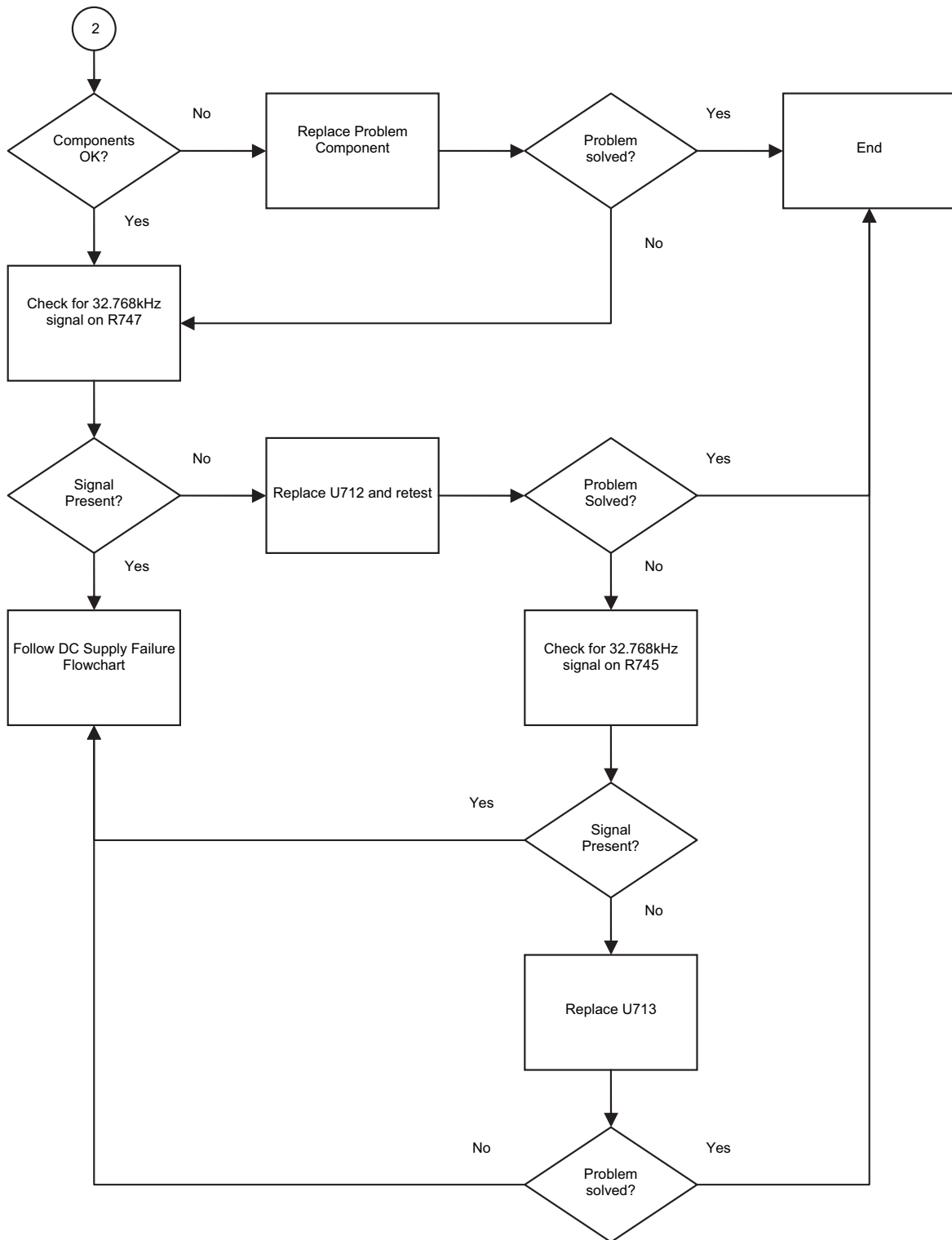

6.3.7 DC Supply Fail Troubleshooting Chart (1 of 3)

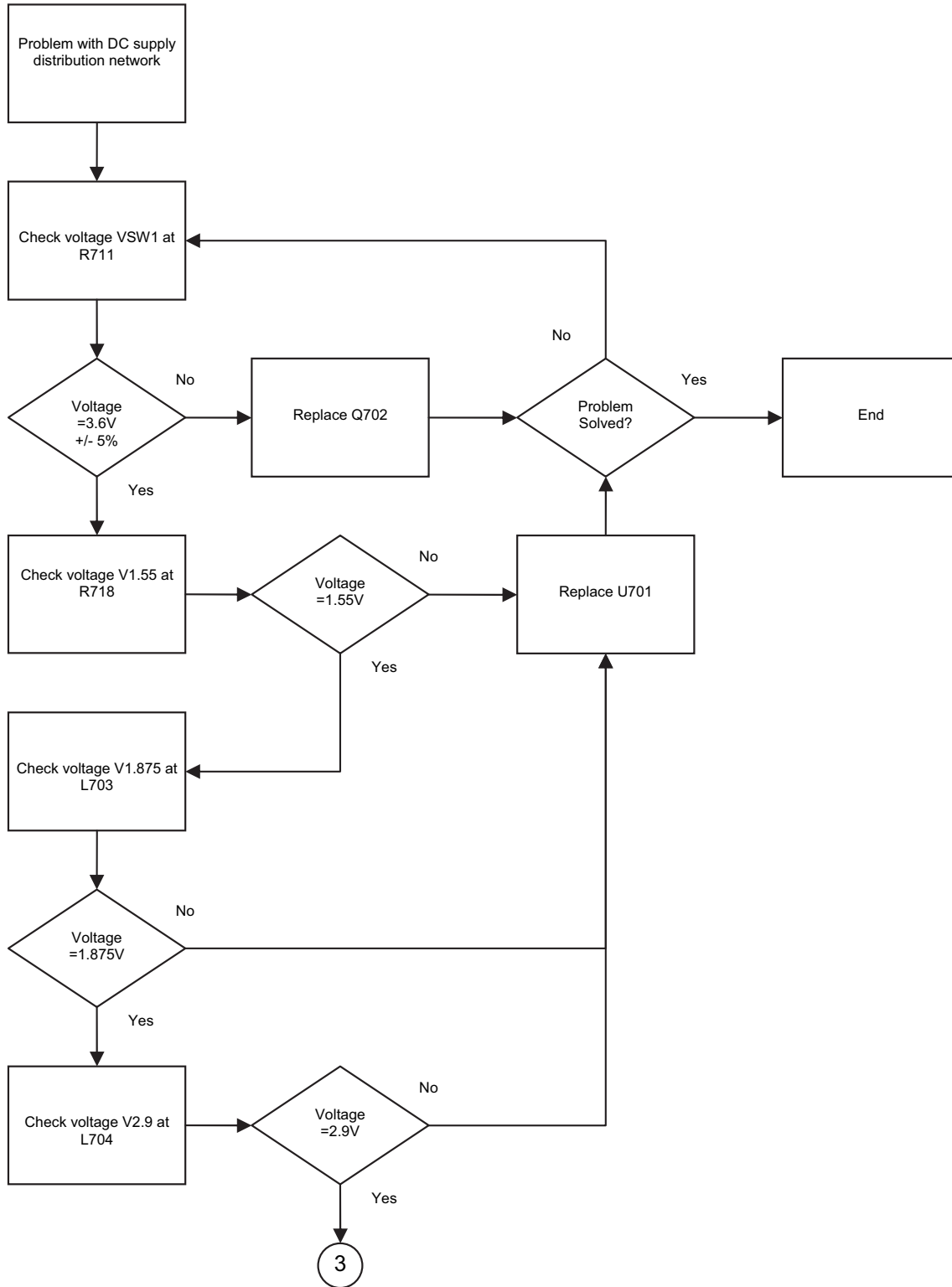

6.3.8 DC Supply Fail Troubleshooting Chart (2 of 3)

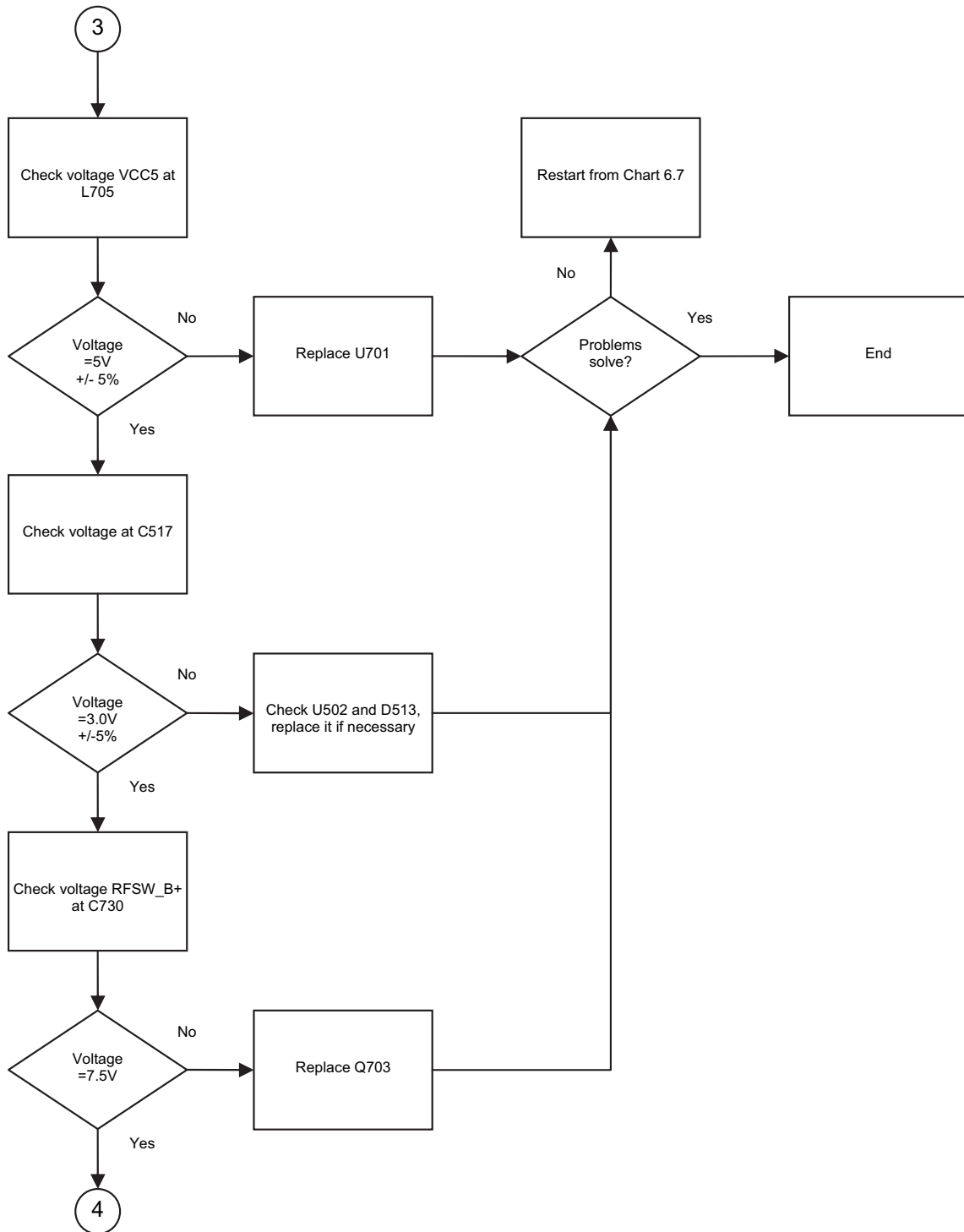

6.3.9 DC Supply Fail Troubleshooting Chart (3 of 3)

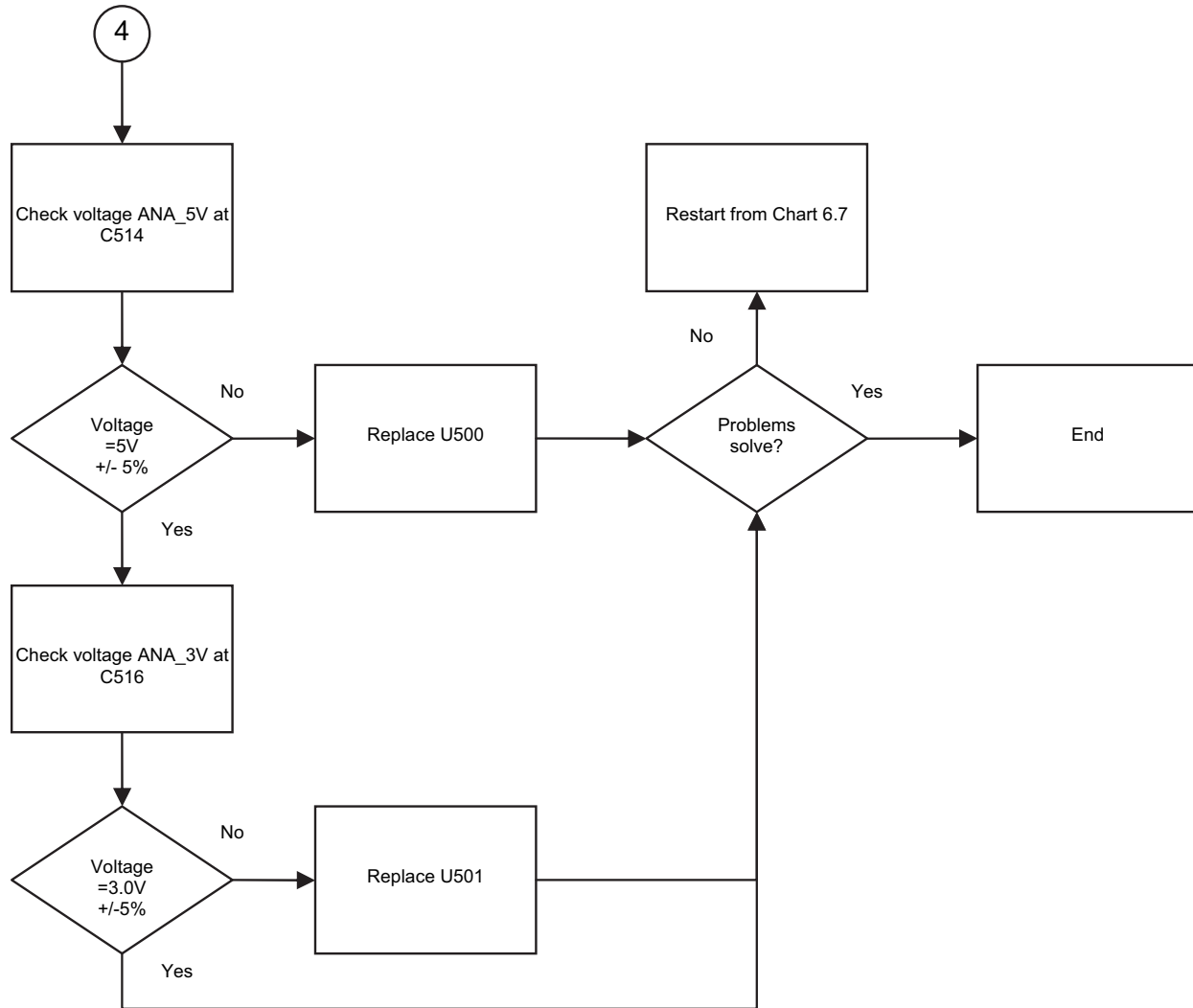

6.3.10 Button Test Troubleshooting Chart

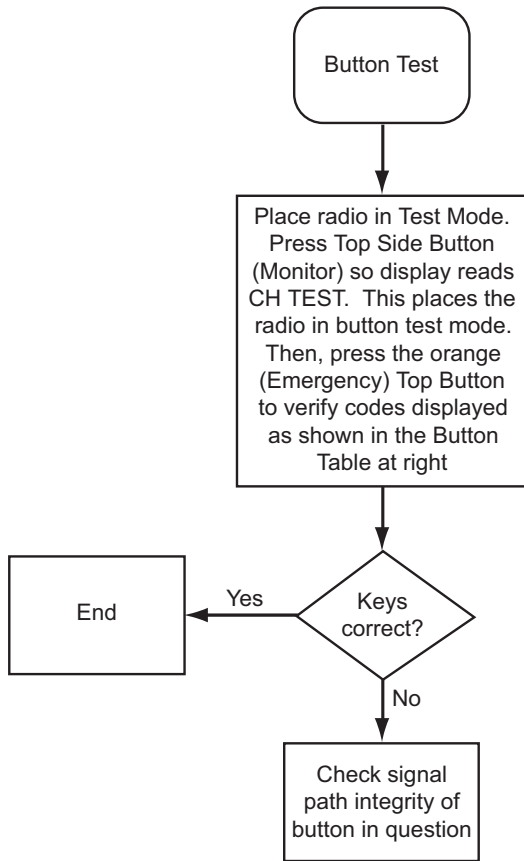

Synopsis

This chart relates to a failure in the button functions. Basic Failure modes are as follows:

- 1) Failure in keypad flex assembly.
- 2) Bad Connection
- 3) Defective Switches or pads
- 4) Defective MAKO IC (U701)

Button Table

Button	Code	Chart
PTT	1/ 0-1	
Top Button (Emergency)	3/ 0-1	C.6
Side Button 1 (Monitor)	96/ 0-1	C.6
Side Button 2	97/ 0-1	C.6
Side Button 3	98/ 0-1	C.6
Channel Select (Frequency)	4/ 0-15	C.8
Volume Control Knob	0/ 0-220	C.7
Zone Select	65/ 0-2	C.8

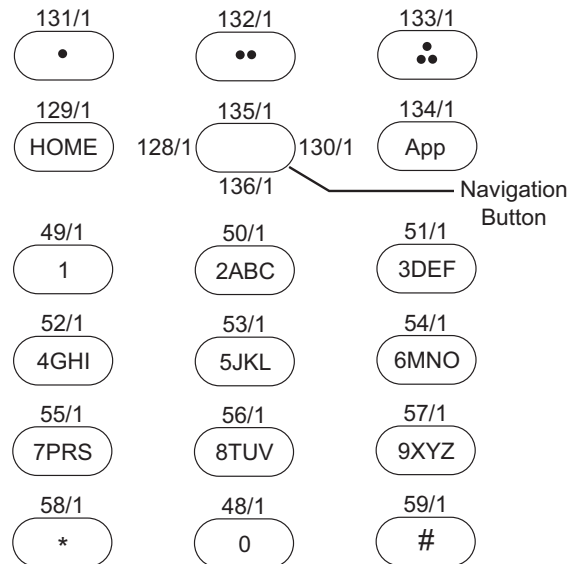

MAEPF-27335-O

6.3.11 Volume Set Error Troubleshooting Chart

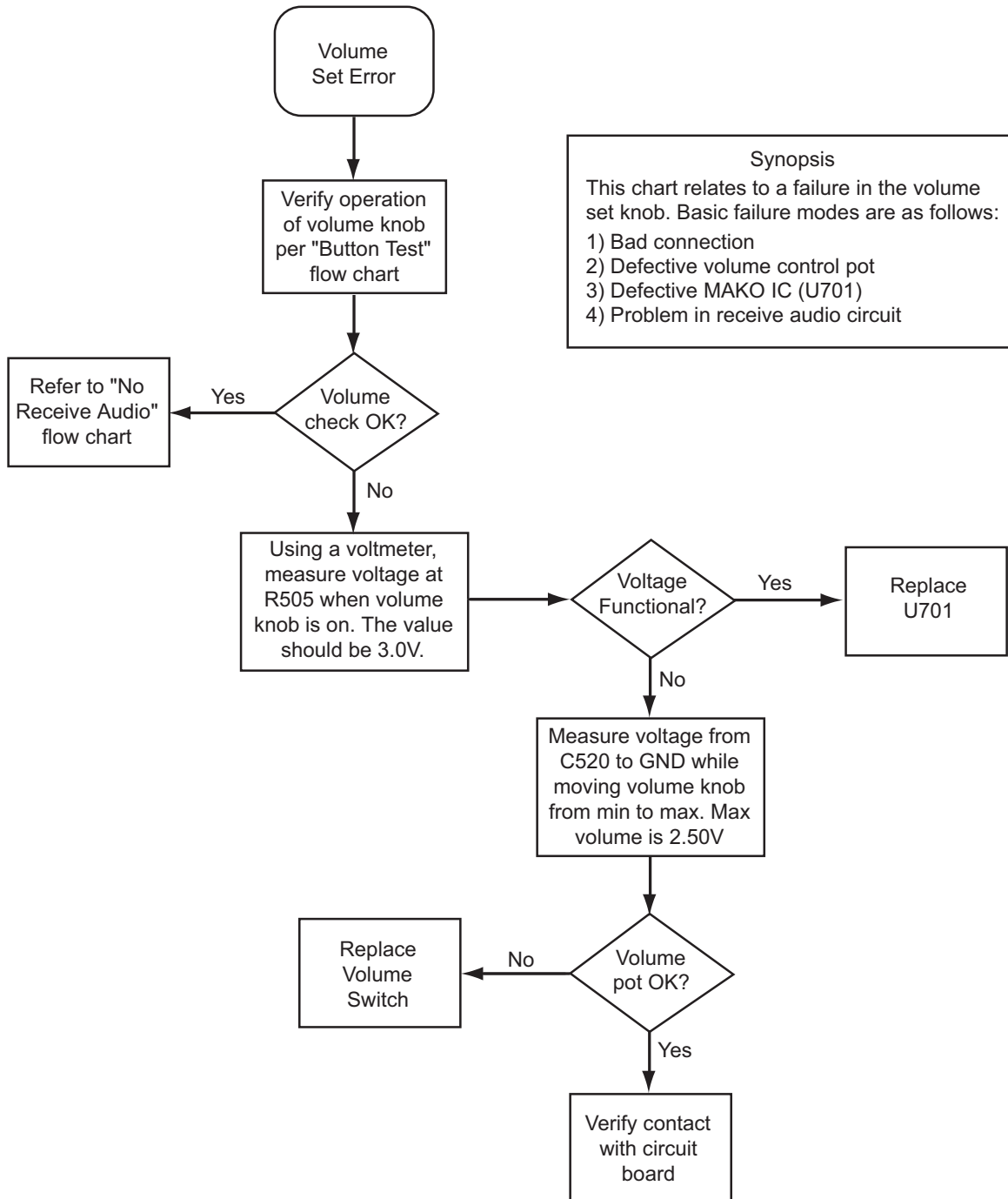

Synopsis
 This chart relates to a failure in the volume set knob. Basic failure modes are as follows:
 1) Bad connection
 2) Defective volume control pot
 3) Defective MAKO IC (U701)
 4) Problem in receive audio circuit

MAEPF-27336-O

6.3.12 Zone/Channel Select Error Troubleshooting Chart

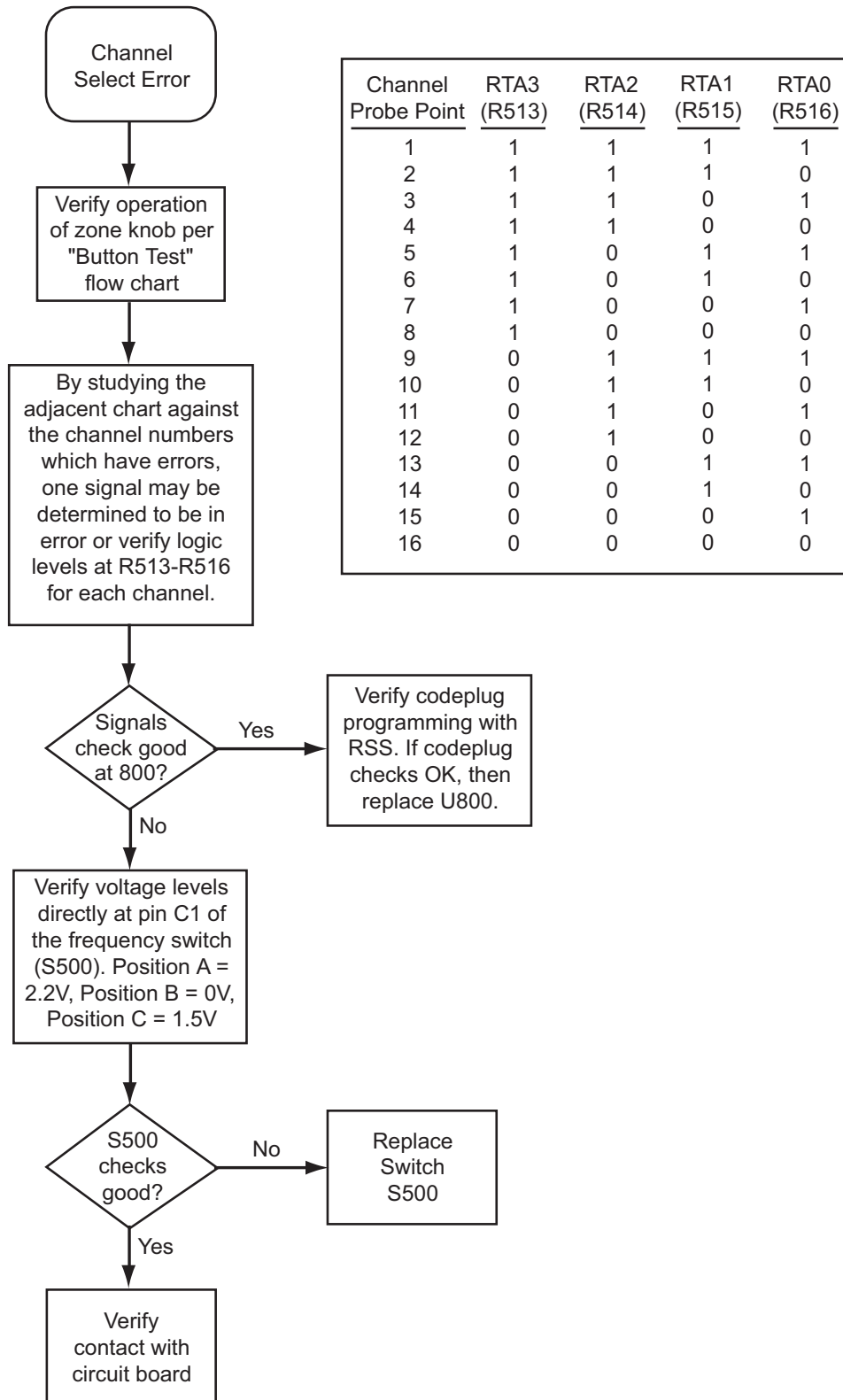

MAEPF-27337-O

6.3.13 Top/Side Button Error Troubleshooting Chart

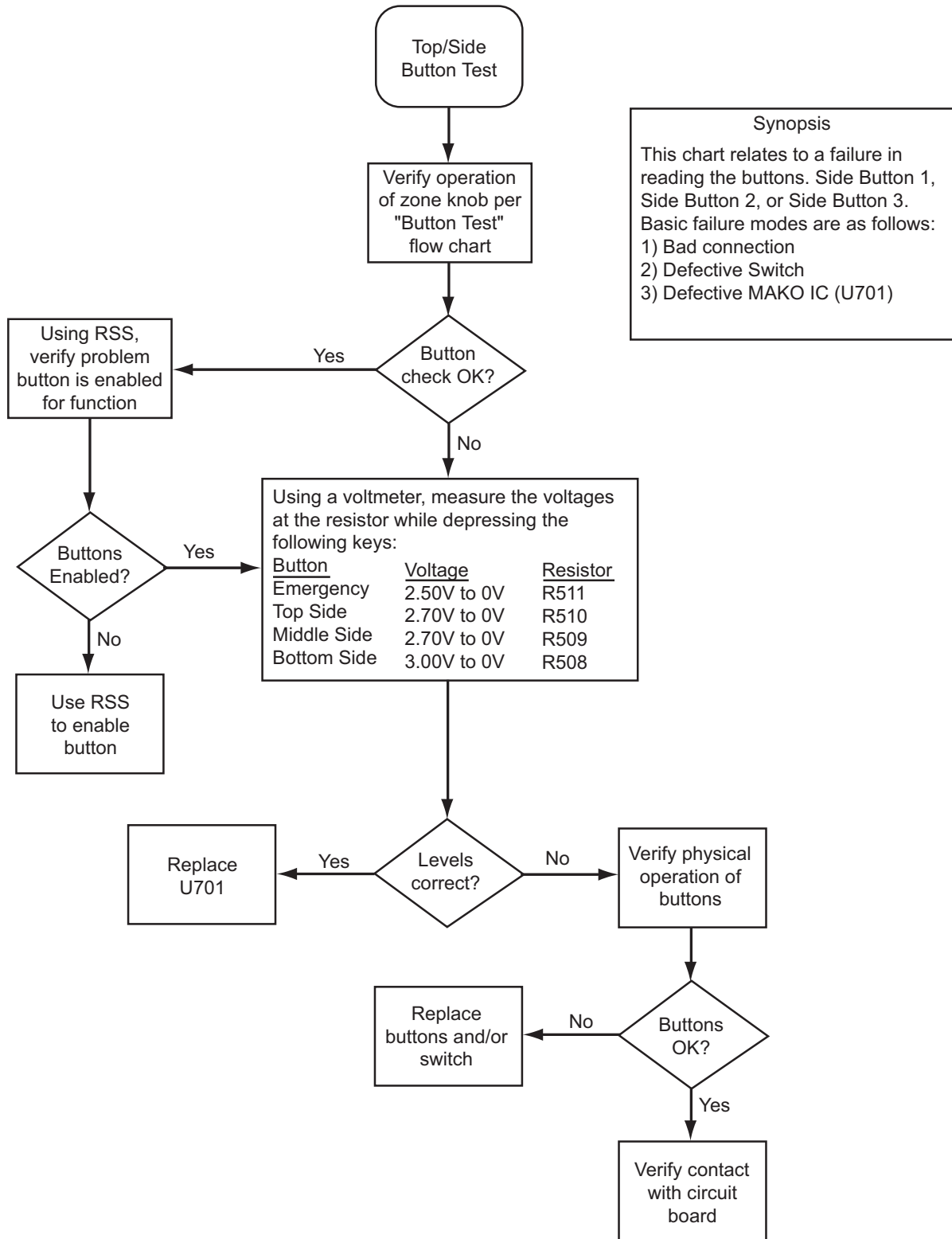

Synopsis

This chart relates to a failure in reading the buttons. Side Button 1, Side Button 2, or Side Button 3. Basic failure modes are as follows:

- 1) Bad connection
- 2) Defective Switch
- 3) Defective MAKO IC (U701)

MAEPF-27338-O

6.3.14 No Display Troubleshooting Chart (1 of 3)

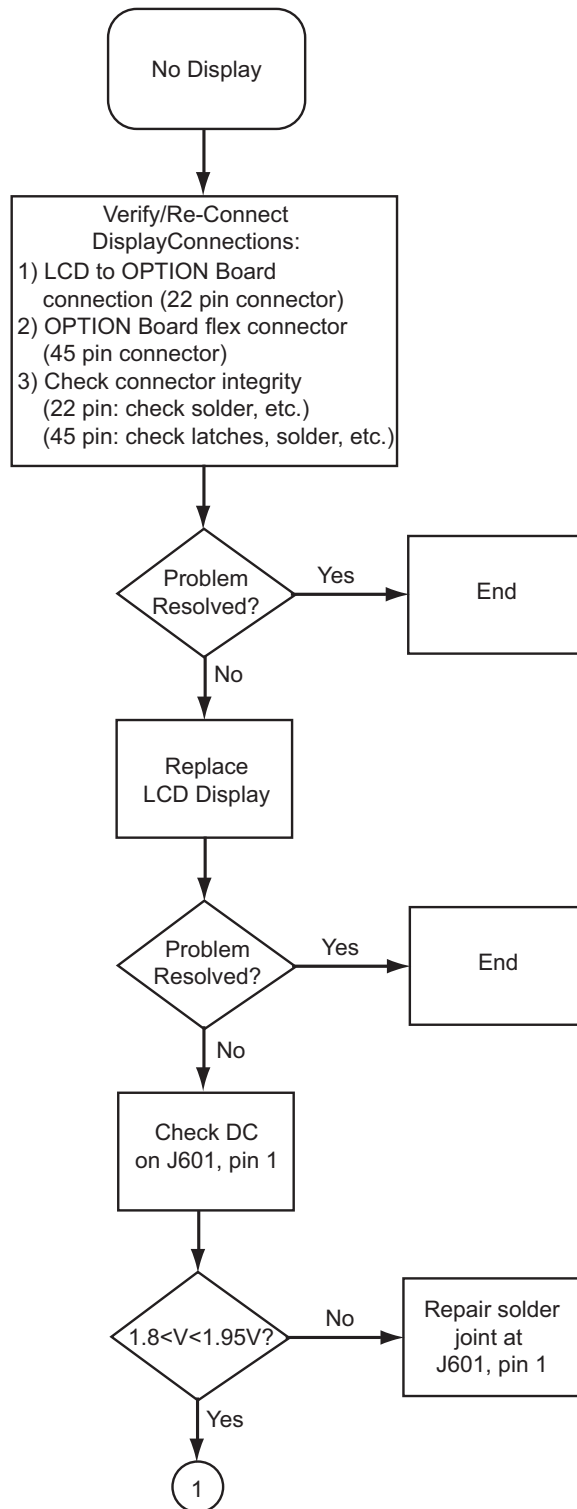

MAEPF-27339-O

6.3.15 No Display Troubleshooting Chart (2 of 3)

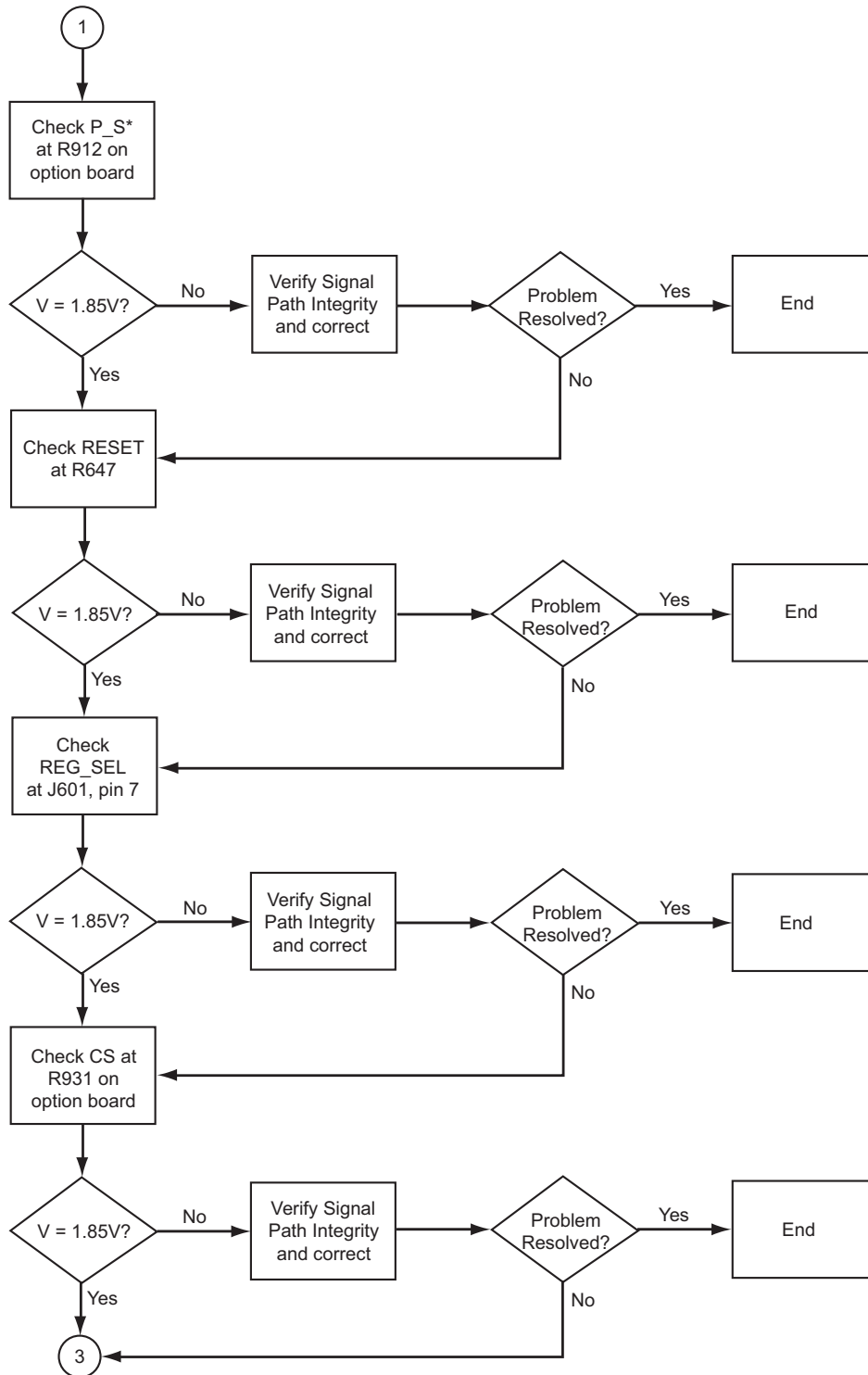

MAEPF-27340-O

6.3.16 No Display Troubleshooting Chart (3 of 3)

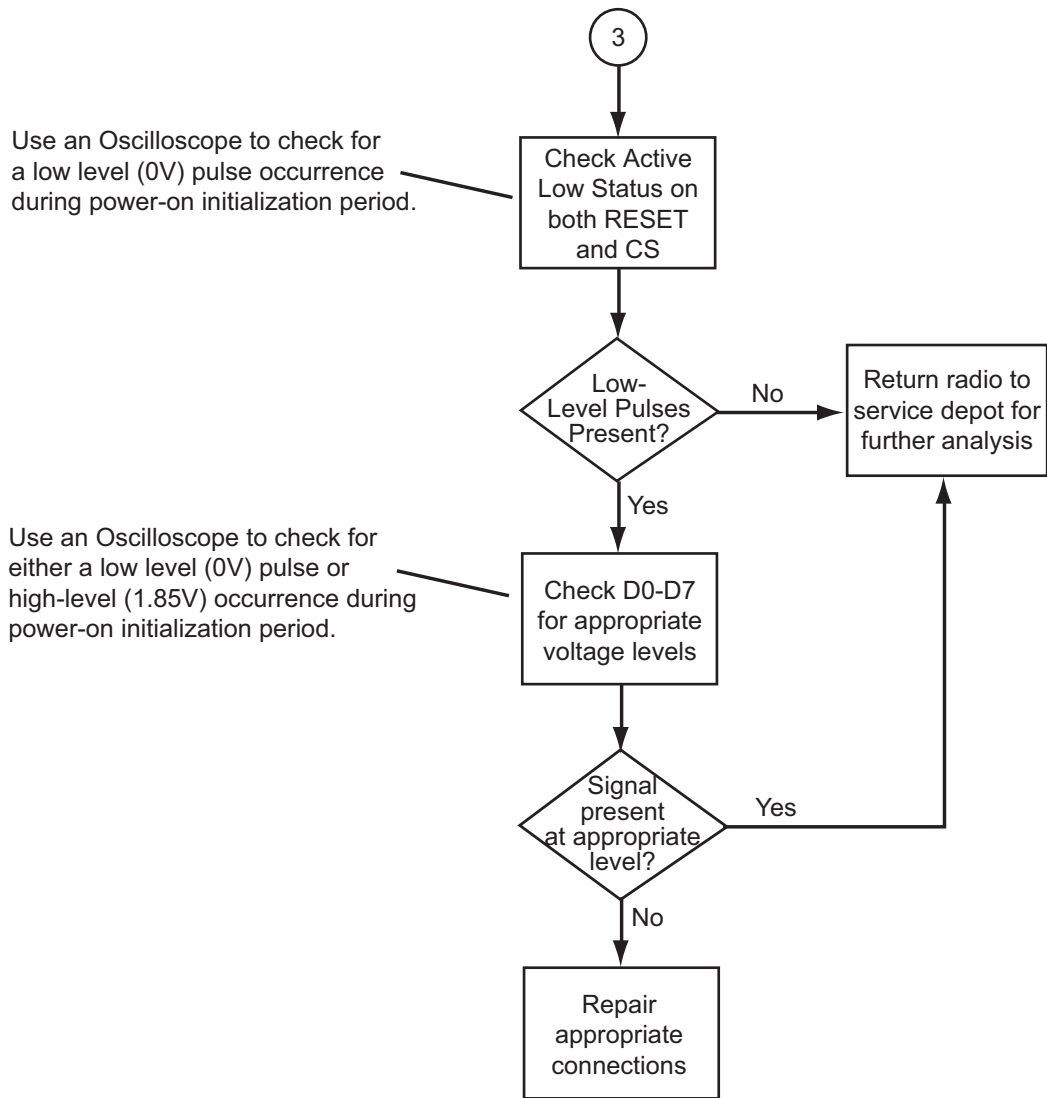

MAEPF-27341-O

6.3.17 UHF Range 2 Receive RF Troubleshooting Chart

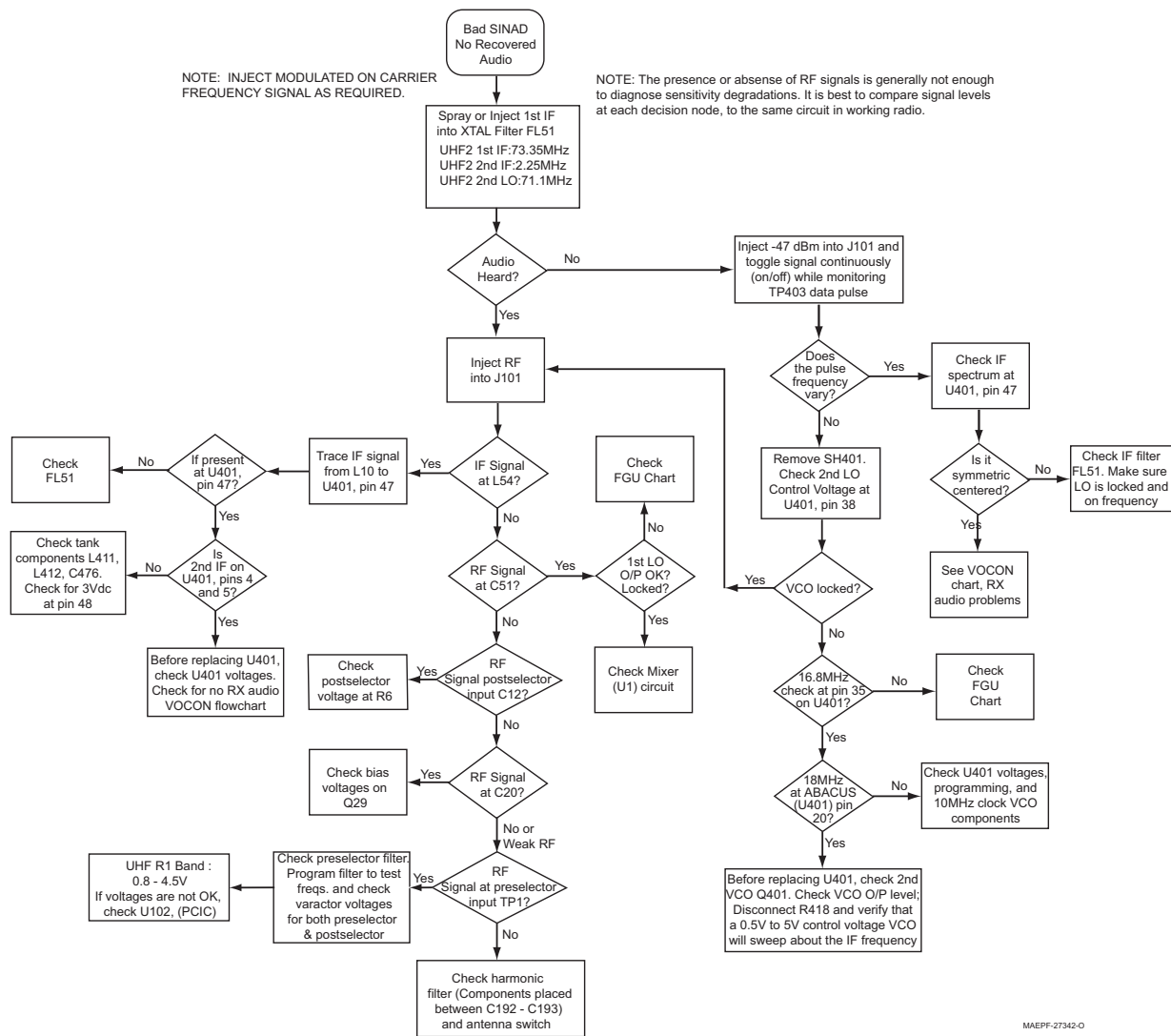

MAEPF-27342-0

6.3.18 VOCON Receive Audio Troubleshooting Chart

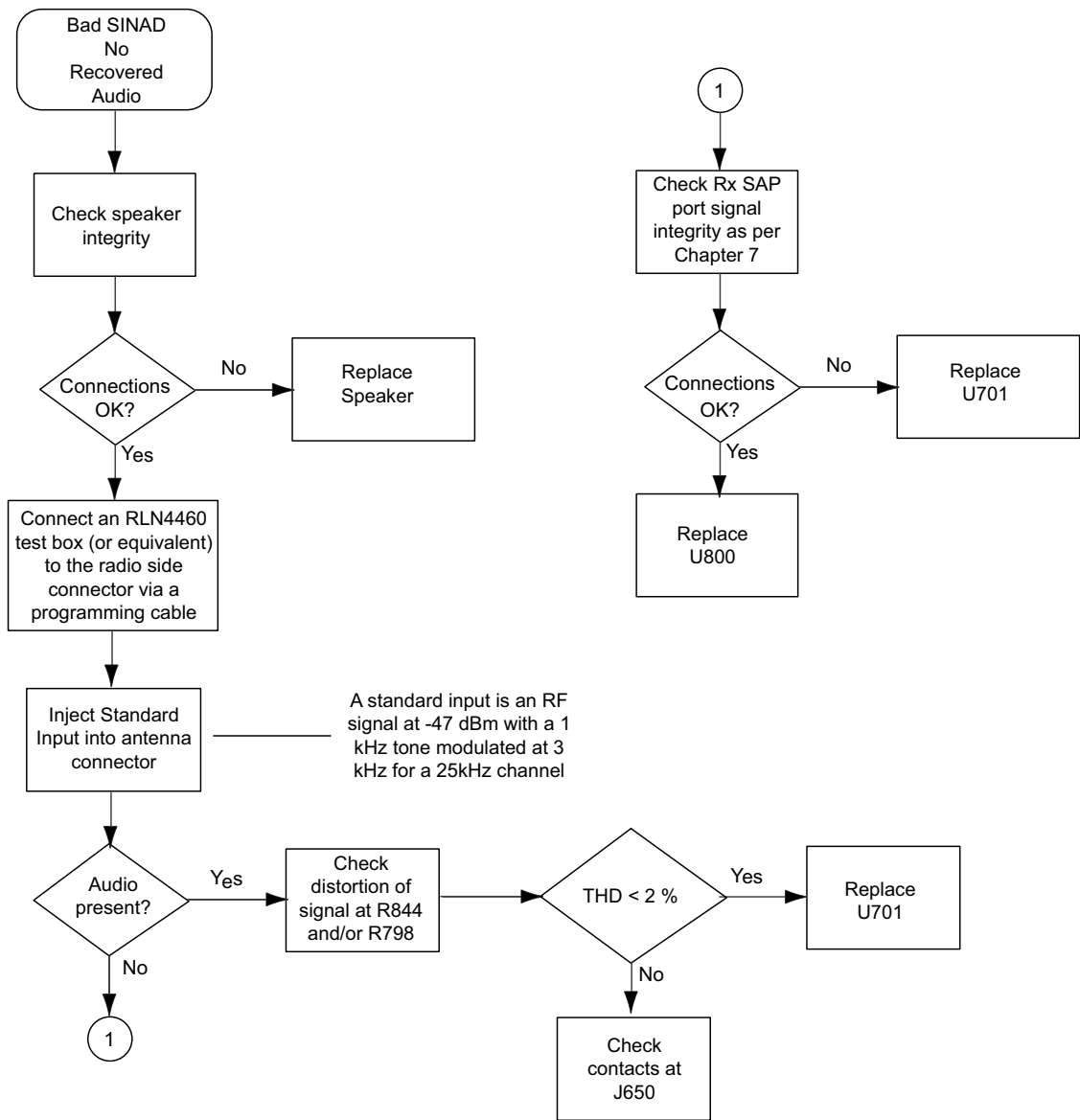

MAEPF-27347-O

6.3.19 UHF Range 2 Frequency Generation Unit Troubleshooting Chart

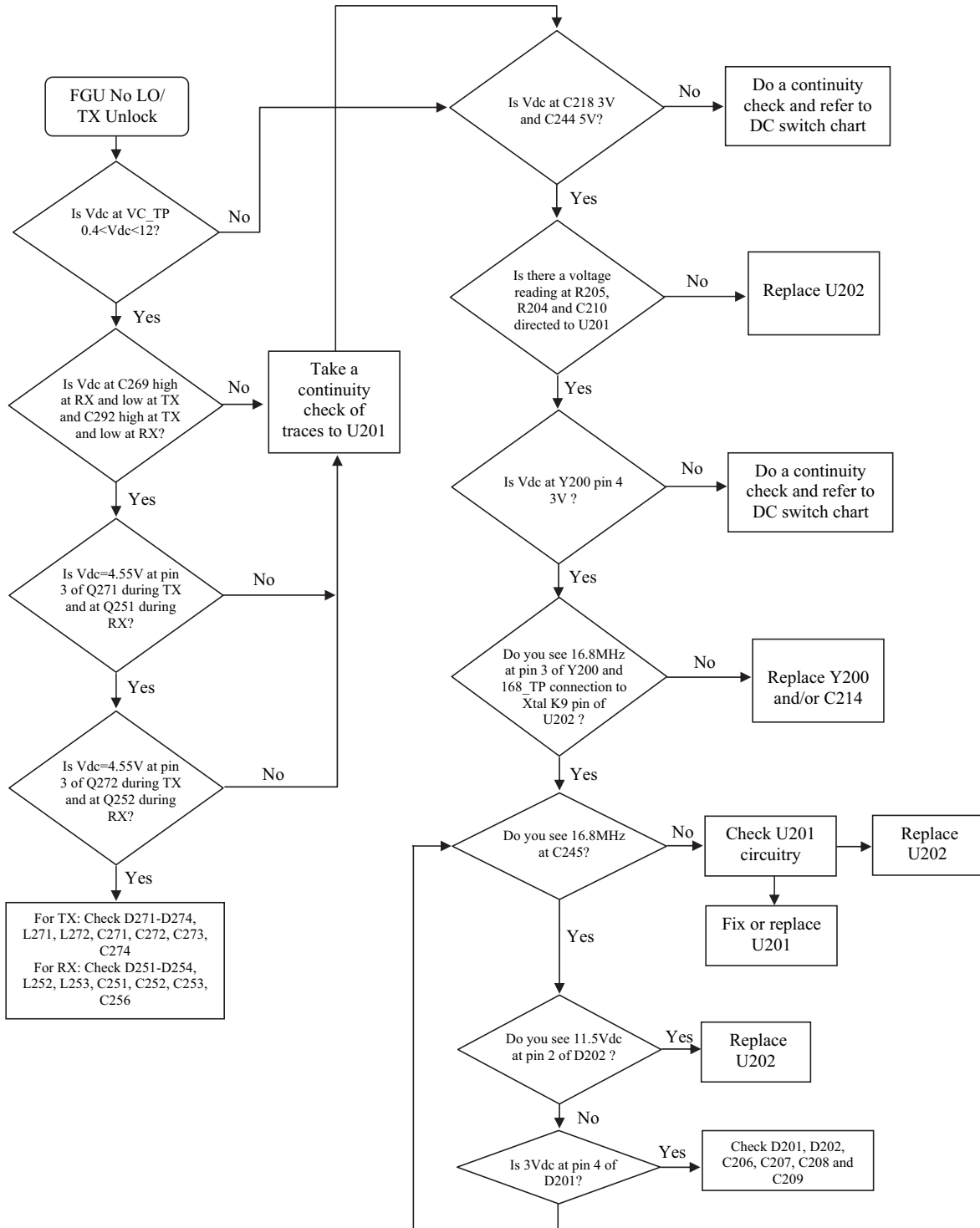

6.3.20 VOCON Transmit Audio Troubleshooting Chart (1 of 2)

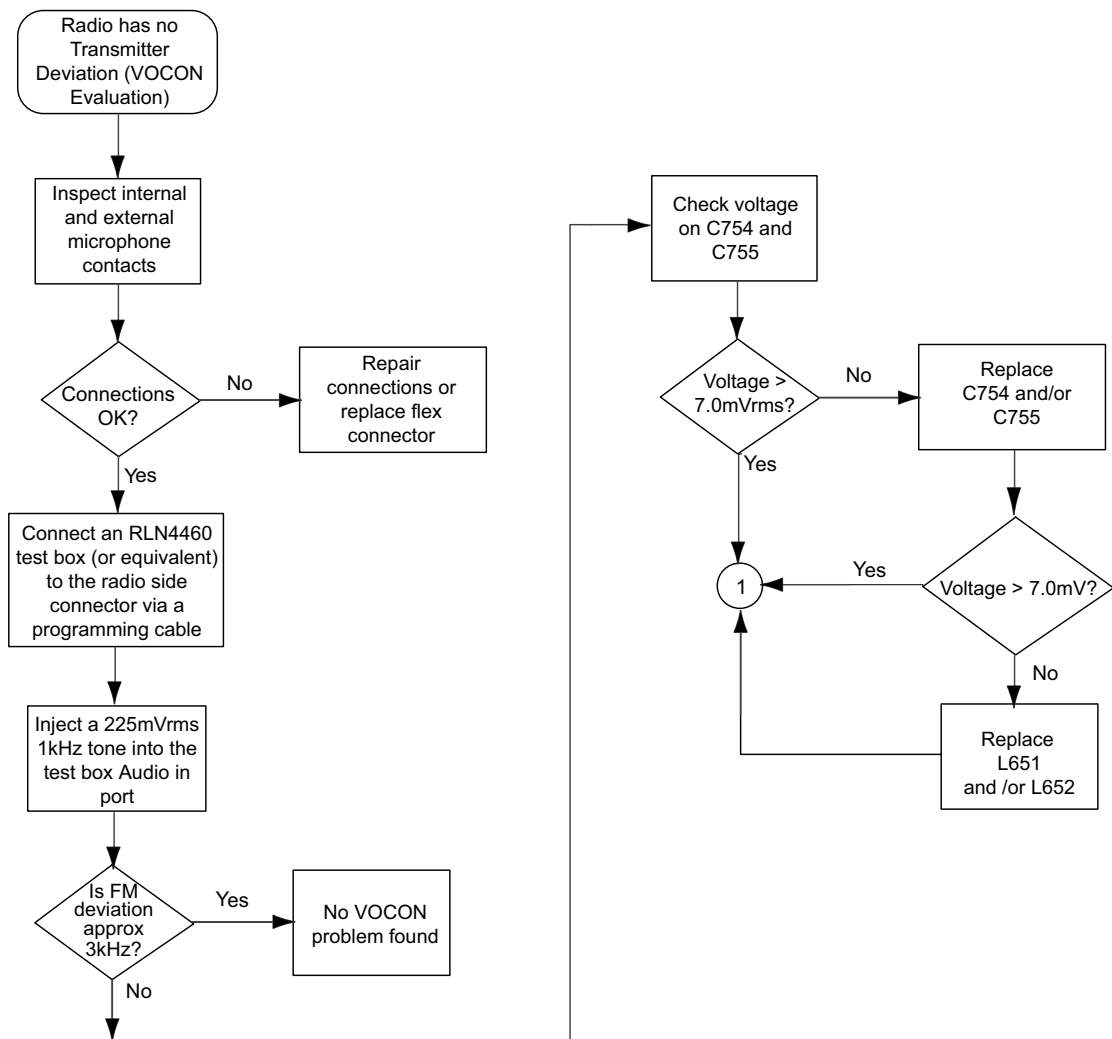

MAEPF-27347-O

6.3.21 VOCON Transmit Audio Troubleshooting Chart (2 of 2)

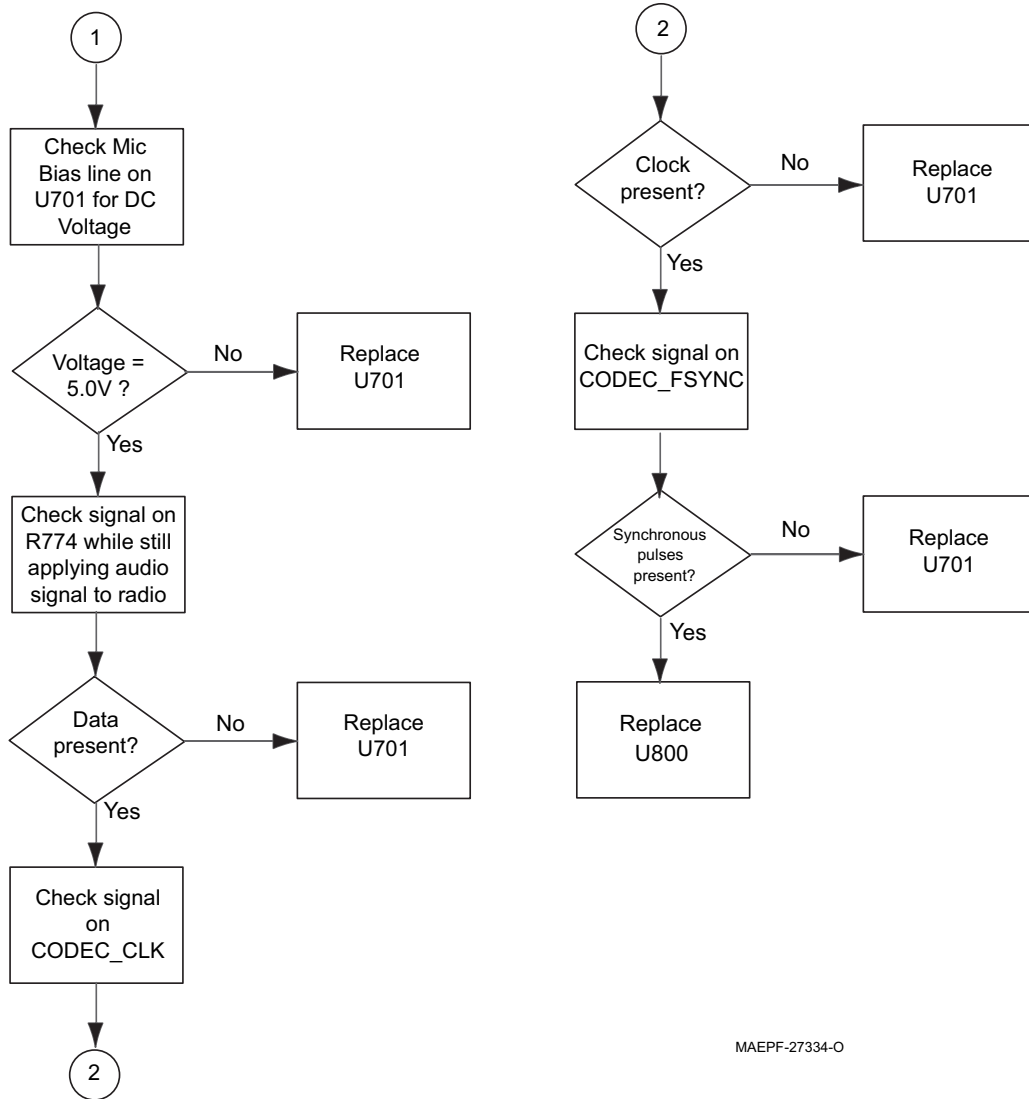

MAEPF-27334-O

6.3.22 No Transmit Deviation Troubleshooting Chart

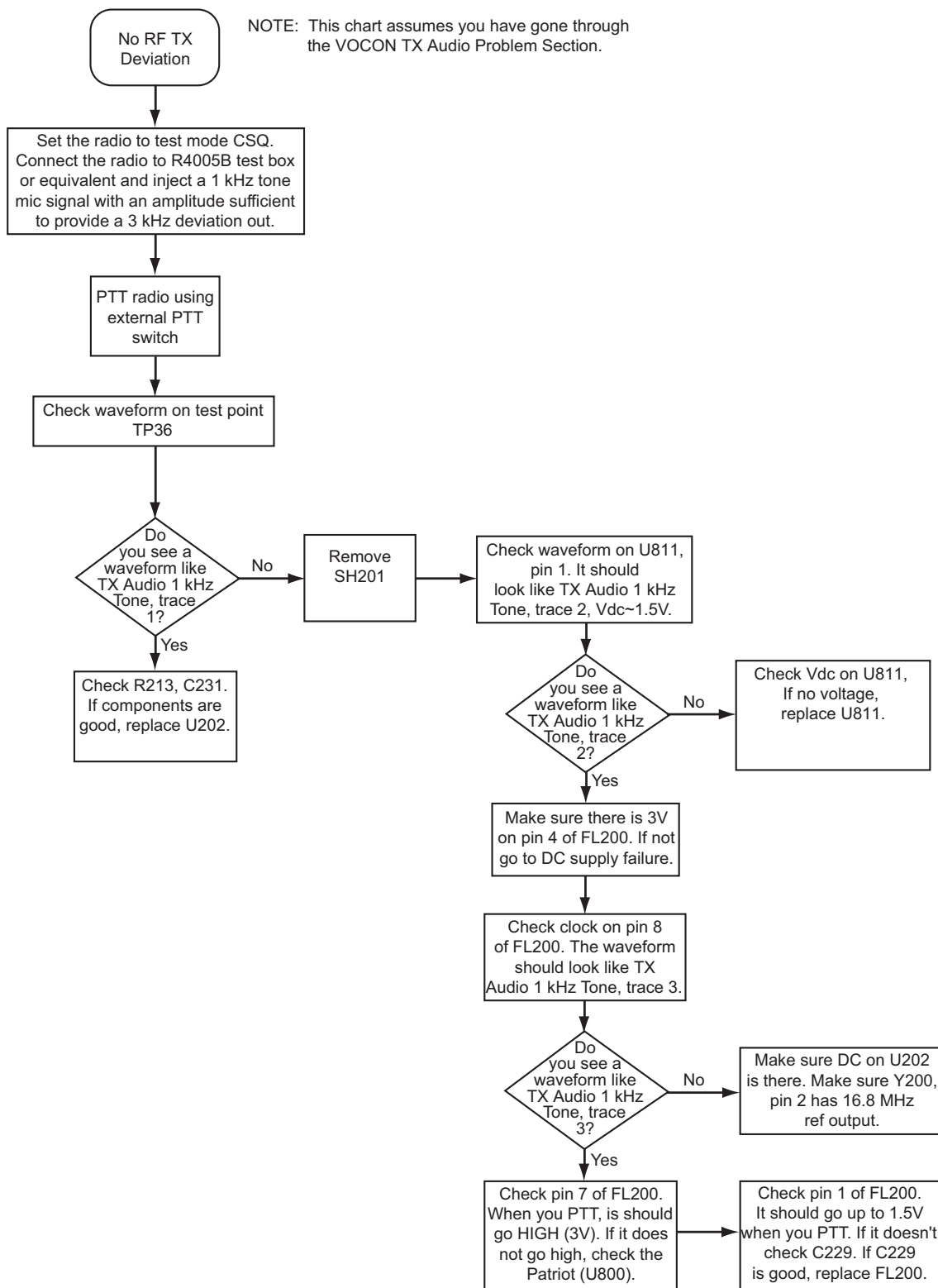

MAEPF-27343-O

6.3.23 UHF Range 2 Transmitter RF Troubleshooting Chart

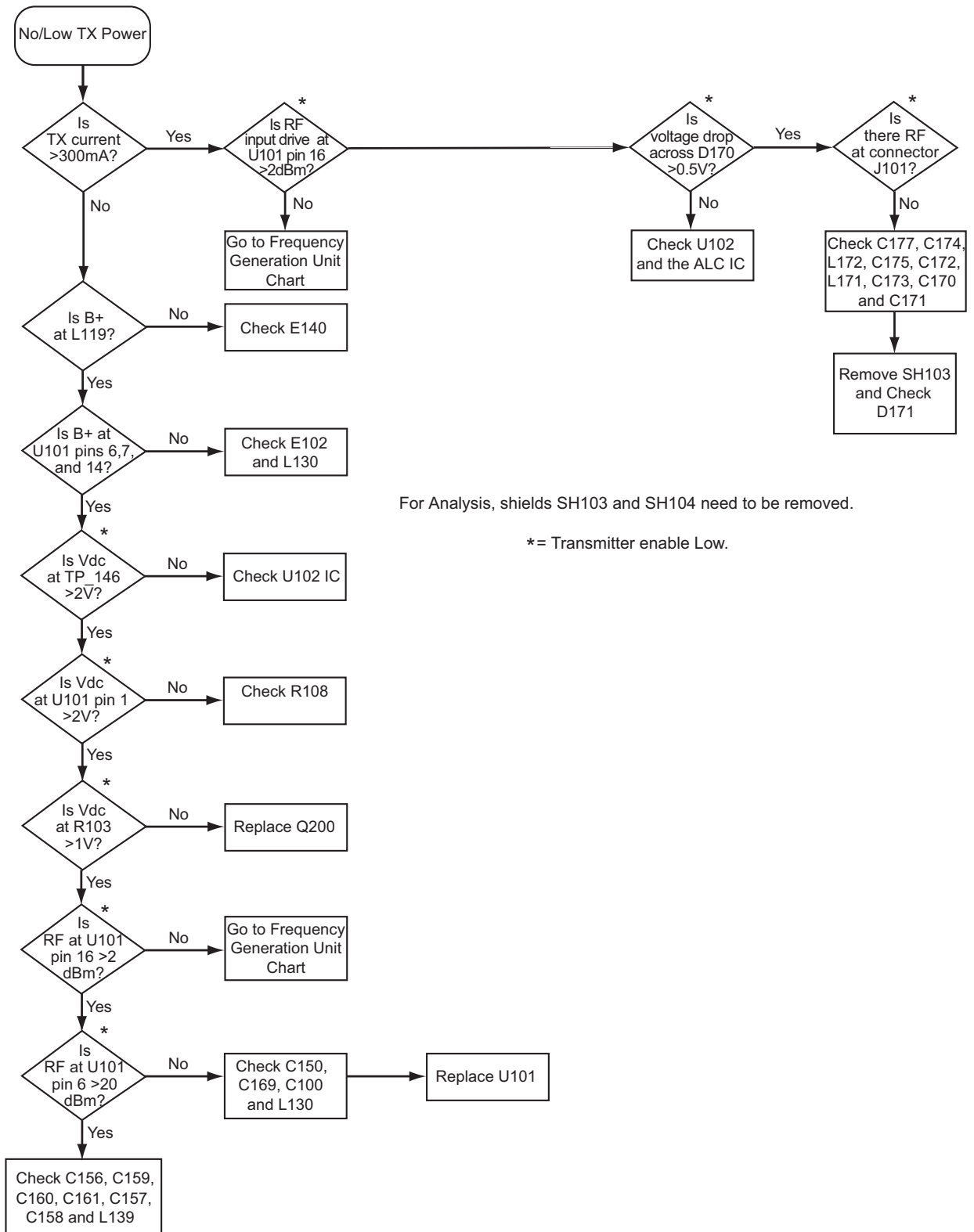

For Analysis, shields SH103 and SH104 need to be removed.

*= Transmitter enable Low.

6.3.24 Secure Hardware Failure

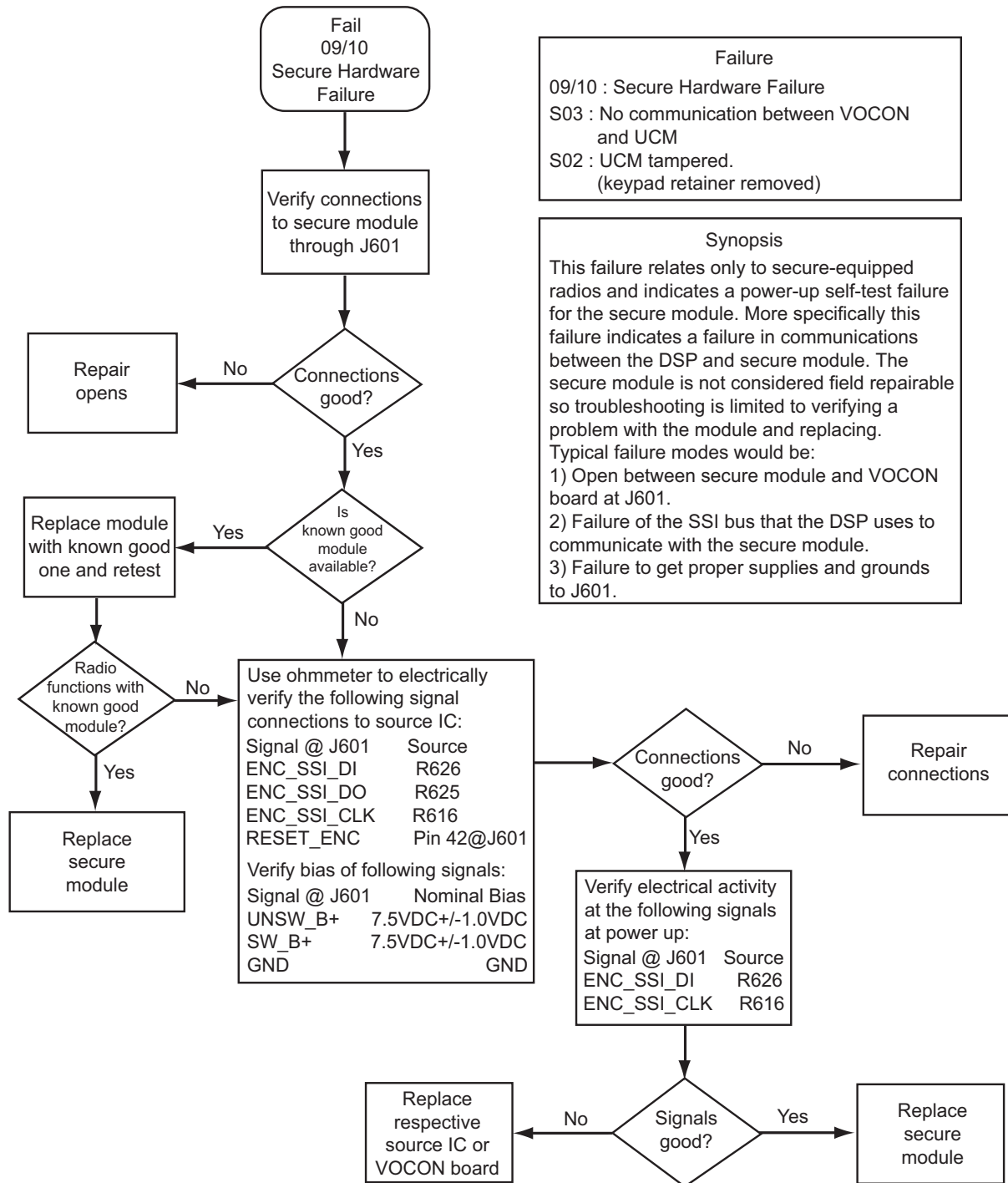

MAEPF-27387-O

Notes

Chapter 6.4 700/800 MHz Troubleshooting Charts

6.4.1 Introduction

This chapter contains detailed troubleshooting flowcharts. These flowcharts are for use as a guide in determining the problem areas. They are not a substitute for the knowledge of circuit operation and astute troubleshooting techniques. It is advisable to refer to the related detailed circuit descriptions in the theory sections prior to troubleshooting a radio.

This manual is to be used in conjunction with the ASTRO XTS 2500/XTS 2500I Digital Portable Radios Basic Service Manual (Motorola part number 6816984H01), which uses the pass/fail service approach to radio problems.

6.4.2 List of Troubleshooting Flowcharts

Most troubleshooting flowcharts end up by pointing to an IC to replace. **It is not always noted, but it is good practice to verify supplies and grounds to the affected IC and to trace continuity to the malfunctioning signal and related circuitry before replacing any IC.** For instance, if a clock signal is not available at a destination IC, continuity from the source IC should be checked before replacing the source IC.

Table 6.4-1. List of Troubleshooting Flowcharts

Chart Name	Page No.
700/800 MHz Radio Main Troubleshooting Chart	6.4-2
Radio Power-Up Fail Troubleshooting Chart	6.4-3
DC Supply Fail Troubleshooting Chart	6.4-6
Button Test Troubleshooting Chart	6.4-9
Volume Set Error Troubleshooting Chart	6.4-10
Zone/Channel Select Error Troubleshooting Chart	6.4-11
Top/Side Button Error Troubleshooting Chart	6.4-12
No Display Troubleshooting Chart	6.4-15
700/800 MHz Receive RF Troubleshooting Chart	6.4-16
VOCON Receive Audio Troubleshooting Chart	6.4-17
700/800 MHz Frequency Generation Unit Troubleshooting Chart	6.4-18
VOCON Transmit Audio Troubleshooting Chart	6.4-19
No Transmit Deviation Troubleshooting Chart	6.4-21
700/800 MHz Transmitter RF Troubleshooting Chart	6.4-22
Secure Hardware Failure	6.4-23

NOTE: μC is used in several of the following troubleshooting charts.
 μC = microcontroller unit (MCU).

6.4.3 700/800 MHz Radio Main Troubleshooting Chart

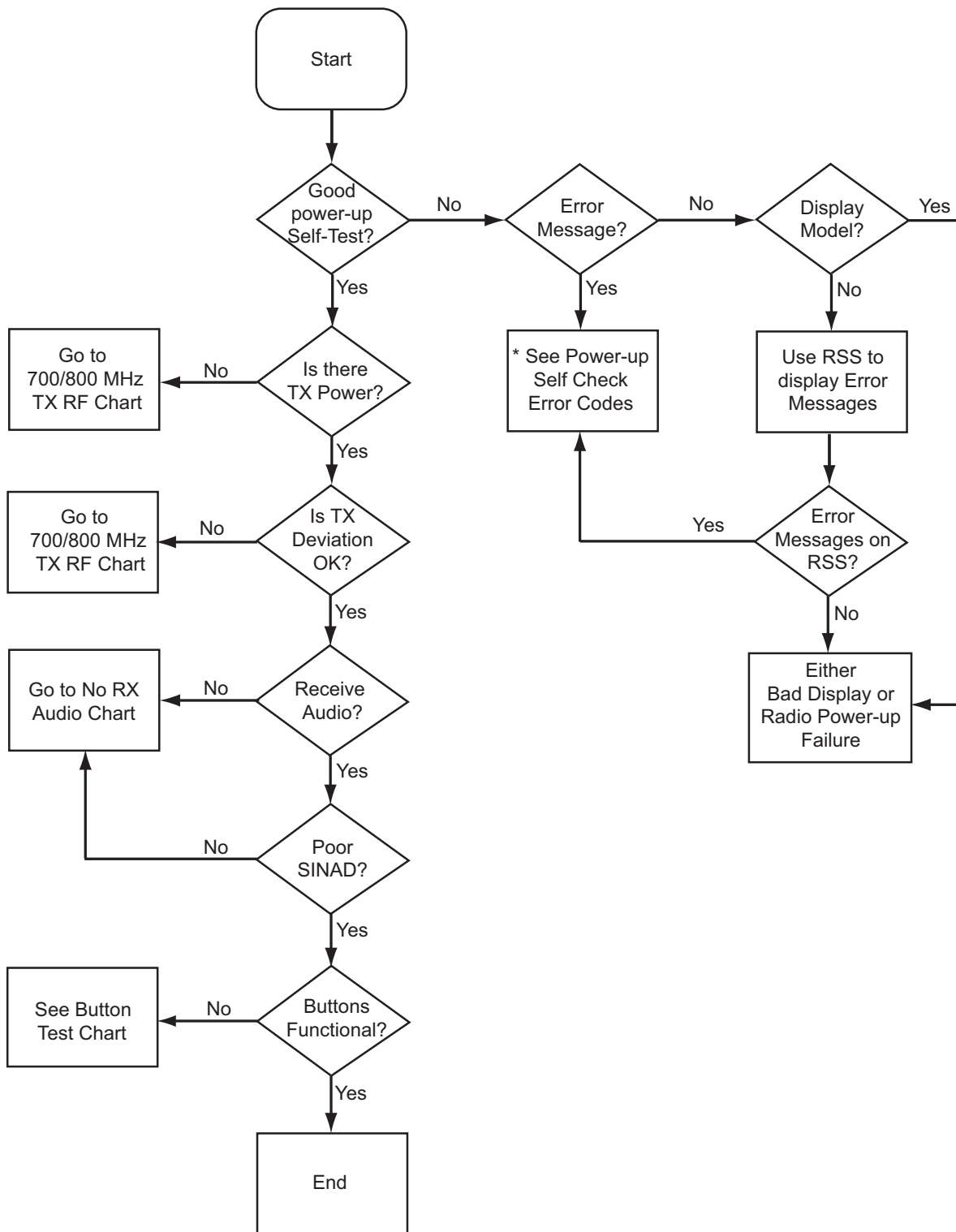

*Please see Table 5-2 on page 5-3.

6.4.4 Radio Power-Up Fail Troubleshooting Chart (1 of 3)

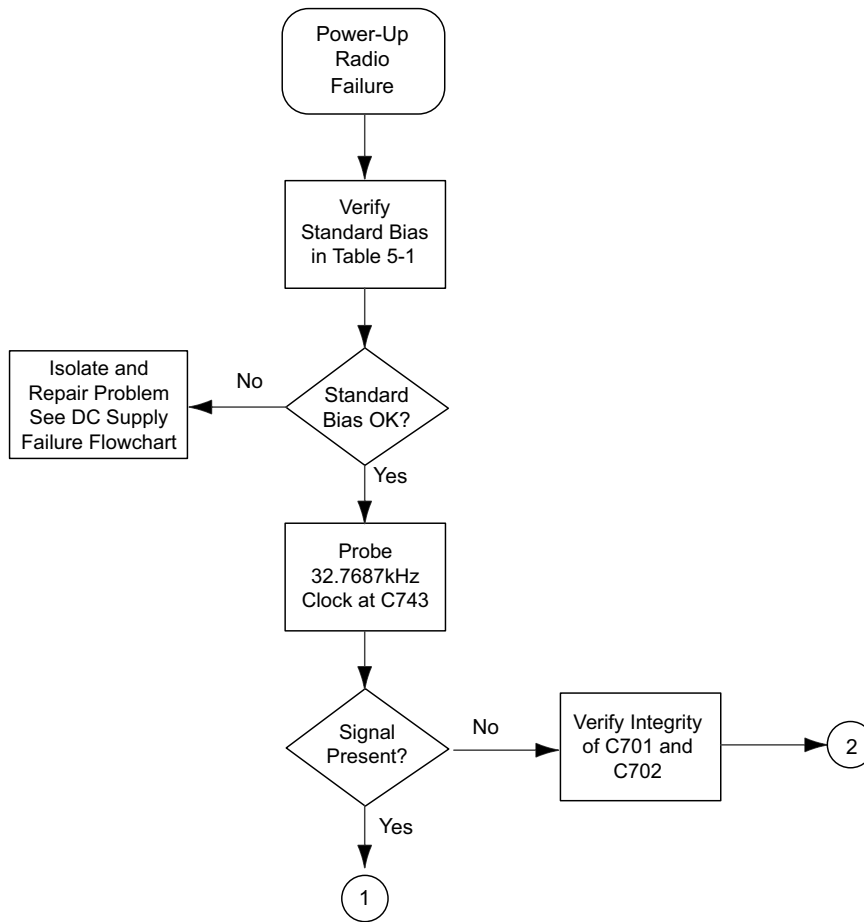

6.4.5 Radio Power-Up Fail Troubleshooting Chart (2 of 3)

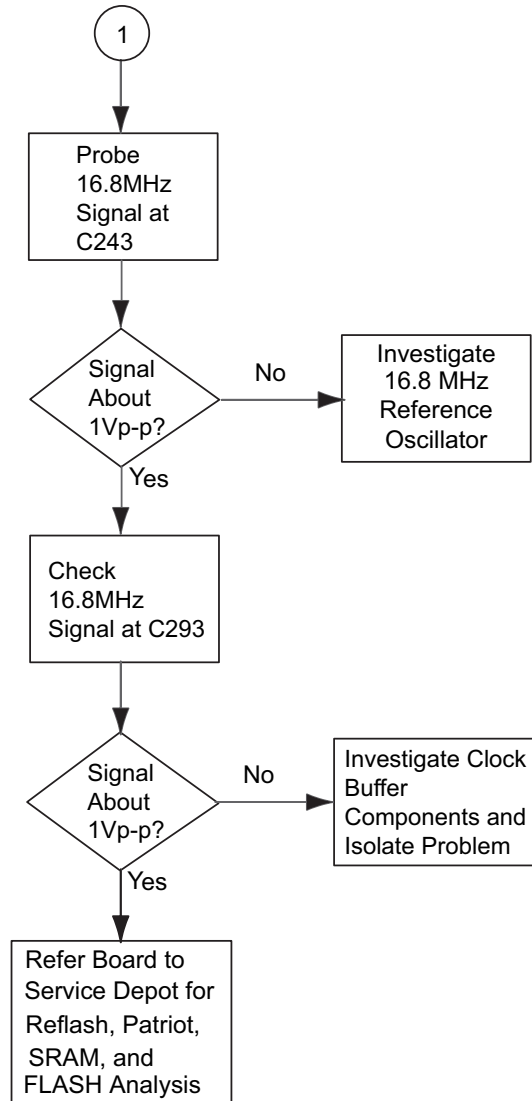

6.4.6 Radio Power-Up Fail Troubleshooting Chart (3 of 3)

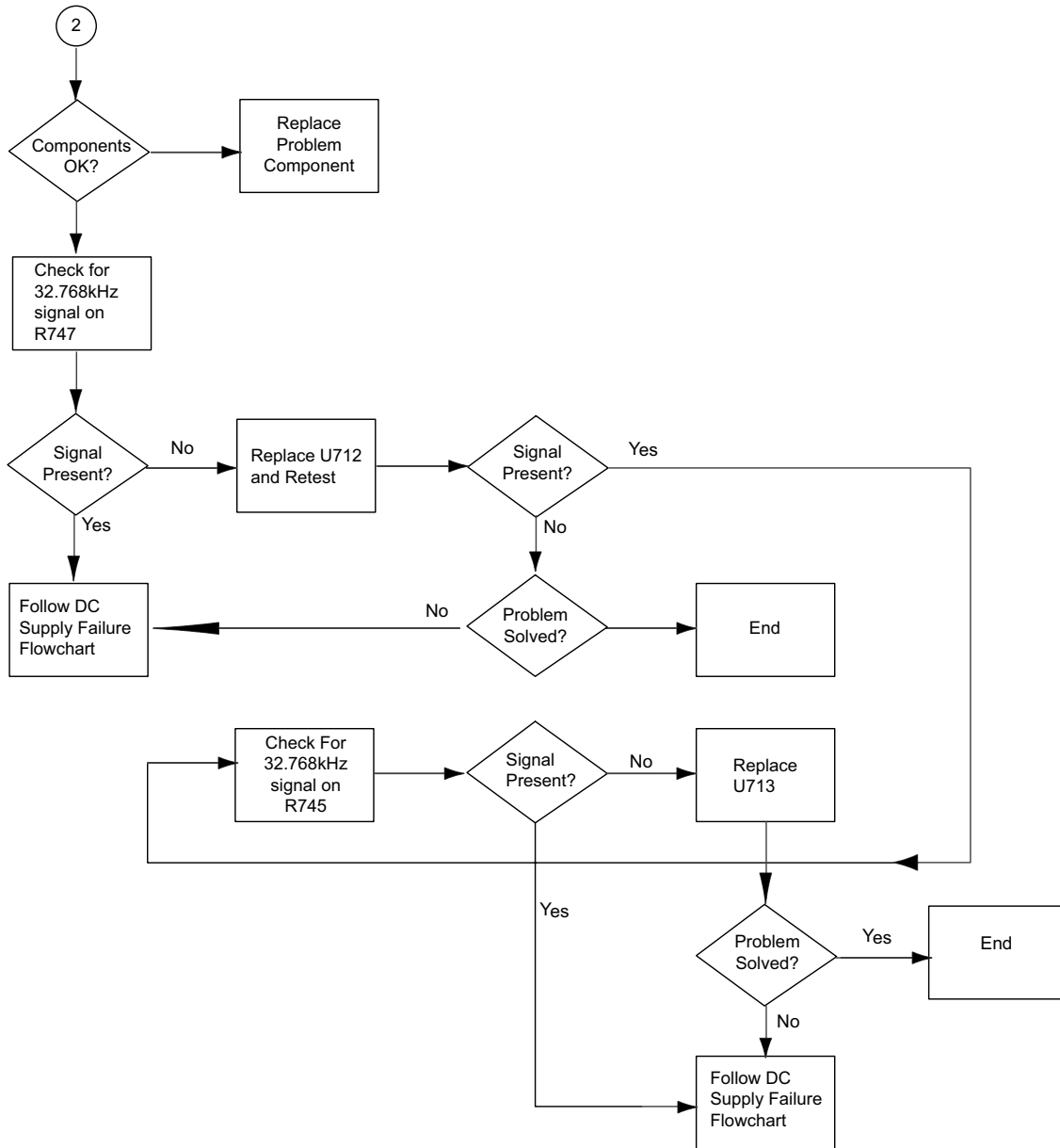

MAEPF-27333-O

6.4.7 DC Supply Fail Troubleshooting Chart (1 of 3)

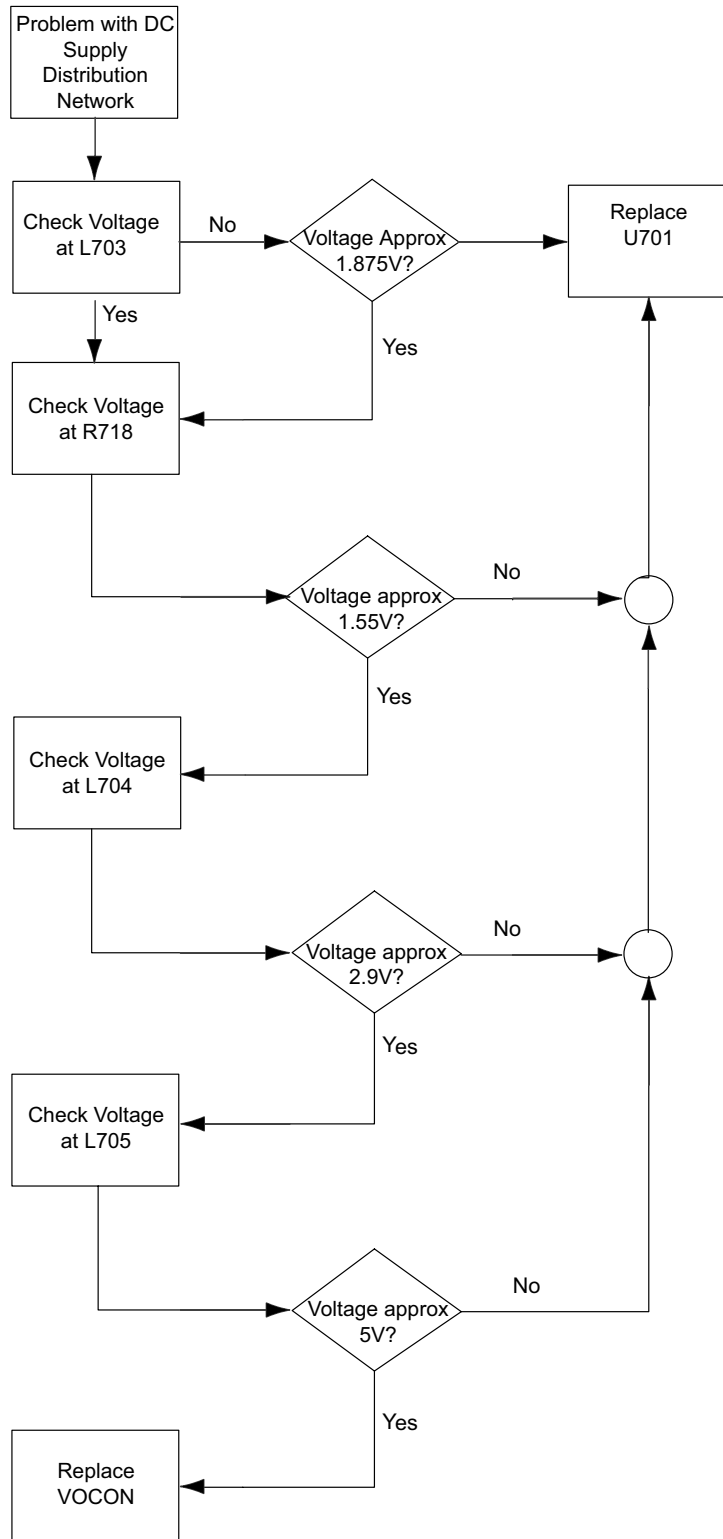

MAEPF-27334-O

6.4.8 DC Supply Fail Troubleshooting Chart (2 of 3)

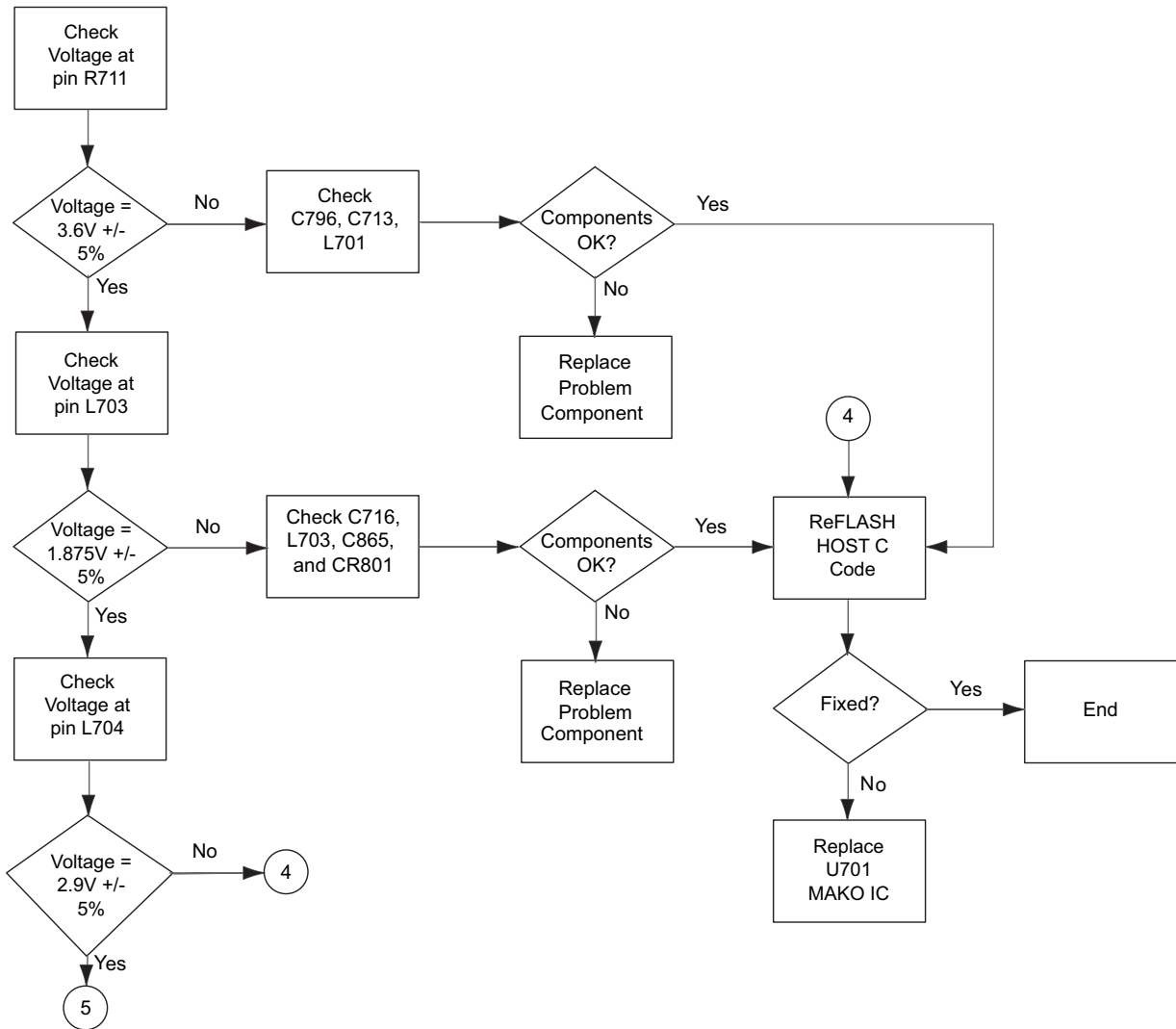

MAEPF-27333-O

6.4.9 DC Supply Fail Troubleshooting Chart (3 of 3)

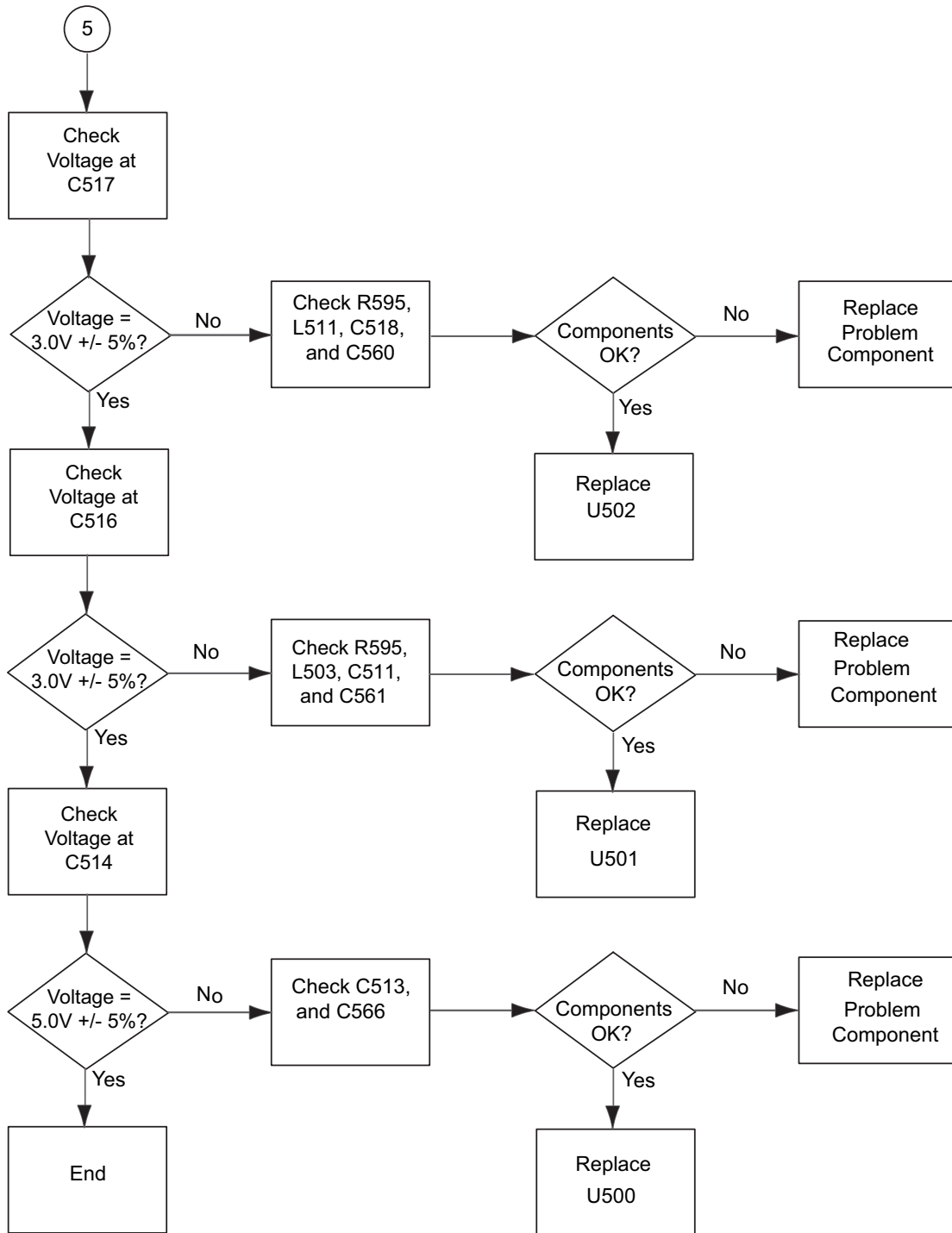

6.4.10 Button Test Troubleshooting Chart

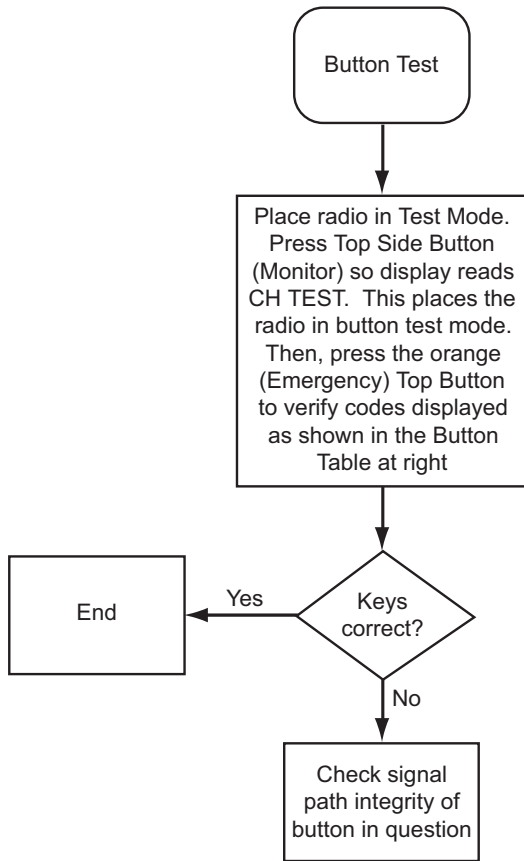

Synopsis

This chart relates to a failure in the button functions. Basic Failure modes are as follows:

- 1) Failure in keypad flex assembly.
- 2) Bad Connection
- 3) Defective Switches or pads
- 4) Defective MAKO IC (U701)

Button Table

Button	Code	Chart
PTT	1/ 0-1	
Top Button (Emergency)	3/ 0-1	C.6
Side Button 1 (Monitor)	96/ 0-1	C.6
Side Button 2	97/ 0-1	C.6
Side Button 3	98/ 0-1	C.6
Channel Select (Frequency)	4/ 0-15	C.8
Volume Control Knob	0/ 0-220	C.7
Zone Select	65/ 0-2	C.8

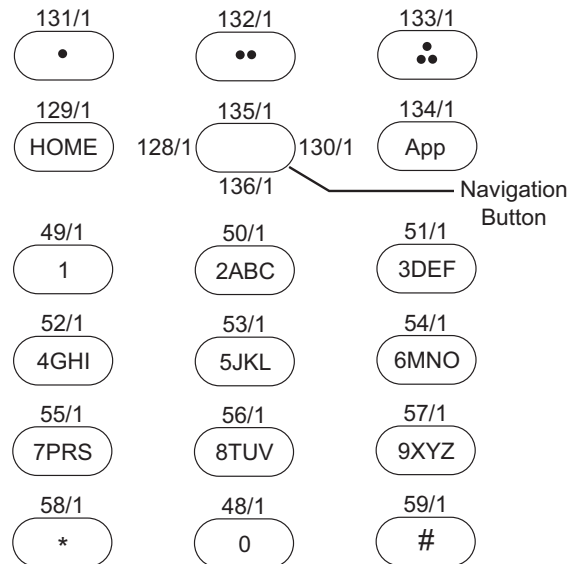

MAEPF-27335-O

6.4.11 Volume Set Error Troubleshooting Chart

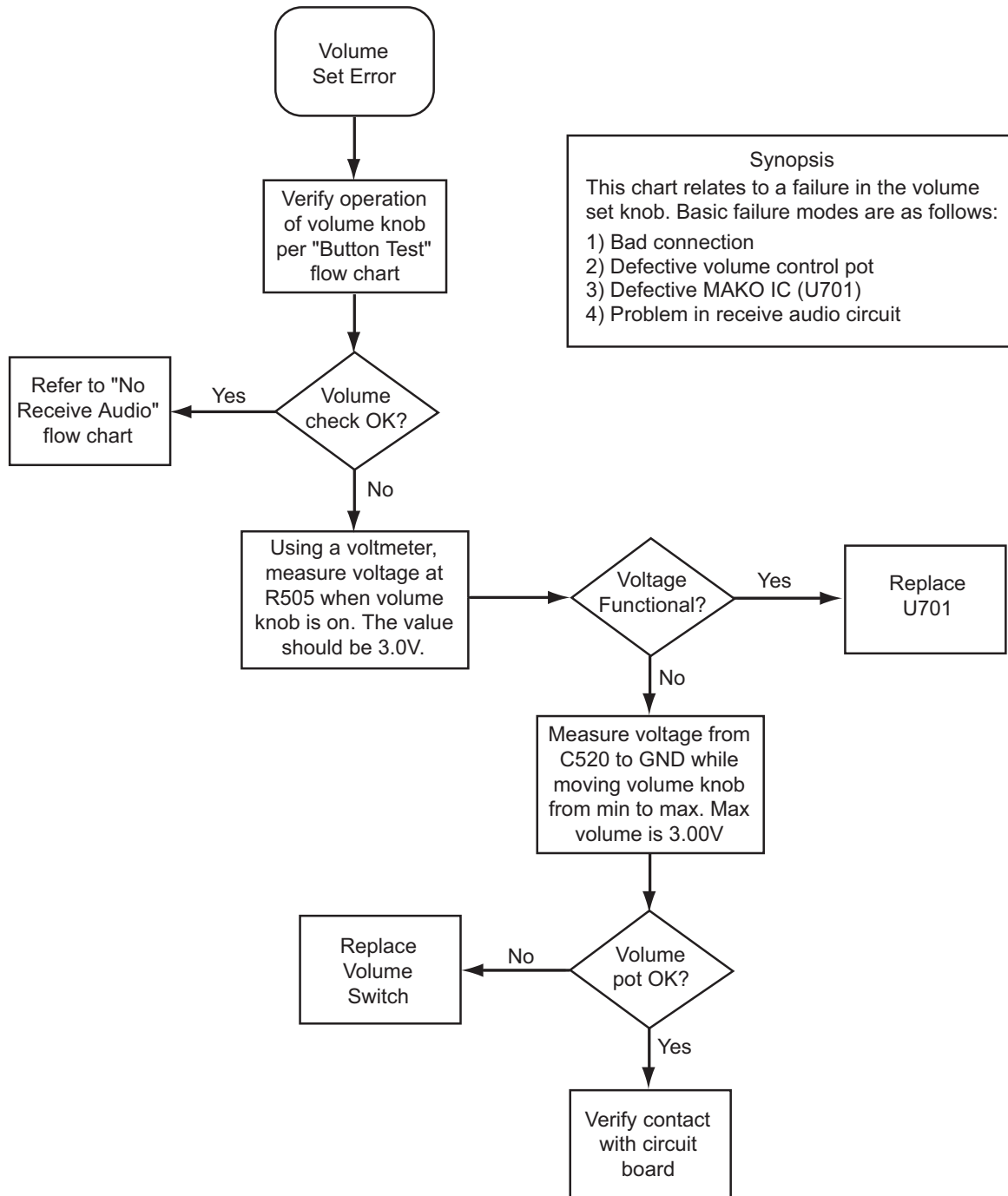

Synopsis

This chart relates to a failure in the volume set knob. Basic failure modes are as follows:

- 1) Bad connection
- 2) Defective volume control pot
- 3) Defective MAKO IC (U701)
- 4) Problem in receive audio circuit

MAEPF-27336-O

6.4.12 Zone/Channel Select Error Troubleshooting Chart

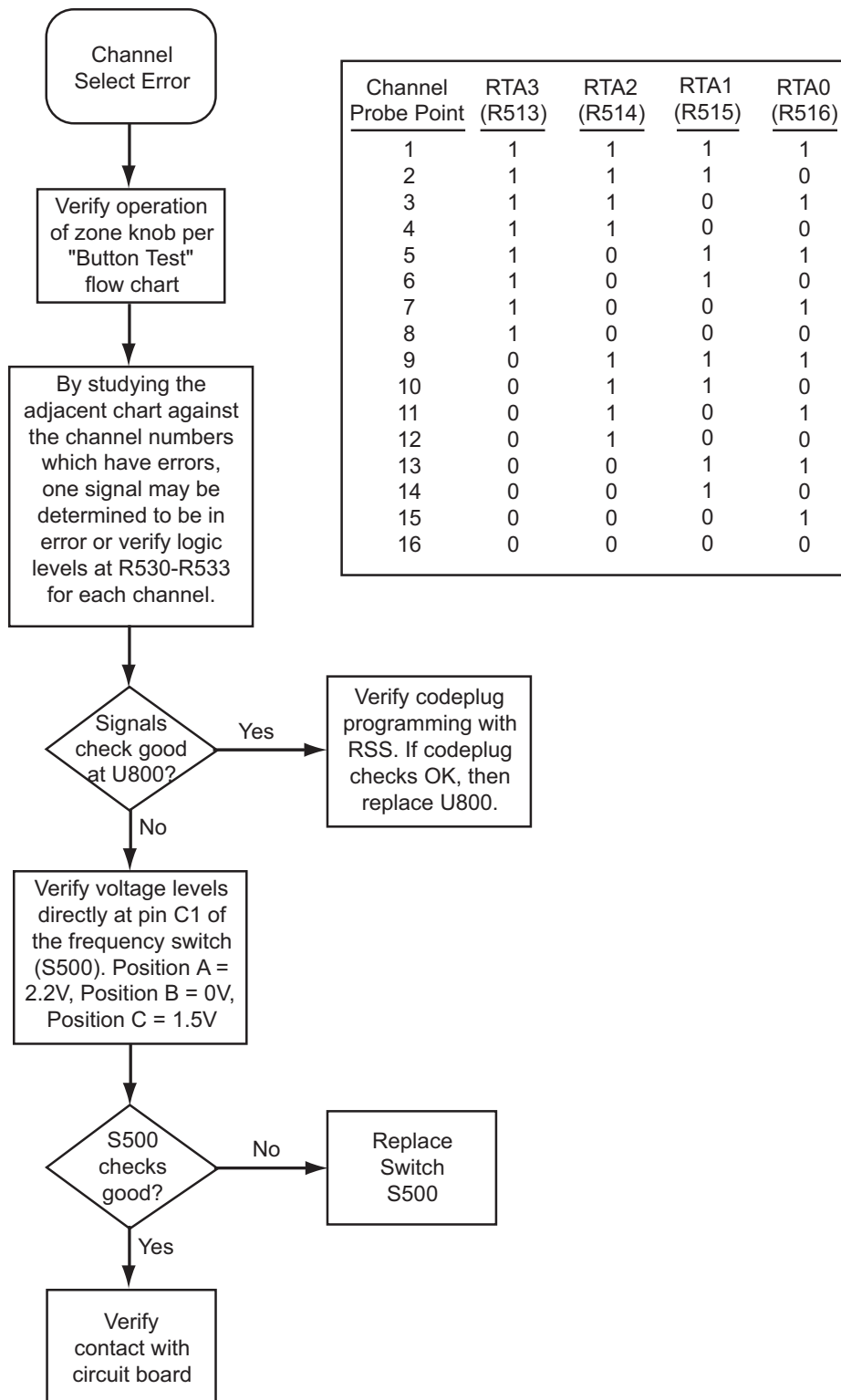

MAEPF-27337-O

6.4.13 Top/Side Button Error Troubleshooting Chart

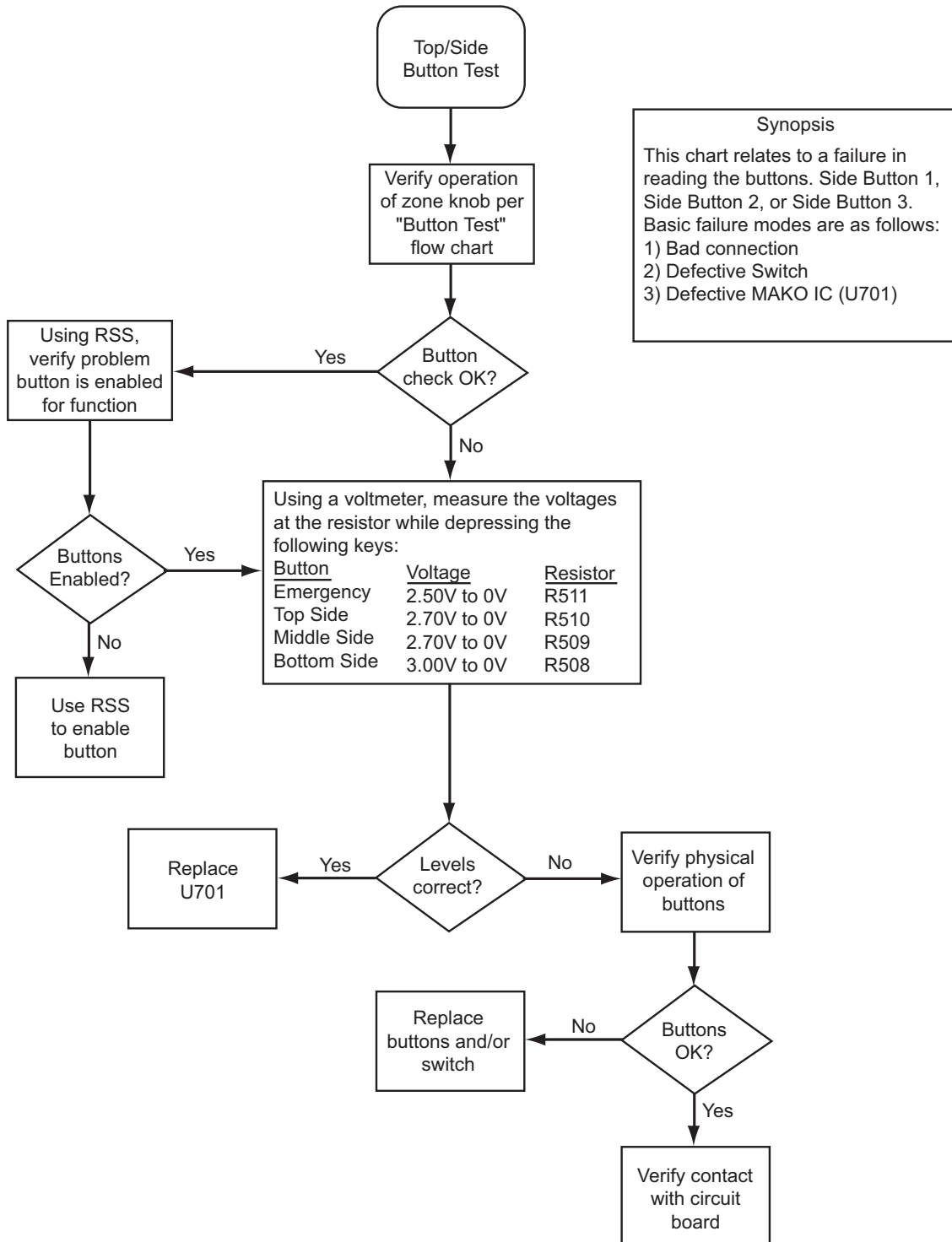

MAEPF-27338-O

6.4.14 No Display Troubleshooting Chart (1 of 3)

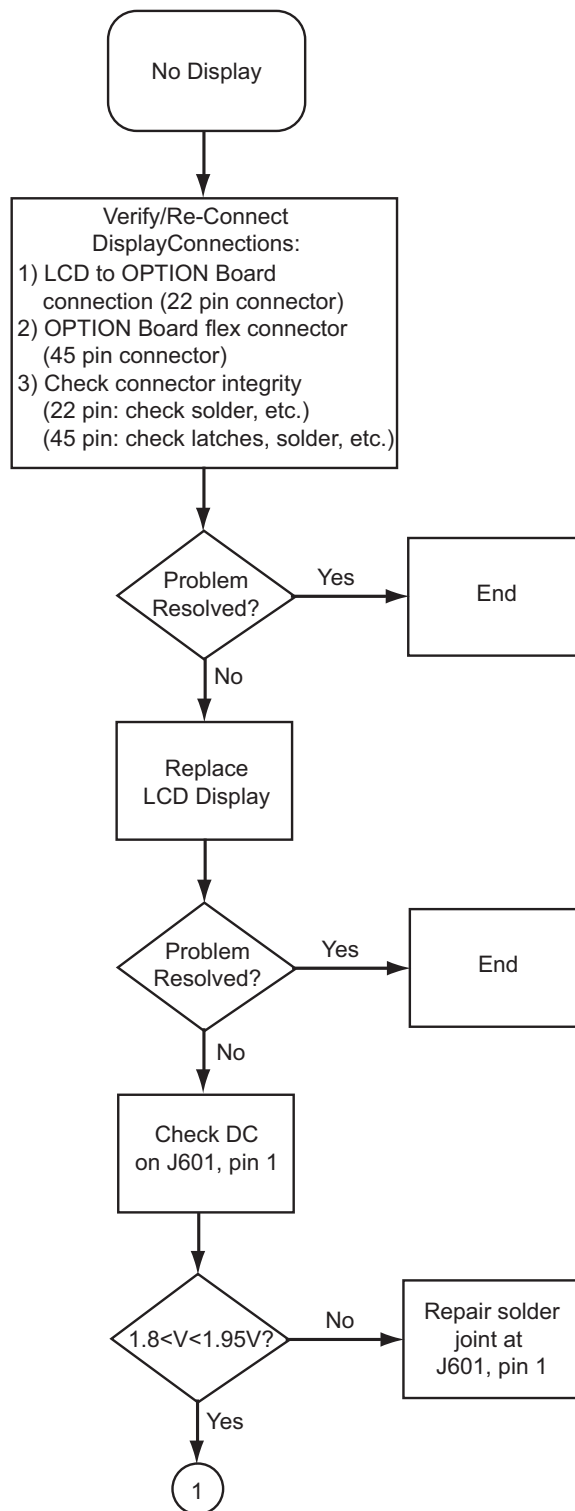

MAEPF-27339-O

6.4.15 No Display Troubleshooting Chart (2 of 3)

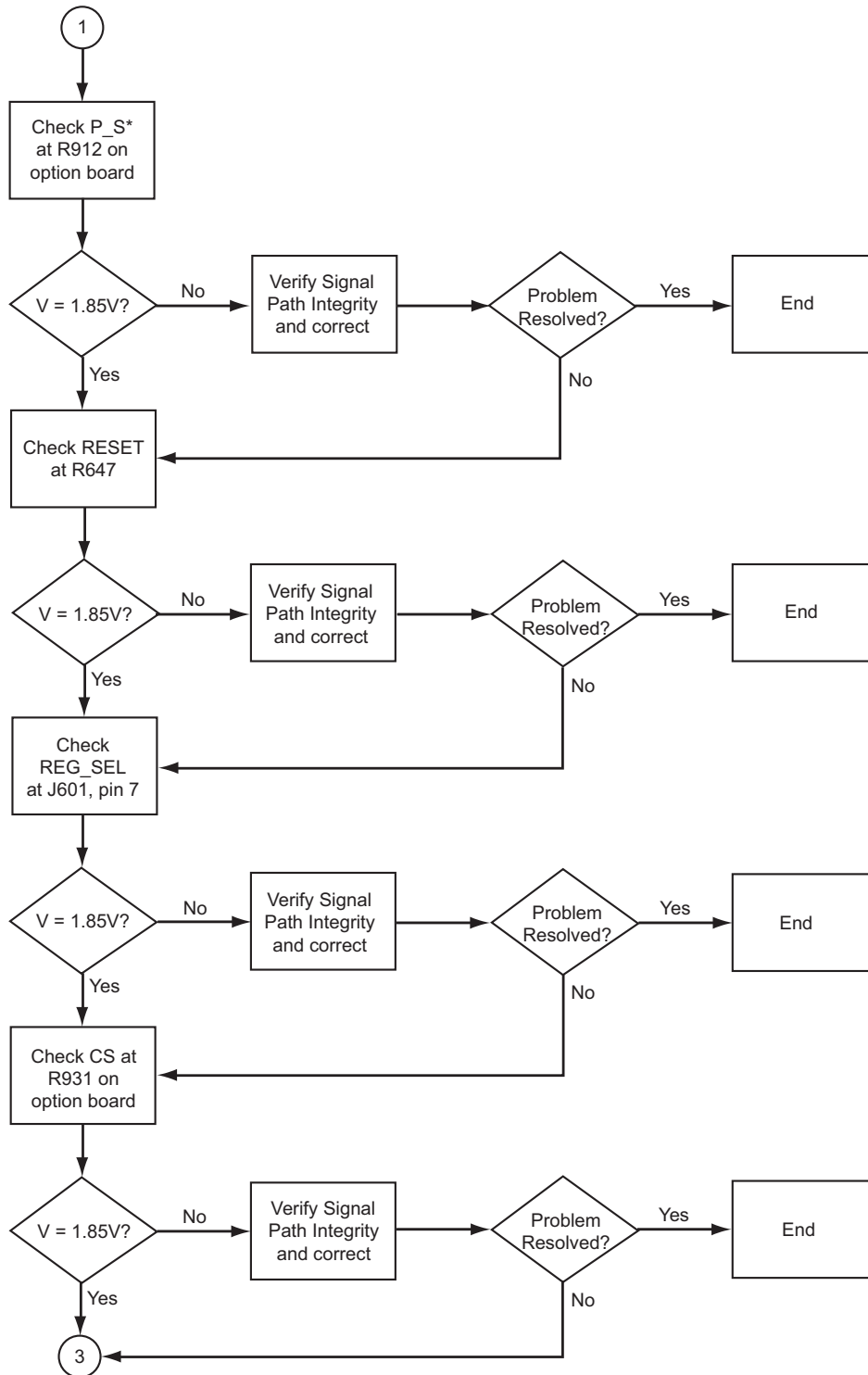

MAEPF-27340-O

6.4.16 No Display Troubleshooting Chart (3 of 3)

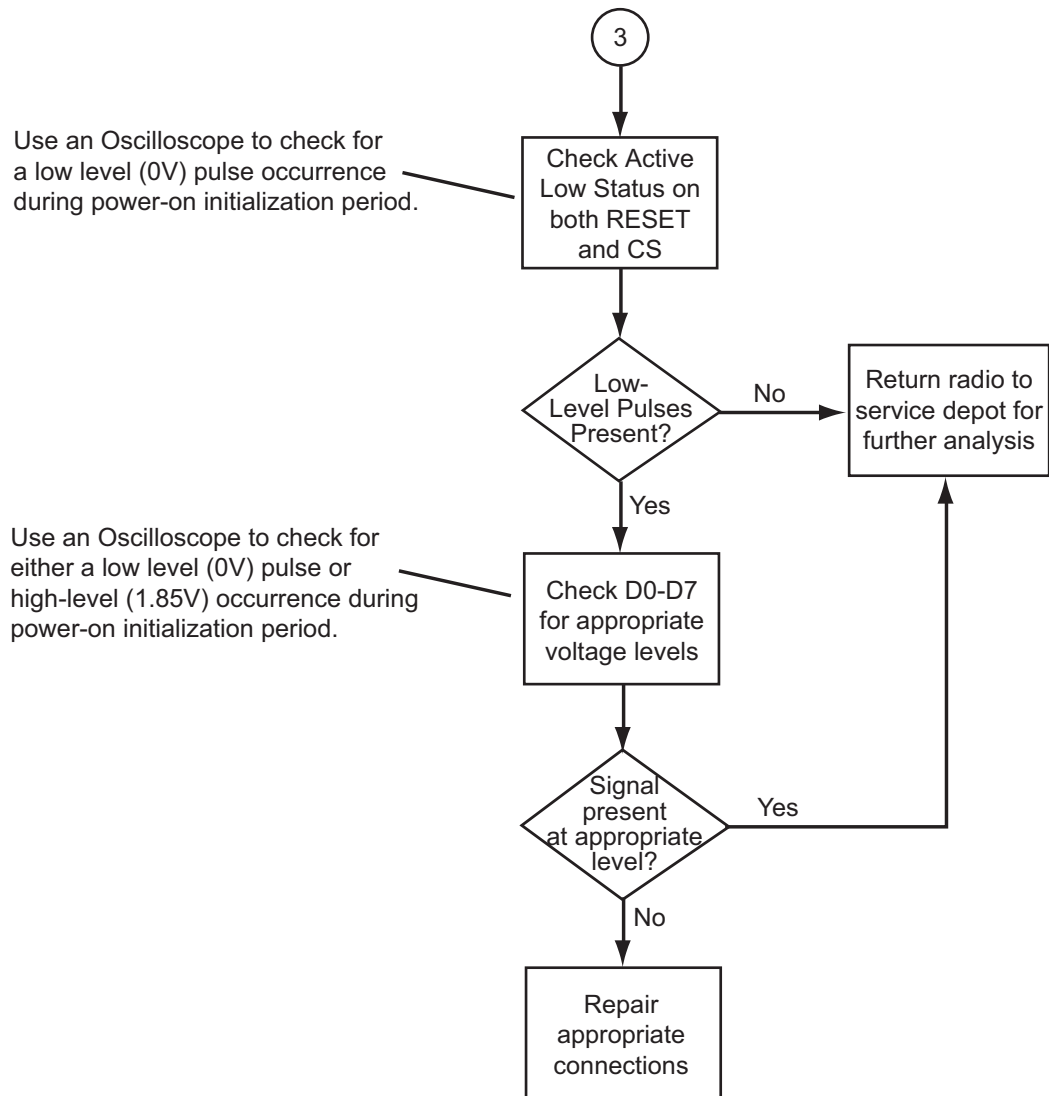

MAEPF-27341-O

6.4.17700/800 MHz Receive RF Troubleshooting Chart

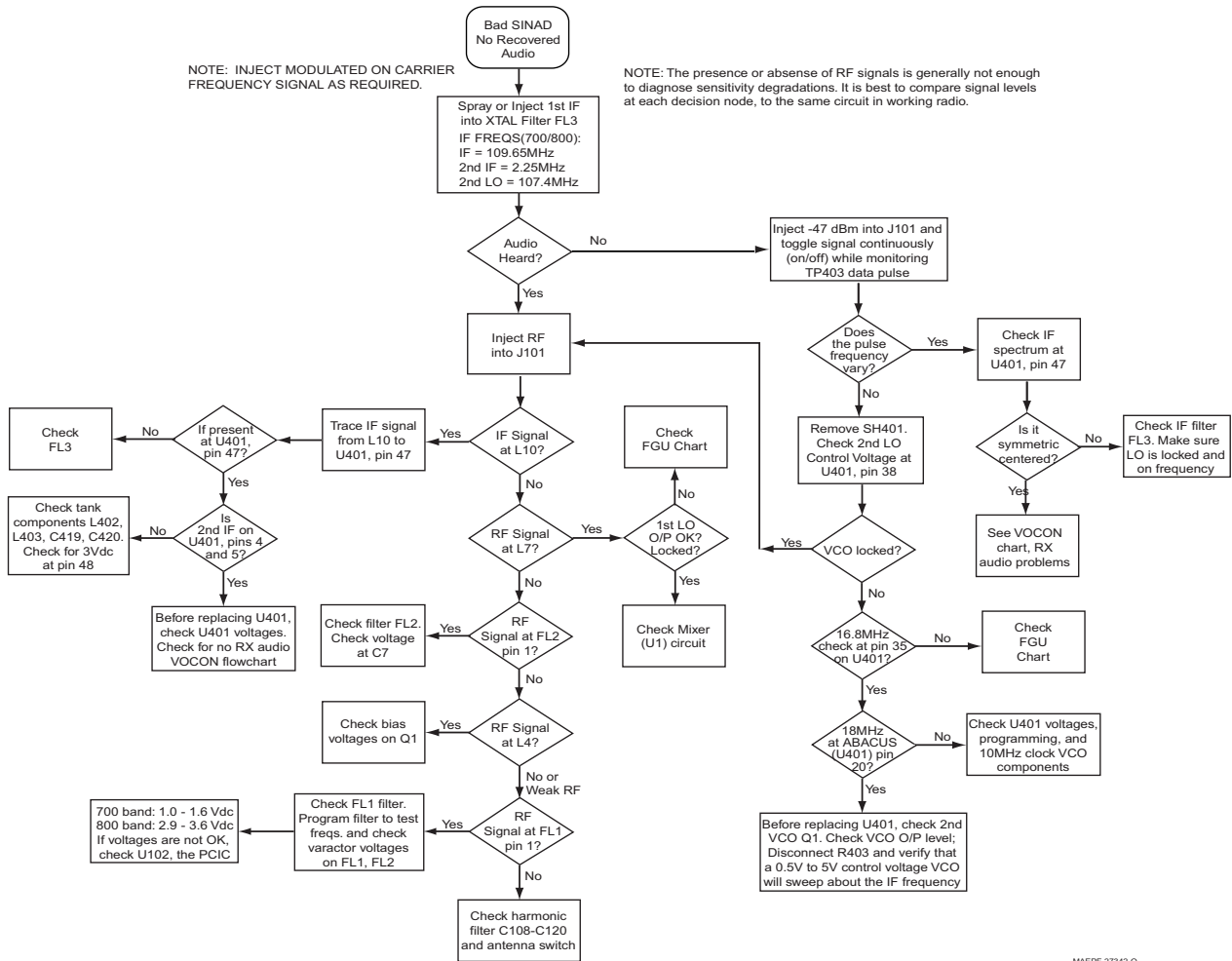

MAEPF-27342-O

6.4.18 VOCON Receive Audio Troubleshooting Chart

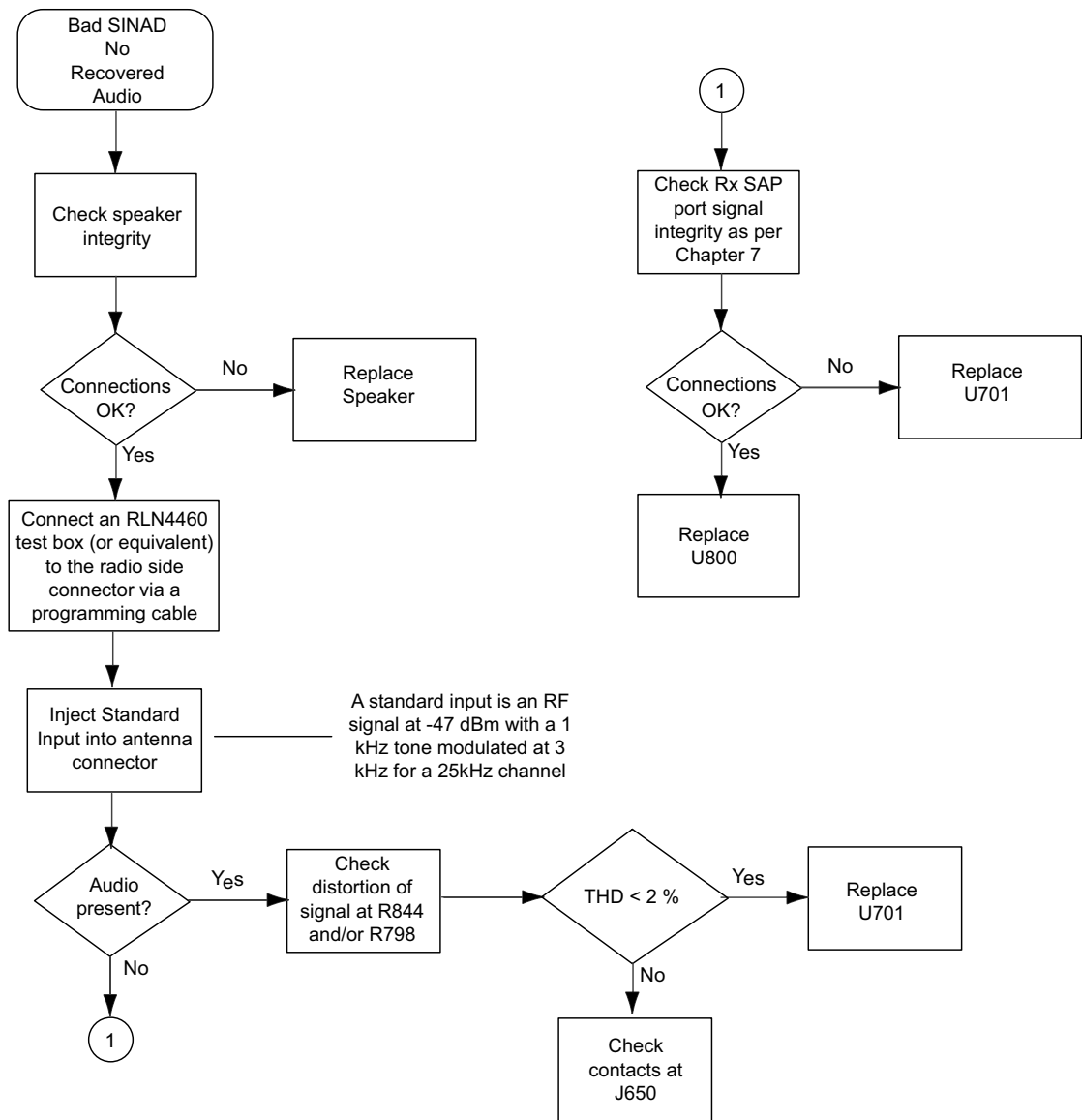

MAEPF-27347-O

6.4.19 700/800 MHz Frequency Generation Unit Troubleshooting Chart

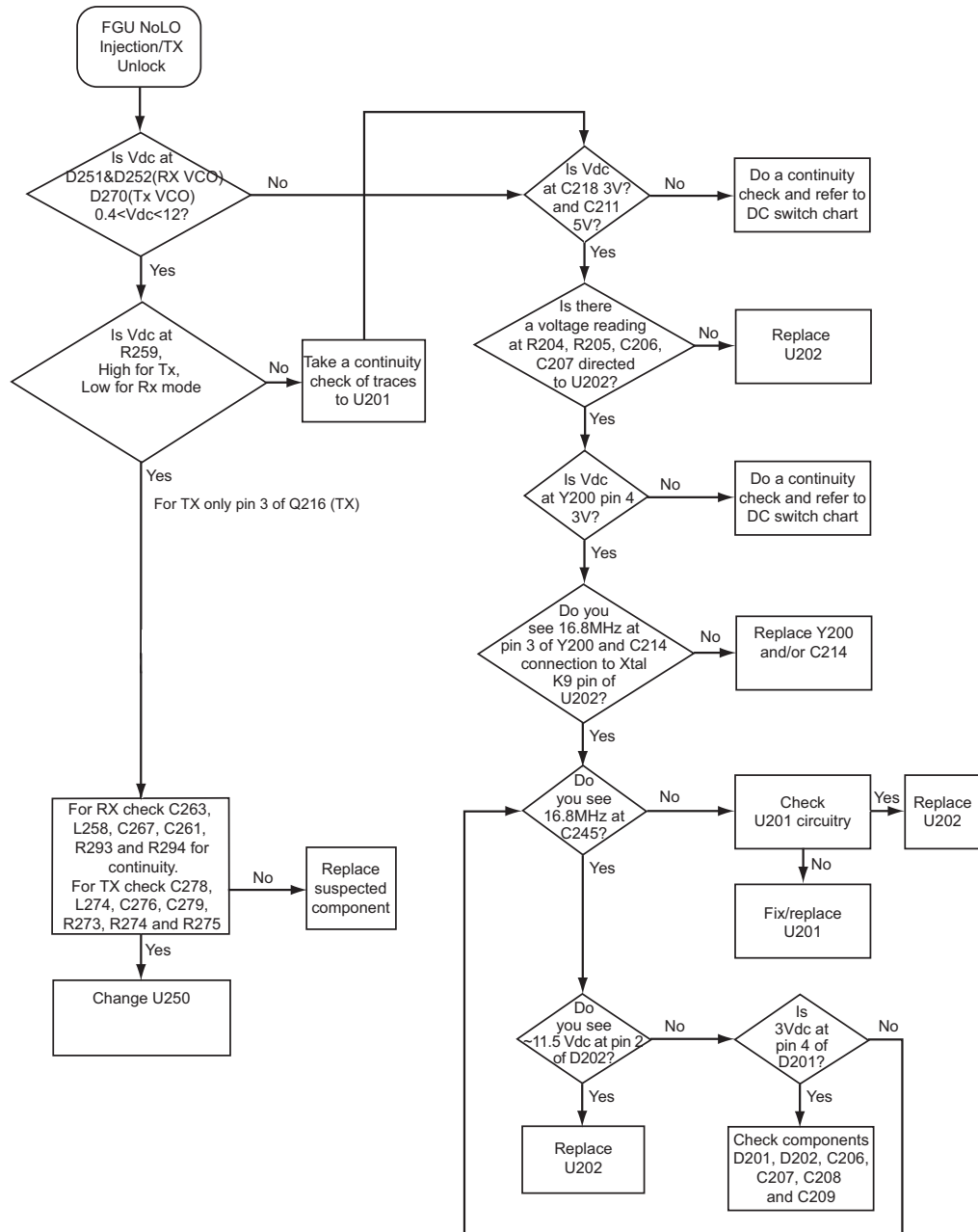

MAEPF-27346-O

6.4.20 VOCON Transmit Audio Troubleshooting Chart (1 of 2)

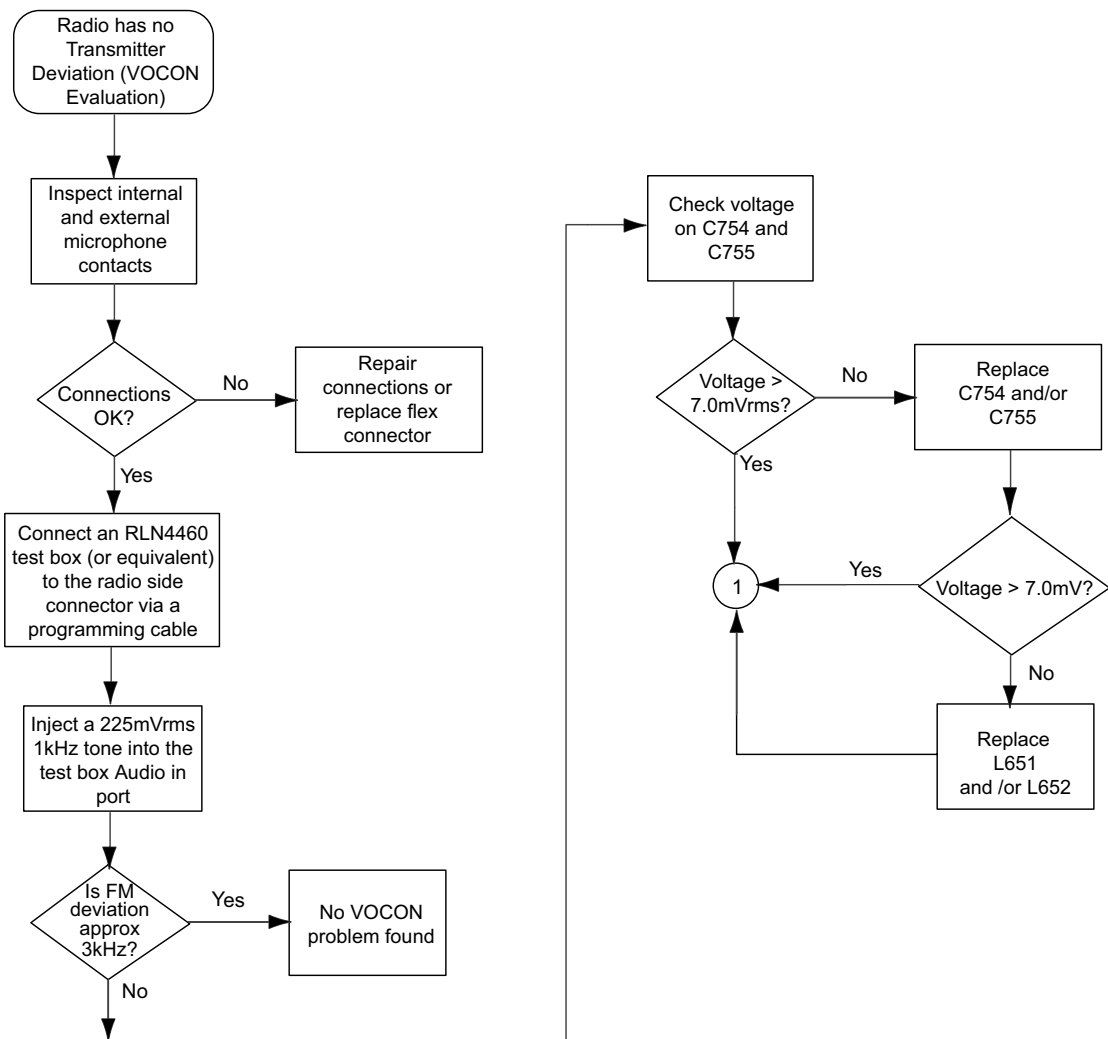

MAEPF-27347-O

6.4.21 VOCON Transmit Audio Troubleshooting Chart (2 of 2)

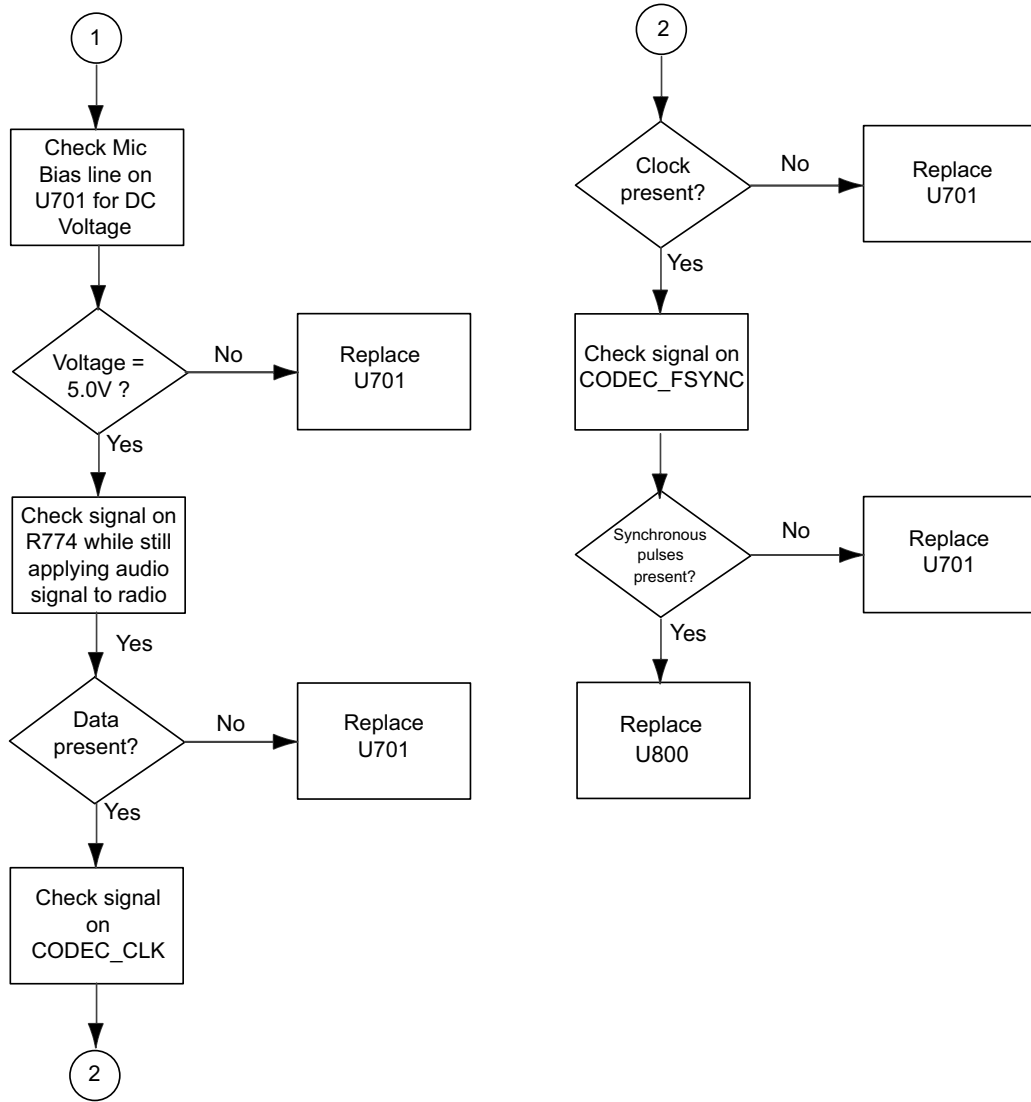

MAEPF-27334-O

6.4.22 No Transmit Deviation Troubleshooting Chart

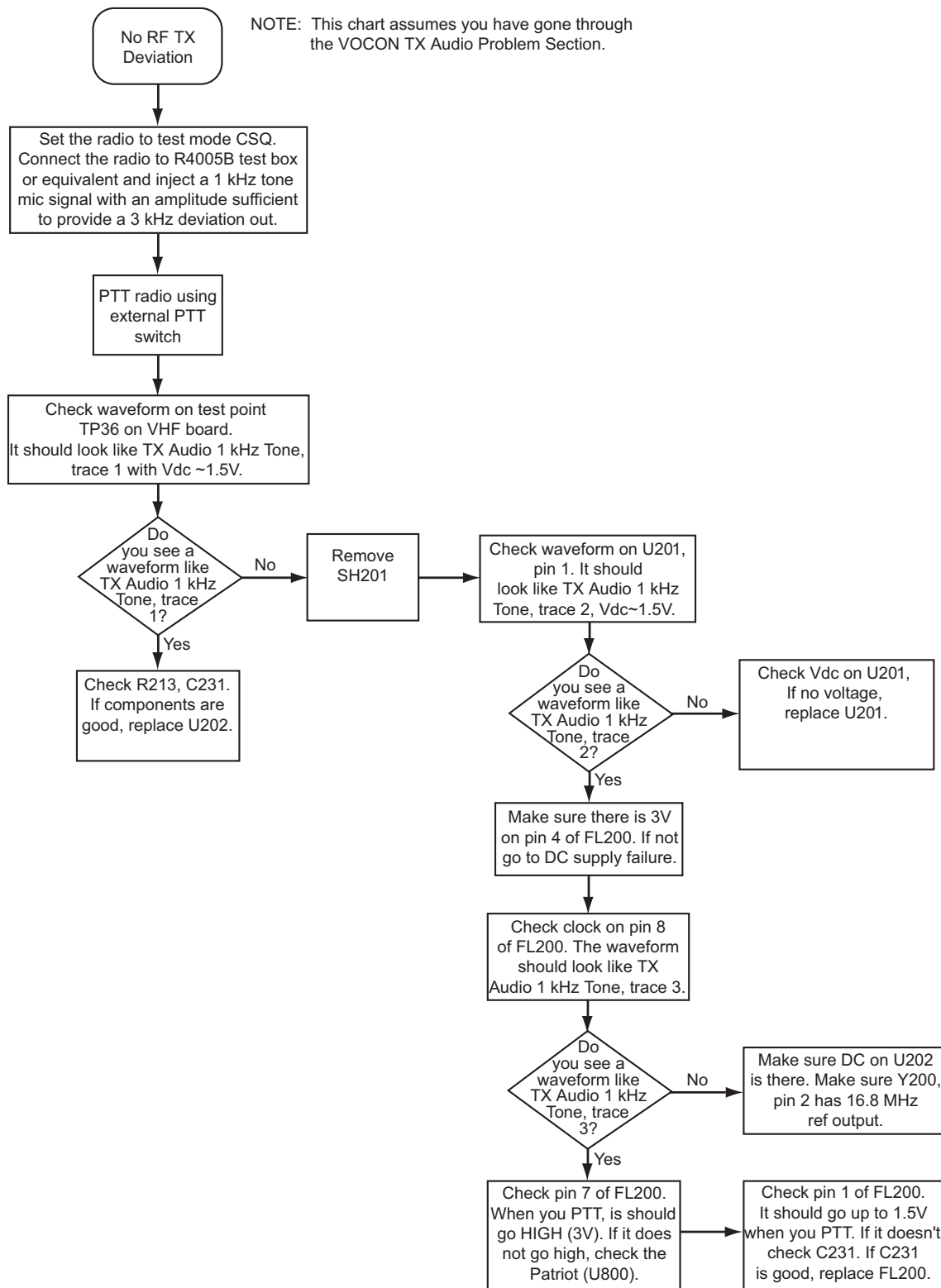

MAEPF-27343-O

6.4.23 700/800 MHz Transmitter RF Troubleshooting Chart

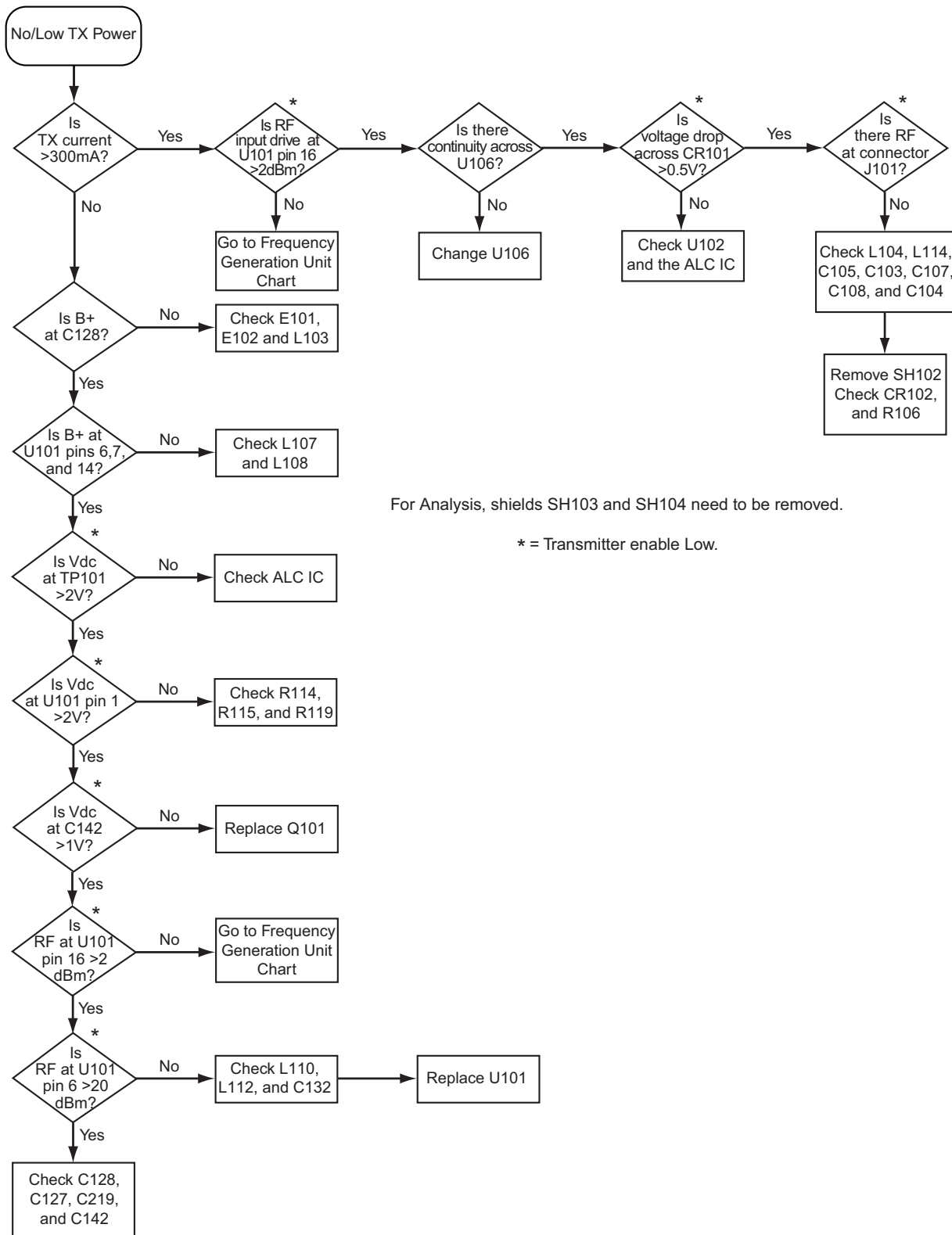

MAEPF-27349-O

6.4.24 Secure Hardware Failure

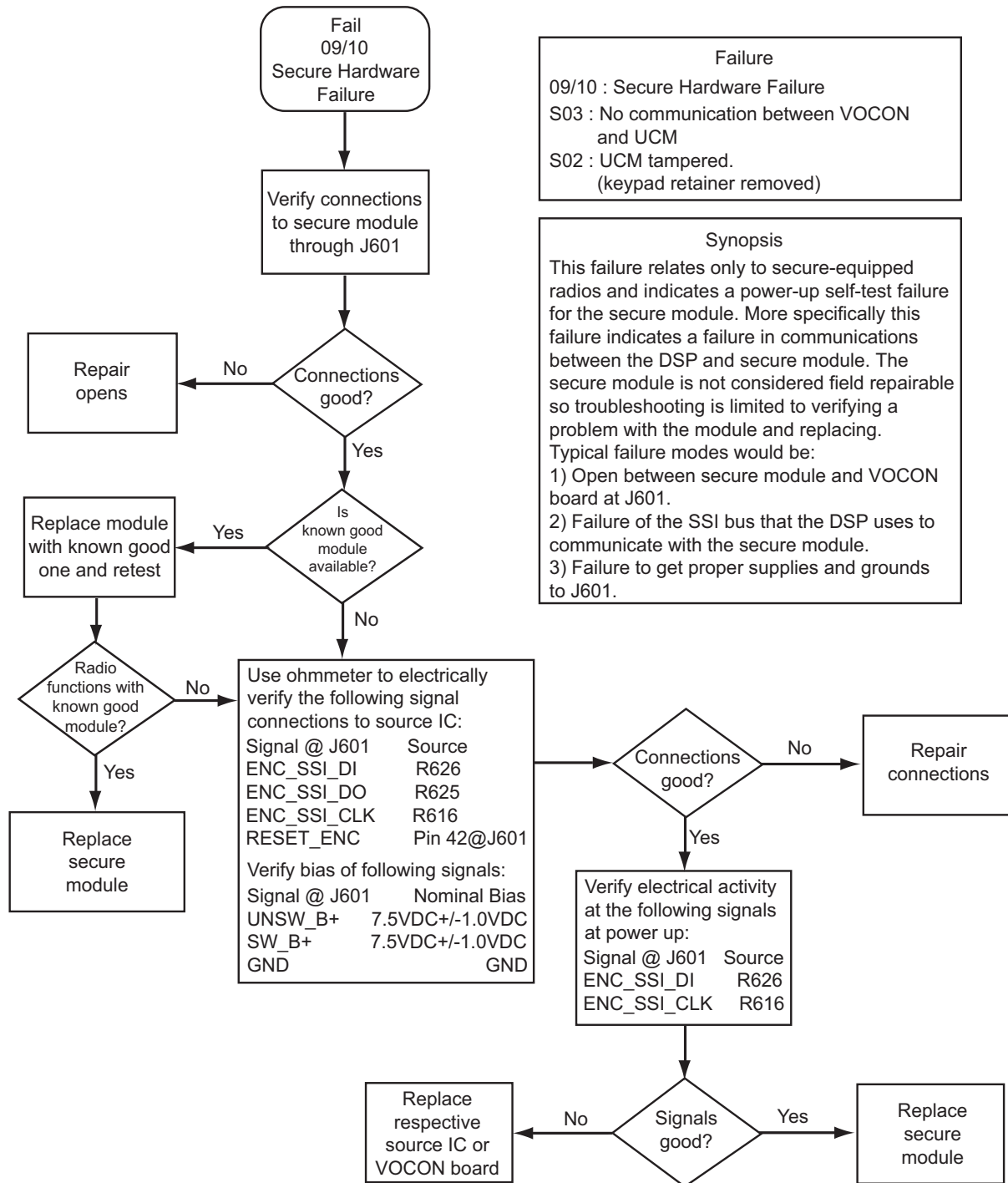

Failure
09/10 : Secure Hardware Failure
S03 : No communication between VOCON and UCM
S02 : UCM tampered.
(keypad retainer removed)

Synopsis
This failure relates only to secure-equipped radios and indicates a power-up self-test failure for the secure module. More specifically this failure indicates a failure in communications between the DSP and secure module. The secure module is not considered field repairable so troubleshooting is limited to verifying a problem with the module and replacing. Typical failure modes would be:
1) Open between secure module and VOCON board at J601.
2) Failure of the SSI bus that the DSP uses to communicate with the secure module.
3) Failure to get proper supplies and grounds to J601.

MAEPF-27387-O

Notes

Chapter 6.5 900 MHz Troubleshooting Charts

6.5.1 Introduction

This chapter contains detailed troubleshooting flowcharts. These flowcharts are for use as a guide in determining the problem areas. They are not a substitute for the knowledge of circuit operation and astute troubleshooting techniques. It is advisable to refer to the related detailed circuit descriptions in the theory sections prior to troubleshooting a radio.

This manual is to be used in conjunction with the ASTRO XTS 2500/XTS 2500I Digital Portable Radios Basic Service Manual (Motorola part number 6816984H01), which uses the pass/fail service approach to radio problems.

6.5.2 List of Troubleshooting Flowcharts

Most troubleshooting flowcharts end up by pointing to an IC to replace. **It is not always noted, but it is good practice to verify supplies and grounds to the affected IC and to trace continuity to the malfunctioning signal and related circuitry before replacing any IC.** For instance, if a clock signal is not available at a destination IC, continuity from the source IC should be checked before replacing the source IC

Table 6.5-1. List of Troubleshooting Flowcharts

Chart Name	Page No.
900 MHz Radio Main Troubleshooting Chart	6.5-2
Radio Power-Up Fail Troubleshooting Chart	6.5-3
DC Supply Fail Troubleshooting Chart	6.5-6
Button Test Troubleshooting Chart	6.5-9
Volume Set Error Troubleshooting Chart	6.5-10
Volume Set Error Troubleshooting Chart	6.5-11
Top/Side Button Error Troubleshooting Chart	6.5-12
No Display Troubleshooting Chart	6.5-13
900 MHz Receive RF Troubleshooting Chart	6.5-16
VOCON Receive Audio Troubleshooting Chart	6.5-17
900 MHz Frequency Generation Unit Troubleshooting Chart	6.5-18
VOCON Transmit Audio Troubleshooting Chart	6.5-19
No Transmit Deviation Troubleshooting Chart	6.5-21
900MHz Transmitter RF Troubleshooting Chart	6.5-22
Secure Hardware Failure	6.5-23

NOTE: μC is used in several of the following troubleshooting charts.
 μC = microcontroller unit (MCU).

6.5.3 900 MHz Radio Main Troubleshooting Chart

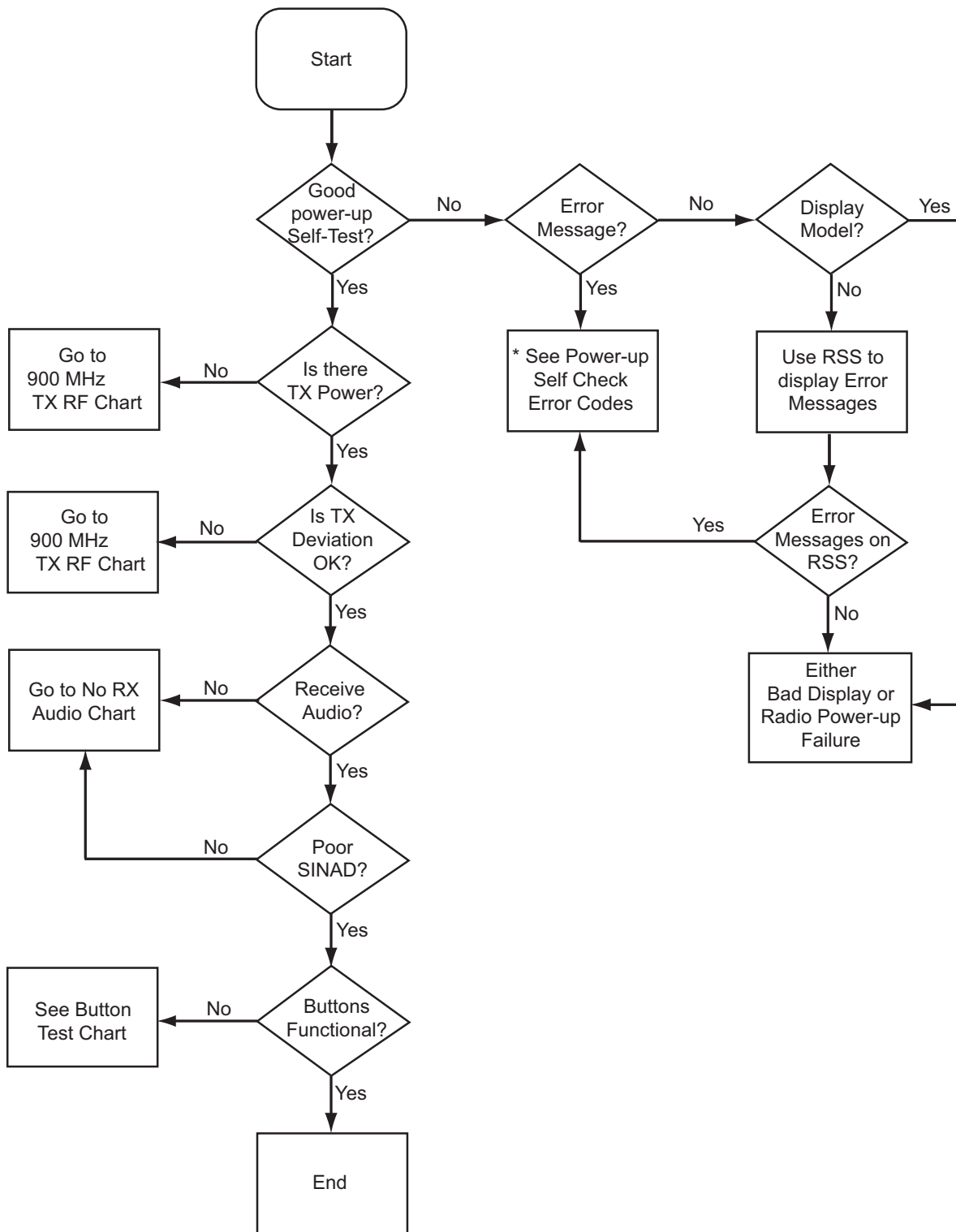

*Please see Table 5-2 on page 5-3.

6.5.4 Radio Power-Up Fail Troubleshooting Chart (1 of 3)

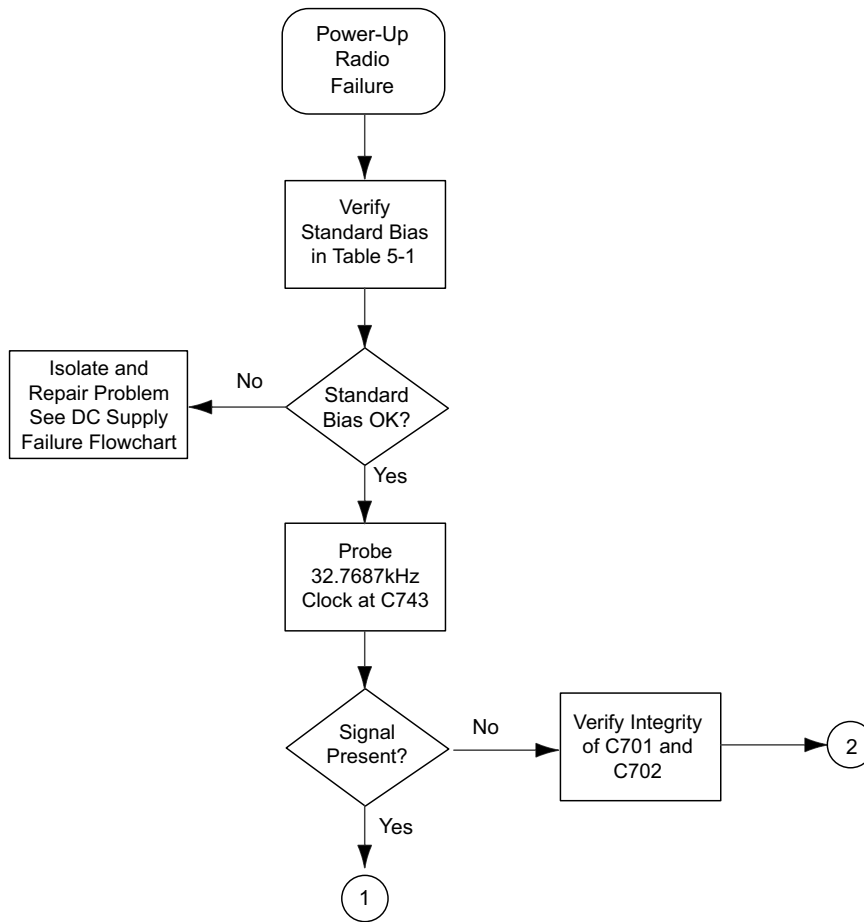

6.5.5 Radio Power-Up Fail Troubleshooting Chart (2 of 3)

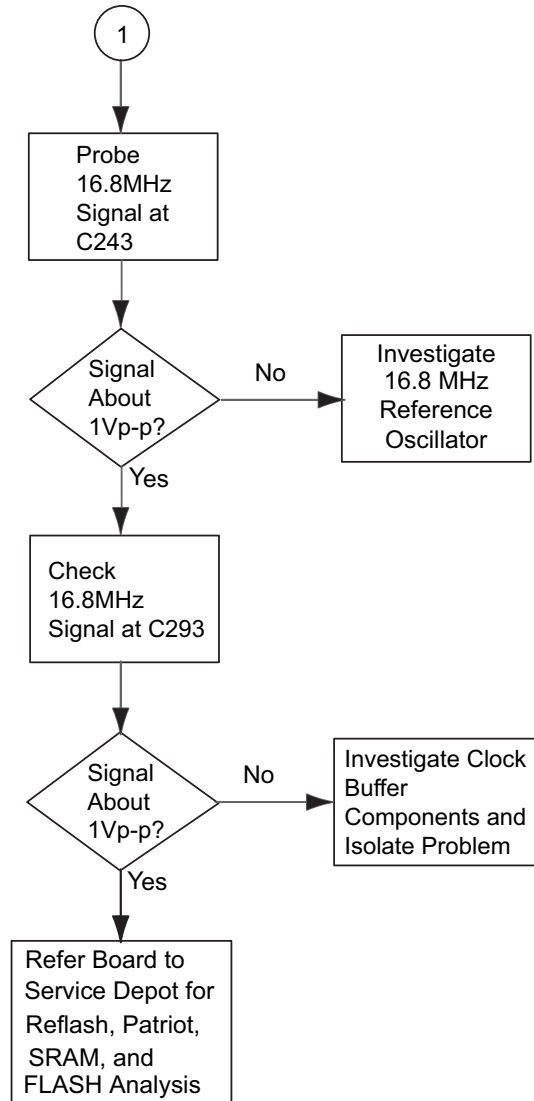

6.5.6 Radio Power-Up Fail Troubleshooting Chart (3 of 3)

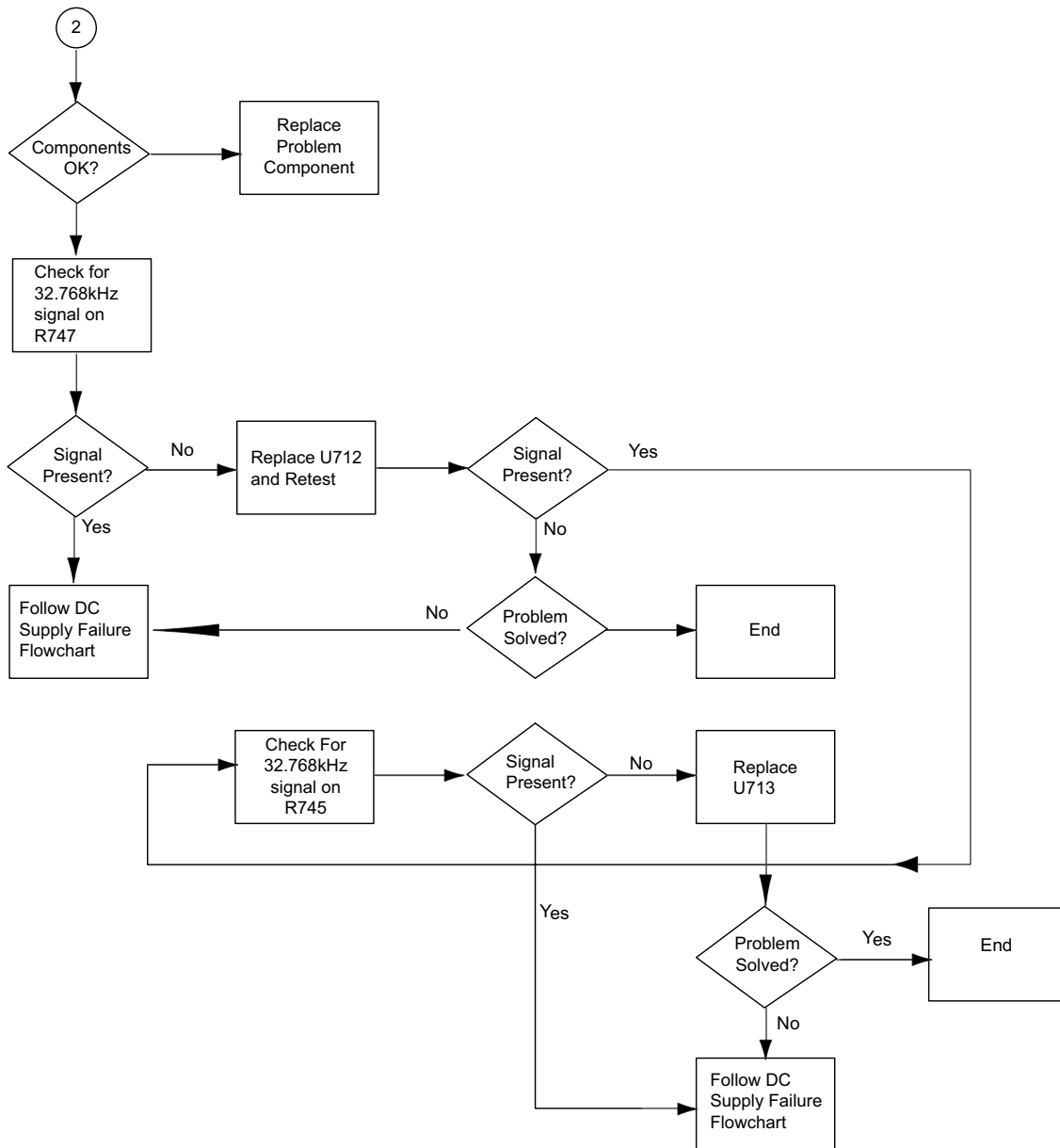

MAEPF-27333-O

6.5.7 DC Supply Fail Troubleshooting Chart (1 of 3)

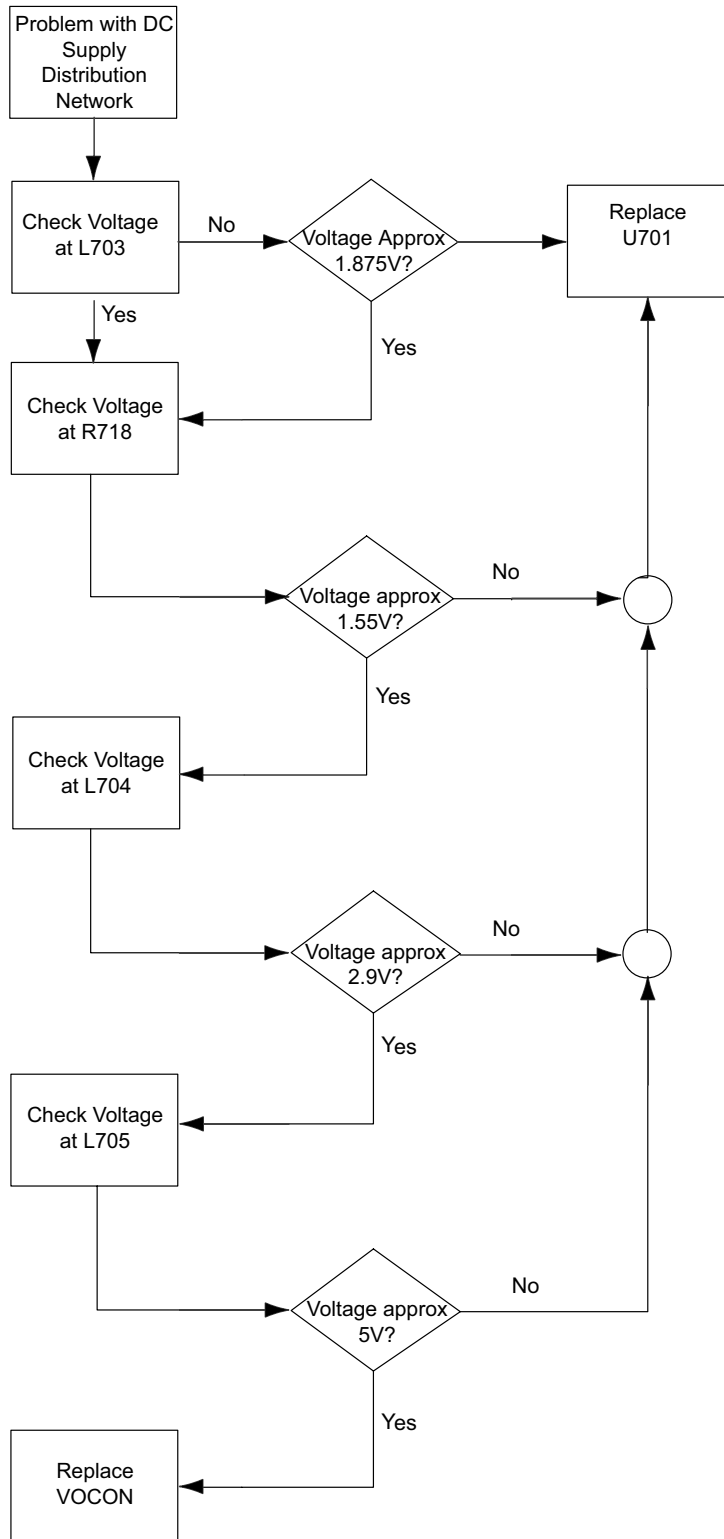

MAEPF-27334-O

6.5.8 DC Supply Fail Troubleshooting Chart (2 of 3)

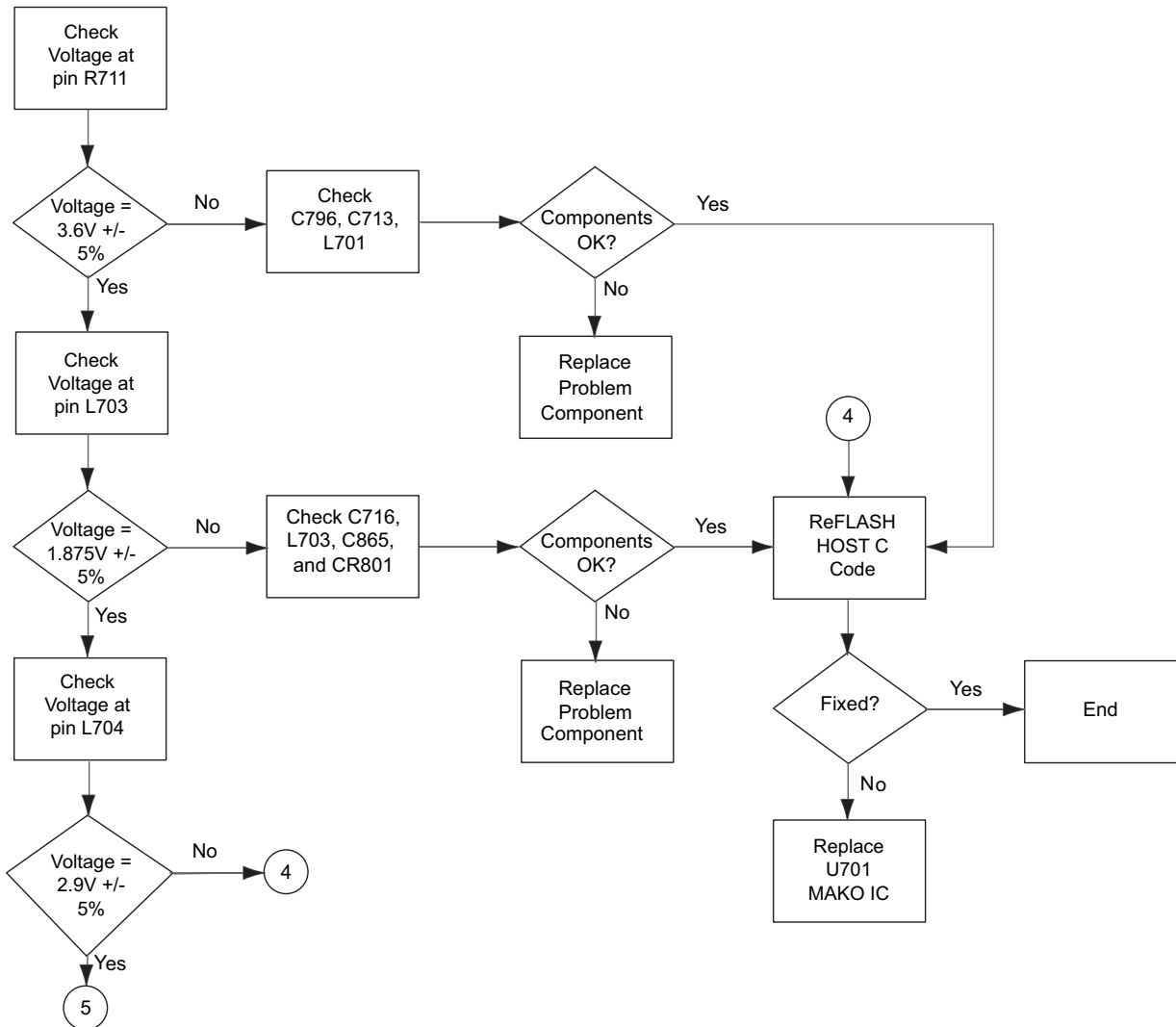

MAEPF-27333-O

6.5.9 DC Supply Fail Troubleshooting Chart (3 of 3)

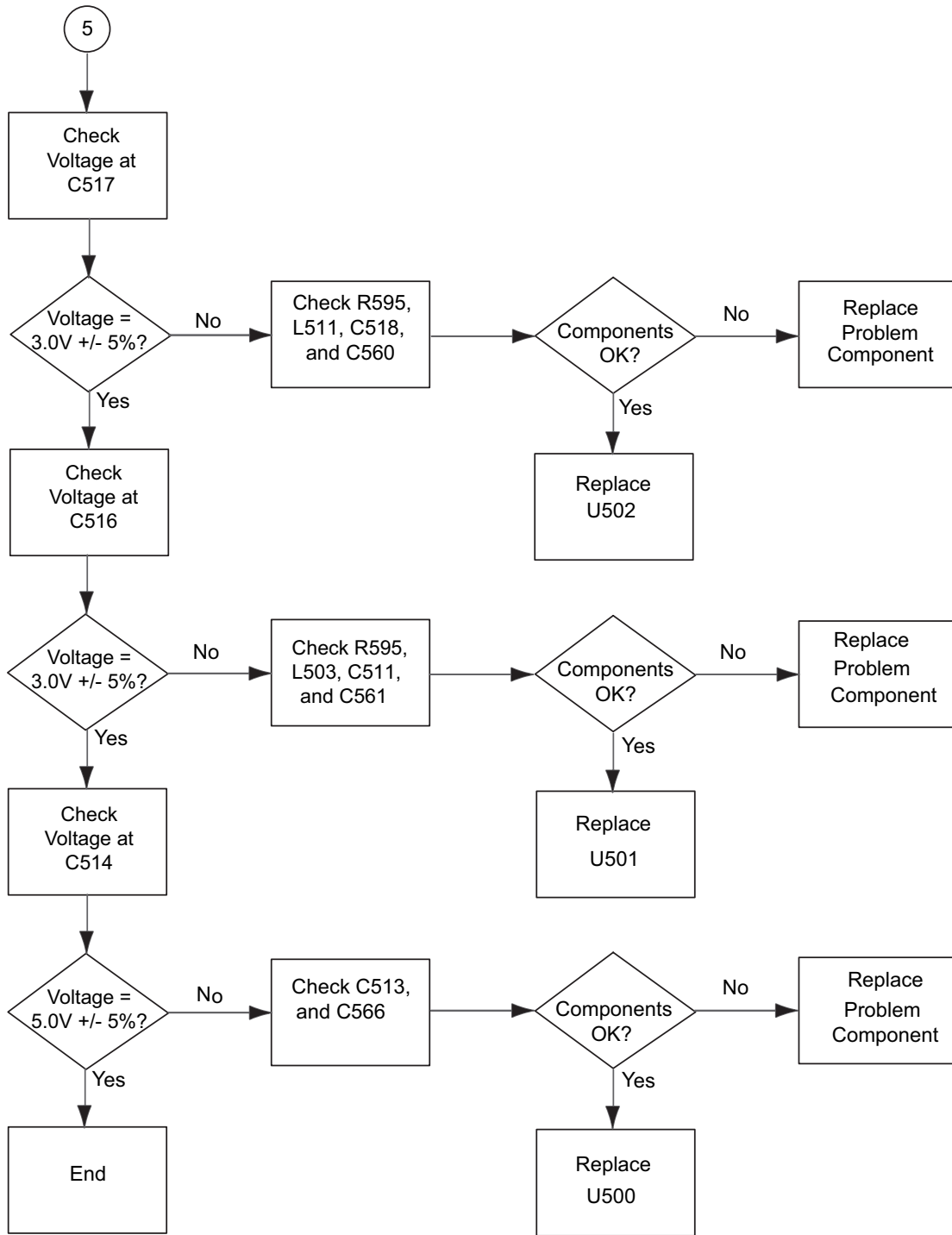

6.5.10 Button Test Troubleshooting Chart

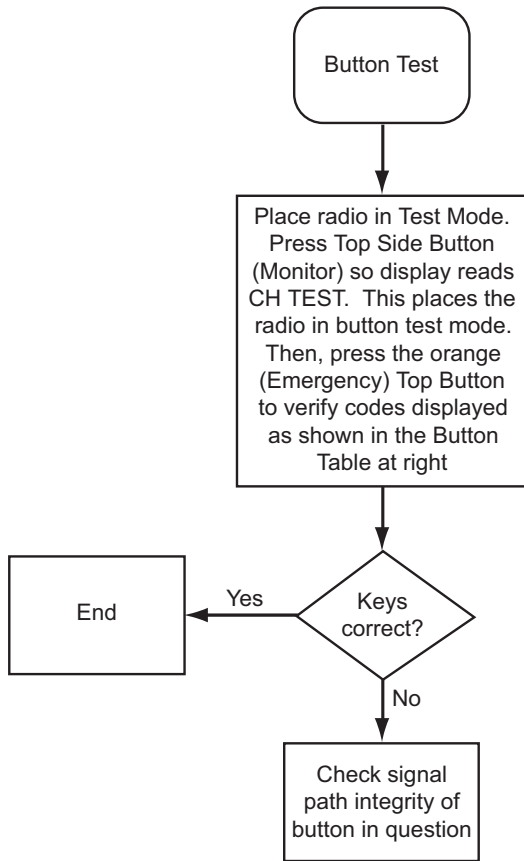

Synopsis

This chart relates to a failure in the button functions. Basic Failure modes are as follows:

- 1) Failure in keypad flex assembly.
- 2) Bad Connection
- 3) Defective Switches or pads
- 4) Defective MAKO IC (U701)

Button Table

Button	Code	Chart
PTT	1/ 0-1	
Top Button (Emergency)	3/ 0-1	C.6
Side Button 1 (Monitor)	96/ 0-1	C.6
Side Button 2	97/ 0-1	C.6
Side Button 3	98/ 0-1	C.6
Channel Select (Frequency)	4/ 0-15	C.8
Volume Control Knob	0/ 0-220	C.7
Zone Select	65/ 0-2	C.8

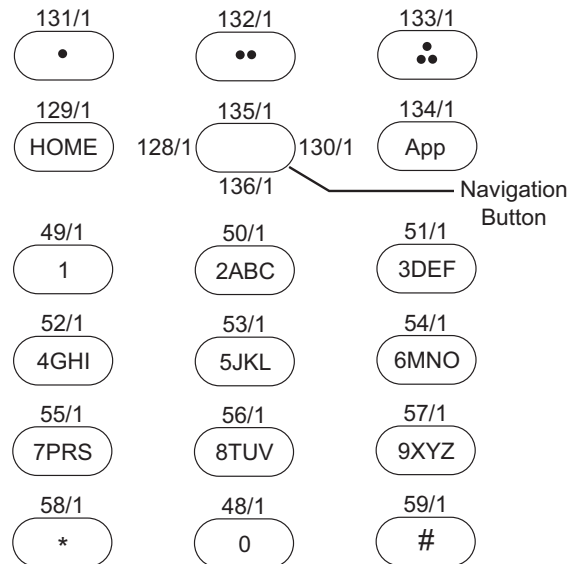

MAEPF-27335-O

6.5.11 Volume Set Error Troubleshooting Chart

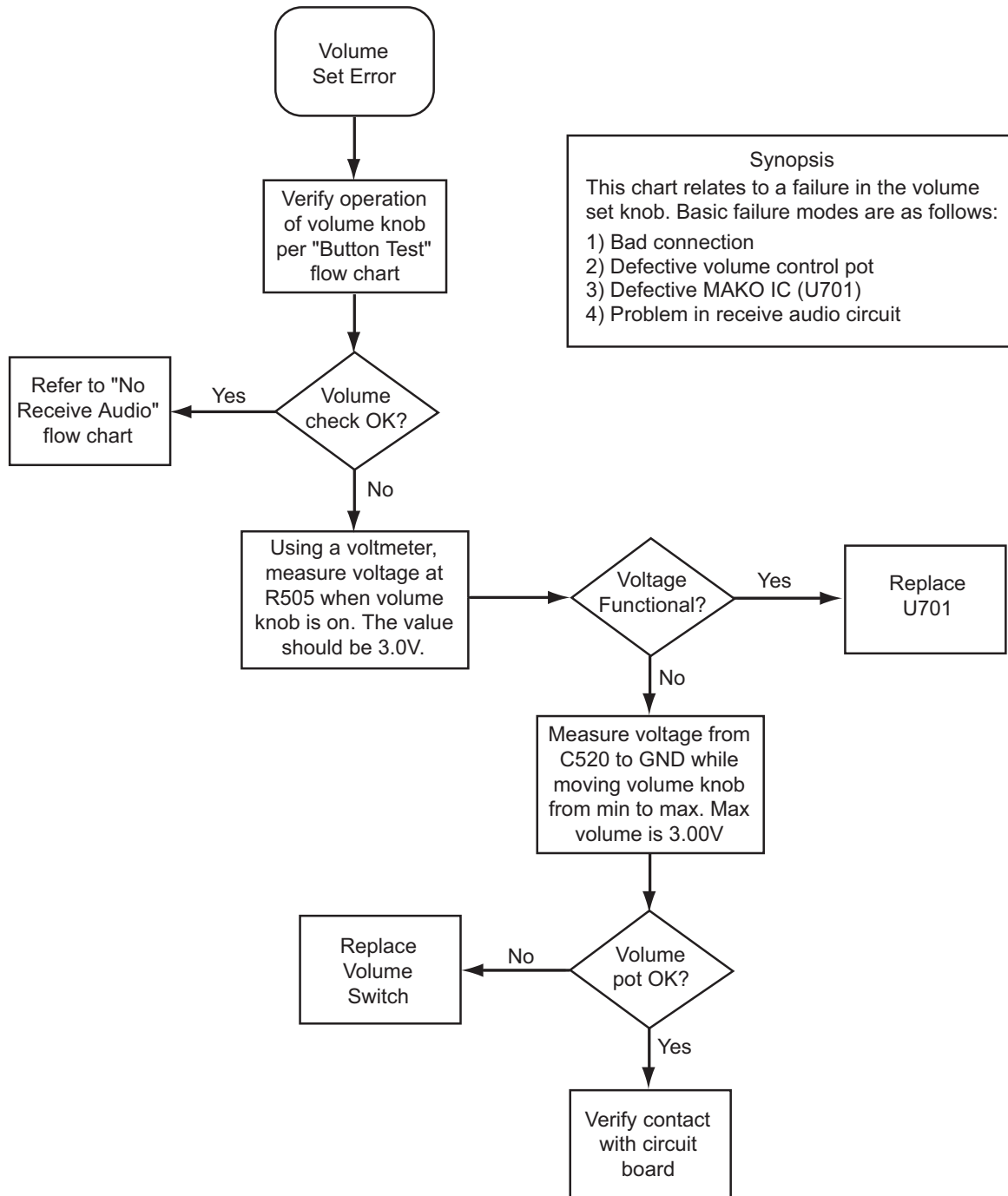

Synopsis

This chart relates to a failure in the volume set knob. Basic failure modes are as follows:

- 1) Bad connection
- 2) Defective volume control pot
- 3) Defective MAKO IC (U701)
- 4) Problem in receive audio circuit

MAEPF-27336-O

6.5.12 Zone/Channel Select Error Troubleshooting Chart

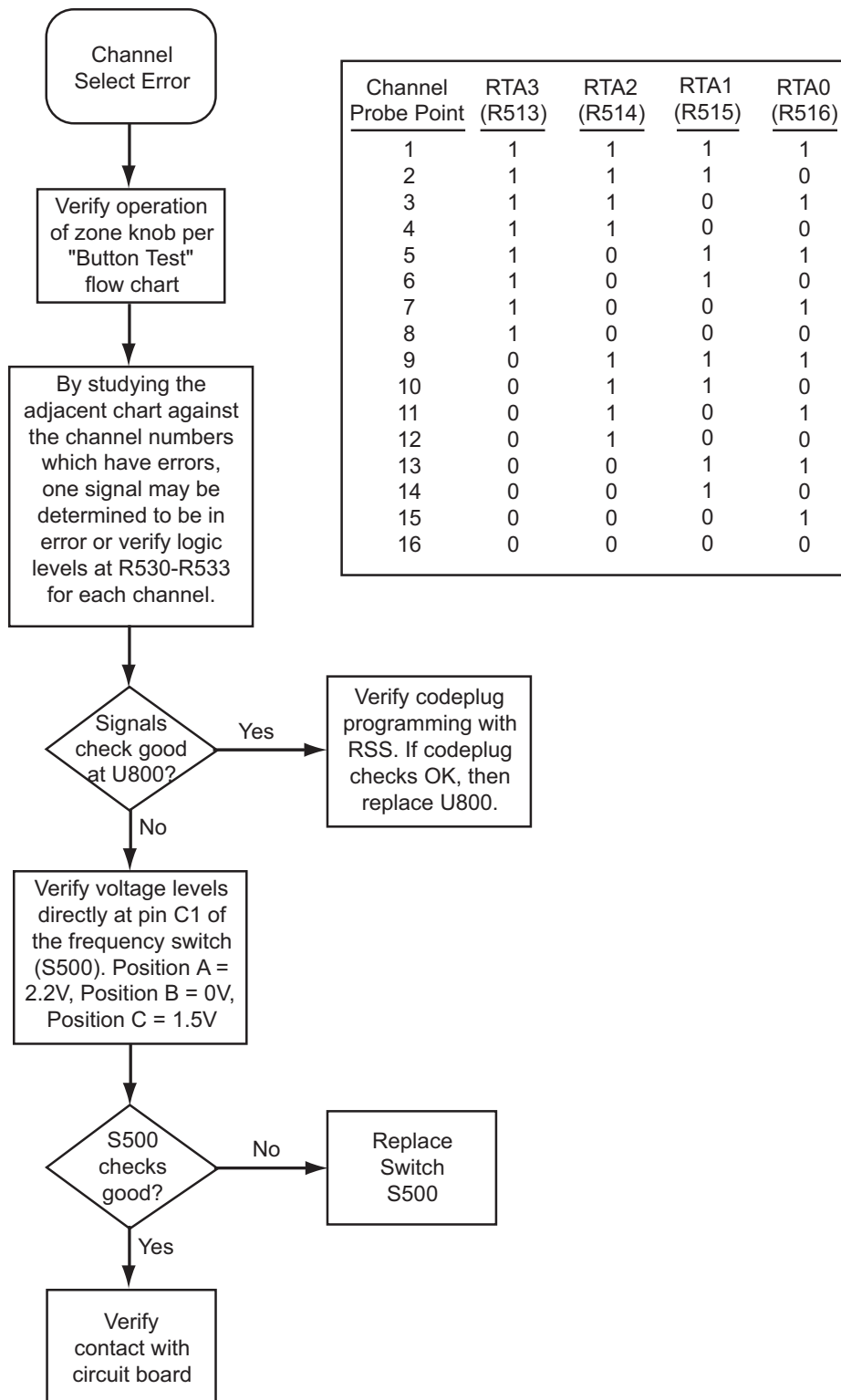

MAEPF-27337-O

6.5.13 Top/Side Button Error Troubleshooting Chart

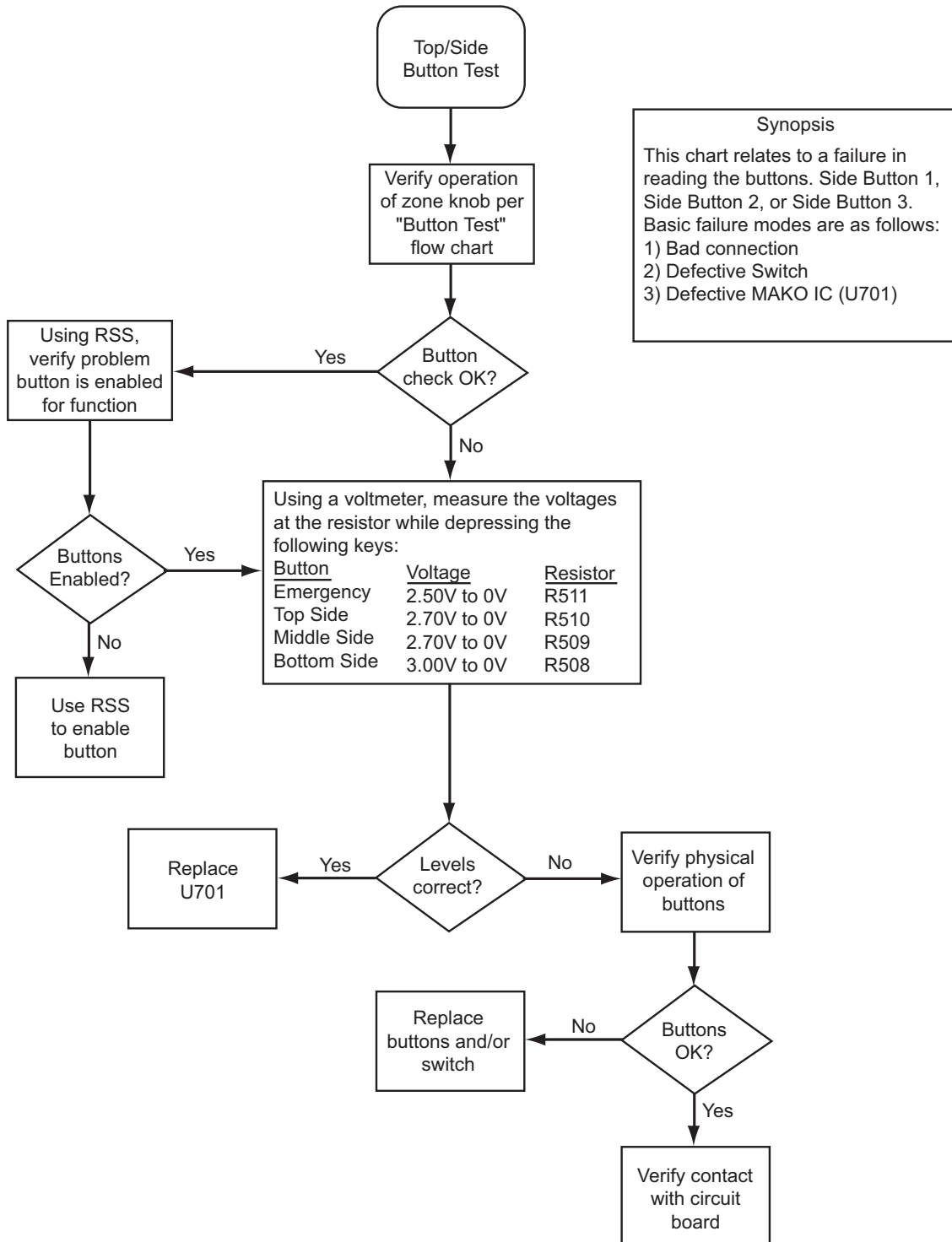

MAEPF-27338-O

6.5.14 No Display Troubleshooting Chart (1 of 3)

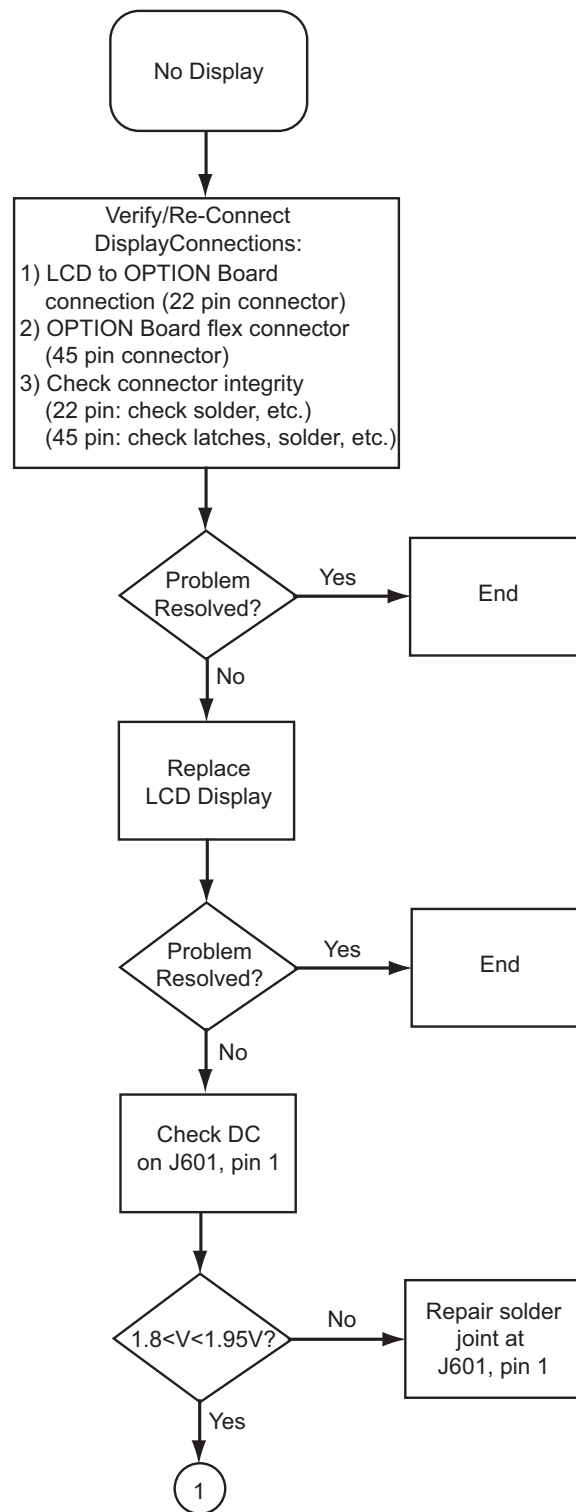

MAEPF-27339-O

6.5.15 No Display Troubleshooting Chart (2 of 3)

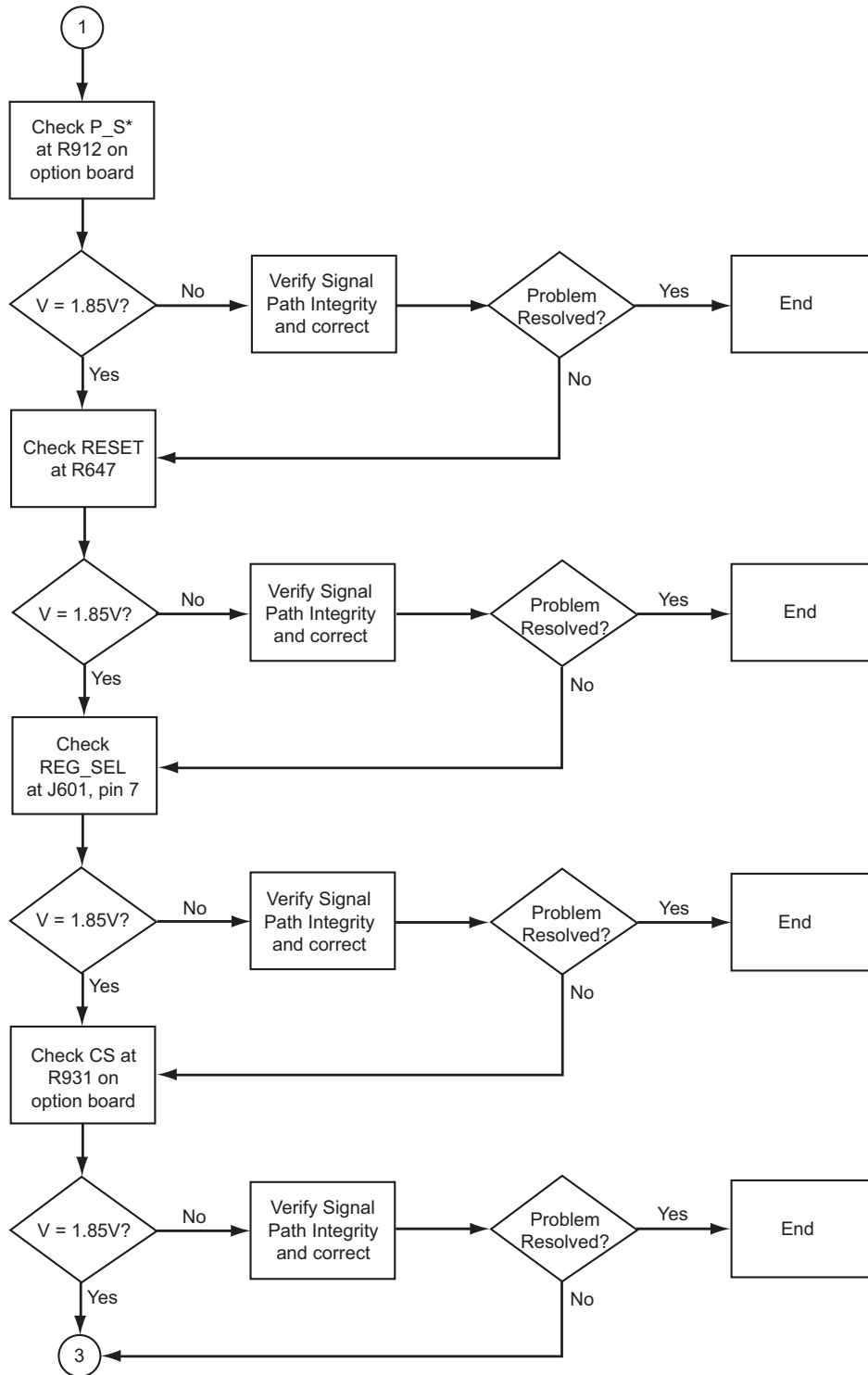

MAEPF-27340-O

6.5.16 No Display Troubleshooting Chart (3 of 3)

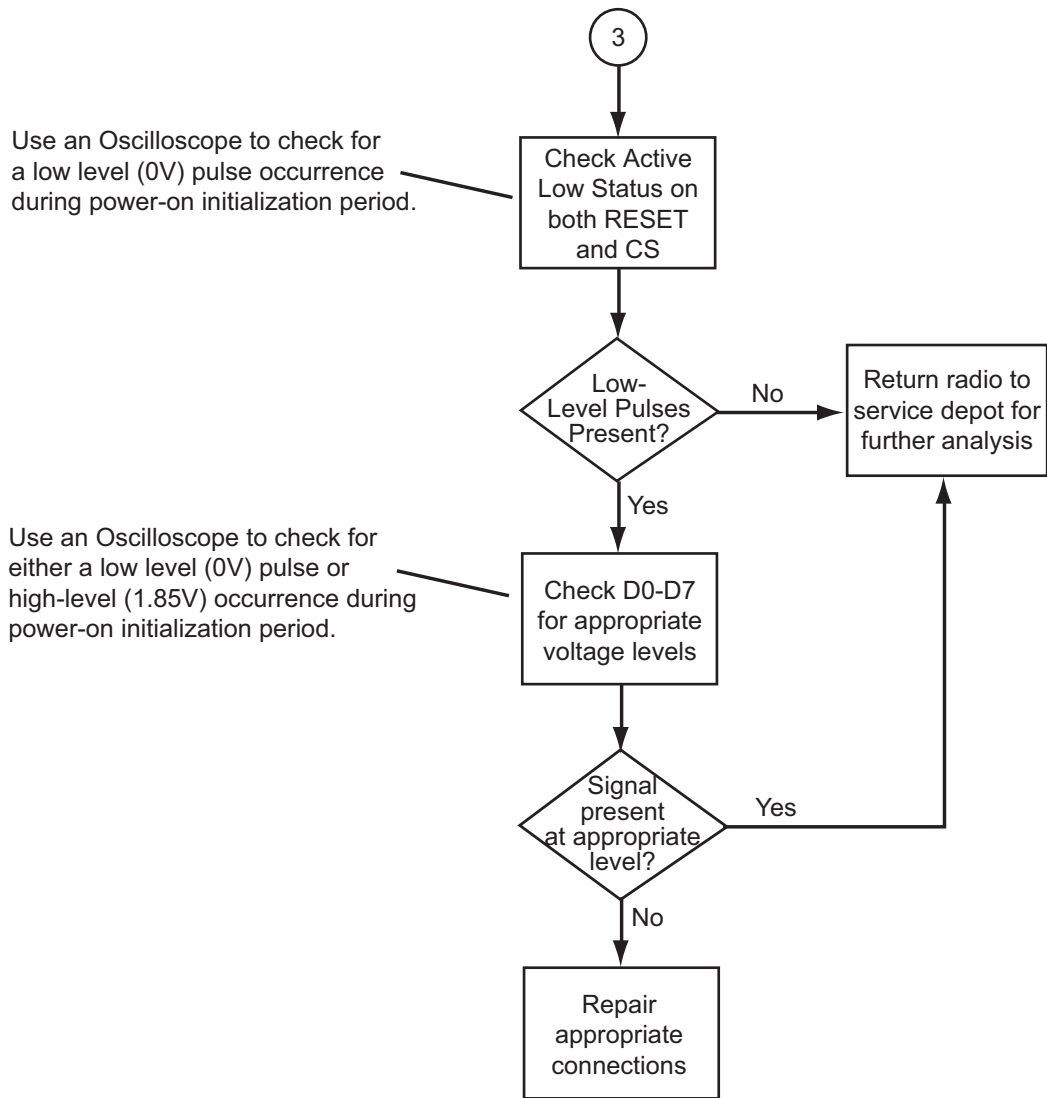

MAEPF-27341-O

6.5.17900 MHz Receive RF Troubleshooting Chart

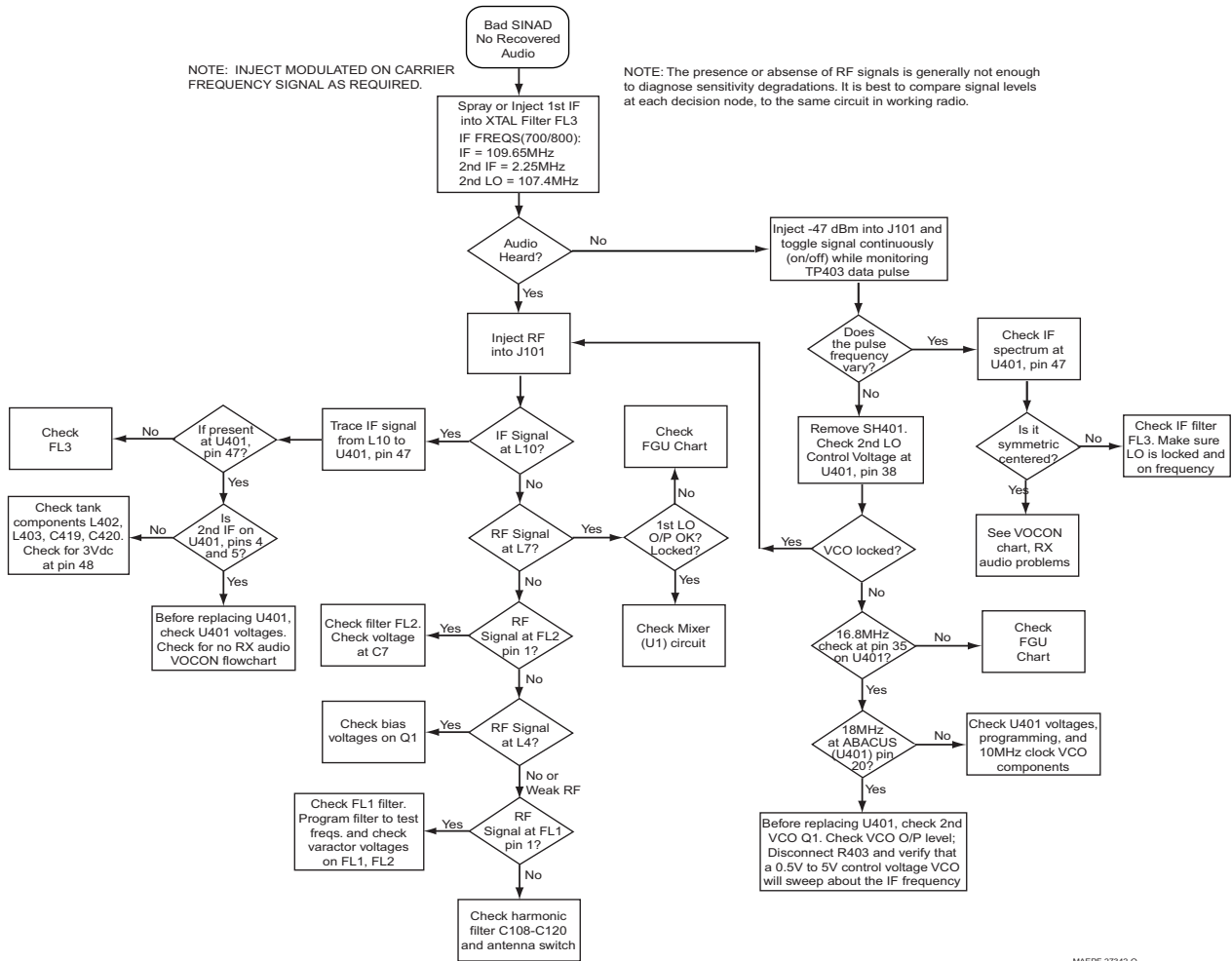

MAEPF-27342-O

6.5.18 VOCON Receive Audio Troubleshooting Chart

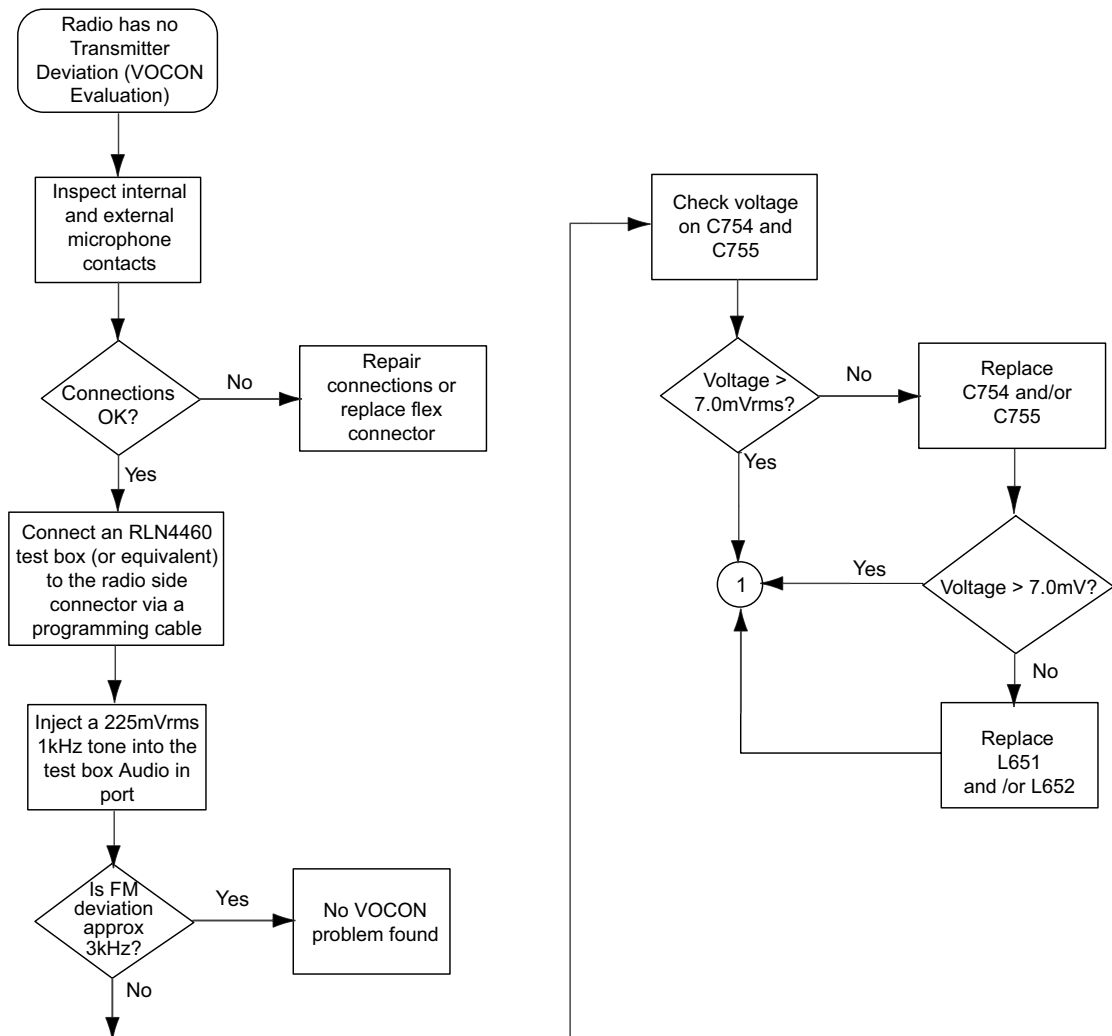

MAEPF-27347-O

6.5.19900 MHz Frequency Generation Unit Troubleshooting Chart

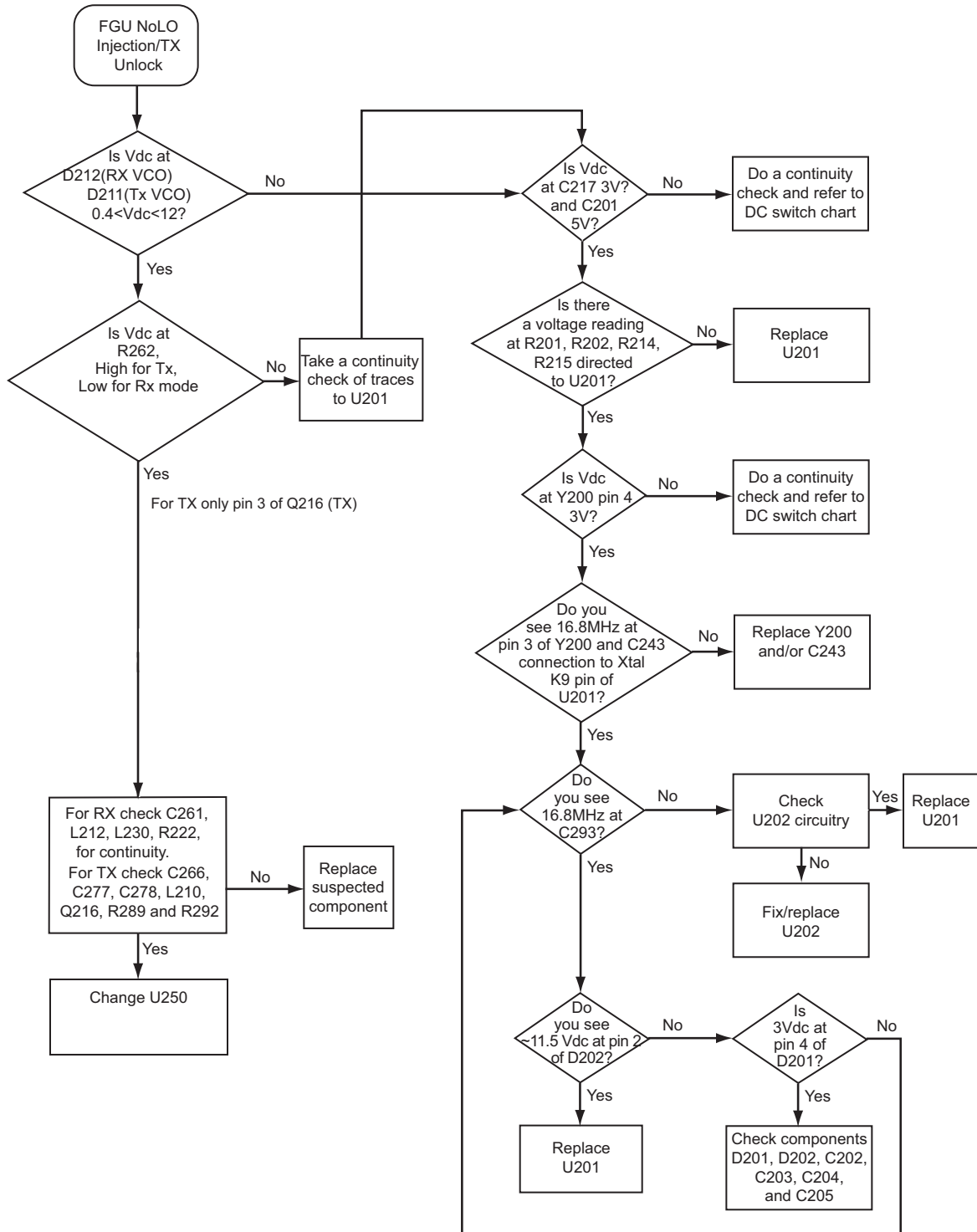

6.5.20 VOCON Transmit Audio Troubleshooting Chart (1 of 2)

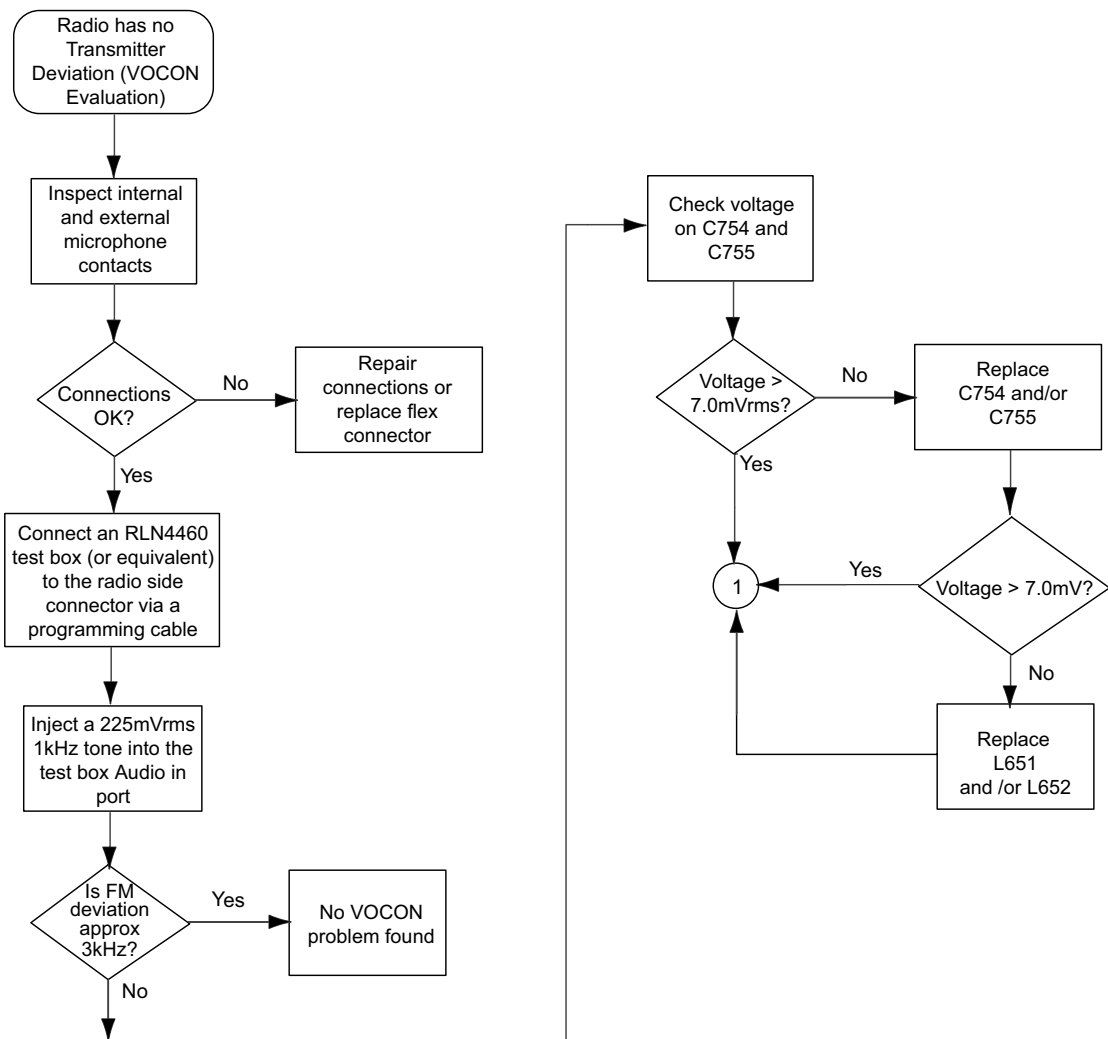

MAEPF-27347-O

6.5.21 VOCON Transmit Audio Troubleshooting Chart (2 of 2)

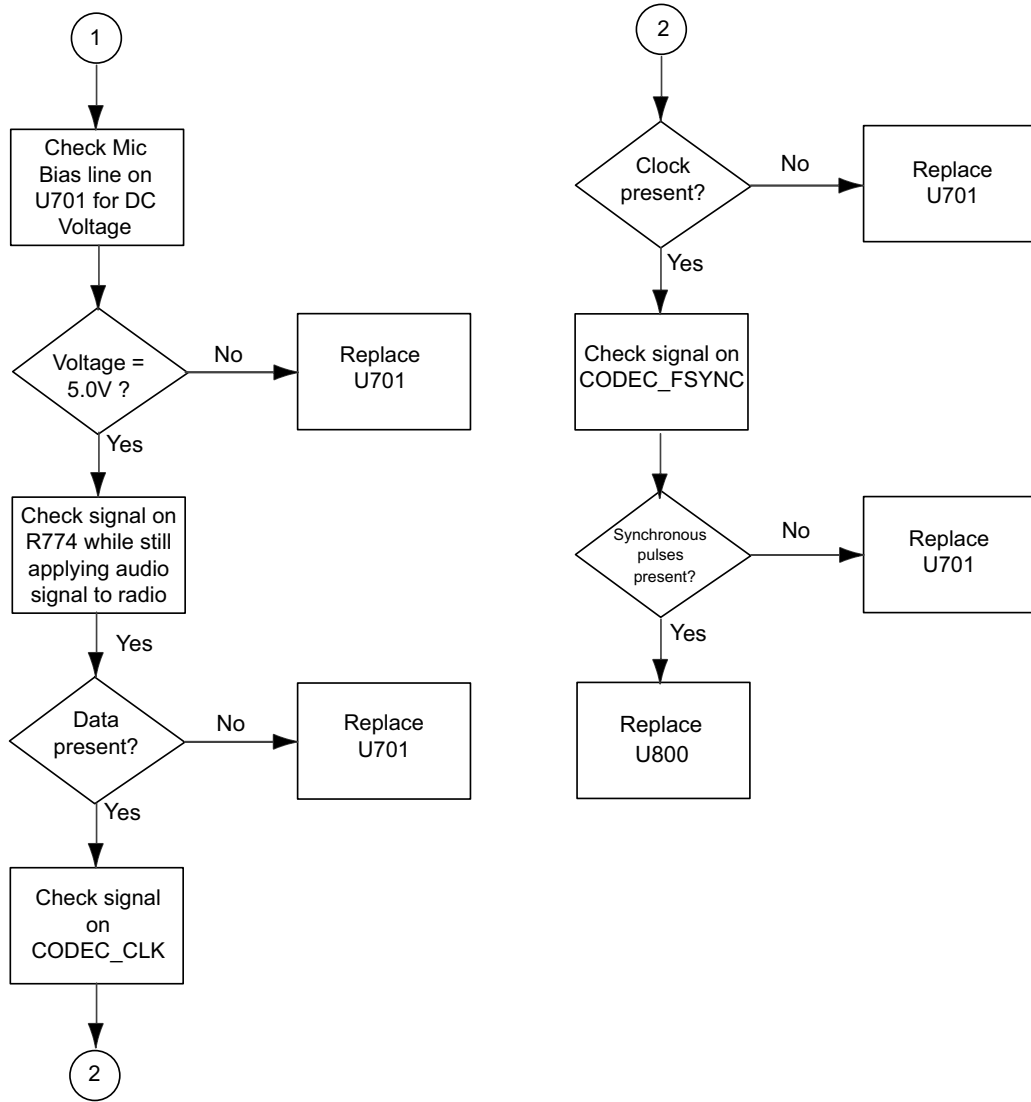

MAEPF-27334-O

6.5.22 No Transmit Deviation Troubleshooting Chart

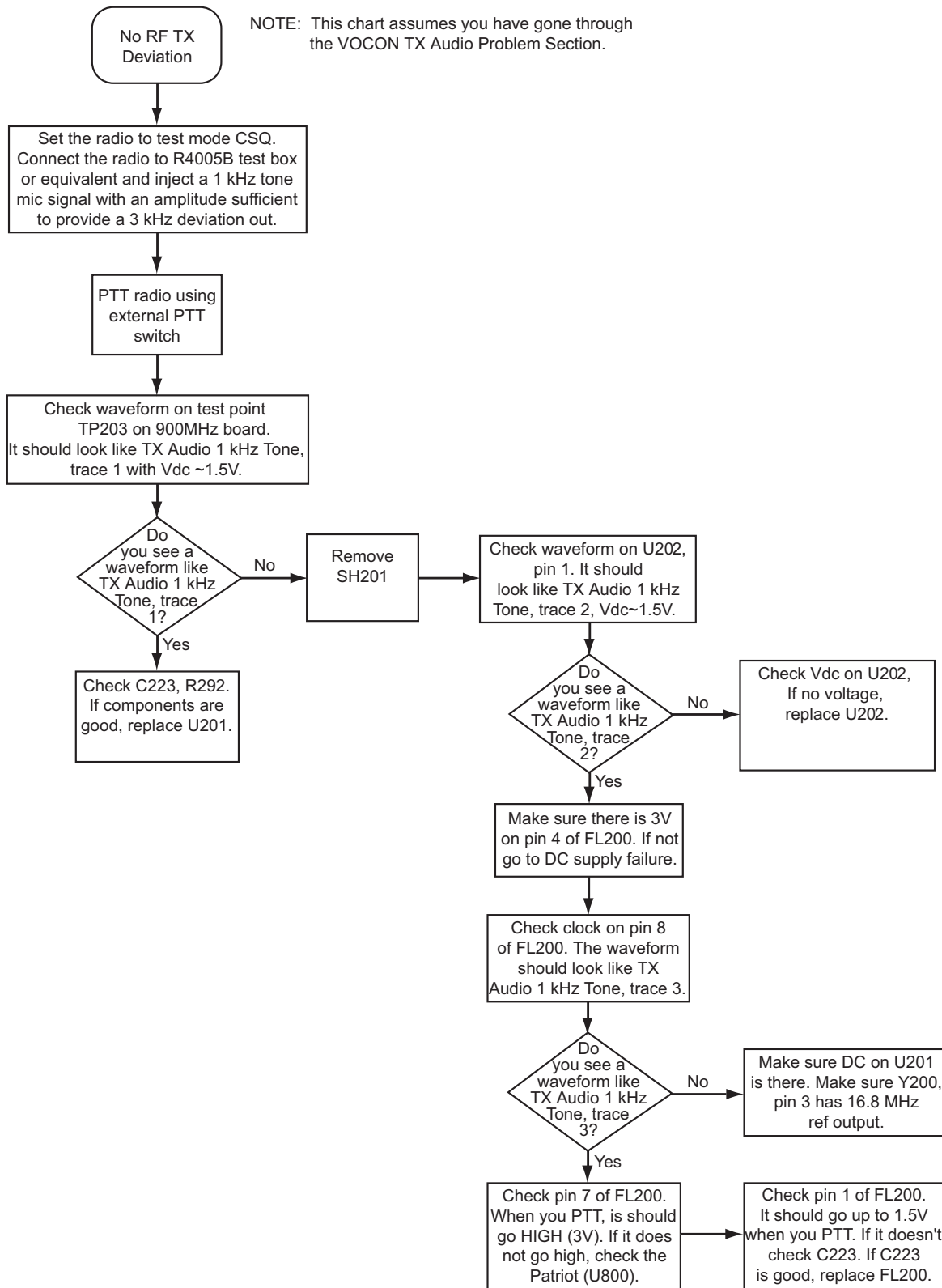

6.5.23900MHz Transmitter RF Troubleshooting Chart

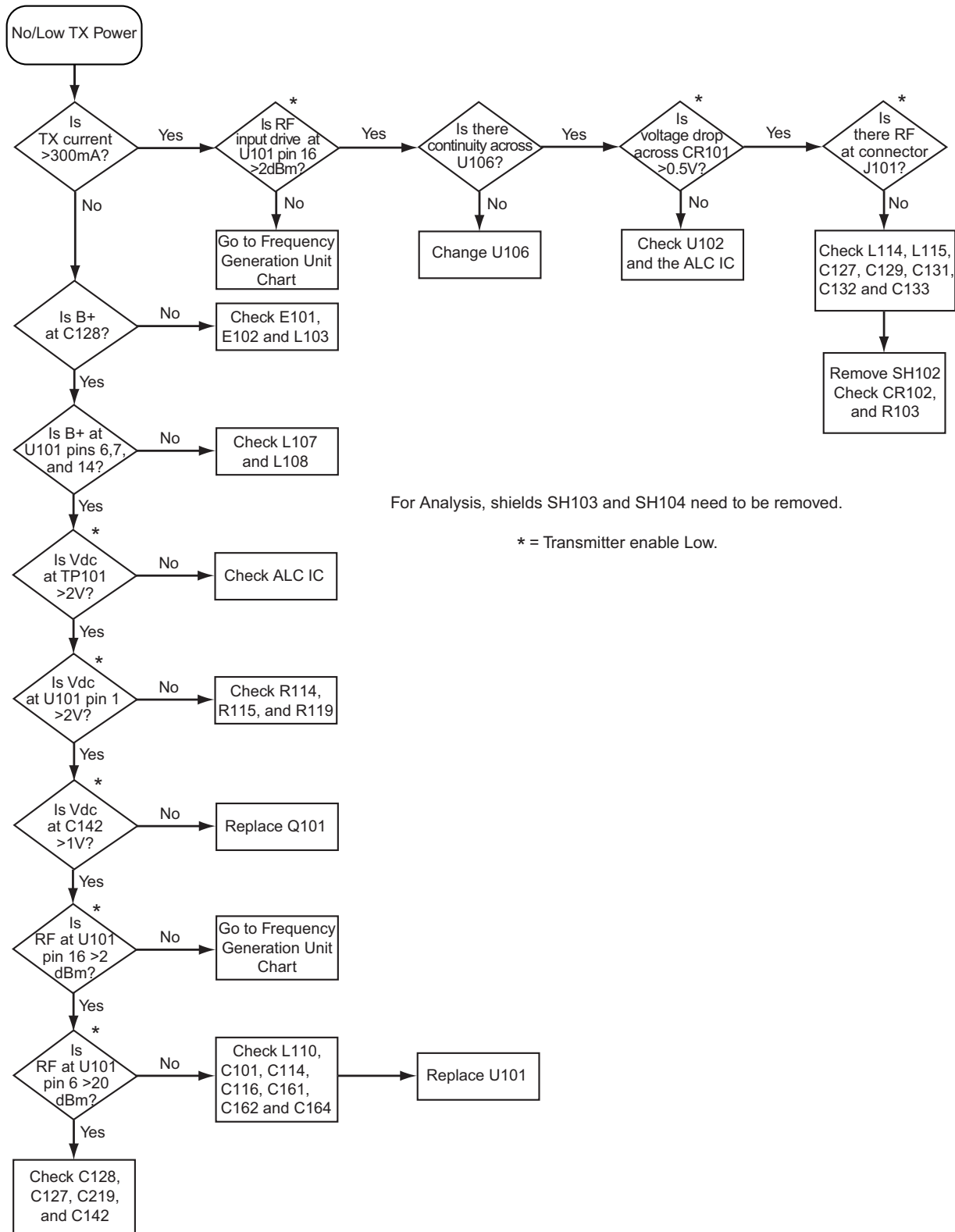

For Analysis, shields SH103 and SH104 need to be removed.

* = Transmitter enable Low.

6.5.24 Secure Hardware Failure

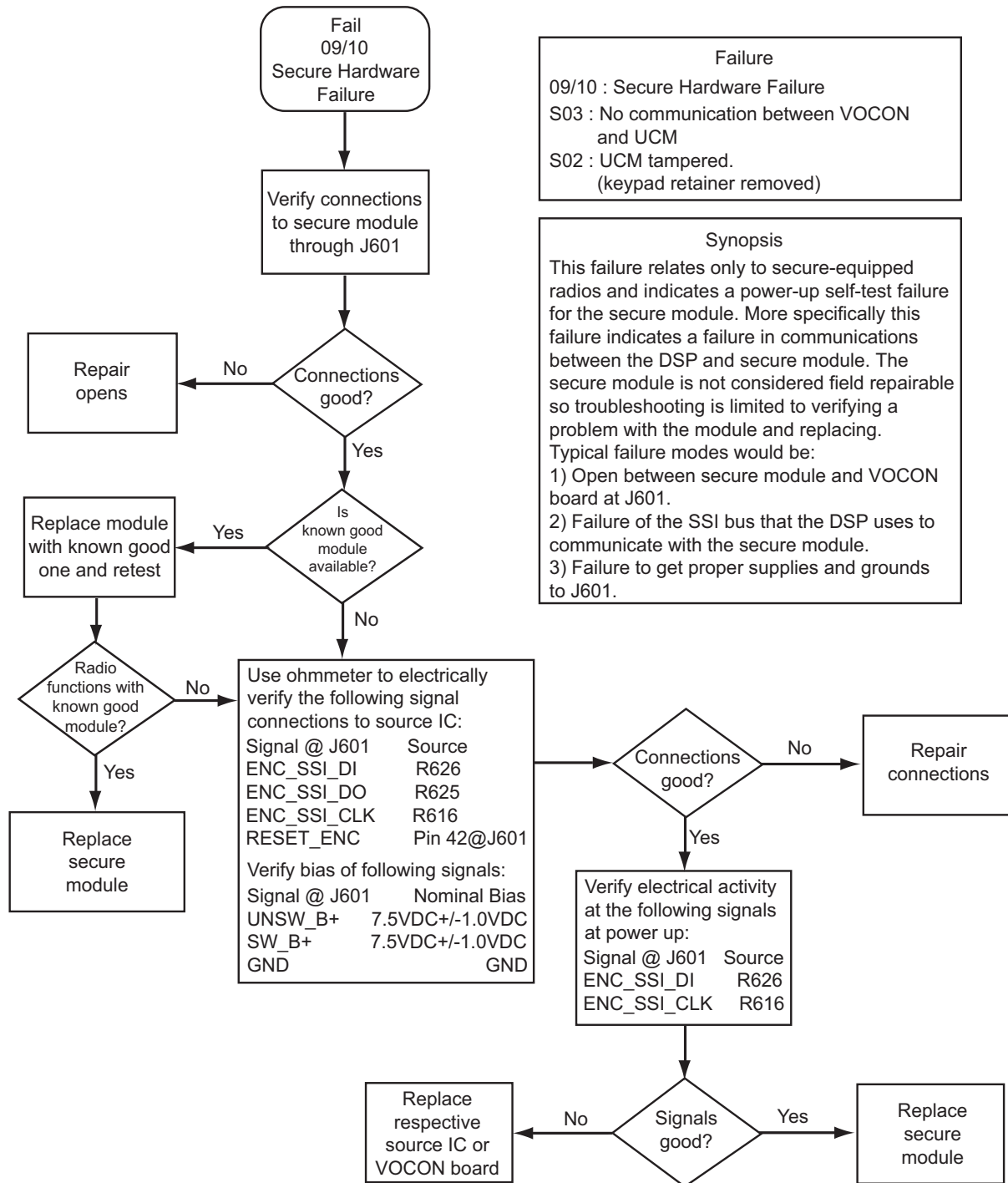

Failure
 09/10 : Secure Hardware Failure
 S03 : No communication between VOCON and UCM
 S02 : UCM tampered. (keypad retainer removed)

Synopsis
 This failure relates only to secure-equipped radios and indicates a power-up self-test failure for the secure module. More specifically this failure indicates a failure in communications between the DSP and secure module. The secure module is not considered field repairable so troubleshooting is limited to verifying a problem with the module and replacing. Typical failure modes would be:
 1) Open between secure module and VOCON board at J601.
 2) Failure of the SSI bus that the DSP uses to communicate with the secure module.
 3) Failure to get proper supplies and grounds to J601.

MAEPF-27387-O

Notes

Chapter 7.1 VHF Troubleshooting Waveforms

7.1.1 Introduction

This chapter contains images of waveforms that might be useful in verifying operation of certain parts of the circuitry. These waveforms are for reference only; the actual data depicted will vary depending upon operating conditions. This manual is to be used in conjunction with the ASTRO XTS 2500/ XTS 2500I Digital Portable Radios Basic Service Manual (Motorola part number 6816984H01), which uses the pass/fail service approach to radio problems.

7.1.2 List of Waveforms

[Table 7.1-1](#) lists each waveform and the page on which the waveform can be found.

Table 7.1-1. List of Waveforms

Waveform	Page No.	Waveform	Page No.
Antenna Input	7.1-6	Low-Noise Amplifier Output	7.1-26
TX Signal at Harmonic Filter Input	7.1-7	Preselector 2 Output	7.1-27
Coupler RF Out	7.1-8	Mixer Out (IF)	7.1-28
TX Signal at PA	7.1-9	Crystal Filter Out	7.1-29
Coupler RF Feedback to PCIC	7.1-10	Abacus Analog 3V	7.1-30
PCIC Control Voltage	7.1-11	2nd LO Control Voltage	7.1-31
TX LO	7.1-12	2nd LO VCO Buffer Output	7.1-32
Higher Level Voltage Multiplier	7.1-13	Abacus Digital 3V	7.1-34
Superfilter Output	7.1-14	TX Audio 1 kHz Tone	7.1-35
Prescaler Input to FracN Synthesizer	7.1-15	16.8 MHz Buffer Input and Output	7.1-36
Reference Crystal Output	7.1-16	32.768 kHz Clock Outputs	7.1-37
Mod In	7.1-17	SPI B Data	7.1-38
1st LO Control Voltage	7.1-18	RX Serial Audio Port (SAP)	7.1-39
VCO Output	7.1-19	SPI Data	7.1-40
Frequency Out (16.8 MHz)	7.1-20	SPI CLK	7.1-41
RX RF Input at Antenna Switch	7.1-21	Universal Chip Select	7.1-42
Antenna Switch Bias	7.1-22	Abacus Chip Select	7.1-43
Preselector Tuning Voltage	7.1-23	RX SSI Data	7.1-44
RX RF Input after Antenna Switch	7.1-24	RX SSI Clock	7.1-45
Analog 5V	7.1-24	RX SSI Frame Sync	7.1-46
Preselector 1 Output	7.1-25		

7.1.3 RF Test Points

The following RF block diagram and accompanying table (Table 7.1-2) shows the location of key probe points (PP) and test points (TP) for the XTS 2500/XTS 2500I radio.

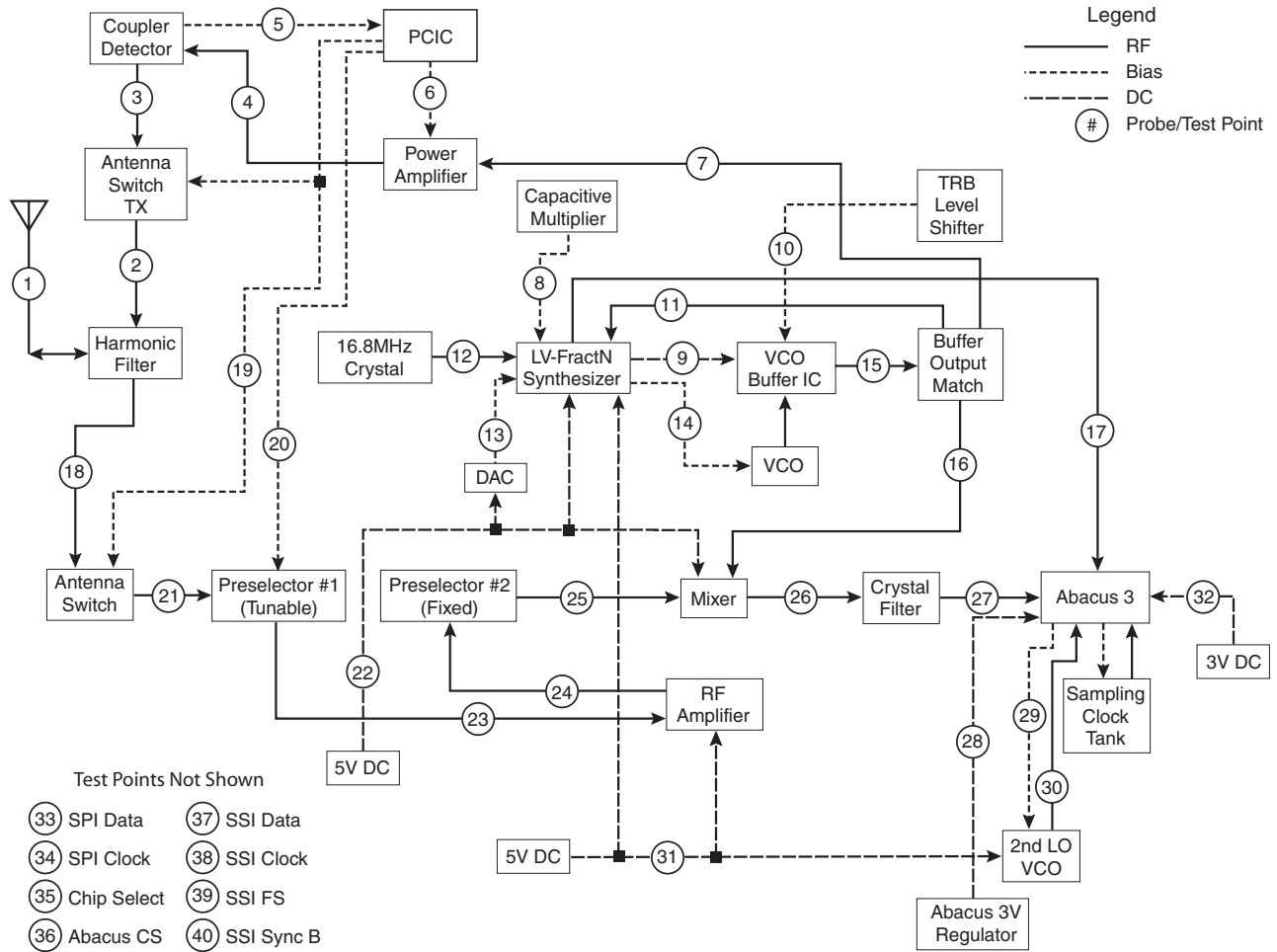

MAEPF-27353-O

Figure 7.1-1. RF Block Diagram Test Points

Table 7.1-2. RF Block Diagram Probe/Test Points

PP/TP	Name	Location	Under RF Shield?	Page
1	Antenna Input	J101, pin 5	No.	7.1-6
2	TX Signal at Harmonic Filter Input	C180	Yes.	7.1-7
3	Coupler RF Out	U103, pin 1	No.	7.1-8
4	TX Signal at PA	Q101, pin 2	No.	7.1-9
5	Coupler RF Feedback to PCIC	TP160	No.	7.1-10
6	PCIC Control Voltage	TP_146	No.	7.1-11
7	TX LO	TP299	No.	7.1-12
8	Higher Level Voltage Multiplier	C210	Yes.	7.1-13
9	Superfilter Output	SF_TP	Yes.	7.1-14
11	Prescaler Input to FracN Synthesizer	TP23	Yes.	7.1-15
12	Reference Crystal Output	R729 and C726	No.	7.1-16
13	Mod In	TP36	No.	7.1-17
14	1st LO Control Voltage	VC_TP	No.	7.1-18
15	VCO Output	C261, C266 and C236	Yes.	7.1-19
17	Frequency Out (16.8 MHz)	16out	No.	7.1-20
18	RX RF Input at Antenna Switch	C1	No.	7.1-21
20	Preselector Tuning Voltage	C15 and C46	No.	7.1-23
22	Analog 5V	U500, pin 5	No.	7.1-24
23	Preselector 1 Output	C16	Yes.	7.1-25
24	Low-Noise Amplifier Output	C35	Yes	7.1-26
25	Preselector 2 Output	C47	Yes	7.1-27
26	Mixer Out (IF)	C68	Yes.	7.1-28
27	Crystal Filter Out	L56	Yes	7.1-29
28	Abacus Analog 3V	U501, pin 5	No.	7.1-30
29	2nd LO Control Voltage	U401, pin 38	Yes.	7.1-31
30	2nd LO VCO Buffer Output	C433	Yes.	7.1-32
31	Analog 5V	U500, pin 5	No.	7.1-33
32	Abacus Digital 3V	U502, pin 5	No.	7.1-34
33	SPI Data	R802	No.	7.1-40
34	SPI CLK	R803	No.	7.1-41
35	Universal Chip Select	U102, pin 29	No	7.1-42
36	Abacus Chip Select	U401, pin 25	Yes.	7.1-43
37	RX SSI Data	SSI_D	No.	7.1-44

Table 7.1-2. RF Block Diagram Probe/Test Points (Continued)

PP/TP	Name	Location	Under RF Shield?	Page
38	RX SSI Clock	SSI_CLK	No.	7.1-45
39	RX SSI Frame Sync	SSI_FS	No.	7.1-46

PP = Probe Point
 TP = Test Point

Note: For test/probe points indicated with the SH prefix, use an HP 85024A High Frequency Probe to detect a signal. The probe should be placed in center of the hole located on the top of the shield. Make sure the probe does not touch the shield or any other components.

7.1.4 Main Circuit Board RF Shield Locations

Viewed from Side 1

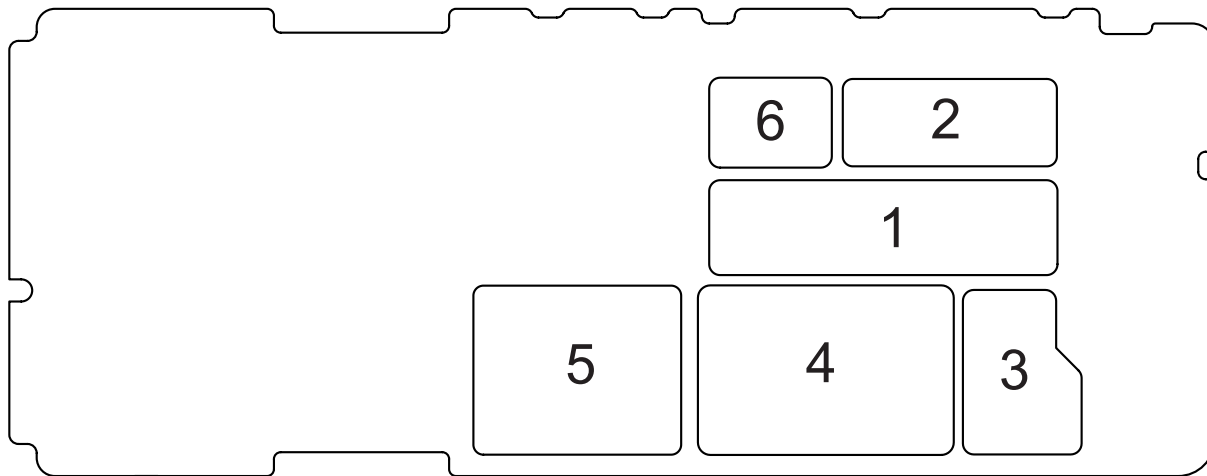

Table 7.1-3. Main Circuit Board Side 1 RF Shields

Item Number	Reference Number	Motorola Part Number	Description
1	SH51	2686700Z02	Shield, Mixer
2	SH402	2686698Z02	Shield, 2nd LO
3	SH102	2686701Z02	Shield, Harmonic Filter
4	SH101	2686702Z02	Shield, PCIC
5	SH251	2616559H01	Shield, VCO Top
6	SH52	2686699Z02	Shield, Crystal IF

Viewed from Side 2

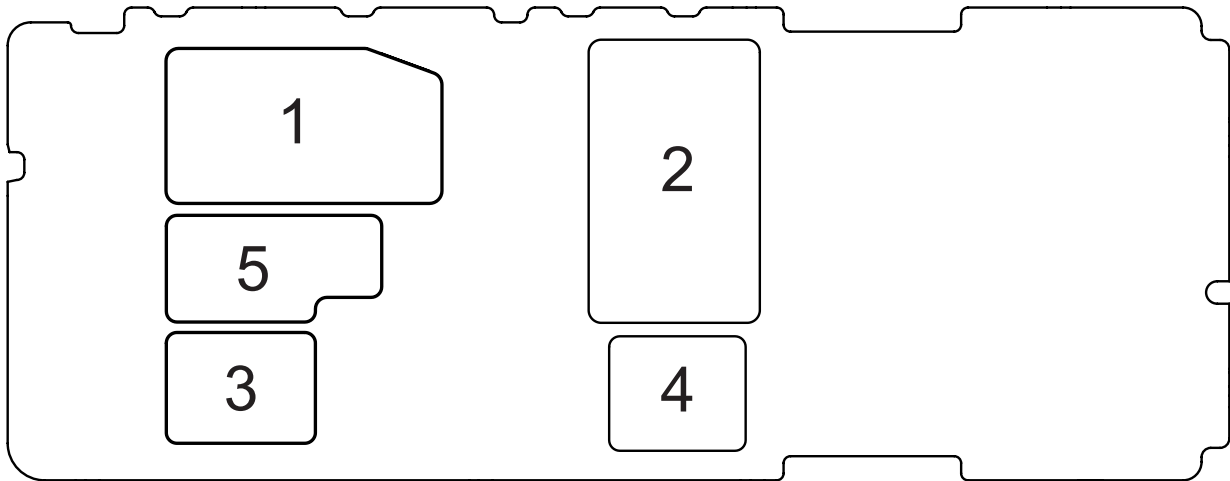
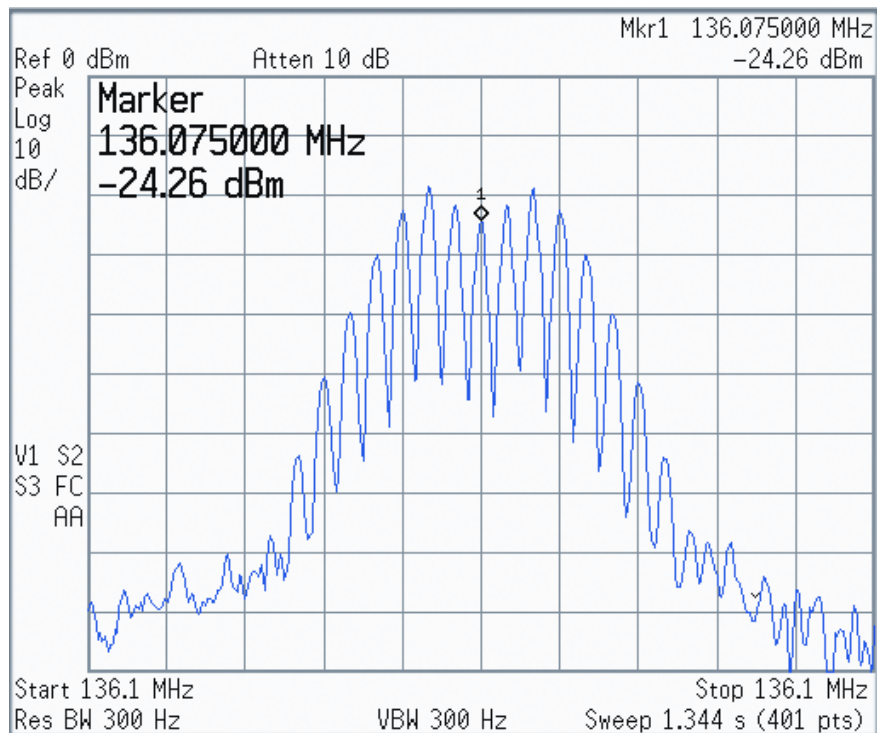
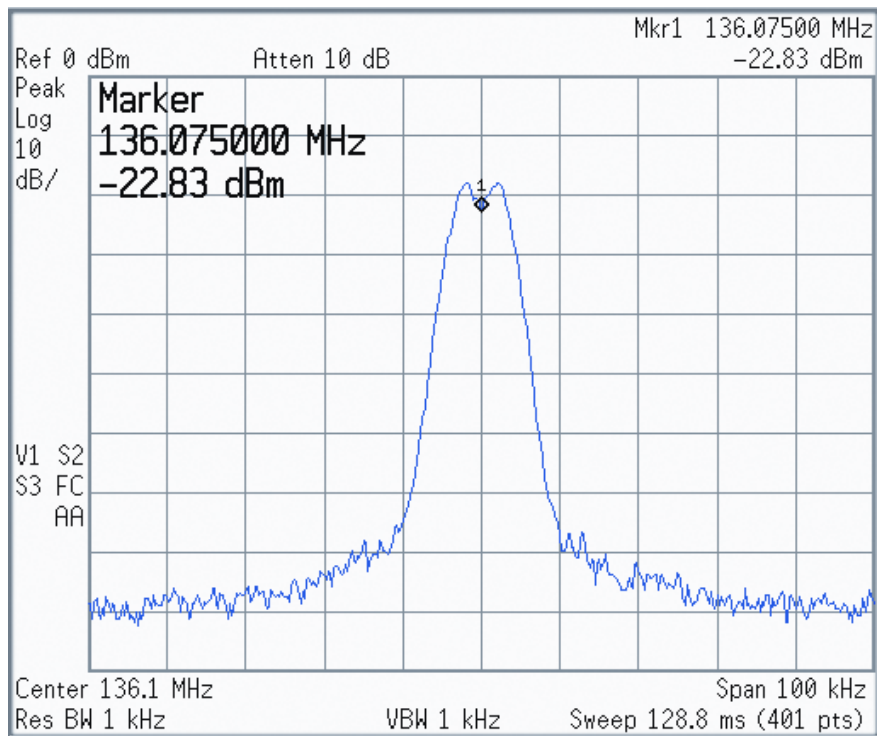

Table 7.1-4. Main Circuit Board Side 2 RF Shields

Item Number	Reference Number	Motorola Part Number	Description
1	SH401	2686706Z02	Shield, ABACUS
2	SH201	2686705Z02	Shield, Synthesizer
3	SH103	2686708Z02	Shield, Coupler Bottom
4	SH252	2616559H01	Shield, VCO Bottom
5	SH1	2686707Z02	Shield, Front End Filter

7.1.5 PP1 Antenna Input



Probe point: J101, pin 5.

Typical RX signal with 1 kHz modulation. Display shows modulation components of carrier.

7.1.6 PP2 TX Signal at Harmonic Filter Input

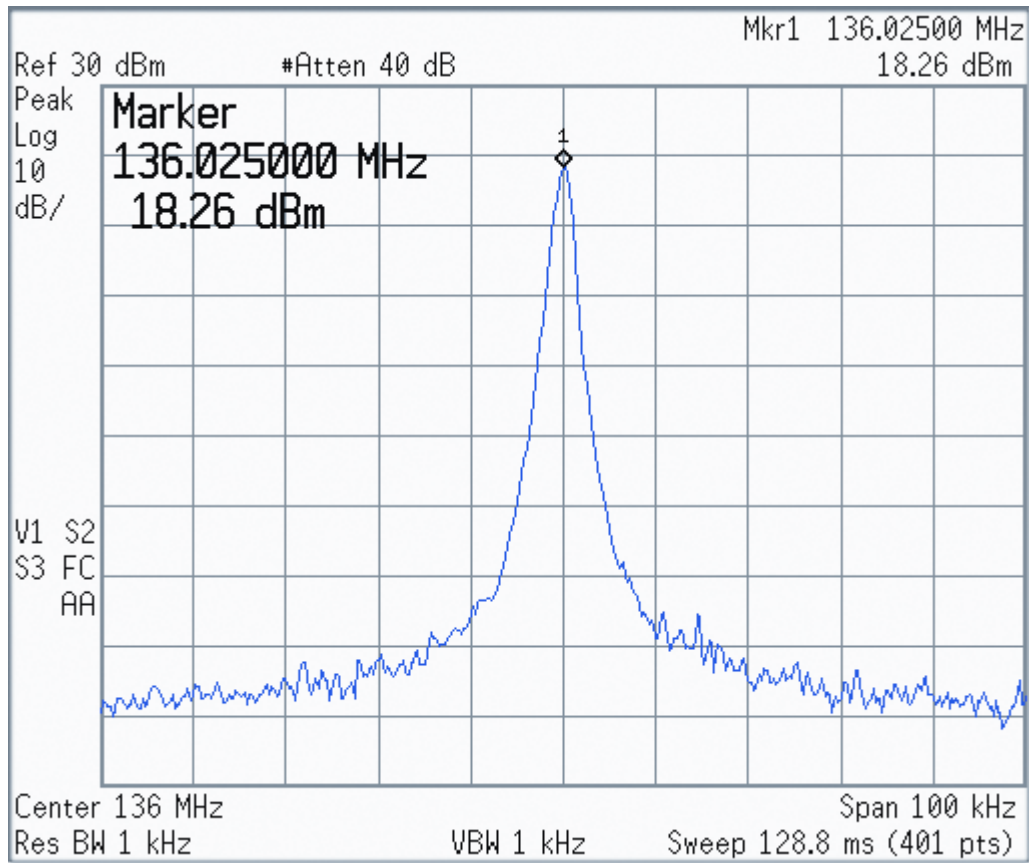

Probe point: C180 (located under shield).

7.1.7 PP3 Coupler RF Out

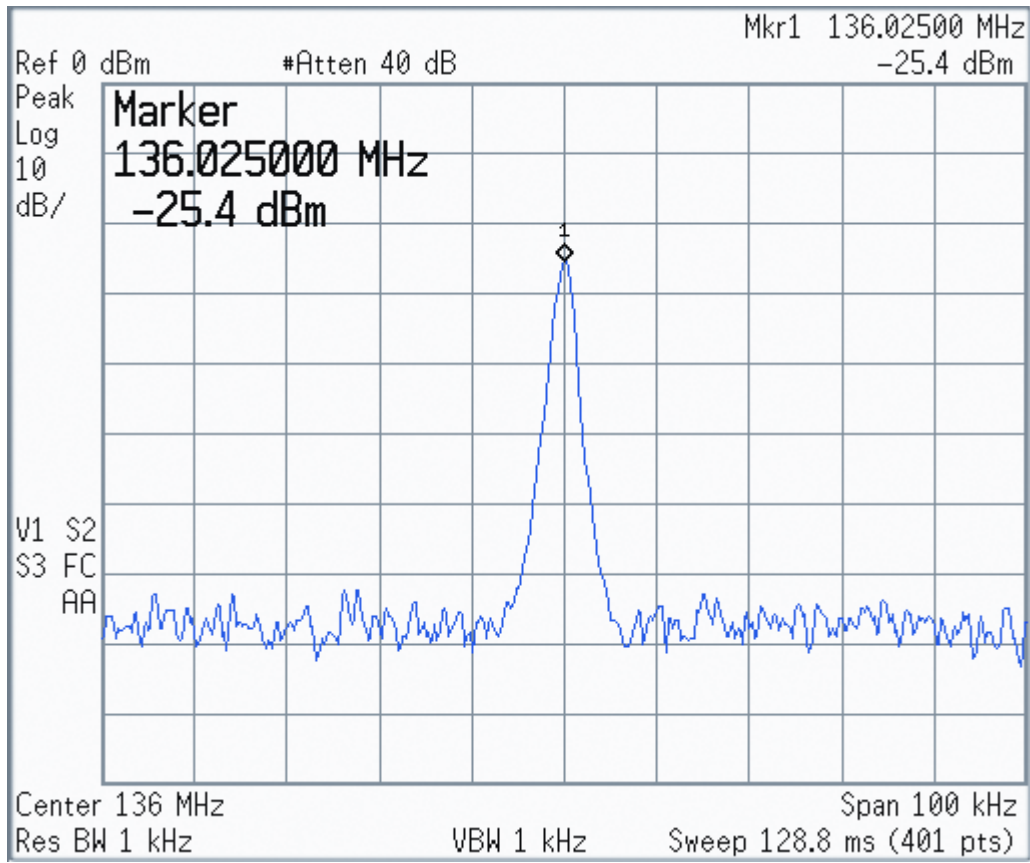

Probe point: U103, pin 1.

7.1.8 PP4 TX Signal at PA

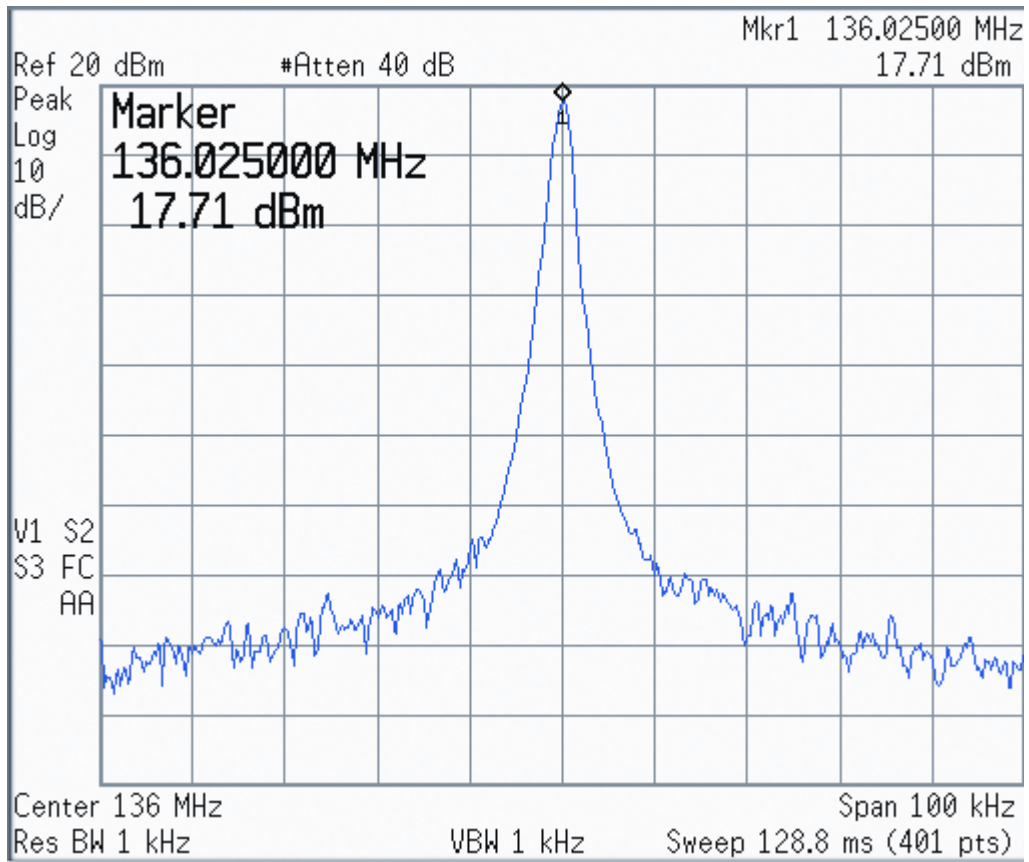

Probe point: Q101, pin 2.

7.1.9 TP5 Coupler RF Feedback to PCIC

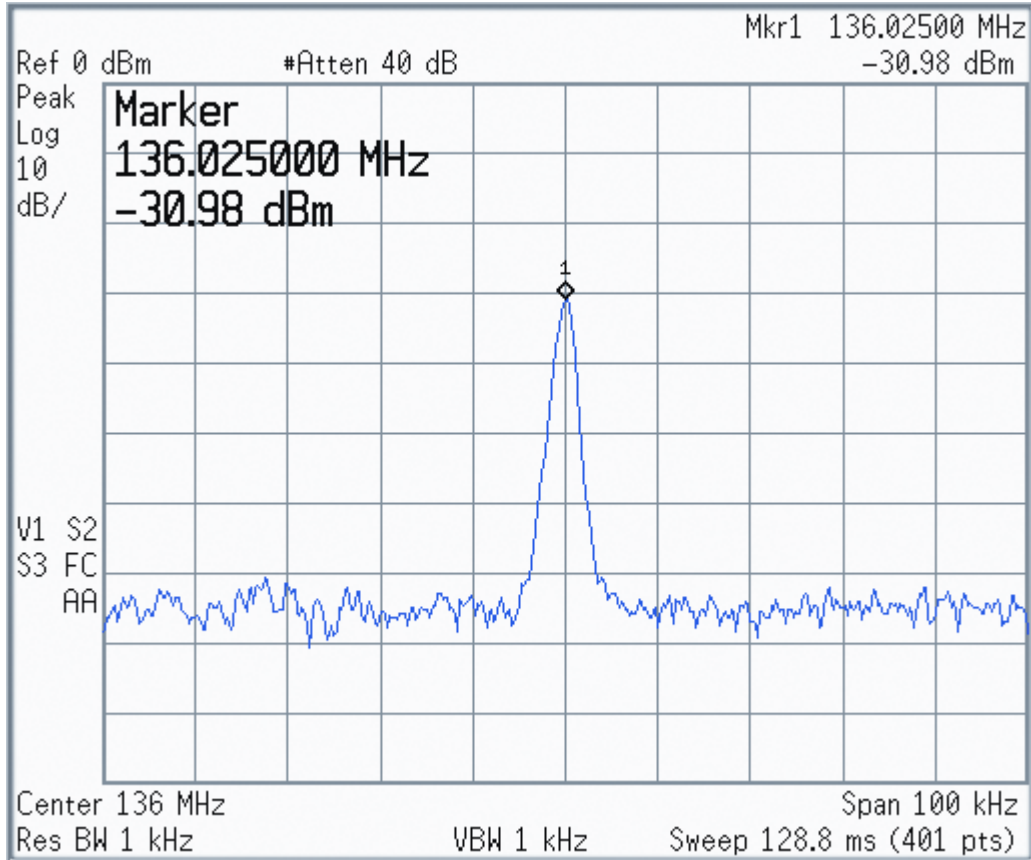

Test point: TP_160.

7.1.10 TP6 PCIC Control Voltage

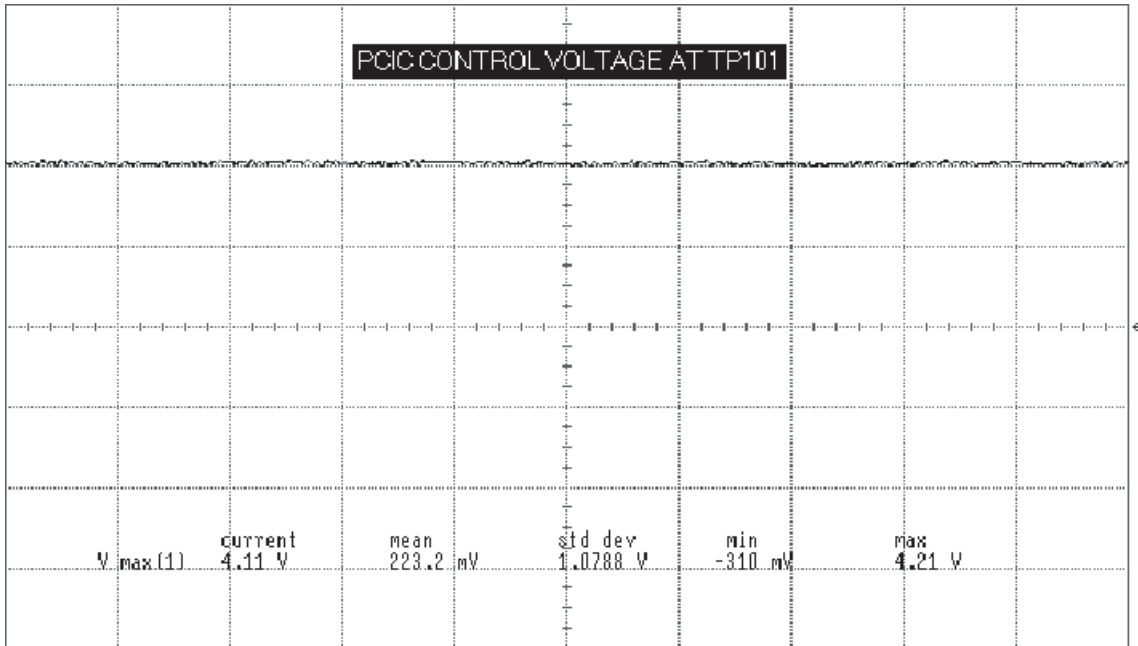

Test point: TP146.

7.1.11 PP7 TX LO

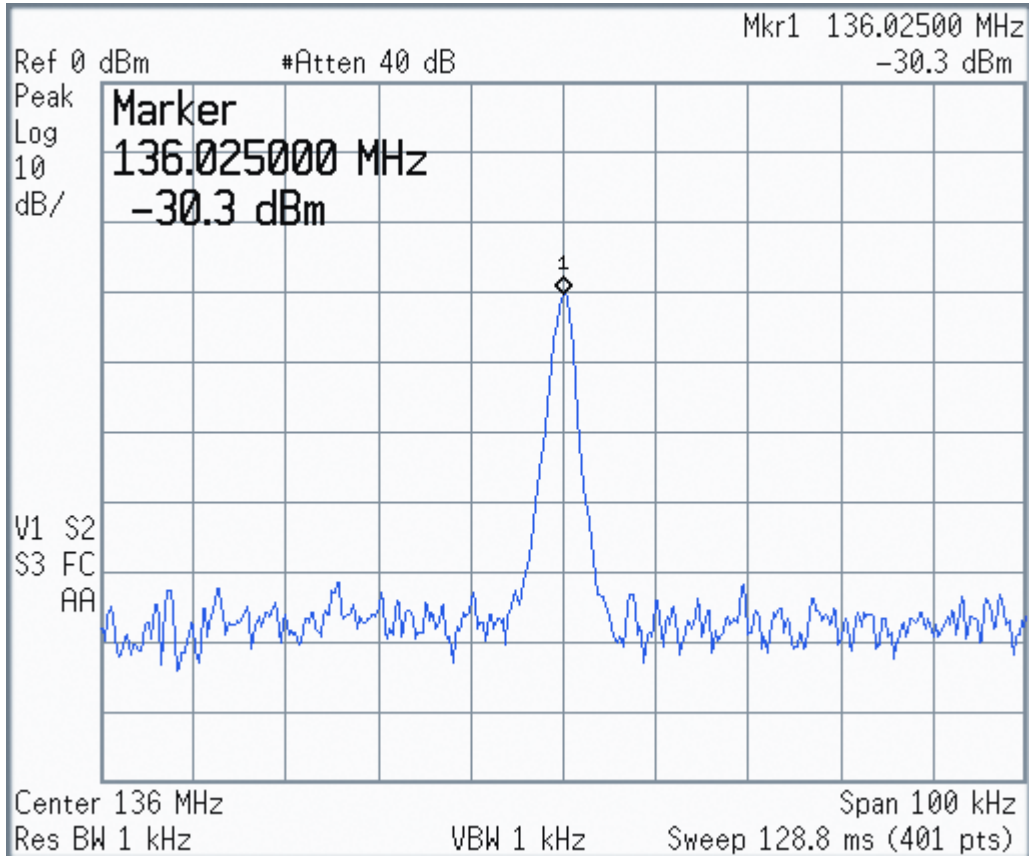

Probe point: TP299.

7.1.12 PP8 Higher Level Voltage Multiplier

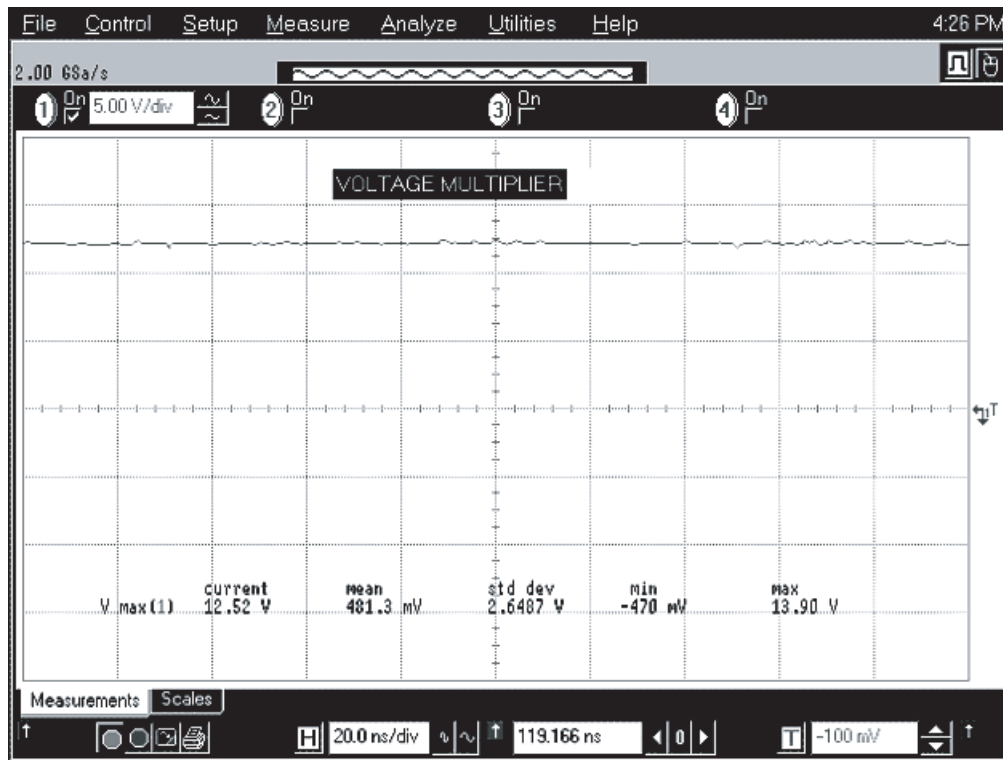

Probe point: C210 (located under shield).

7.1.13 PP9 Superfilter Output

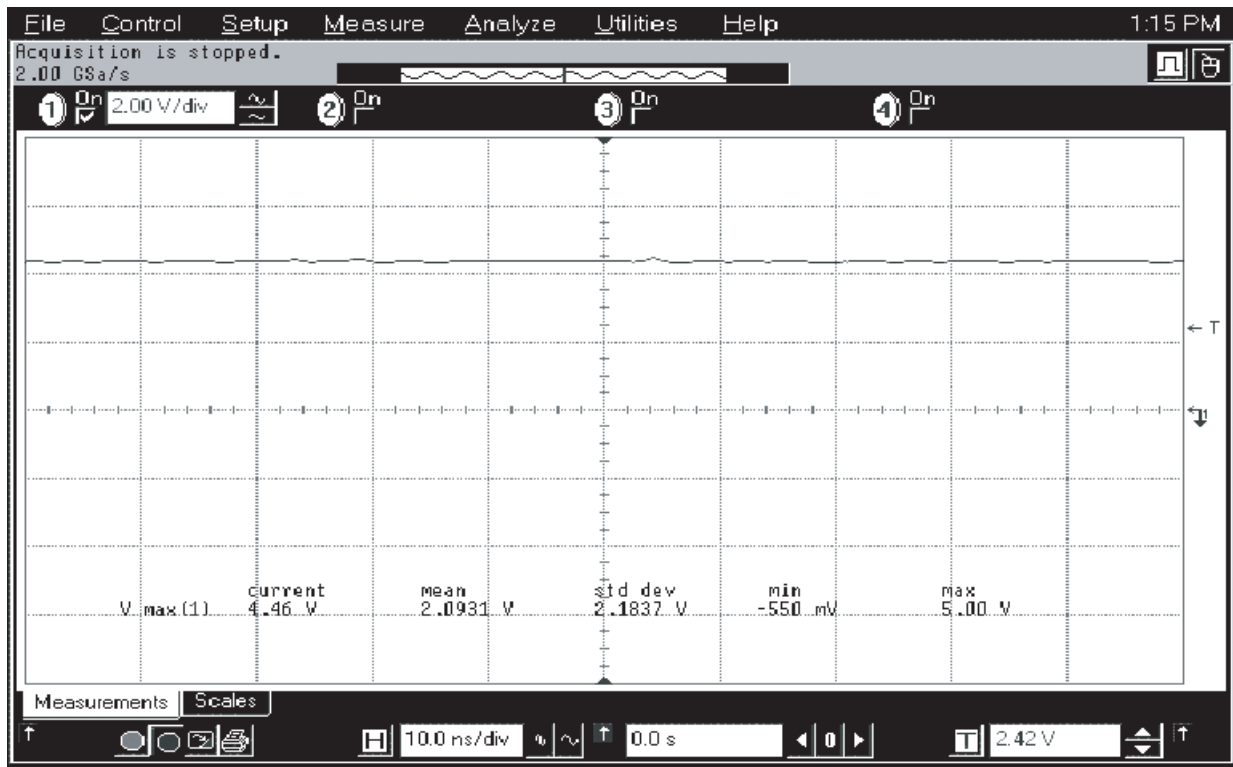

Probe point: SF_TP (located under shield).

7.1.14 PP11 Prescalar Input to FracN Synthesizer

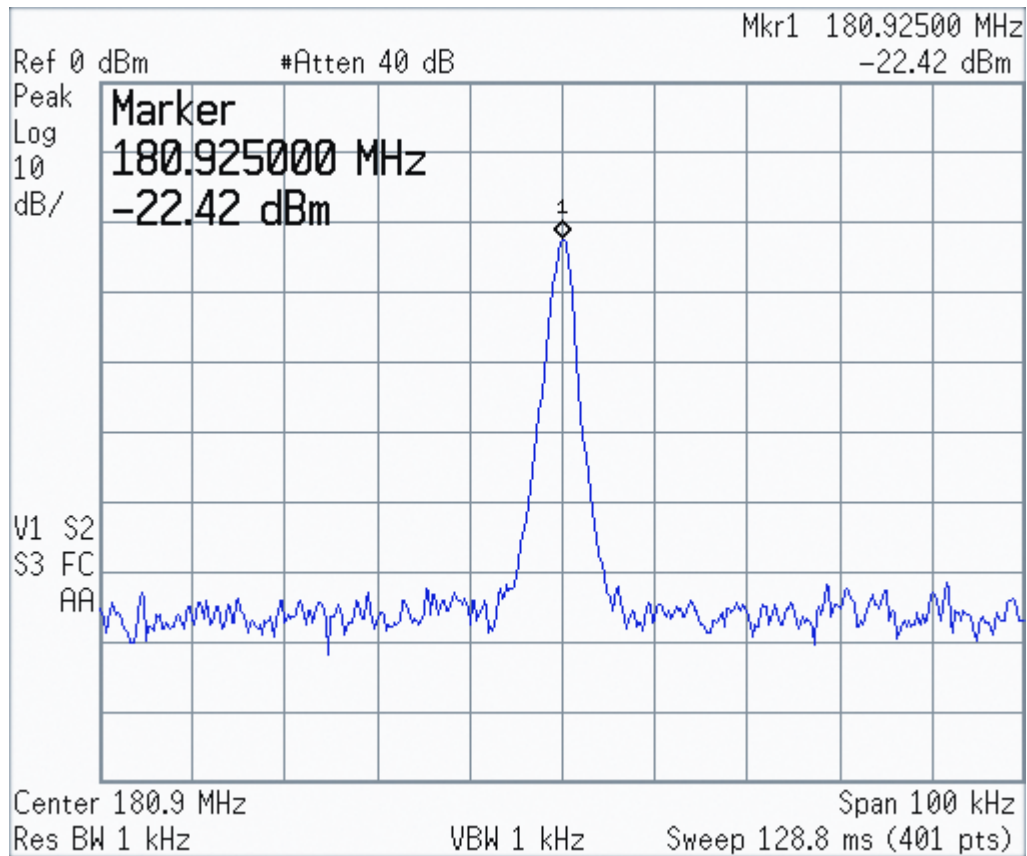

Probe point: TP23 (located under shield).

7.1.15 PP12 Reference Crystal Output

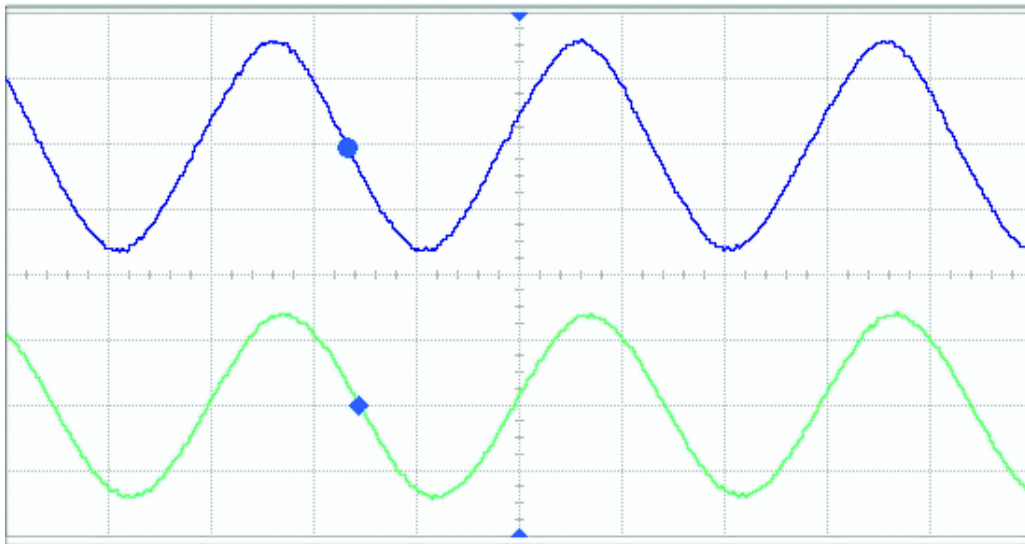

Acquisition Sampling mode real time Normal
 Memory depth automatic 64000 pts
 Sampling rate automatic Sampling rate 4.00 GSa/s
 Averaging off Interpolation on

Channel 1 Scale 300 mV/ Offset 1.546 V
 Coupling DC Impedance 1M Ohm

Channel 4 Scale 400 mV/ Offset 2.154 V
 Coupling DC Impedance 1M Ohm

Time base Scale 20.0 ns/ Position 0.0 s Reference center

Trigger Mode edge Sweep auto
 Sensitivity normal Holdoff time 50 ns Coupling DC
 Source channel 4 Trigger level 1.354 V Slope rising

Measure	V p-p(1)	Frequency(1●)	V p-p(4)	Frequency(4★)
Current	983 mV	16.82001 MHz	1.137 V	16.83329 MHz
Mean ?	977.0 mV	? 16.815154 MHz	1.1378 V	16.802593 MHz
Min ?	57 mV	? 16.63969 MHz	1.008 V	16.65859 MHz
Max ?	993 mV	? 25.09409 MHz	1.237 V	16.94801 MHz
Range ?	936 mV	? 8.454399 MHz	229 mV	289.41886 kHz
Std Dev ?	39.6 mV	? 357.28113 kHz	14.5 mV	53.754484 kHz
# of Meas	551	551	553	553
Edge Dir		Falling		Falling

**Probe point: R729 (16_8_filtered)
 C726 (16_8MHZ).**

7.1.16 TP13 Mod In

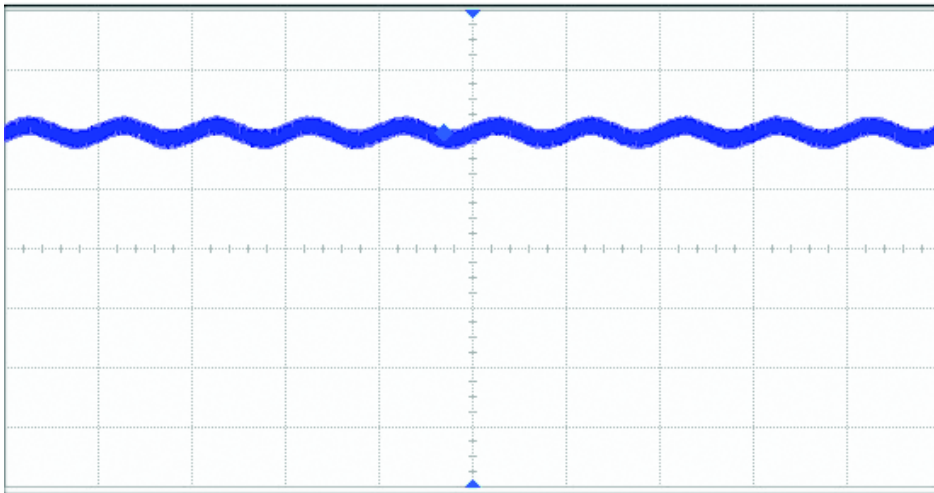

Acquisition Sampling mode real time Normal
 Memory depth automatic 2003639 pts
 Sampling rate automatic Sampling rate 200 MSa/s
 Averaging off Interpolation on

Channel 1 Scale 4.00 V/ Offset -6.35 V
 Coupling DC Impedance 1M Ohm

Time base Scale 1.00 ms/ Position 0.0 s Reference center

Trigger Mode edge Sweep auto
 Sensitivity normal Holdoff time 50 ns Coupling DC
 Source channel 1 Trigger level 1.50 V Slope rising

Measure	V max(1)	V p-p(1)	Frequency(1*)
Current	2.53 V	2.17 V	1.0638298 kHz
Mean	2.53 V	2.17 V	1.0638298 kHz
Min	2.53 V	2.17 V	1.0638298 kHz
Max	2.53 V	2.17 V	1.0638298 kHz
Range	0.0 V	0.0 V	0.0 Hz
Std Dev	0.0 V	0.0 V	0.0 Hz
# of Meas	1	1	1
Edge Dir			Falling

Test point: TP36.

7.1.17TP14 1st LO Control Voltage

Typical value when tuned to receive at 136.075MHz

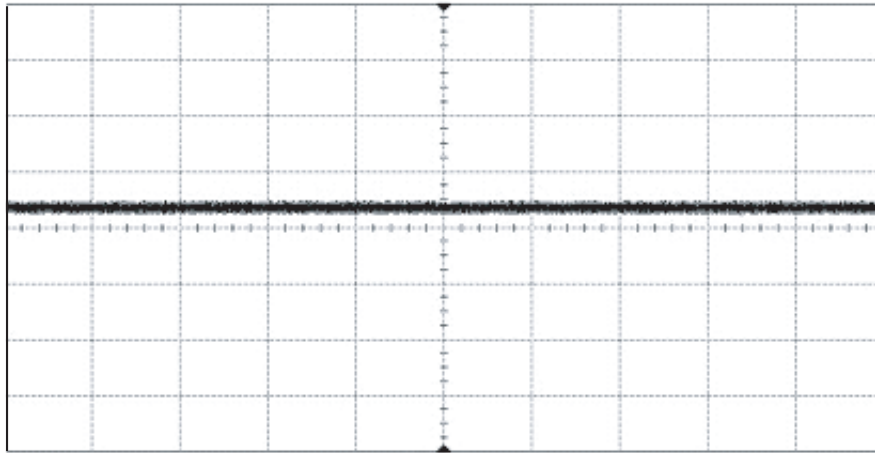

Measure	V max(1)	V p-p(1)
Current	2.45 V	1.28 V
Mean	2.45 V	1.28 V

Typical value when tuned to receive at 173.925MHz

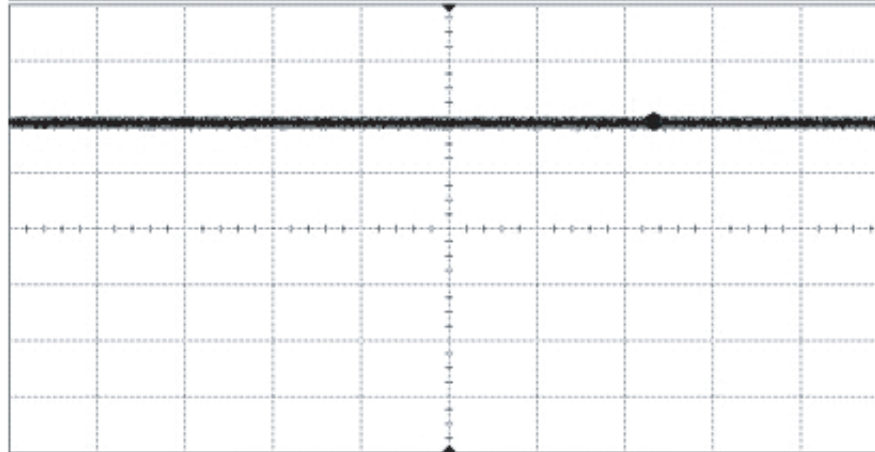

Measure	V max(1)	V p-p(1)
Current	10.07 V	1.30 V
Mean	10.07 V	1.30 V

Test point VC_TP

7.1.18 PP15 VCO Output

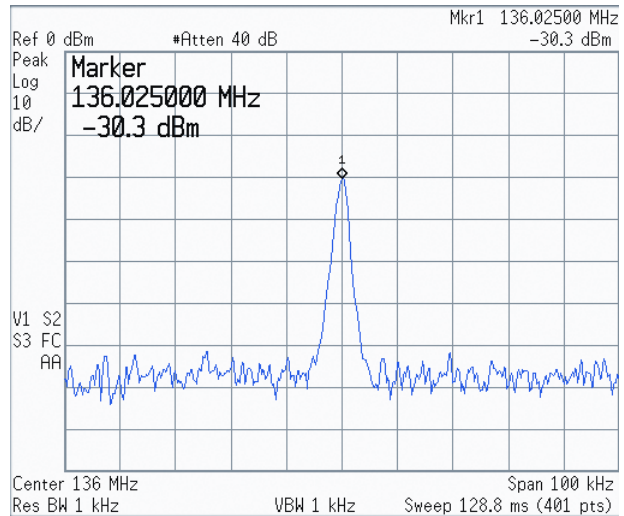
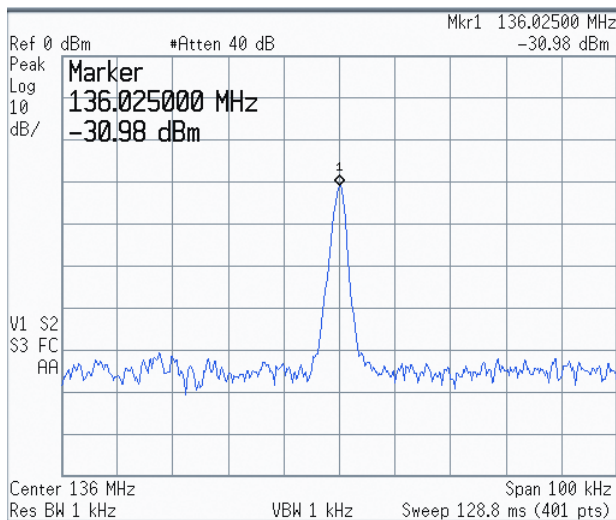
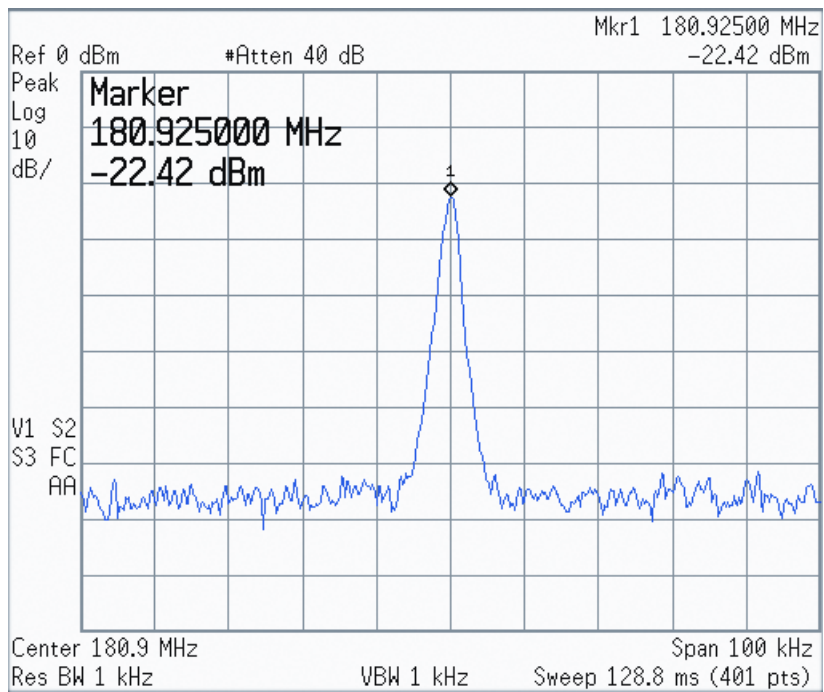

**Probe point: TP298 for LO Output
 TP299 for TX Output
 TP23 for Preselector Output (located under shield).**

Probe point: C261 (located under shield).

7.1.19 PP17 Frequency Out (16.8 MHz)

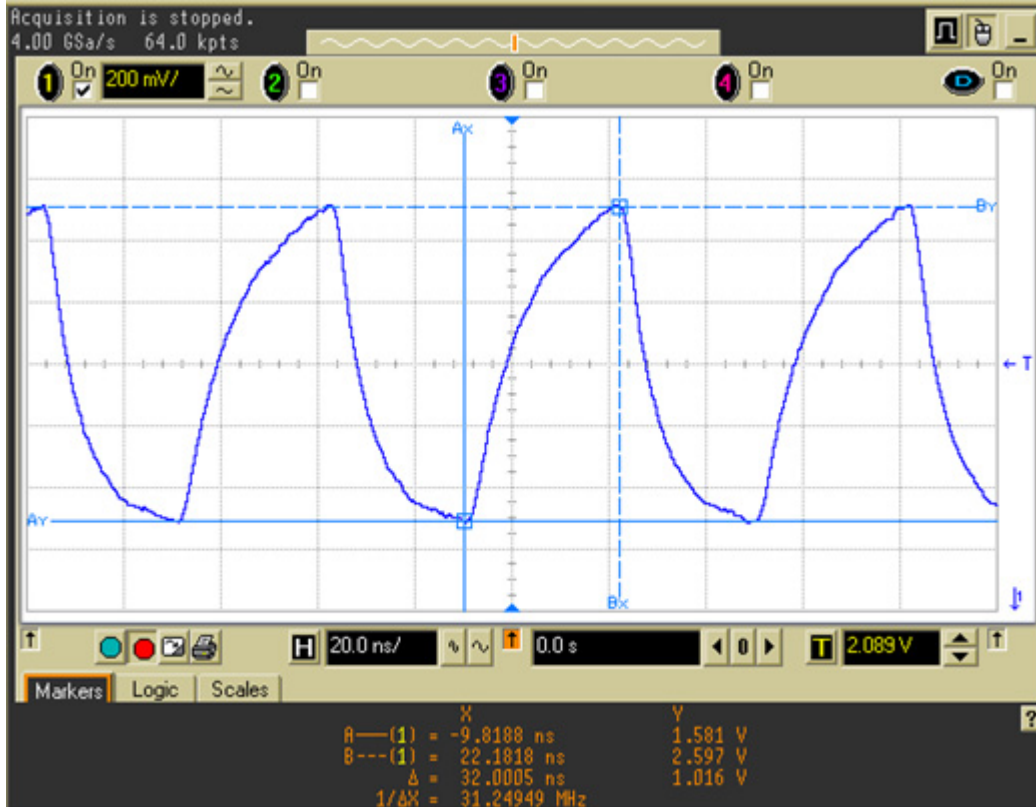

Probe point: 16out (Test Point).

7.1.20 PP18 RX RF Input at Antenna Switch

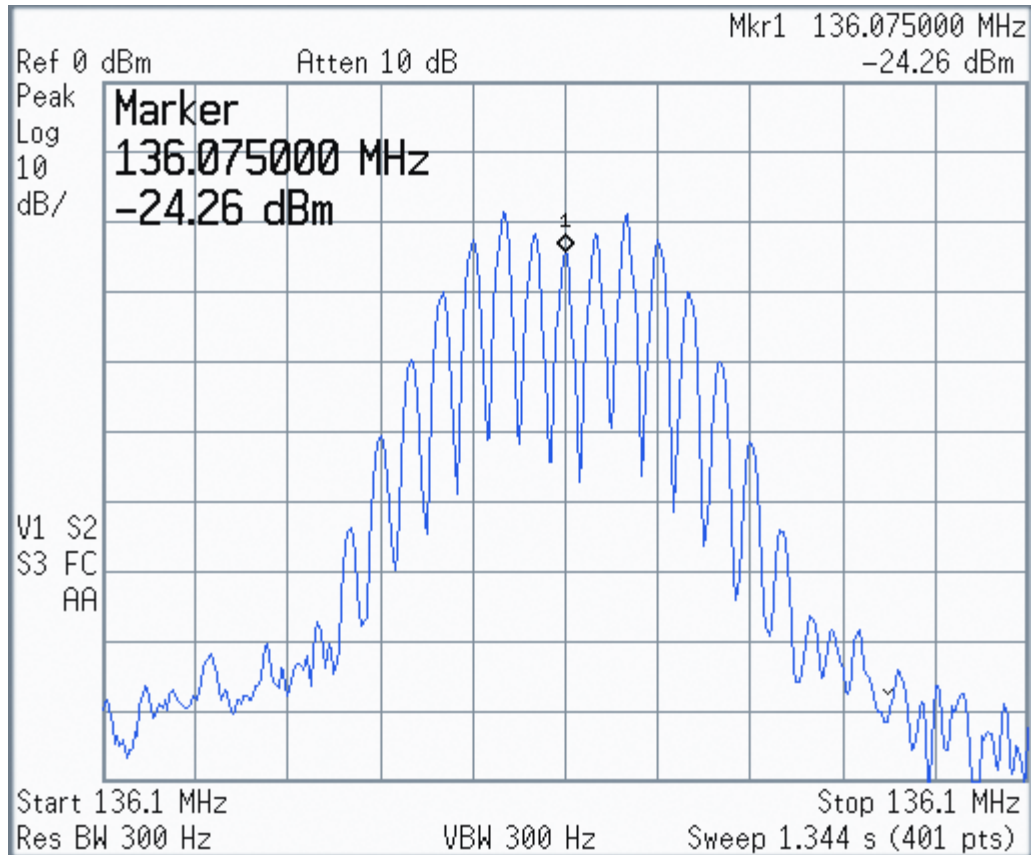

Probe point: C1.

Typical RX signal with 1 kHz modulation. Display shows modulation components of carrier.

7.1.21 PP19 Antenna Switch Bias

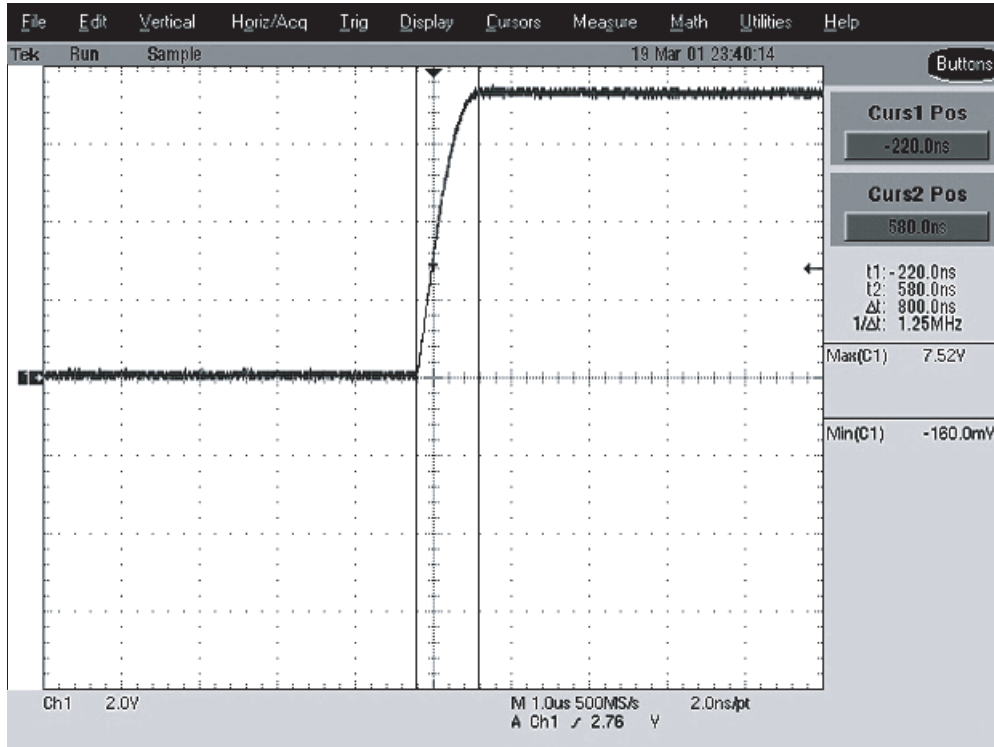

Probe point: U103, pin 1.

Display shows transition between RX mode (low) and TX mode (high).

7.1.22 PP20 Preselector Tuning Voltage

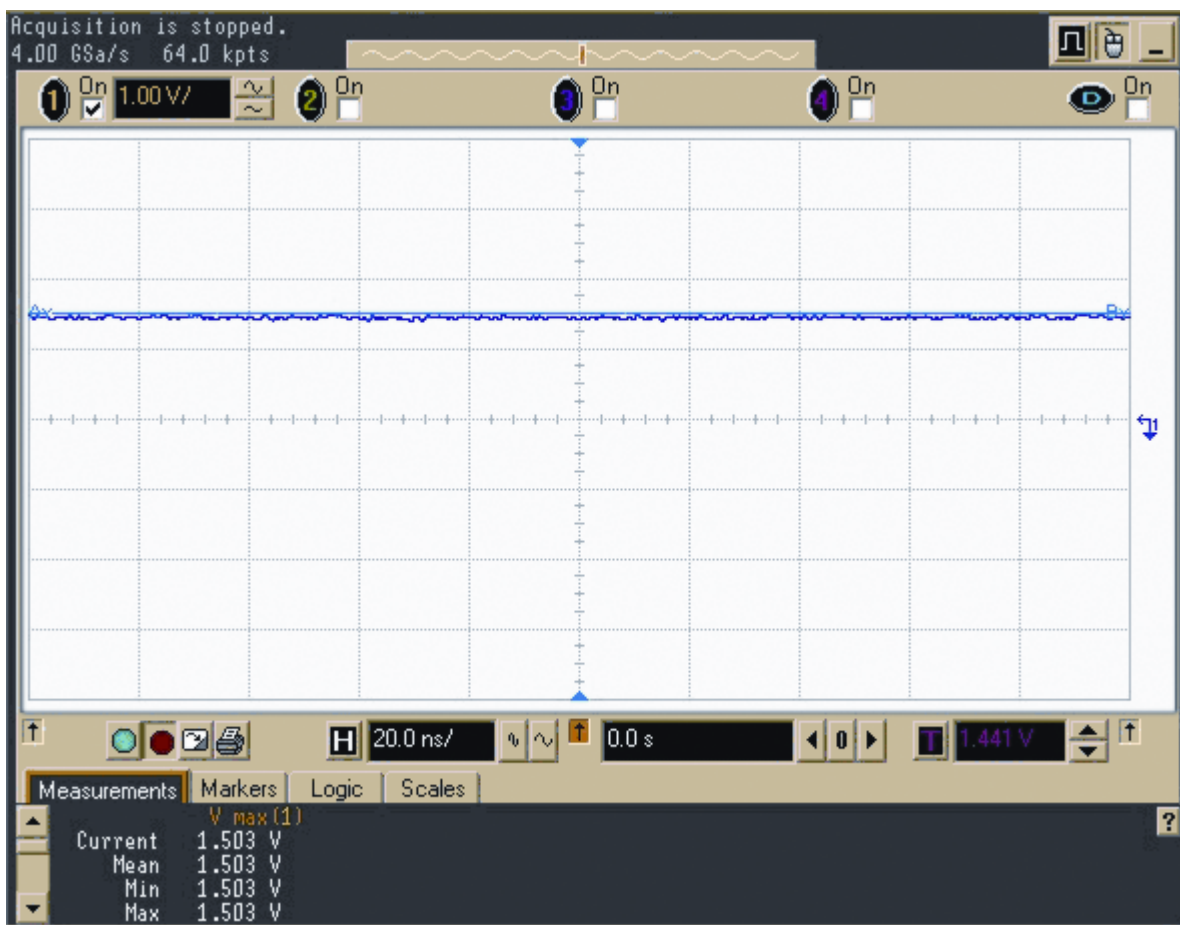

Probe point: C15 and C46.

This is a typical value when tuned to receive at 136.075MHz.

7.1.23 PP22 Analog 5V

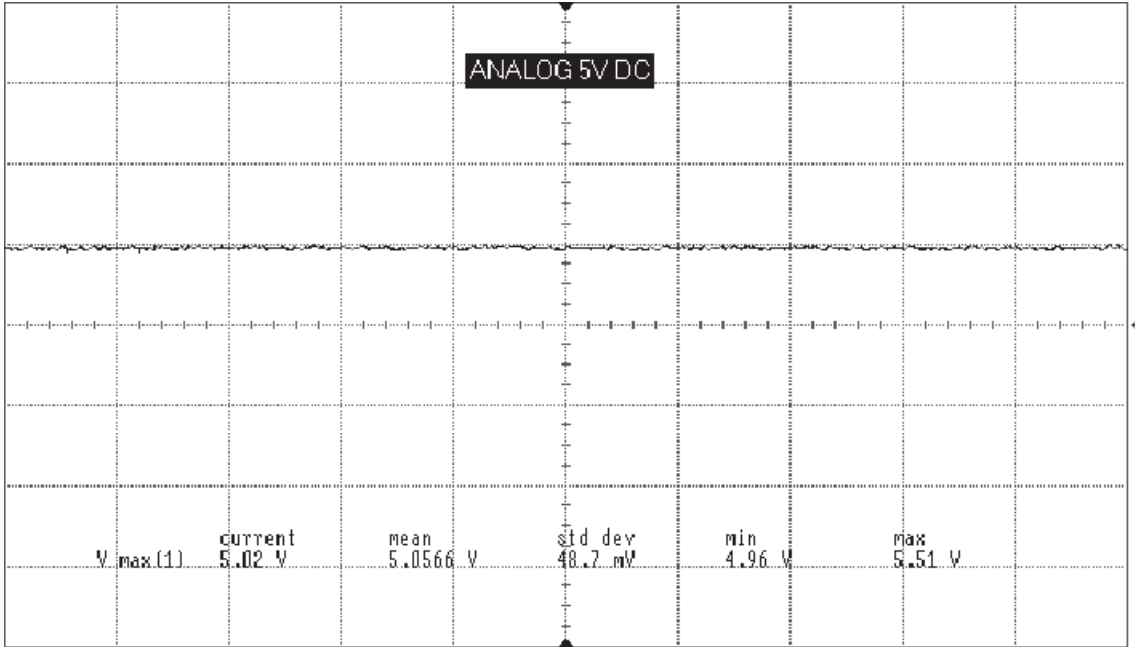

Probe point: U500, pin 5.

7.1.24 PP23 Preselector 1 Output

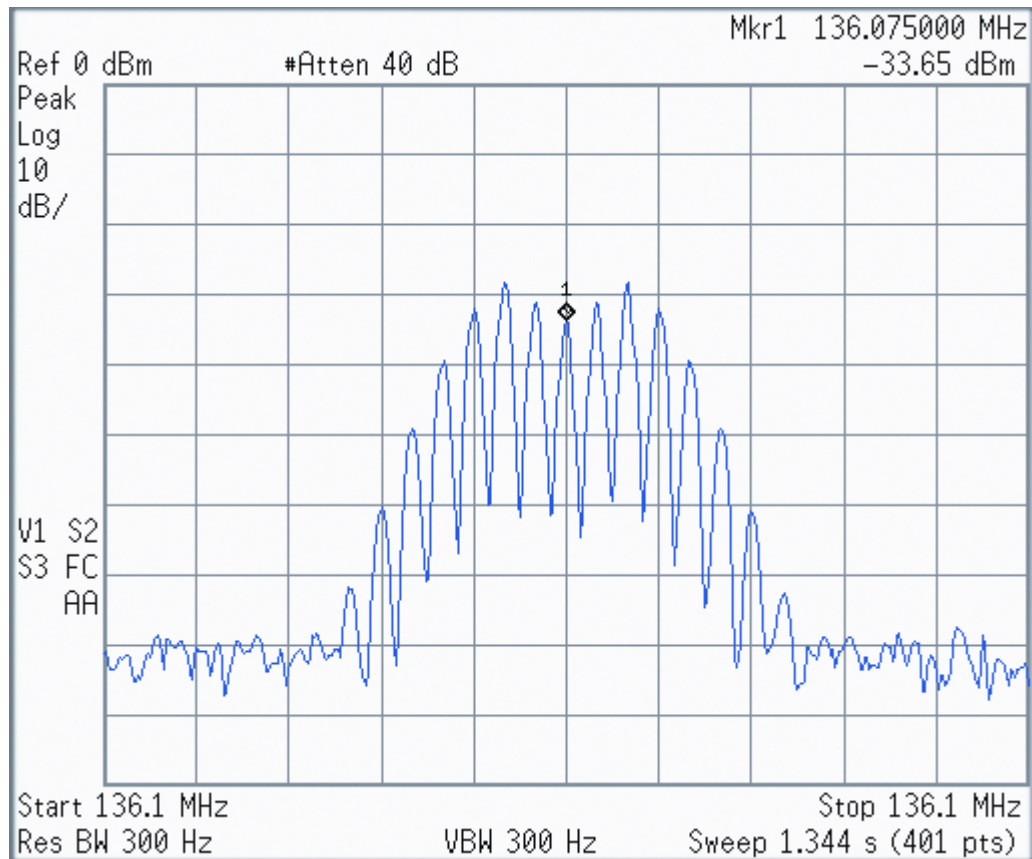

Probe point: C1.

Typical RX signal with 1 kHz modulation. Display shows modulation components of carrier.

7.1.25 PP24 Low-Noise Amplifier Output

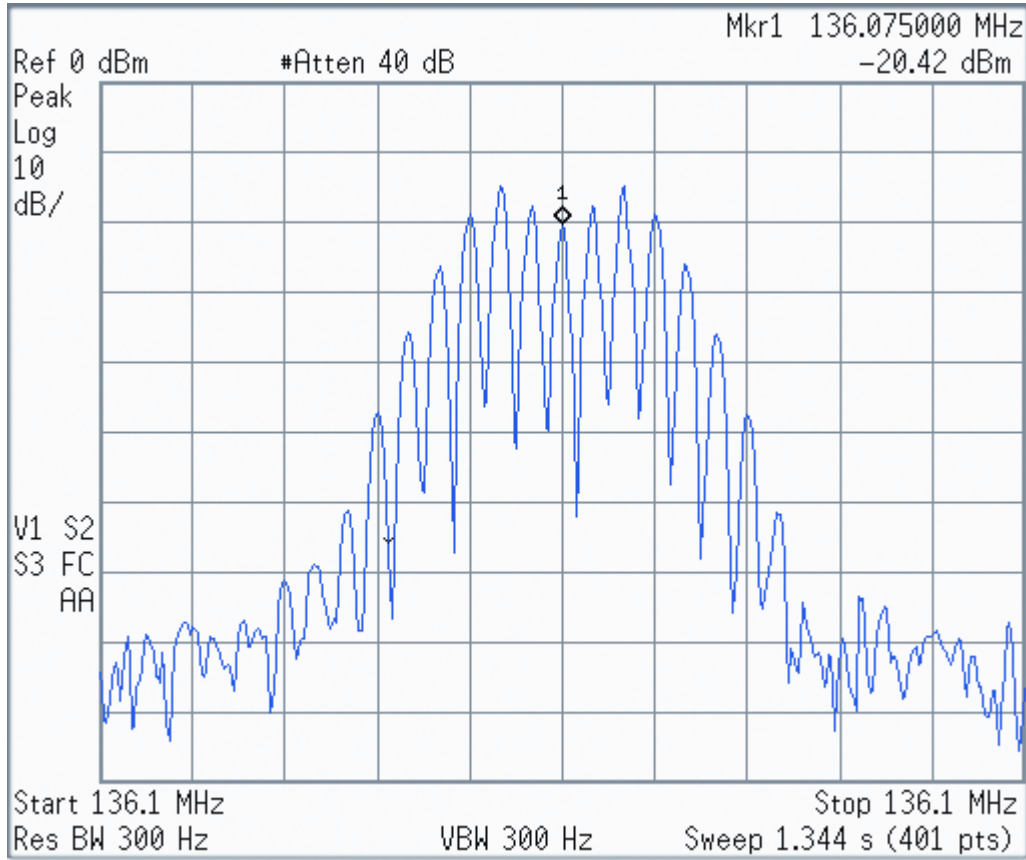

Probe point: C35.

Typical RX signal with 1 kHz modulation. Display shows modulation components of carrier.

7.1.26 PP25 Preselector 2 Output

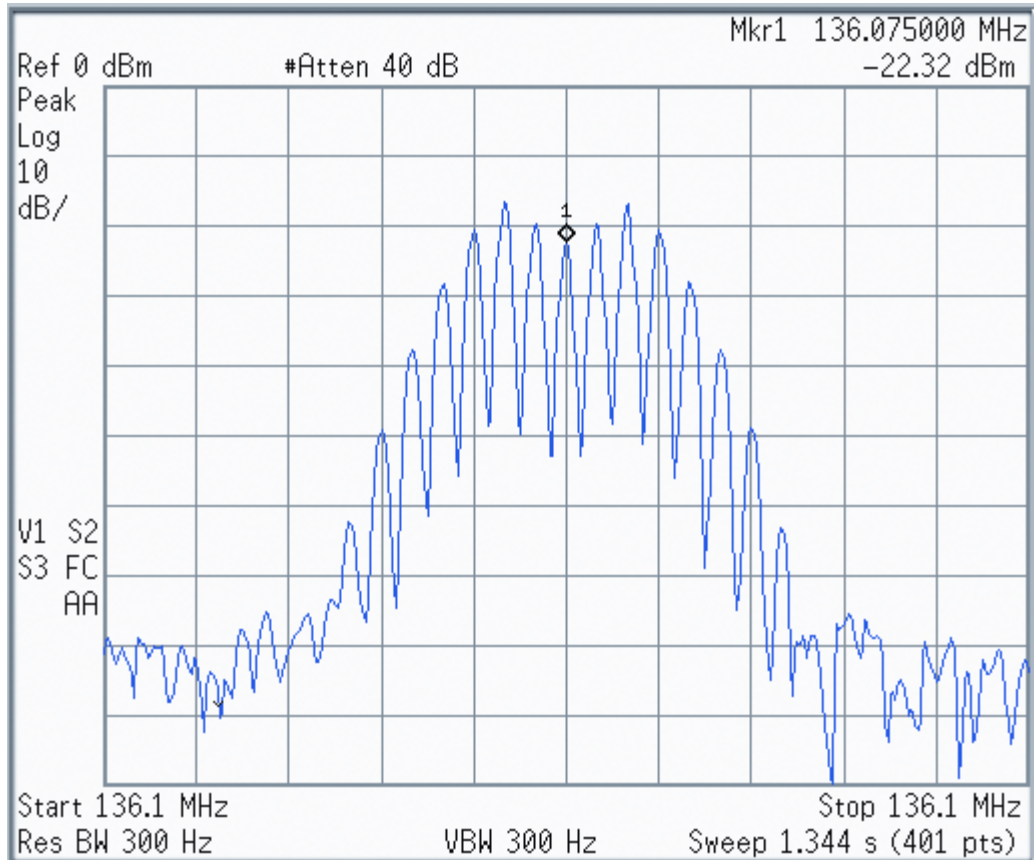

Probe point: C47.

Typical RX signal with 1 kHz modulation. Display shows modulation components of carrier.

7.1.27 PP26 Mixer Out (IF)

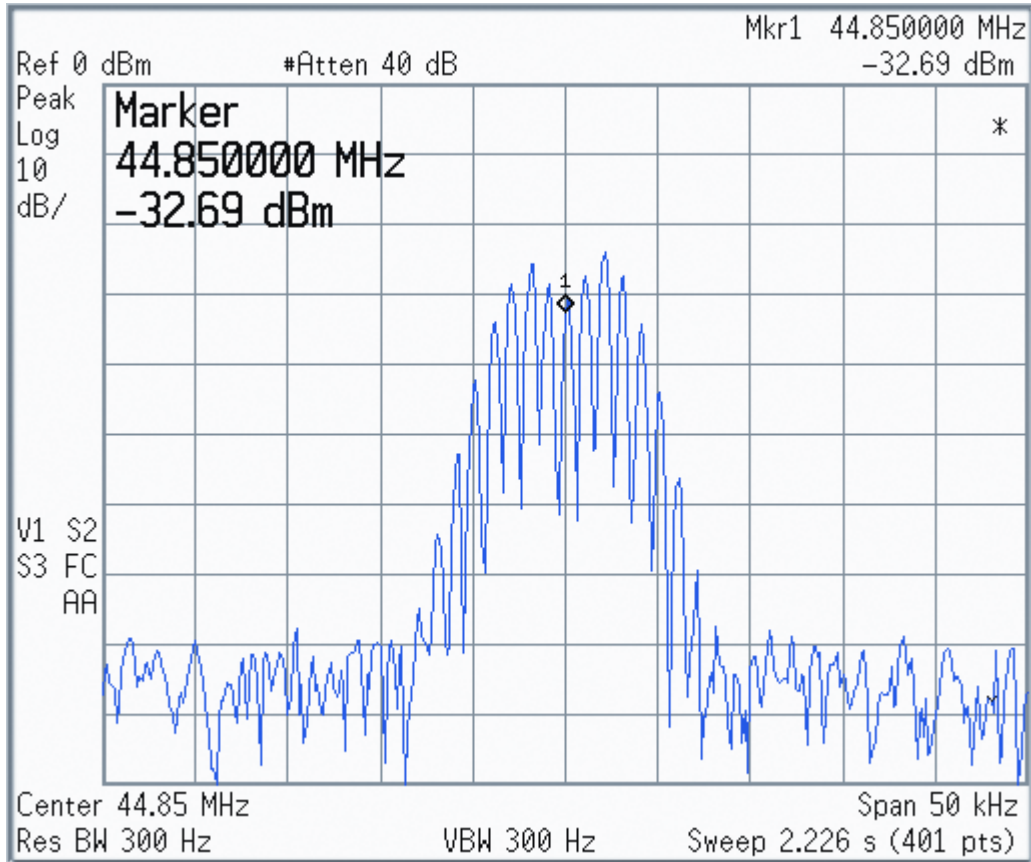

Probe point: C68.

Typical RX signal with 1 kHz modulation. Display shows modulation components of carrier.

7.1.28 PP27 Crystal Filter Out

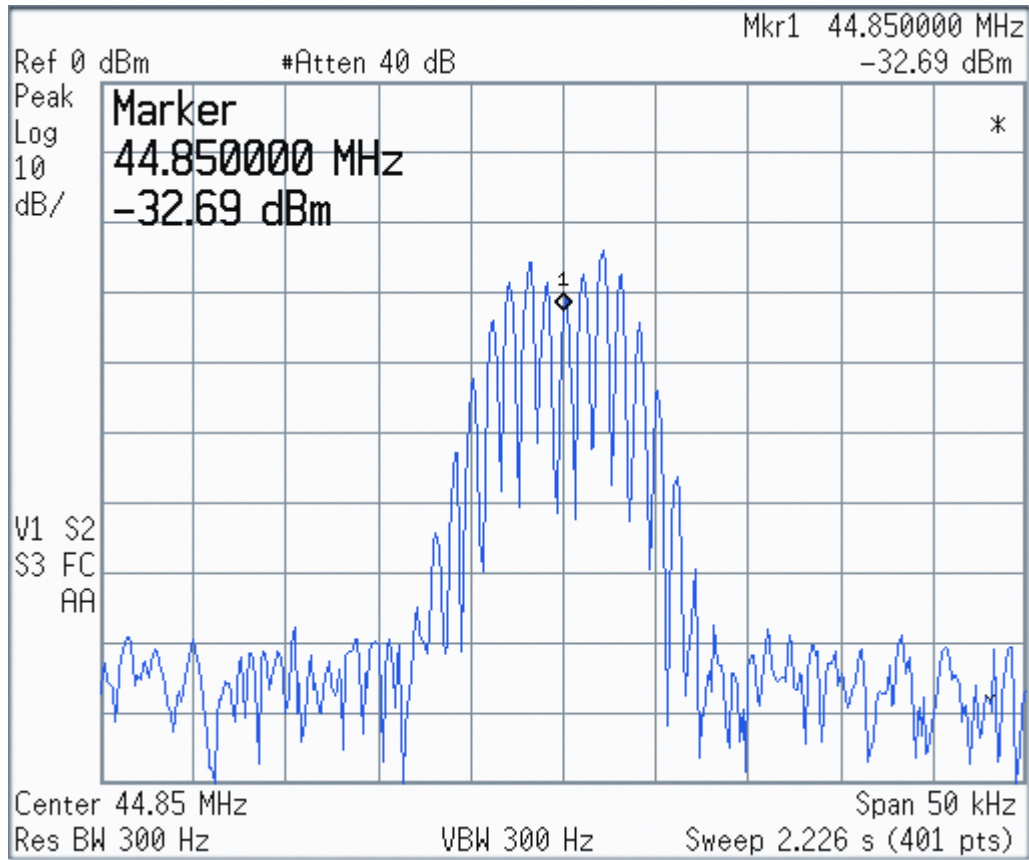

Probe point: L56.

7.1.29 PP28 Abacus Analog 3V

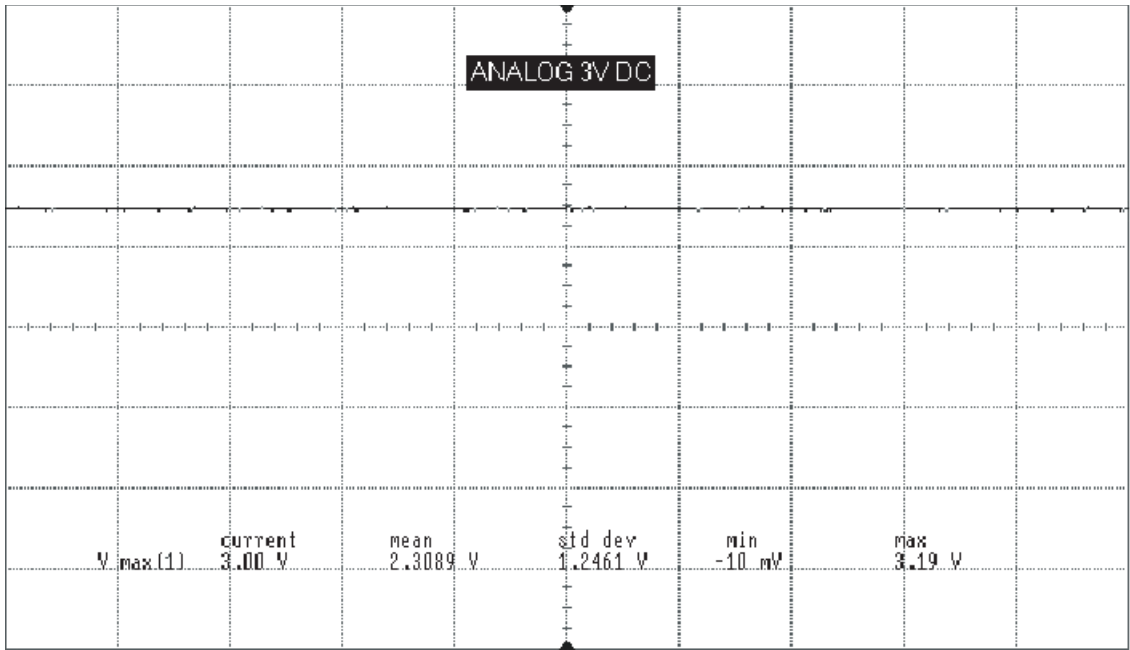

Probe point: U501, pin 5.

7.1.30 PP29 2nd LO Control Voltage

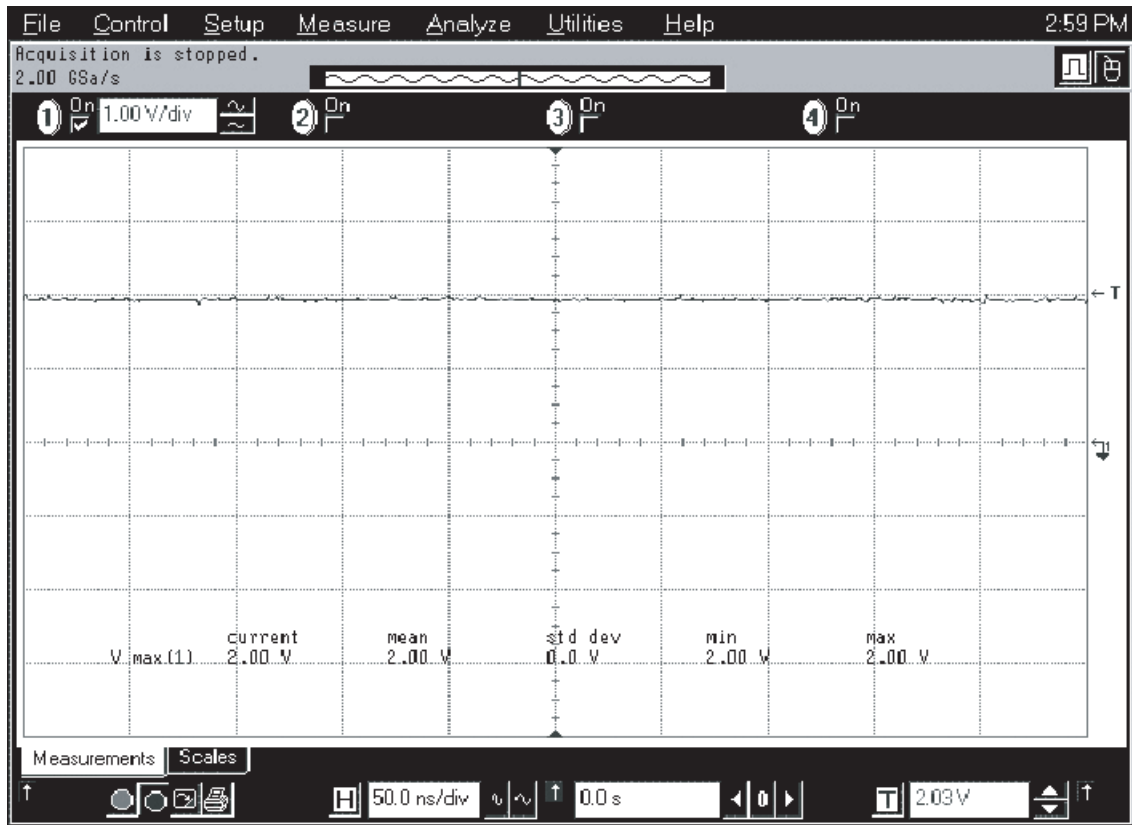

Probe point: U401, pin 38 (located under shield).

7.1.31 PP30 2nd LO VCO Buffer Output

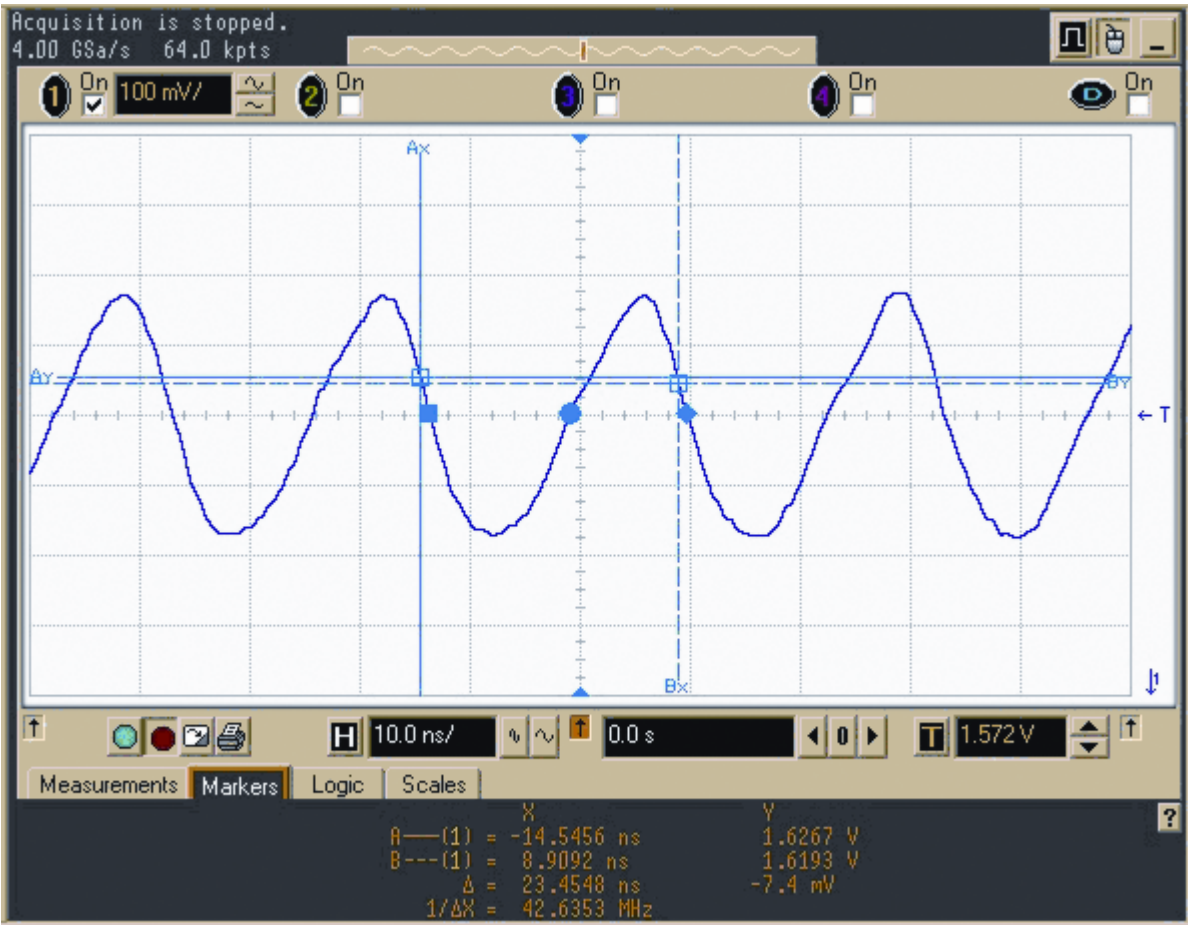

Probe point: C433.

7.1.32 PP31 Analog 5V DC

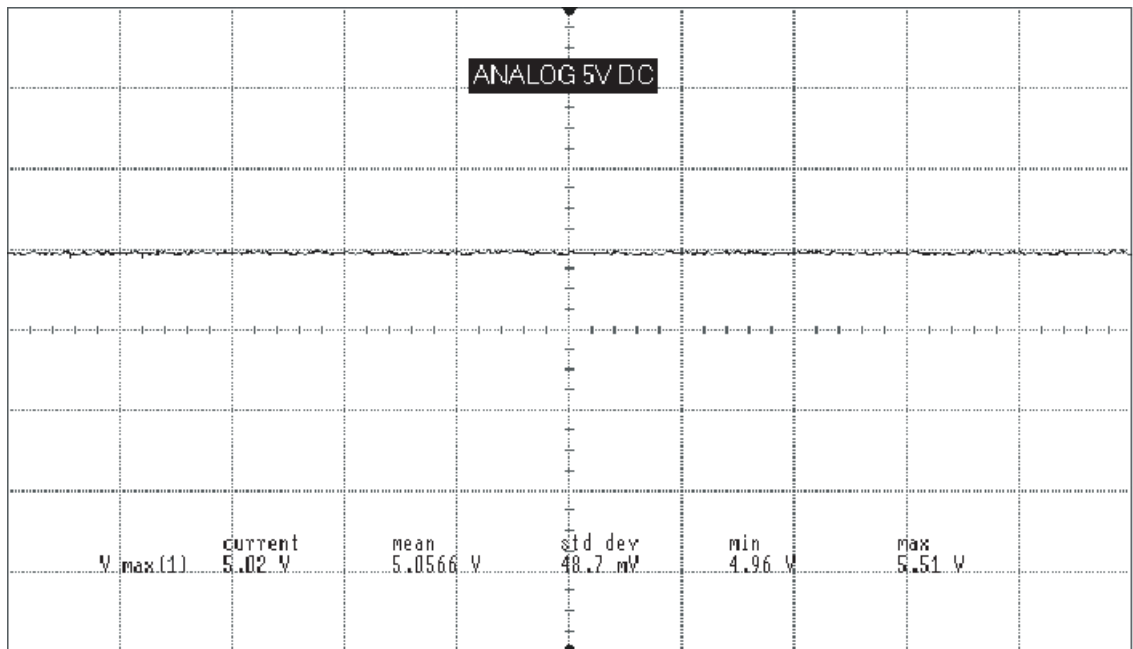

Probe point: U500, pin 5.

7.1.33 PP32 Abacus Digital 3V

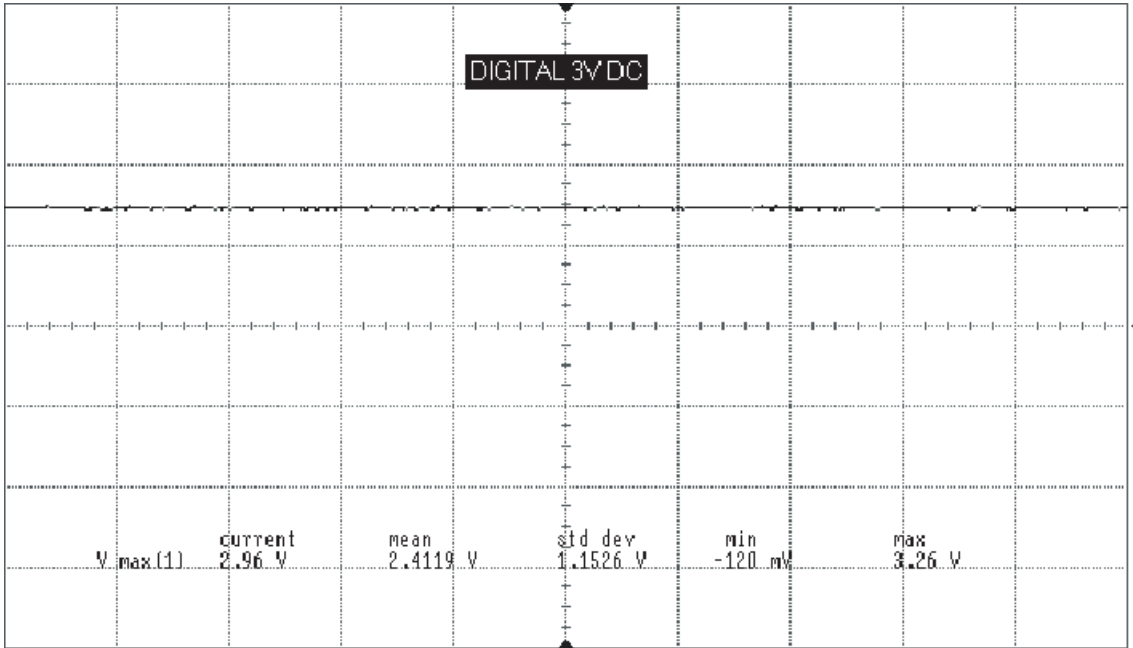

Probe point: U502, pin 5.

7.1.34 TX Audio 1 kHz Tone

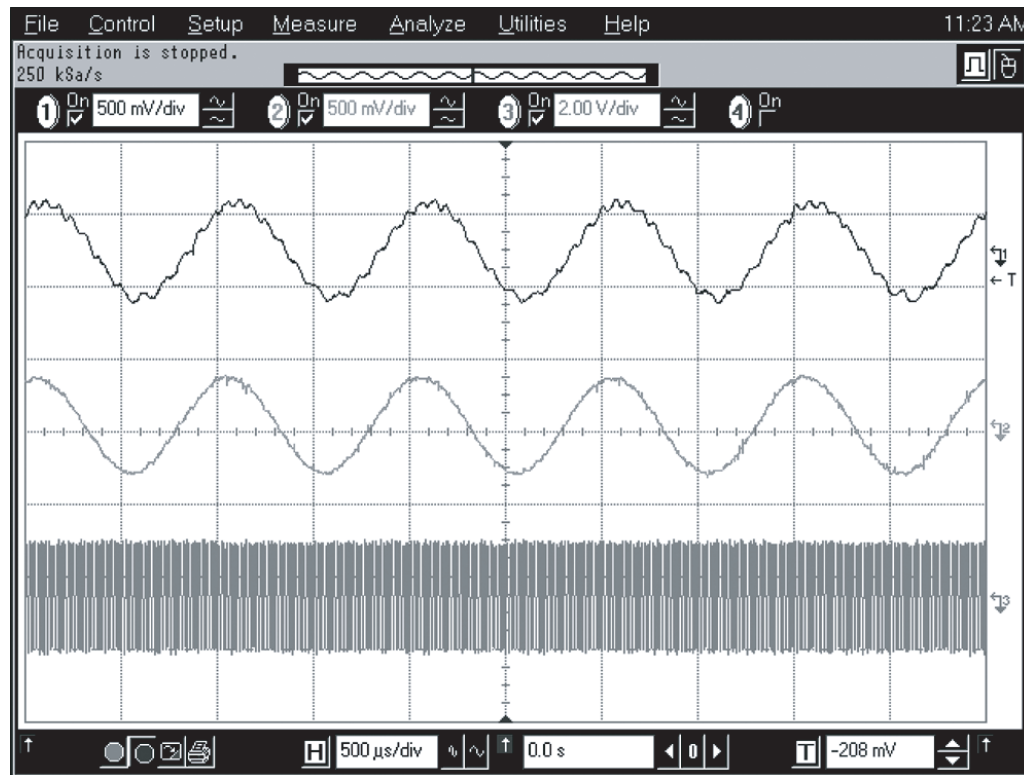

Trace 1: TP23 Mod In (640 mVp-p 1 kHz tone 1.5 Vdc)

Trace 2: U201, pin 1 (620 mVp-p 1 kHz tone)

Trace 3: FL200, pin 8 (1.2 MHz square wave 0 to 3 V)

Note: Transmit audio 1 kHz tone, which provides 3 kHz deviation.

7.1.35 16.8 MHz Buffer Input and Output

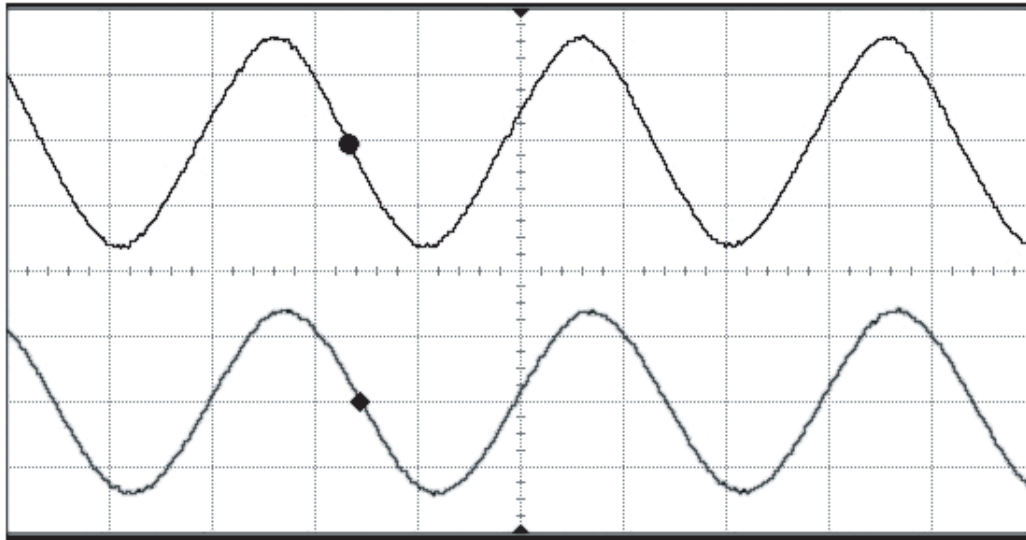

Acquisition Sampling mode real time Normal
 Memory depth automatic 64000 pts
 Sampling rate automatic Sampling rate 4.00 GSa/s
 Averaging off Interpolation on

Channel 1 Scale 300 mV/ Offset 1.546 V
 Coupling DC Impedance 1M Ohm

Channel 4 Scale 400 mV/ Offset 2.154 V
 Coupling DC Impedance 1M Ohm

Time base Scale 20.0 ns/ Position 0.0 s Reference center

Trigger Mode edge Sweep auto
 Sensitivity normal Holdoff time 50 ns Coupling DC
 Source channel 4 Trigger level 1.354 V Slope rising

Measure	V p-p(1)	Frequency(1●)	V p-p(4)	Frequency(4*)
Current	983 mV	16.82001 MHz	1.137 V	16.83329 MHz
Mean ?	977.0 mV	? 16.815154 MHz	1.1378 V	16.802593 MHz
Min ?	57 mV	? 16.63969 MHz	1.008 V	16.65859 MHz
Max ?	993 mV	? 25.09409 MHz	1.237 V	16.94801 MHz
Range ?	936 mV	? 8.454399 MHz	229 mV	289.41886 kHz
Std Dev ?	39.6 mV	? 357.28113 kHz	14.5 mV	53.754484 kHz
# of Meas	551	551	553	553
Edge Dir		Falling		Falling

Trace 1: Buffer input at R729.

Trace 2: Buffer output at C726.

7.1.36 32.768 kHz Clock Outputs

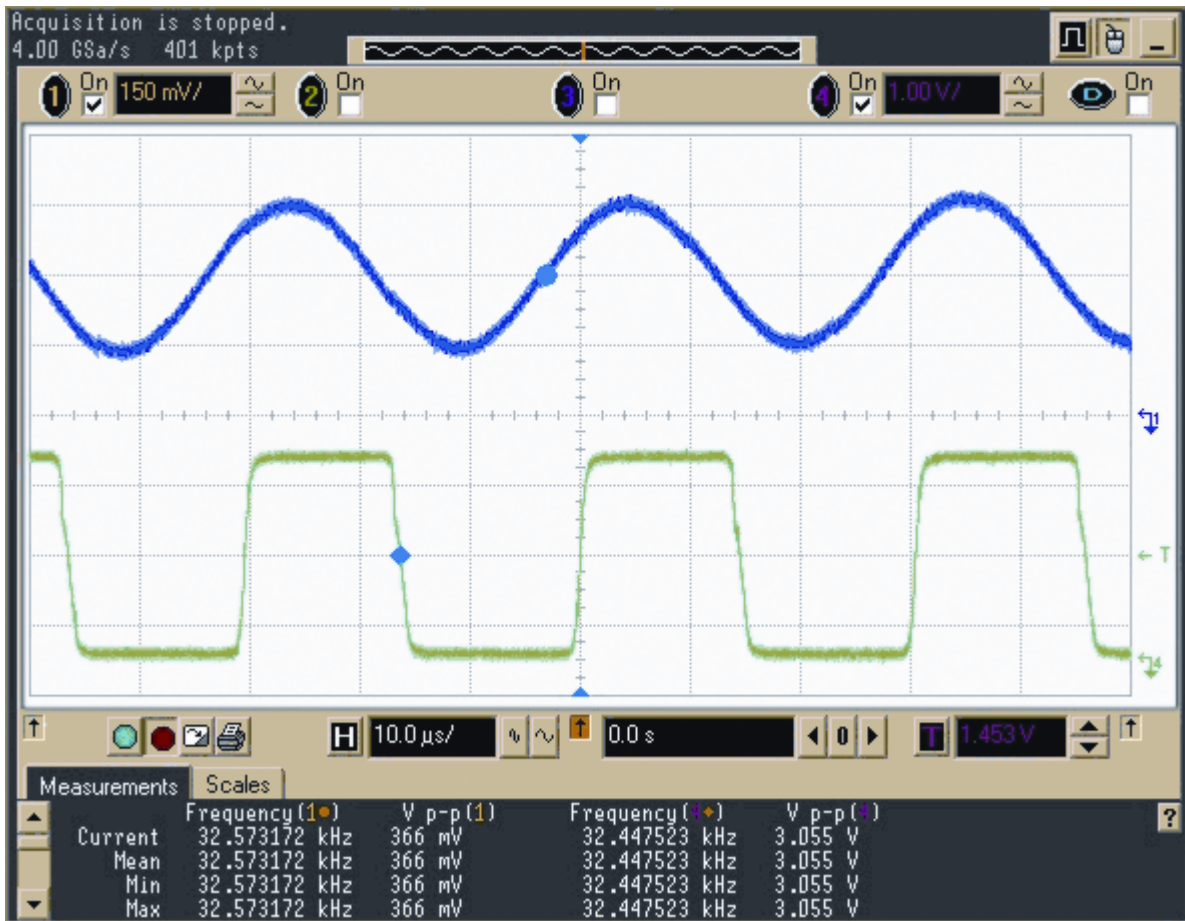

Trace 1: Output at C743.

Trace 2: Output at U712, pin 4.

7.1.37 SPI B Data

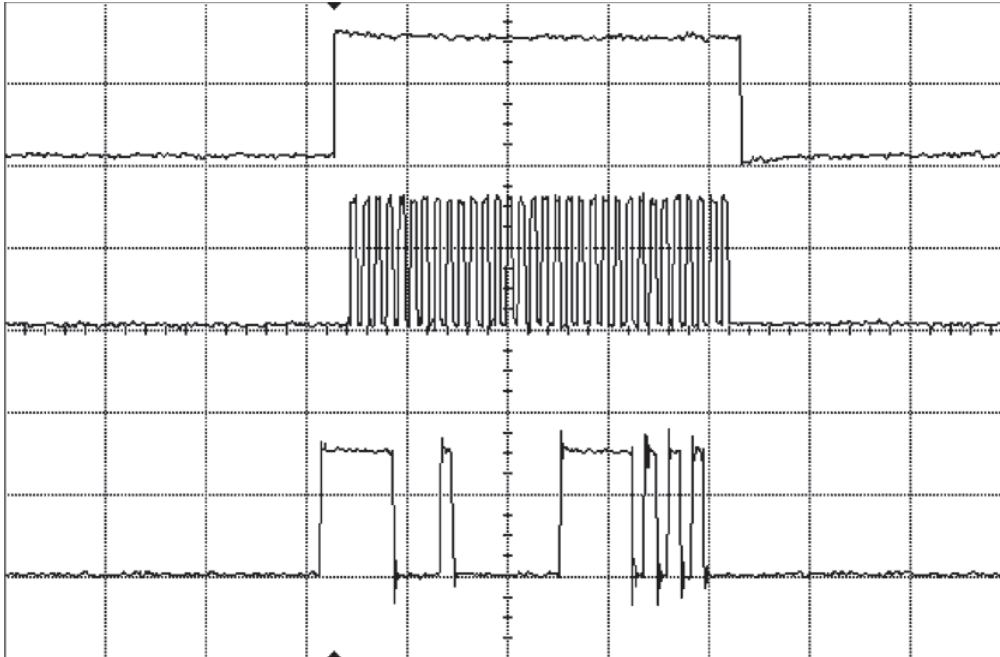

Acquisition	Sampling mode real time Configuration 4GSa/s Memory depth automatic Memory depth 1004pts Sampling rate automatic Sampling rate 50.0 MSa/s Averaging off 9-bit B'W Filter off Interpolation on
Channel 1	Scale 1.99 V/div Offset -4.21 V Coupling DC Impedance 1M Ohm Attenuation 10.00 : 1 Atten units ratio Skew 0.0 s Ext adapter None Ext coupler None Ext gain 1.00E+00 Ext offset 0.0E+00
Channel 2	Scale 2.00 V/div Offset -260 mV Coupling DC Impedance 1M Ohm Attenuation 10.00 : 1 Atten units ratio Skew 0.0 s Ext adapter None Ext coupler None Ext gain 1.00E+00 Ext offset 0.0E+00
Channel 3	Scale 2.00 V/div Offset 5.76 V Coupling DC Impedance 1M Ohm Attenuation 10.00 : 1 Atten units ratio Skew 0.0 s Ext adapter None Ext coupler None Ext gain 1.00E+00 Ext offset 0.0E+00
Time base	Scale 2.00 μs/div Position 3.454546 μs Reference center
Trigger	Mode edge Sweep auto Hysteresis normal Holdoff time 60 ns Coupling DC Source channel 1 Trigger level 810 mV Slope rising

Trace 1: MAKO chip enable, R767 (not active high)
Trace 2: SPI data clock, C619
Trace 3: SPI data to MAKO, C617.

7.1.38 RX Serial Audio Port (SAP)

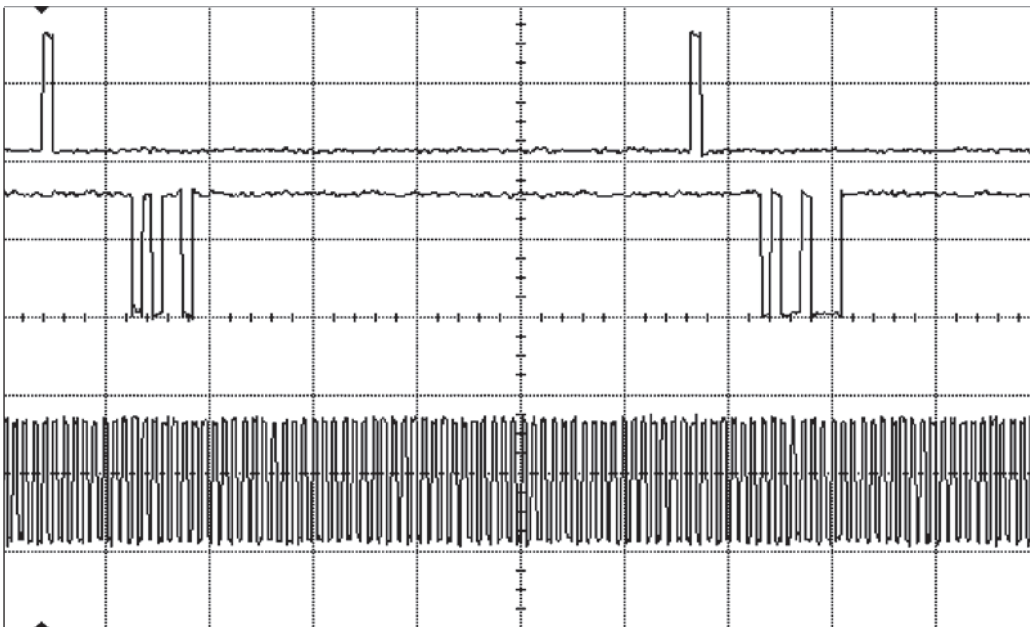

Acquisition	Sampling mode real time Configuration 4GSa/s Memory depth automatic Memory depth 1004pts Sampling rate automatic Sampling rate 5.00 MSa/s Averaging off 9-bit BW Filter off Interpolation on
Channel 1	Scale 1.99 V/div Offset -4.21 V Coupling DC Impedance 1M Ohm Attenuation 10.00 : 1 Atten units ratio Skew 0.0 s Ext adapter None Ext coupler None Ext gain 1.00E+00 Ext offset 0.0E+00
Channel 2	Scale 2.00 V/div Offset -210 mV Coupling DC Impedance 1M Ohm Attenuation 10.00 : 1 Atten units ratio Skew 0.0 s Ext adapter None Ext coupler None Ext gain 1.00E+00 Ext offset 0.0E+00
Channel 3	Scale 2.00 V/div Offset 5.55 V Coupling DC Impedance 1M Ohm Attenuation 10.00 : 1 Atten units ratio Skew 0.0 s Ext adapter None Ext coupler None Ext gain 1.00E+00 Ext offset 0.0E+00
Time base	Scale 20.0 μ s/div Position 92.181816 μ s Reference center
Trigger	Mode edge Sweep auto Hysteresis normal Holdoff time 60 ns Coupling DC Source channel 1 Trigger level 810 mV Slope rising

Note: TX is identical, except the data is probed at test point "TX".

Trace 1: 8 kHz frame sync (each word is 13 bits after falling edge of FSYNC)

Trace 2: SAP data at R626 (audio data from MAKO CODEC to Patriot DSP)

Note: Transmit is identical, except data acquired at R625

Trace 3: 512kHz bit clock at R616. (Codec_DCLK).

7.1.39 PP33 SPI Data

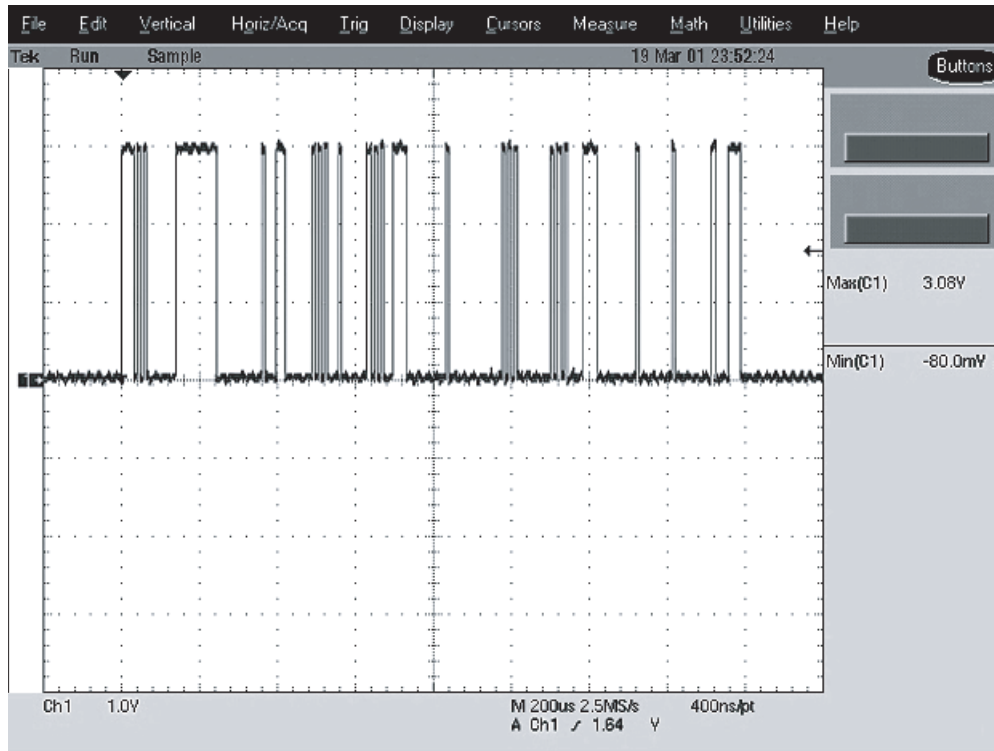

Probe Point: R802.

7.1.40 PP34 SPI CLK

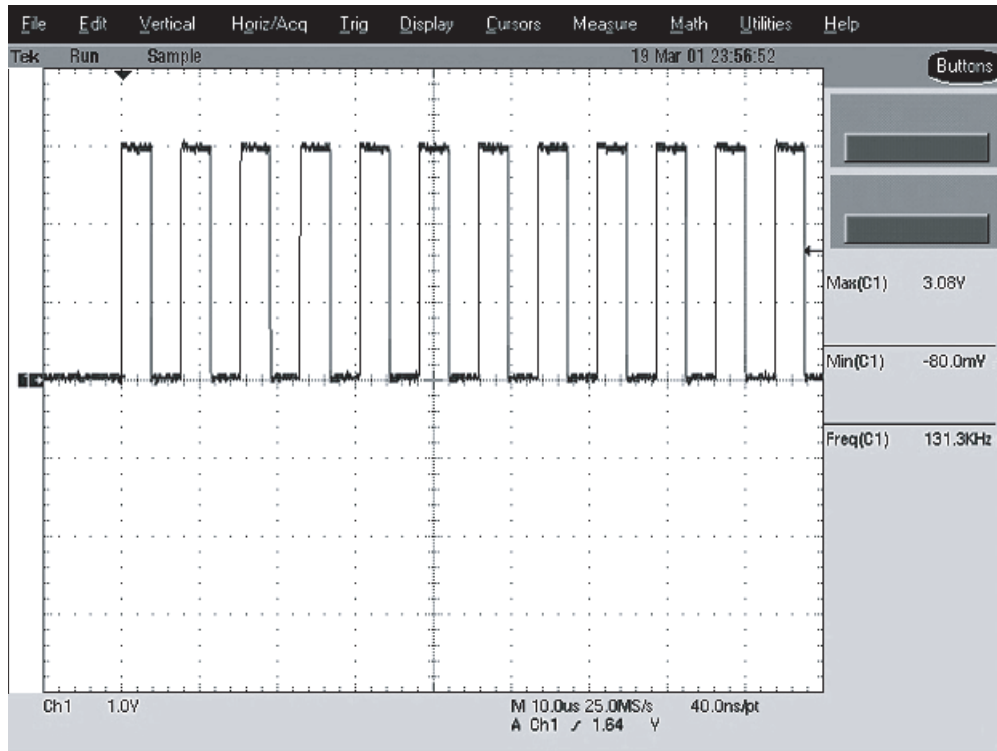

Probe Point: R803.

7.1.41 PP35 Universal Chip Select

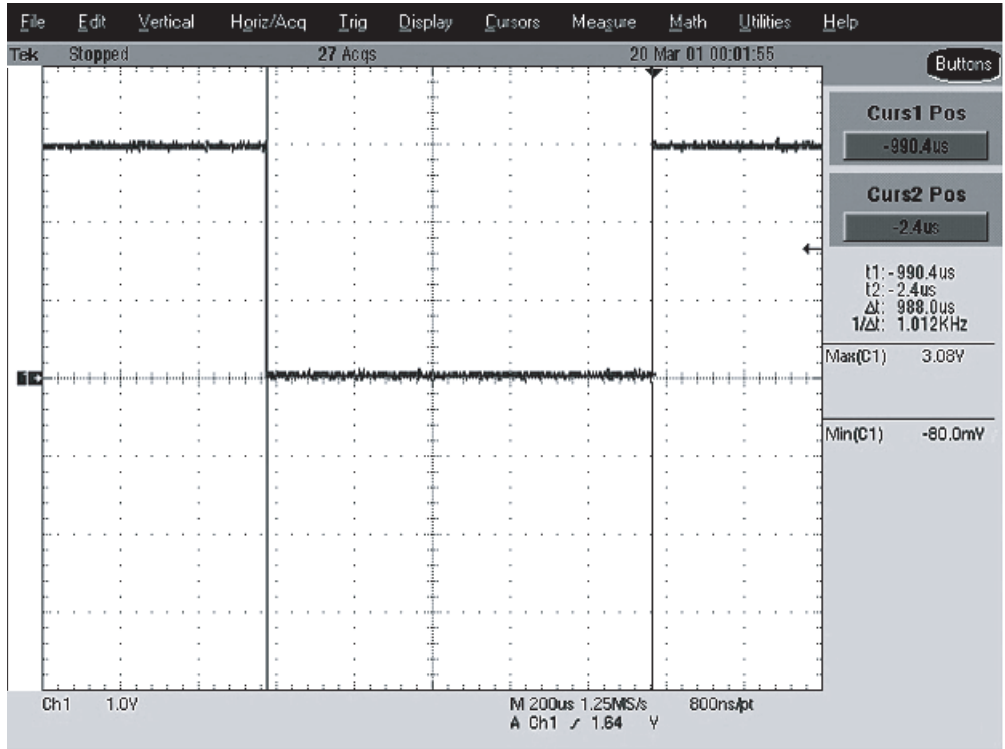

Probe Point: U102, pin 29 (located under shield).

7.1.42 PP36 Abacus Chip Select

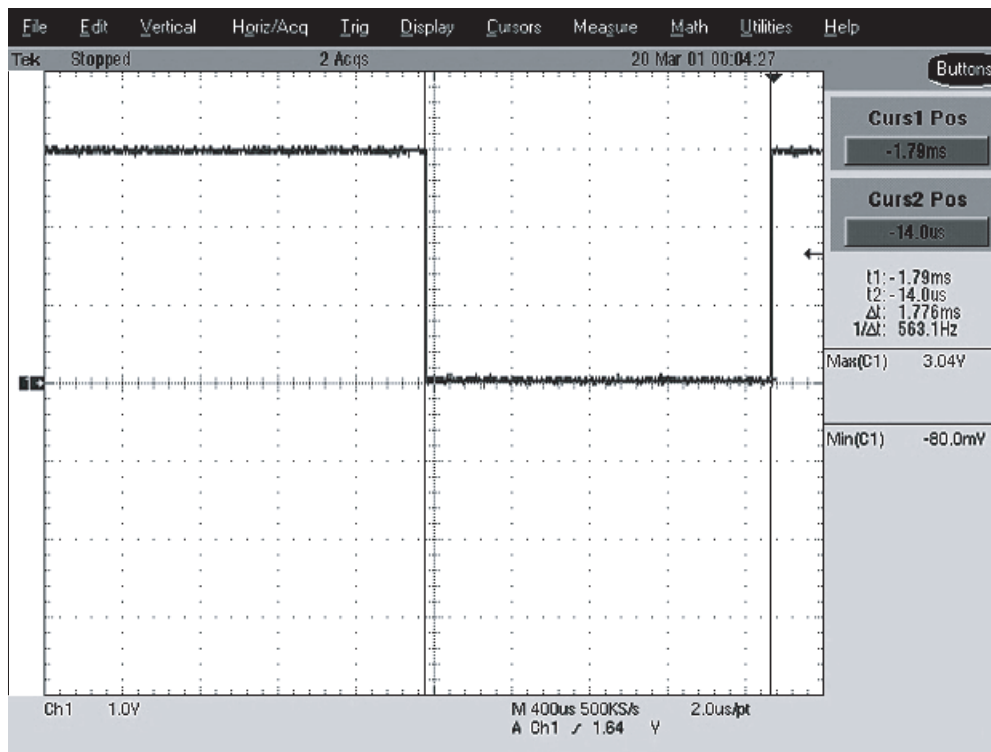

Probe Point: U401, pin 25 (located under shield).

7.1.43 TP37 RX SSI Data

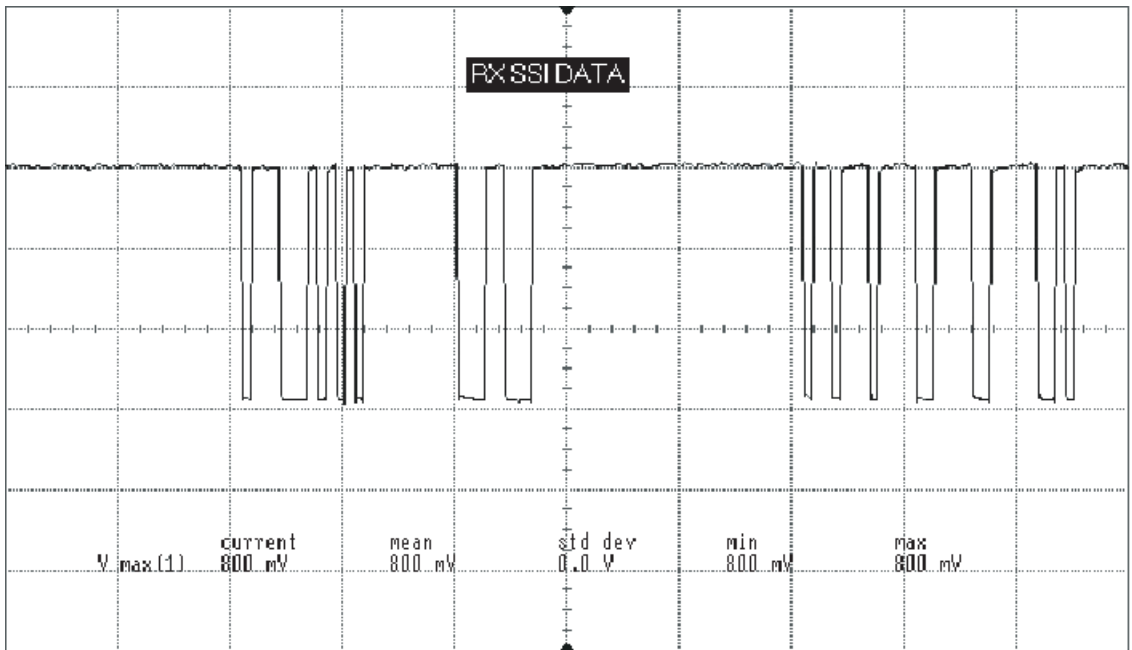

Test Point: SSI_D (Test Point).

7.1.44 TP38 RX SSI Clock

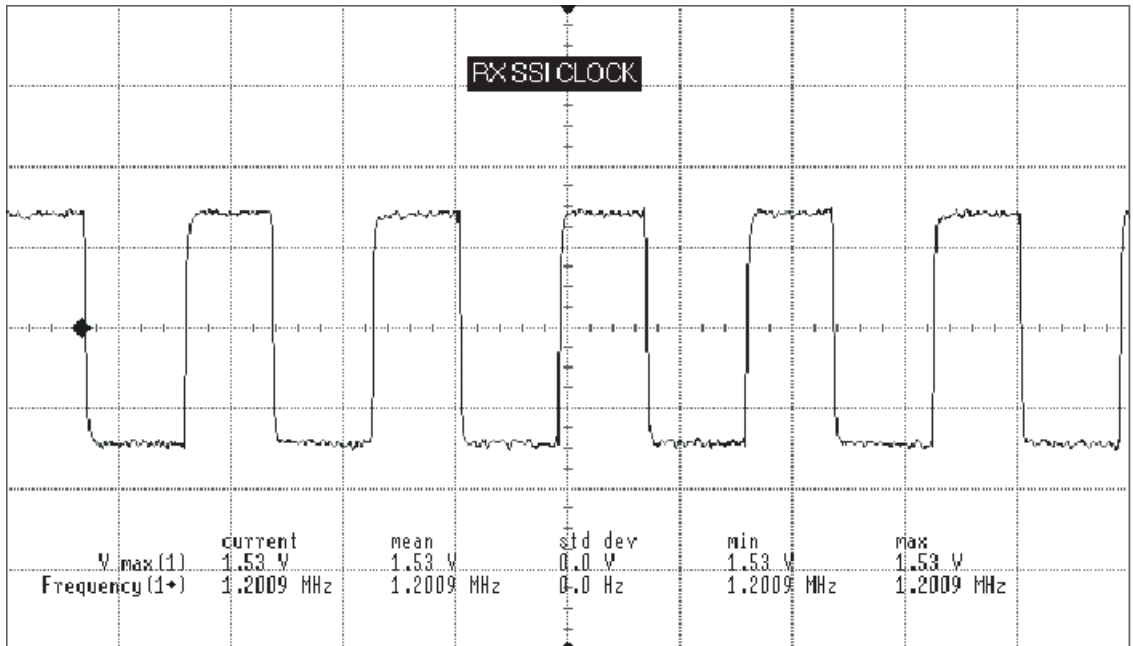

Test Point: SSI_CLK (Test Point).

7.1.45 TP39 RX SSI Frame Sync

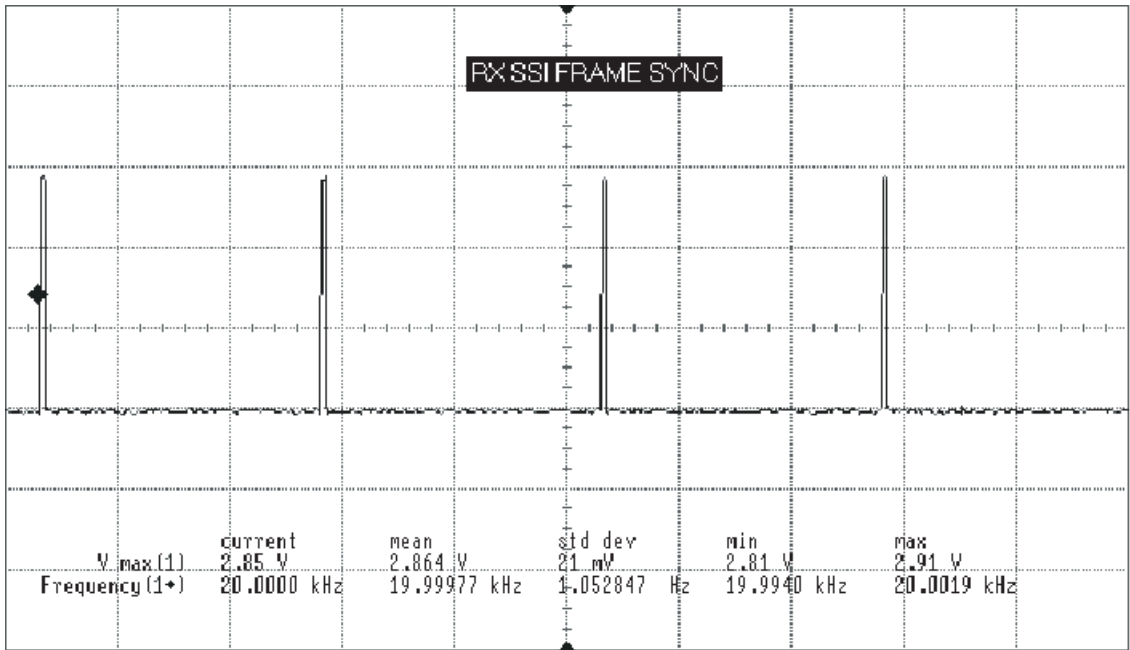

Test Point: SSI_FS (Test Point).

Test Point: TP401.

Chapter 7.2 UHF1 Troubleshooting Waveforms

7.2.1 Introduction

This chapter contains images of waveforms that might be useful in verifying operation of certain parts of the circuitry. These waveforms are for reference only; the actual data depicted will vary depending upon operating conditions. This manual is to be used in conjunction with the ASTRO XTS 2500/ XTS 2500I Digital Portable Radios Basic Service Manual (Motorola part number 6816984H01), which uses the pass/fail service approach to radio problems.

7.2.2 List of Waveforms

[Table 7.2-1](#) lists each waveform and the page on which the waveform can be found.

Table 7.2-1. List of Waveforms

Waveform	Page No.	Waveform	Page No.
Antenna Input	7.2-6	Low-Noise Amplifier Output	7.2-27
TX Signal at Harmonic Filter Input	7.2-7	Preselector 2 Output	7.2-28
Coupler RF Out	7.2-8	Mixer Out (IF)	7.2-29
TX Signal at PA	7.2-9	Crystal Filter Out	7.2-30
Coupler RF Feedback to PCIC	7.2-10	Abacus Analog 3V	7.2-31
PCIC Control Voltage	7.2-11	2nd LO Control Voltage	7.2-32
TX LO	7.2-12	2nd LO VCO Buffer Output	7.2-33
Higher Level Voltage Multiplier	7.2-13	Abacus Digital 3V	7.2-35
Superfilter Output	7.2-14	TX Audio 1 kHz Tone	7.2-36
Prescaler Input to FracN Synthesizer	7.2-15	16.8 MHz Buffer Input and Output	7.2-37
Reference Crystal Output	7.2-16	32.768 kHz Clock Outputs	7.2-38
Mod In	7.2-17	SPI B Data	7.2-39
1st LO Control Voltage	7.2-18	RX Serial Audio Port (SAP)	7.2-40
VCO Output	7.2-19	SPI Data	7.2-41
Frequency Out (16.8 MHz)	7.2-21	SPI CLK	7.2-42
RX RF Input at Antenna Switch	7.2-22	Universal Chip Select	7.2-43
Antenna Switch Bias	7.2-23	Abacus Chip Select	7.2-44
Preselector Tuning Voltage	7.2-24	RX SSI Data	7.2-45
RX RF Input after Antenna Switch	7.2-25	RX SSI Clock	7.2-46
Analog 5V	7.2-25	RX SSI Frame Sync	7.2-47
Preselector 1 Output	7.2-26		

7.2.3 RF Test Points

The following RF block diagram and accompanying table (Table 7.2-2) shows the location of key probe points (PP) and test points (TP) for the XTS 2500/XTS 2500I radio.

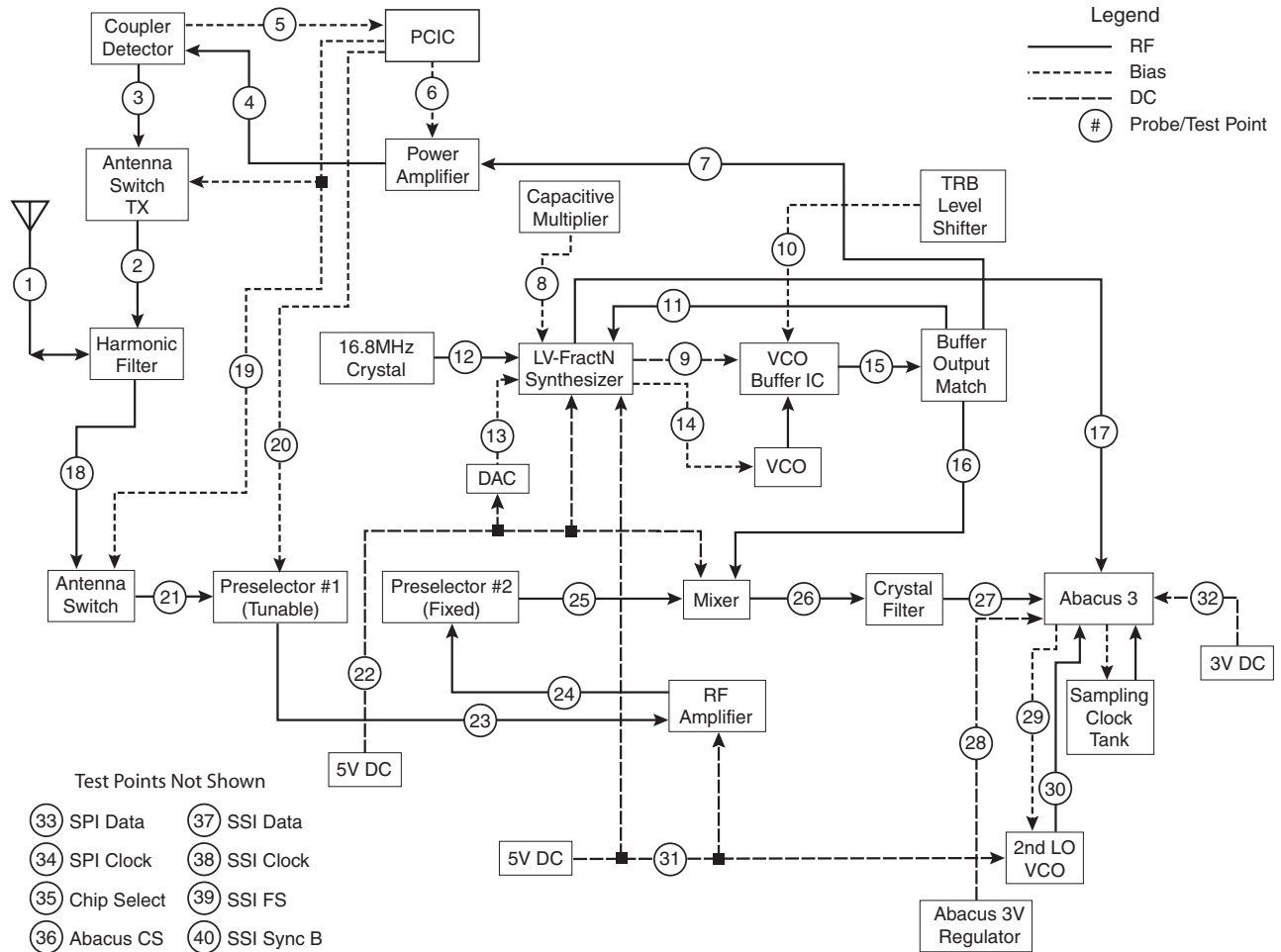

MAEPF-27353-O

Figure 7.2-1. RF Block Diagram Test Points

Table 7.2-2. RF Block Diagram Probe/Test Points

PP/TP	Name	Location	Under RF Shield?	Page
1	Antenna Input	J101, pin 5	No.	7.2-6
2	TX Signal at Harmonic Filter Input	C192	Yes.	7.2-7
3	Coupler RF Out	U103, pin 1	No.	7.2-8
4	TX Signal at PA	Q101, pin 3	No.	7.2-9
5	Coupler RF Feedback to PCIC	TP160	No.	7.2-10
6	PCIC Control Voltage	TP_146	No.	7.2-11
7	TX LO	R289	No.	7.2-12
8	Higher Level Voltage Multiplier	C210	Yes.	7.2-13
9	Superfilter Output	SF_TP	Yes.	7.2-14
11	Prescaler Input to FracN Synthesizer	TP23	Yes.	7.2-15
12	Reference Crystal Output	R729 and C726	No.	7.2-16
13	Mod In	TP36	No.	7.2-17
14	1st LO Control Voltage	VC_TP	No.	7.2-18
15	VCO Output	R266(Rx), R289(Tx) and TP23(prescaler)	Yes.	7.2-19
17	Frequency Out (16.8 MHz)	16out	No.	7.2-21
18	RX RF Input at Antenna Switch	D20, Pin 1	No.	7.2-22
20	Preselector Tuning Voltage	C139	No.	7.2-24
22	Analog 5V	U500, pin 5	No.	7.2-25
23	Preselector 1 Output	U2, Pin 3	Yes.	7.2-26
24	Low-Noise Amplifier Output	C35	Yes	7.2-27
25	Preselector 2 Output	TPOO	Yes	7.2-28
26	Mixer Out (IF)	T53, Pin 4	Yes.	7.2-29
27	Crystal Filter Out	R38	Yes	7.2-30
28	Abacus Analog 3V	U501, pin 5	No.	7.2-31
29	2nd LO Control Voltage	U401, pin 38	Yes.	7.2-32
30	2nd LO VCO Buffer Output	C433	Yes.	7.2-33
31	Analog 5V	U500, pin 5	No.	7.2-34
32	Abacus Digital 3V	U502, pin 5	No.	7.2-35
33	SPI Data	R802	No.	7.2-41
34	SPI CLK	R803	No.	7.2-42
35	Universal Chip Select	U102, pin 29	No	7.2-43
36	Abacus Chip Select	U401, pin 25	Yes.	7.2-44
37	RX SSI Data	SSI_D	No.	7.2-45

Table 7.2-2. RF Block Diagram Probe/Test Points (Continued)

PP/TP	Name	Location	Under RF Shield?	Page
38	RX SSI Clock	SSI_CLK	No.	7.2-46
39	RX SSI Frame Sync	SSI_FS	No.	7.2-47

PP = Probe Point
TP = Test Point

Note: For test/probe points indicated with the SH prefix, use an HP 85024A High Frequency Probe to detect a signal. The probe should be placed in center of the hole located on the top of the shield. Make sure the probe does not touch the shield or any other components.

7.2.4 Main Circuit Board RF Shield Locations

Viewed from Side 1

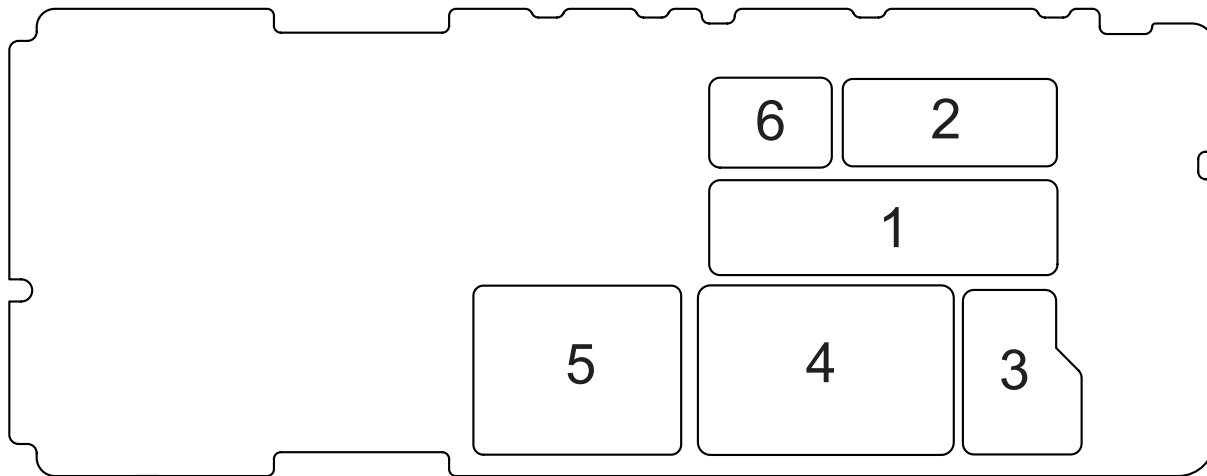

Table 7.2-3. Main Circuit Board Side 1 RF Shields

Item Number	Reference Number	Motorola Part Number	Description
1	SH51	2686700Z02	Shield, Mixer
2	SH402	2686698Z02	Shield, 2nd LO
3	SH102	2686701Z02	Shield, Harmonic Filter
4	SH101	2686702Z02	Shield, TX Driver
5	SH251	2616554H01	Shield, VCO Top
6	SH52	2686699Z02	Shield, Crystal IF

Viewed from Side 2

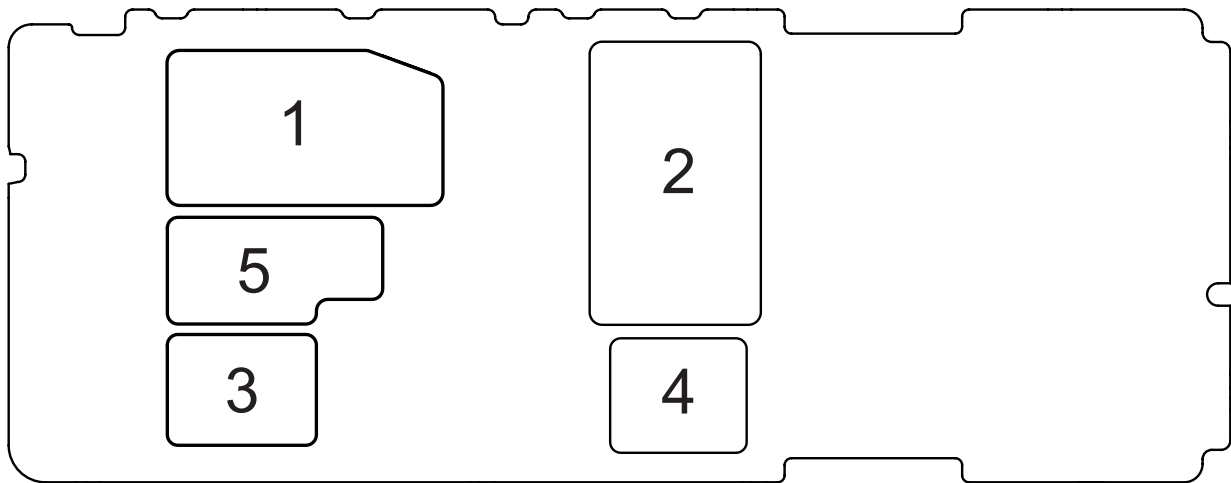
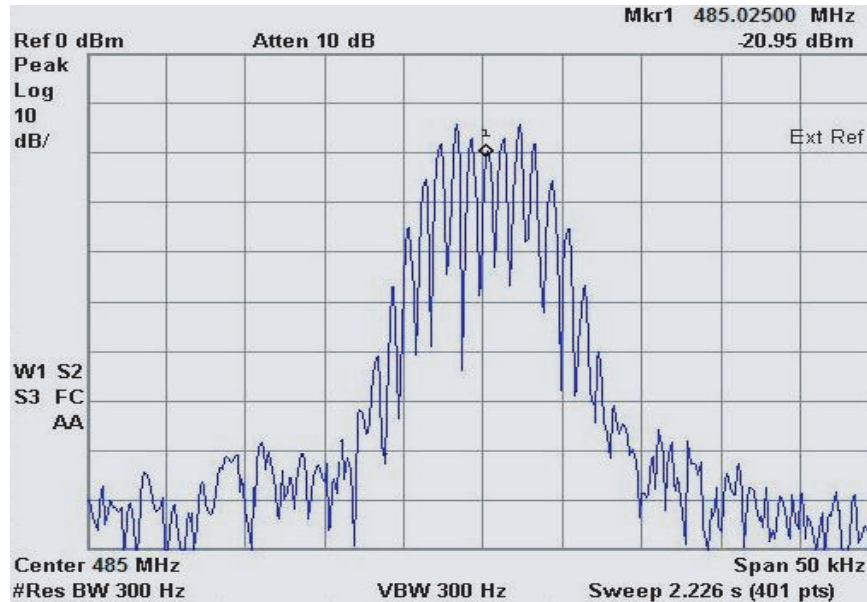
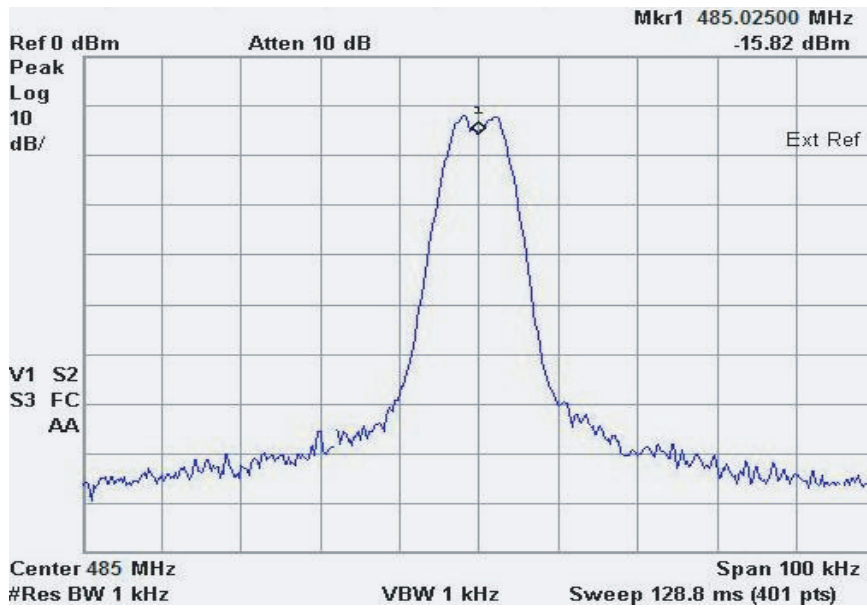

Table 7.2-4. Main Circuit Board Side 2 RF Shields

Item Number	Reference Number	Motorola Part Number	Description
1	SH401	2686706Z02	Shield, ABACUS
2	SH201	2686705Z02	Shield, Synthesizer
3	SH103	2686708Z02	Shield, Coupler Bottom
4	SH252	2616559H01	Shield, VCO Bottom
5	SH1	2686707Z02	Shield, Front End Filter

7.2.5 PP1 Antenna Input



Probe point: J101, pin 5.

Typical RX signal with 1 kHz modulation. Display shows modulation components of carrier.

7.2.6 PP2 TX Signal at Harmonic Filter Input

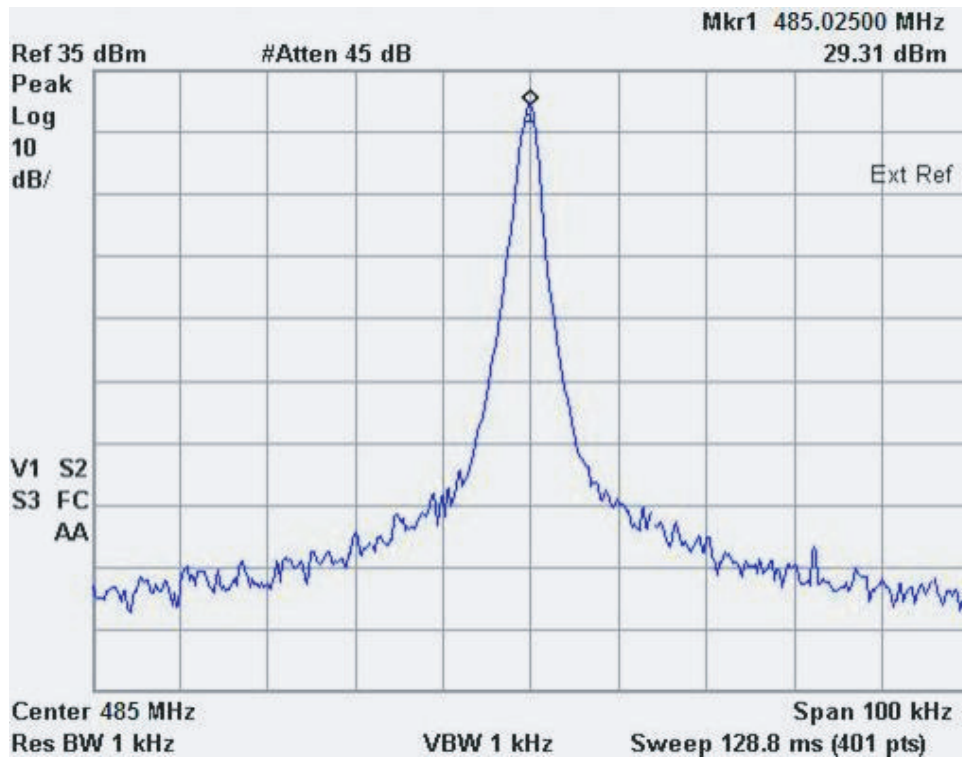

Probe point: C180 (located under shield).

7.2.7 PP3 Coupler RF Out

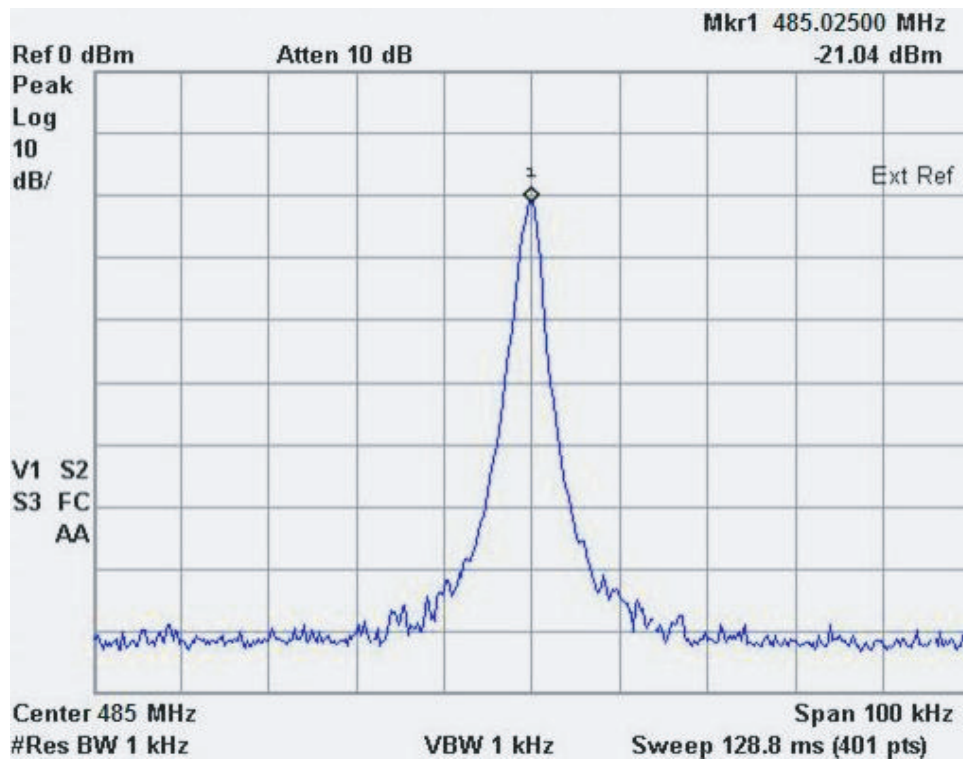

Probe point: U103, pin 1.

7.2.8 PP4 TX Signal at PA

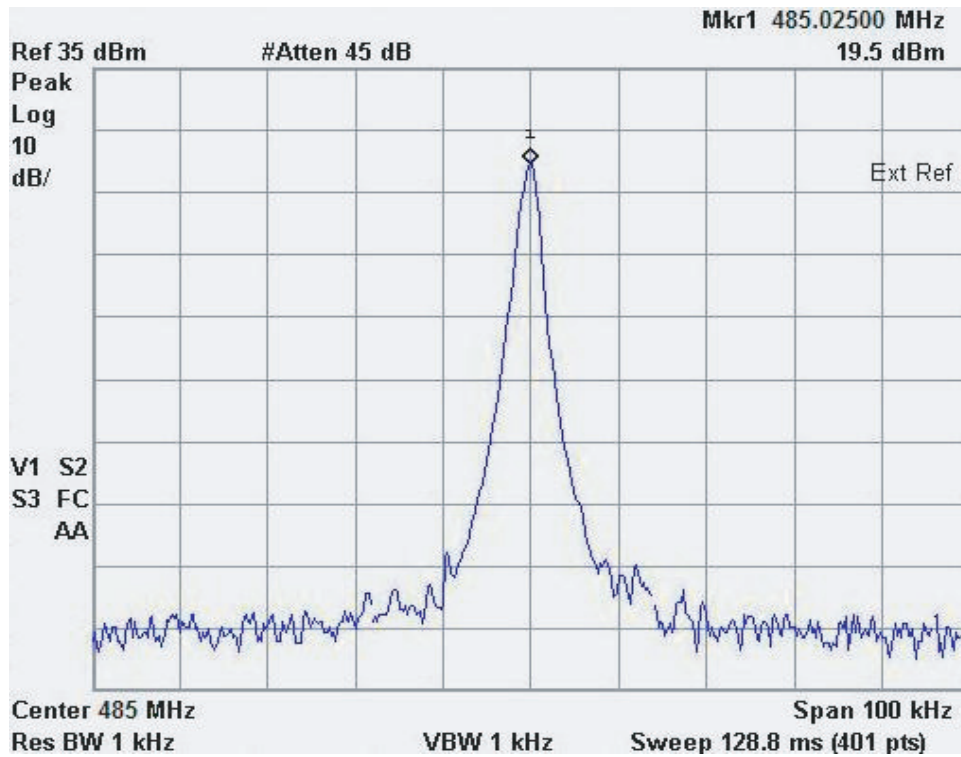

Probe point: Q101, pin 2.

7.2.9 TP5 Coupler RF Feedback to PCIC

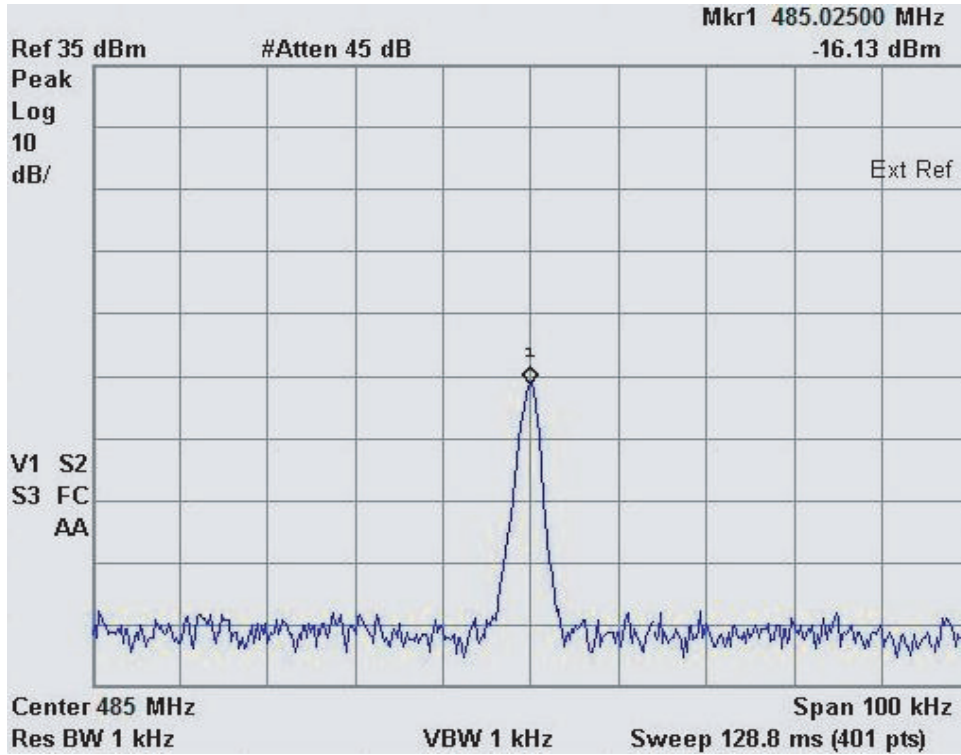

Test point: TP_160.

7.2.10 TP6 PCIC Control Voltage

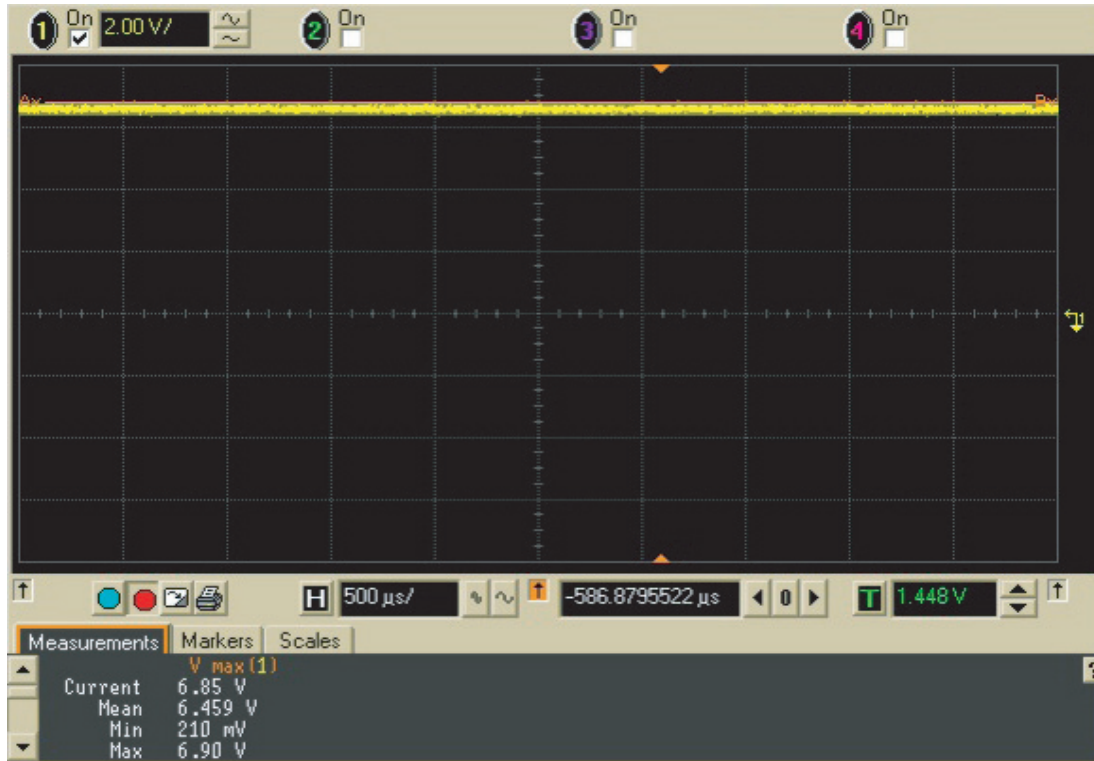

Test point: TP146.

7.2.11 PP7 TX LO

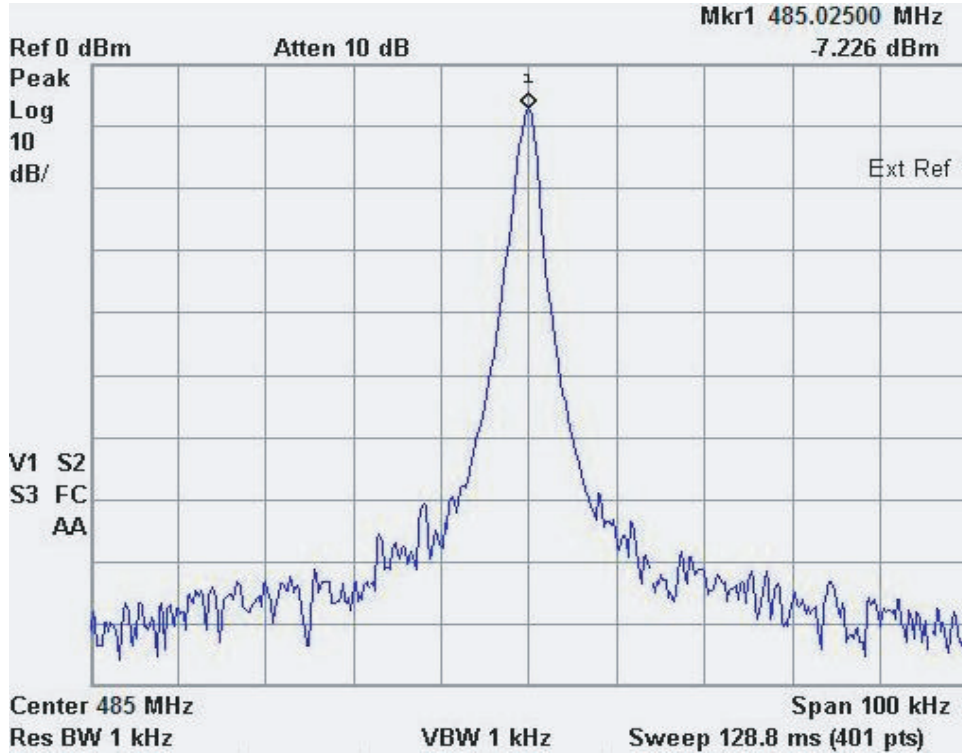

Probe point: TP299.

7.2.12 PP8 Higher Level Voltage Multiplier

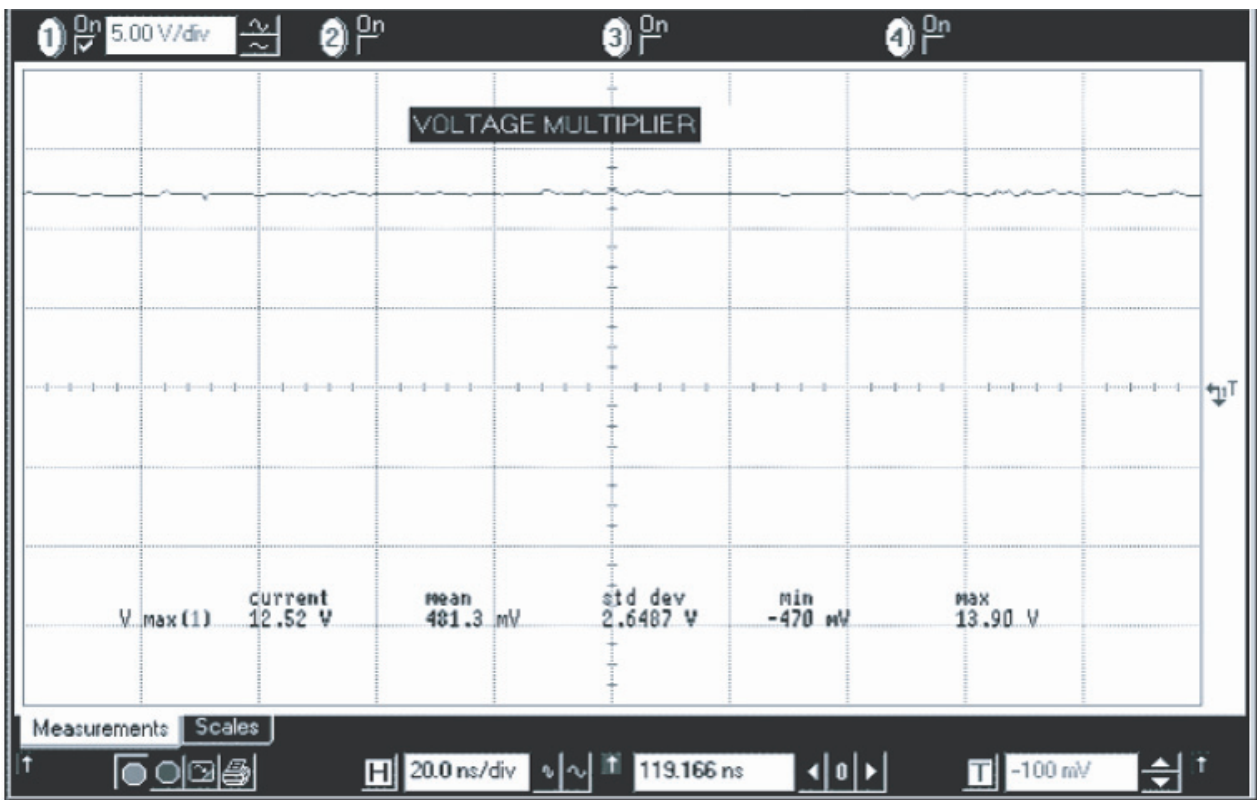

Probe point: C210 (located under shield).

7.2.13 PP9 Superfilter Output

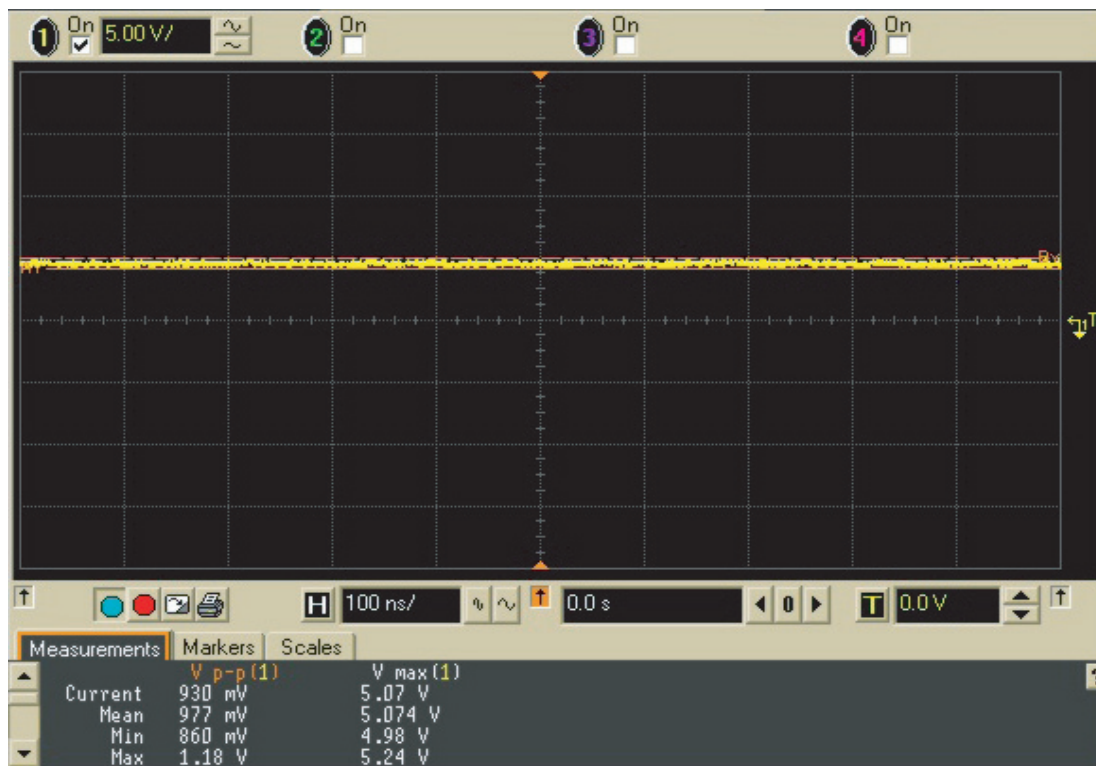

Probe point: SF_TP (located under shield).

7.2.14 PP11 Prescalar Input to FracN Synthesizer

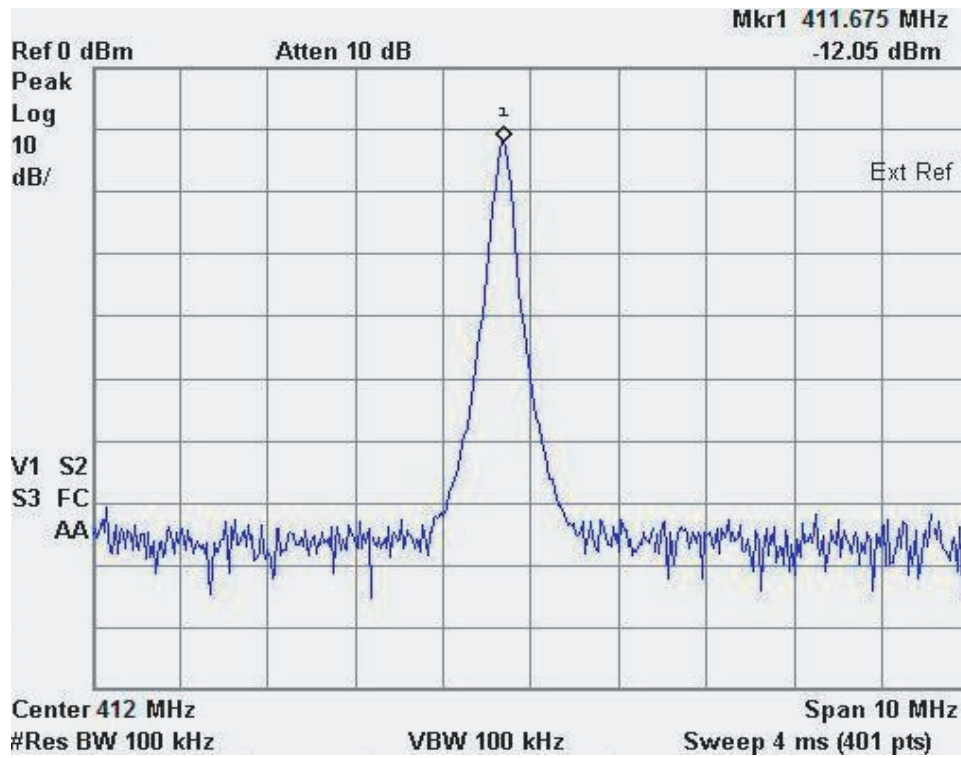

Probe point: TP23 (located under shield).

7.2.15 PP12 Reference Crystal Output

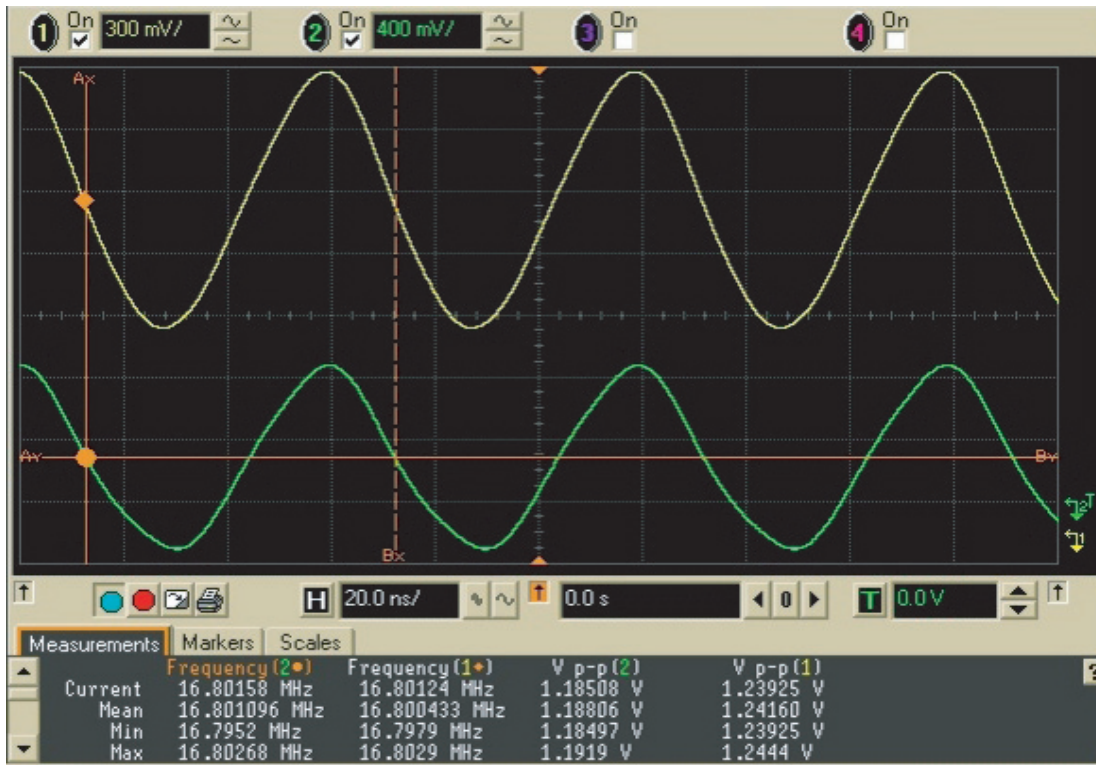

Probe point: R729 (16_8_filtered)
C726 (16_8MHZ).

7.2.16 TP13 Mod In

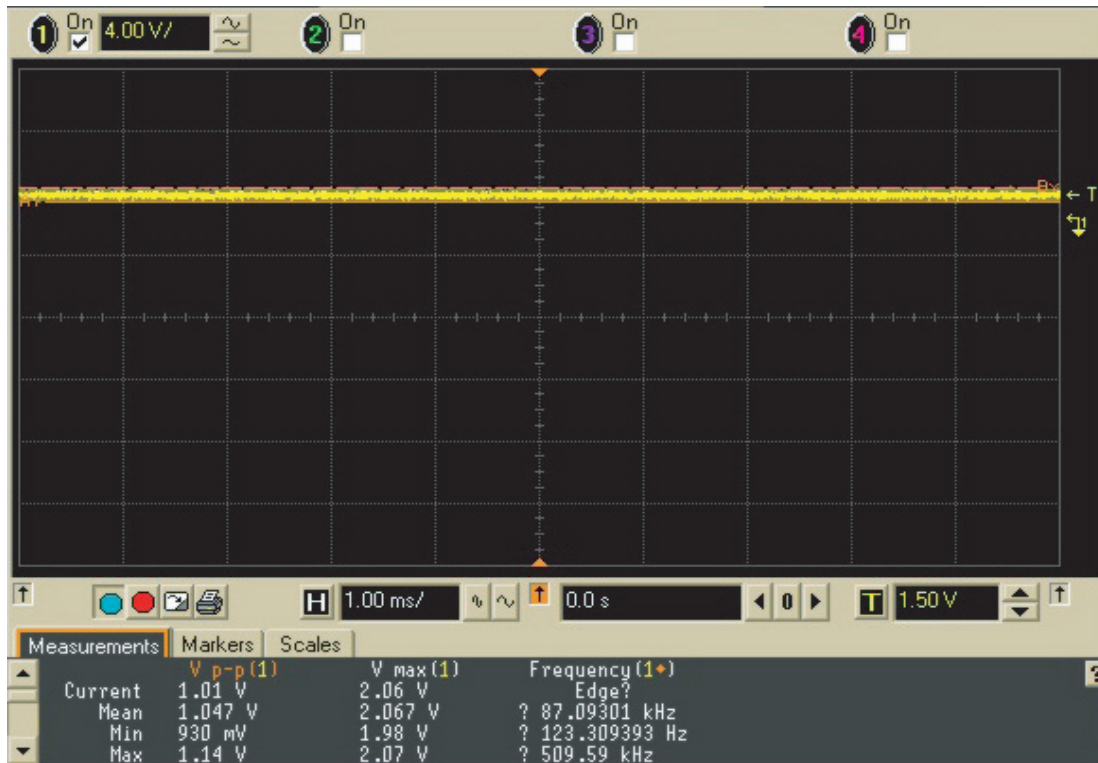

Test point: TP36.

7.2.17 TP14 1st LO Control Voltage

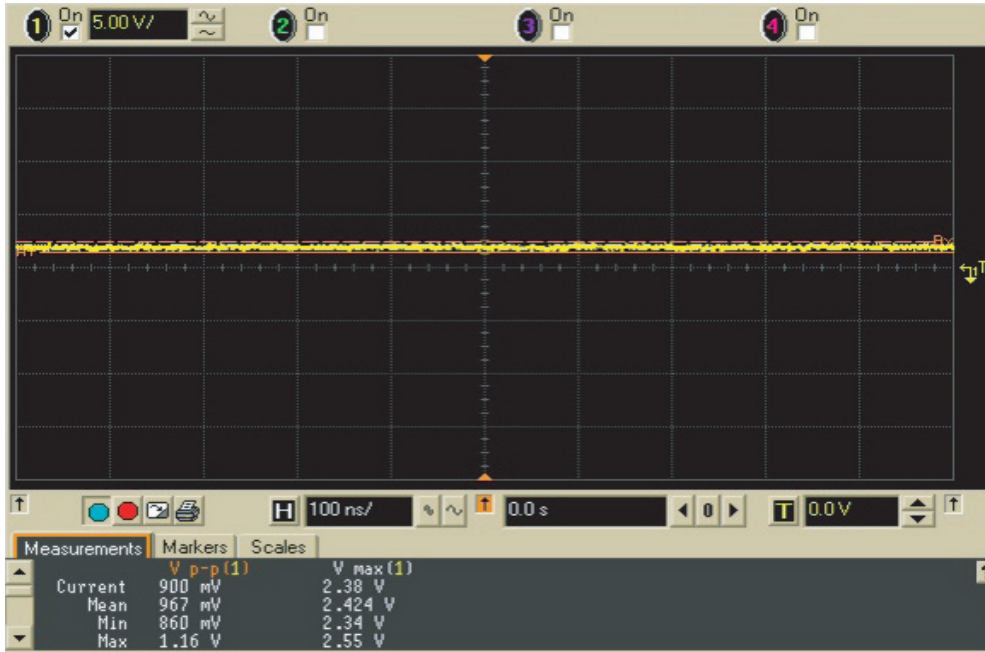

Test point VC_TP

7.2.18 PP15 VCO Output

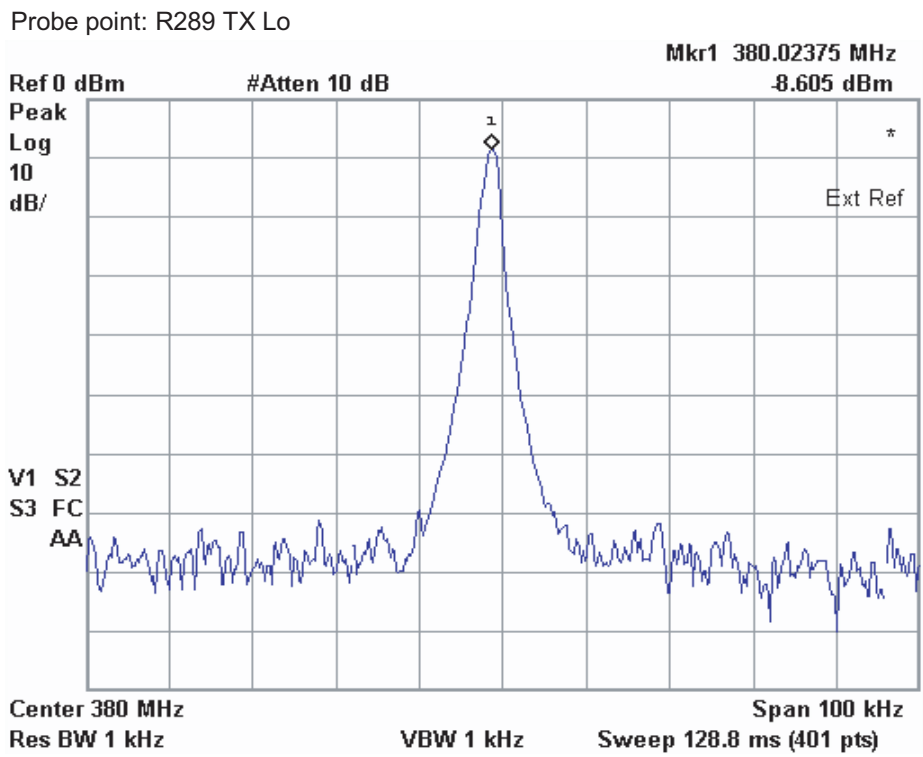
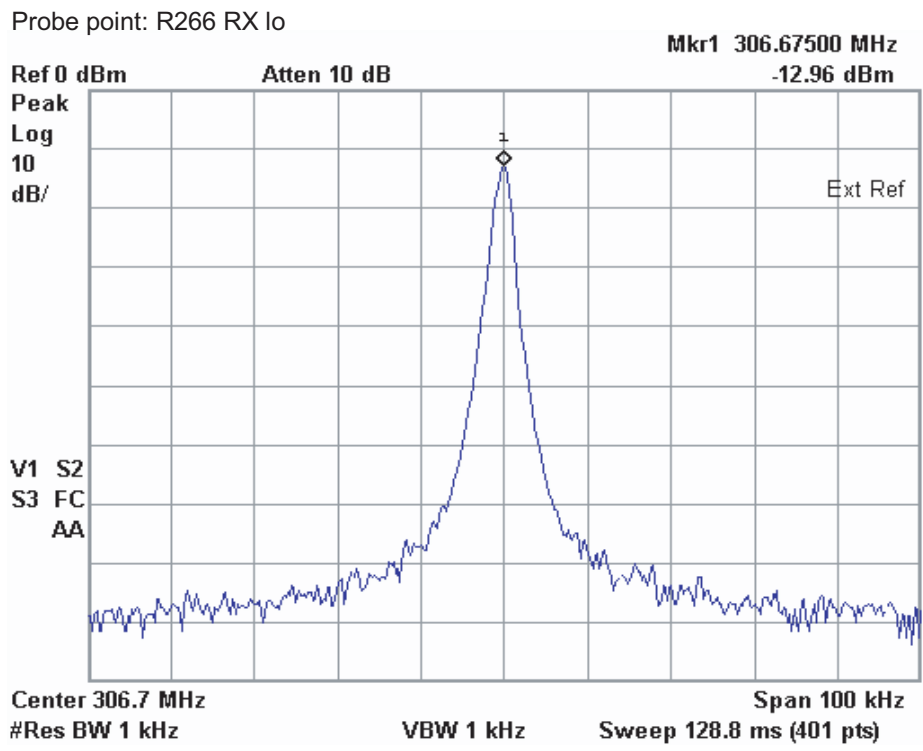

Probe point: Prescalar (TP23)

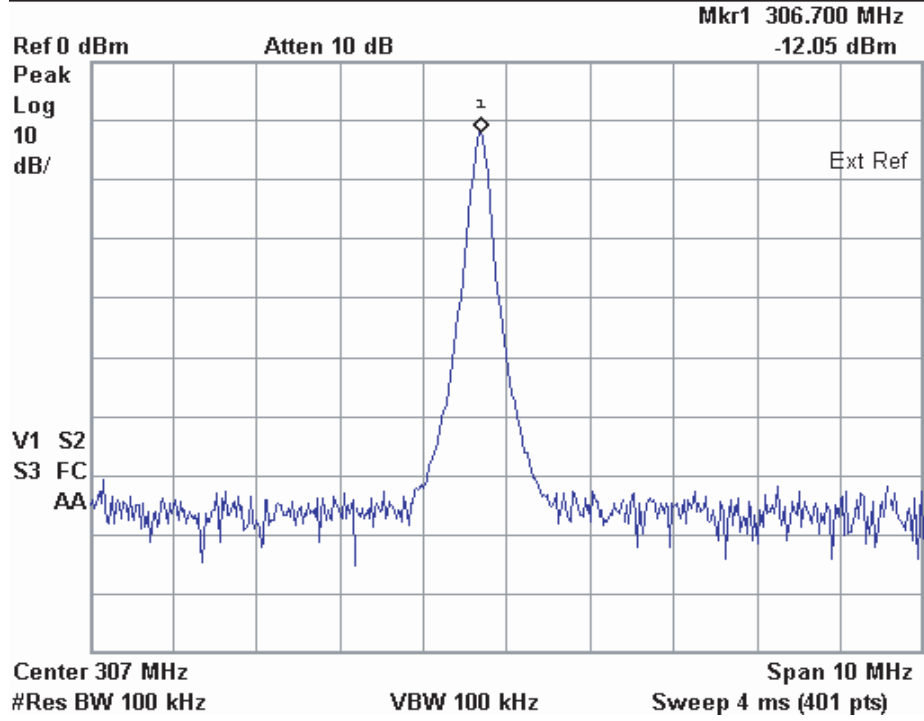

- Probe point: TP298 for LO Output
- TP299 for TX Output
- TP23 for Preselector Output (located under shield).
- Probe point: C261 (located under shield).

7.2.19 PP17 Frequency Out (19.2 MHz)



Probe point: 16out (Test Point).

7.2.20 PP18 RX RF Input at Antenna Switch

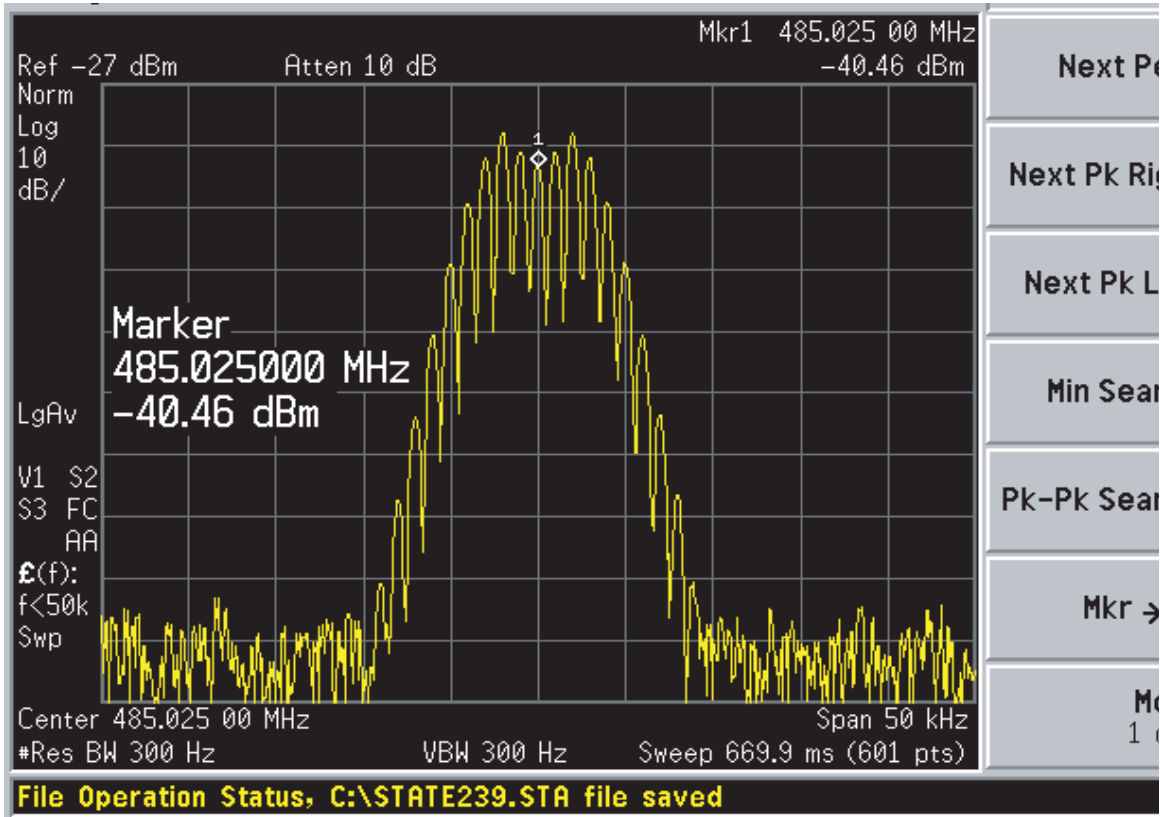

Probe point: C1.

Typical RX signal with 1 kHz modulation. Display shows modulation components of carrier.

7.2.21 PP19 Antenna Switch Bias

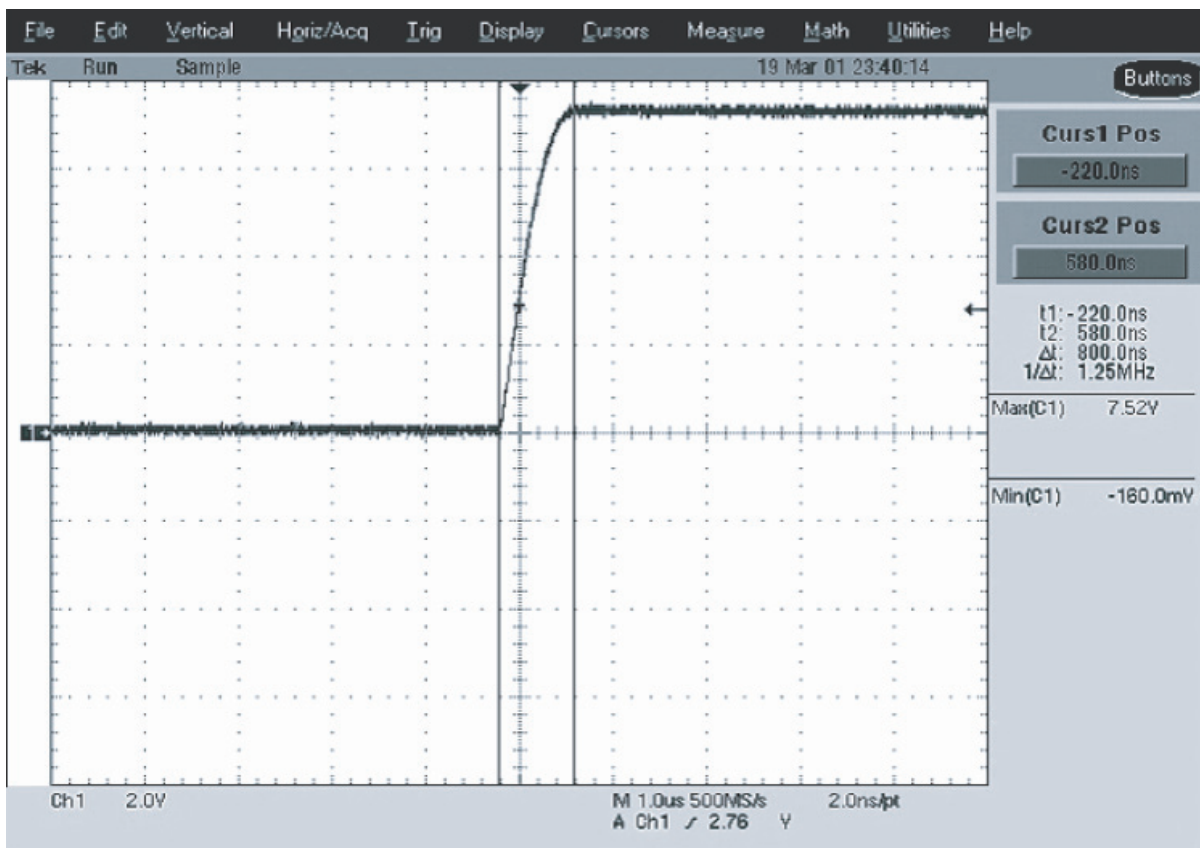

Probe point: U103, pin 1.

Display shows transition between RX mode (low) and TX mode (high).

7.2.22 PP20 Preselector Tuning Voltage

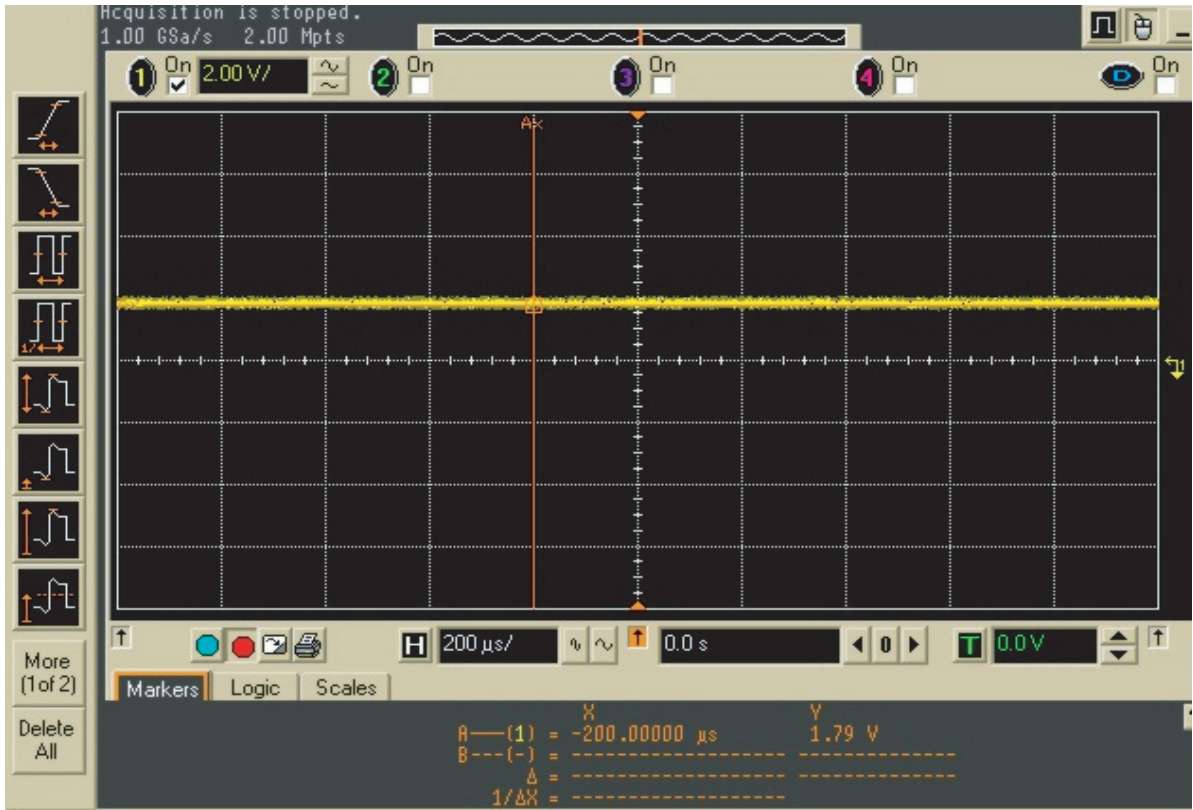

Probe point: C15 and C46.

This is a typical value when tuned to receive at 136.075MHz.

7.2.23 PP22 Analog 5V

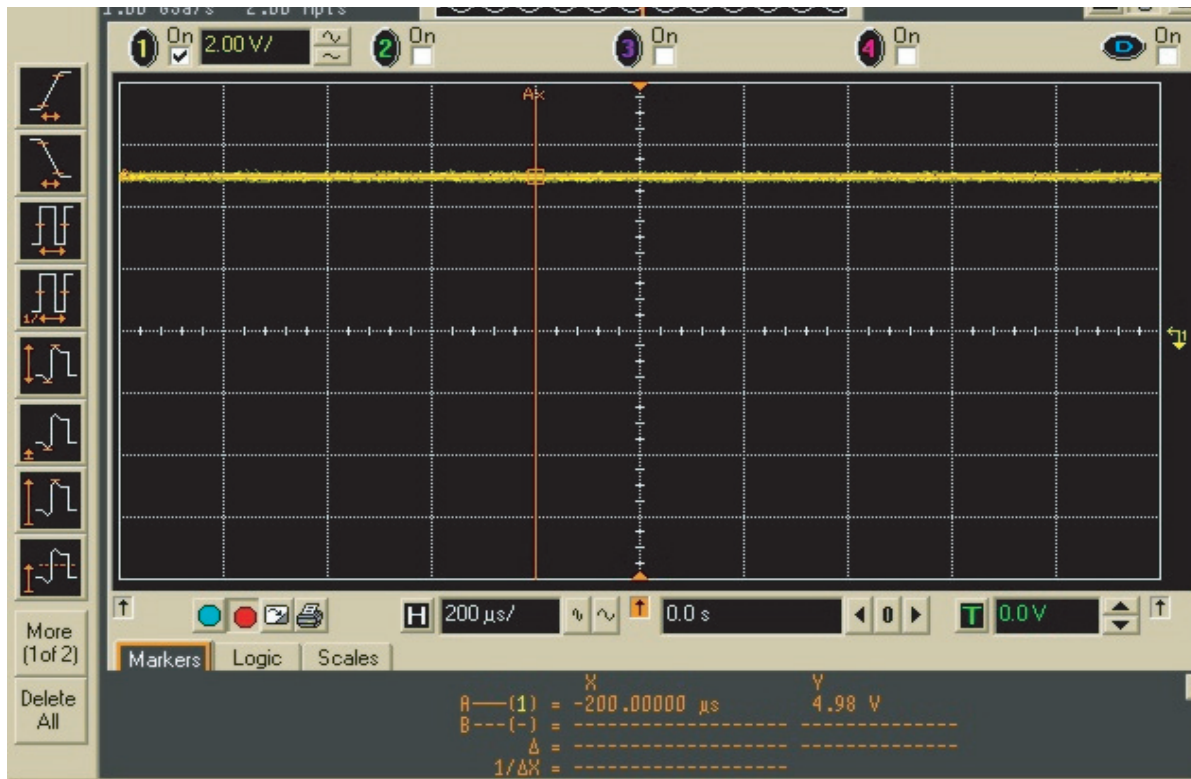

Probe point: U500, pin 5.

7.2.24 PP23 Preselector 1 Output

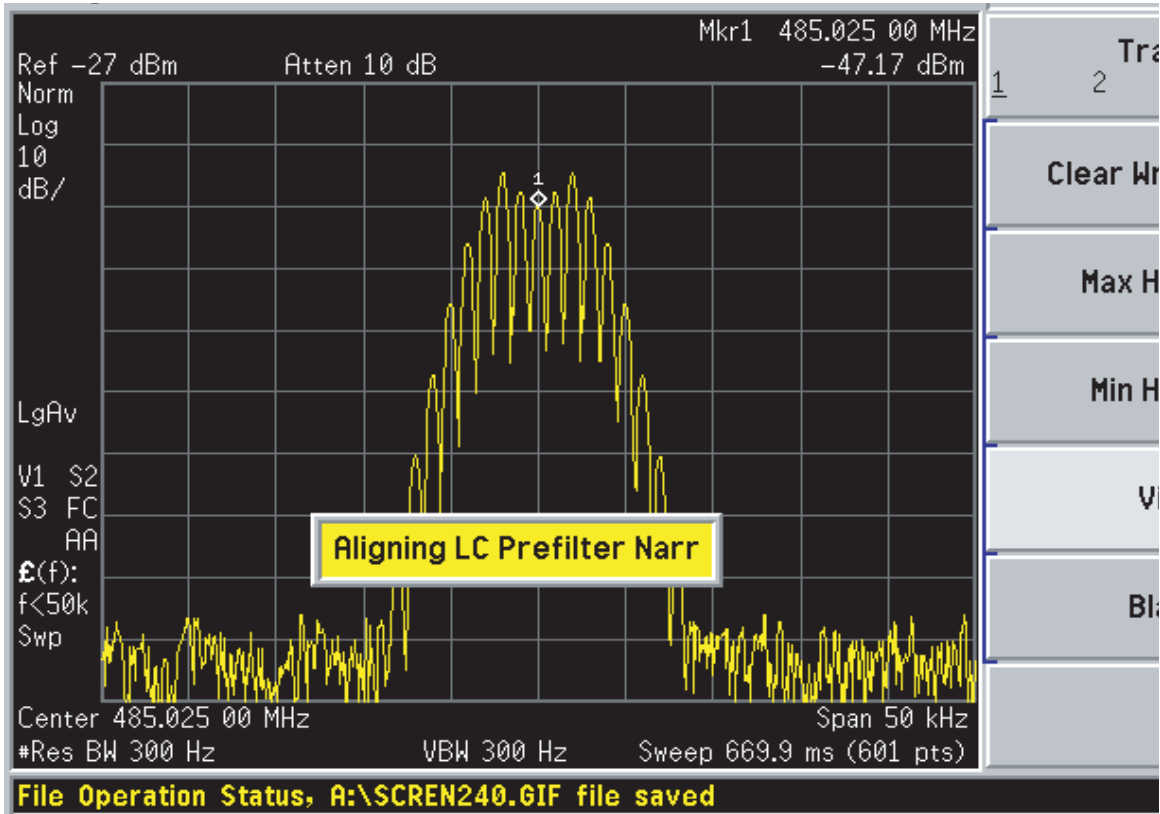

Probe point: C1.

Typical RX signal with 1 kHz modulation. Display shows modulation components of carrier.

7.2.25 PP24 Low-Noise Amplifier Output

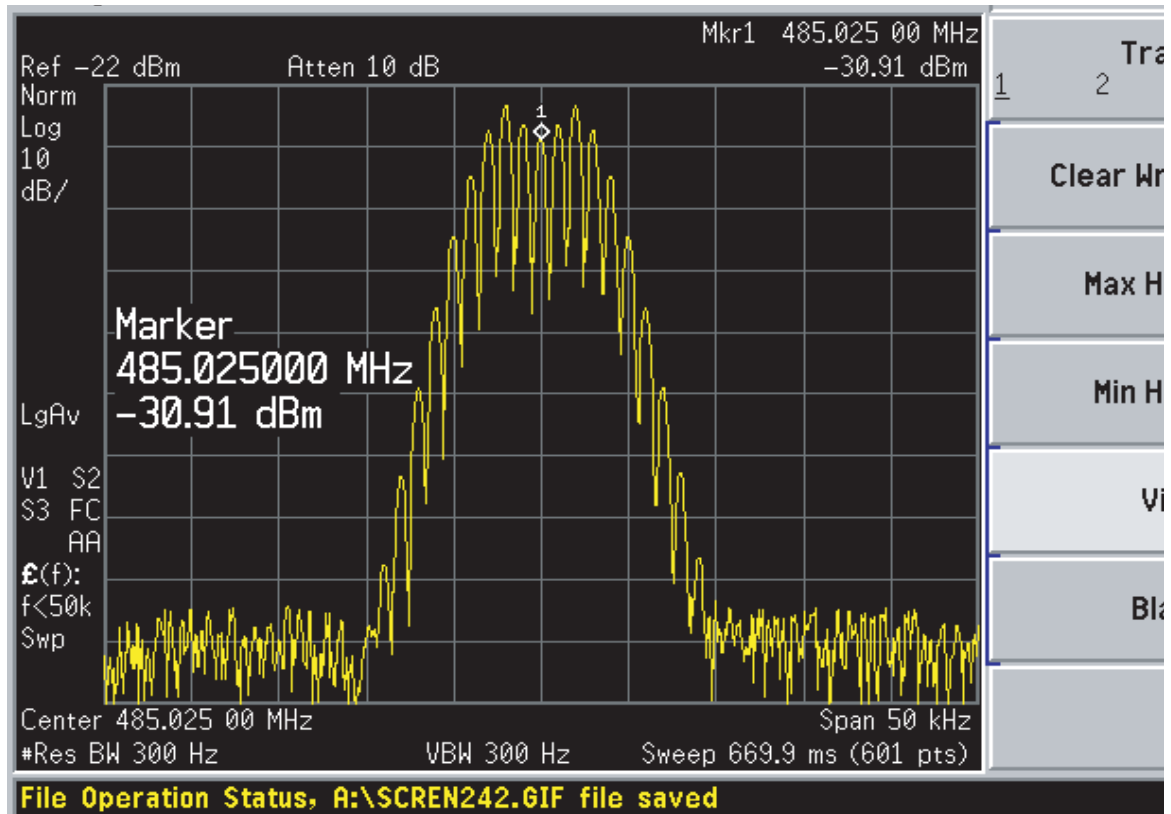

Probe point: C35.

Typical RX signal with 1 kHz modulation. Display shows modulation components of carrier.

7.2.26 PP25 Preselector 2 Output

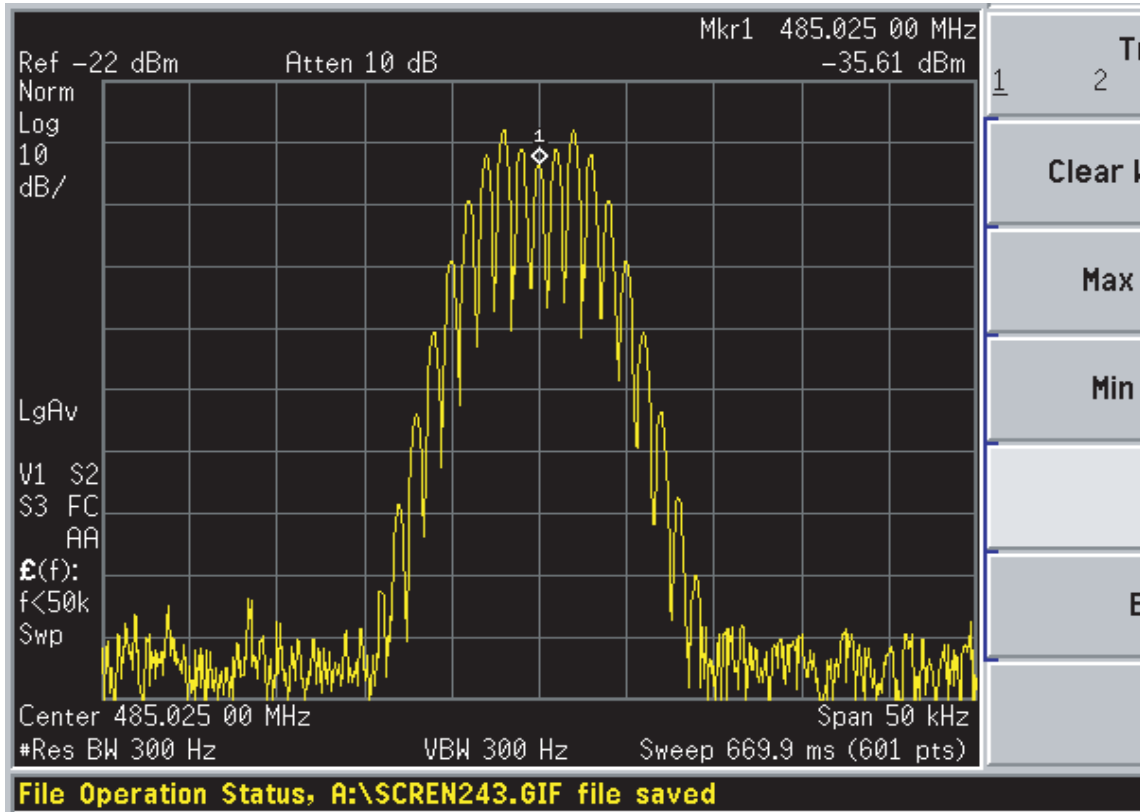

Probe point: C47.

Typical RX signal with 1 kHz modulation. Display shows modulation components of carrier.

7.2.27 PP26 Mixer Out (IF)

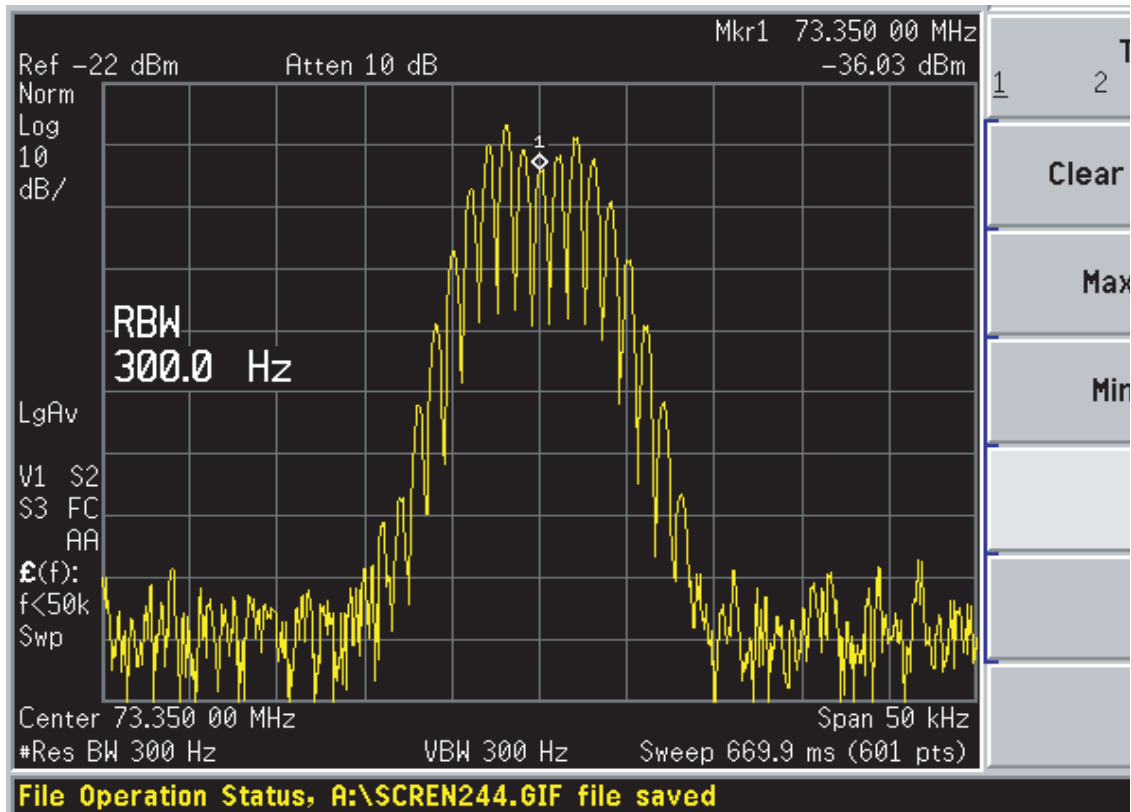

Probe point: C68.

Typical RX signal with 1 kHz modulation. Display shows modulation components of carrier.

7.2.28 PP27 Crystal Filter Out

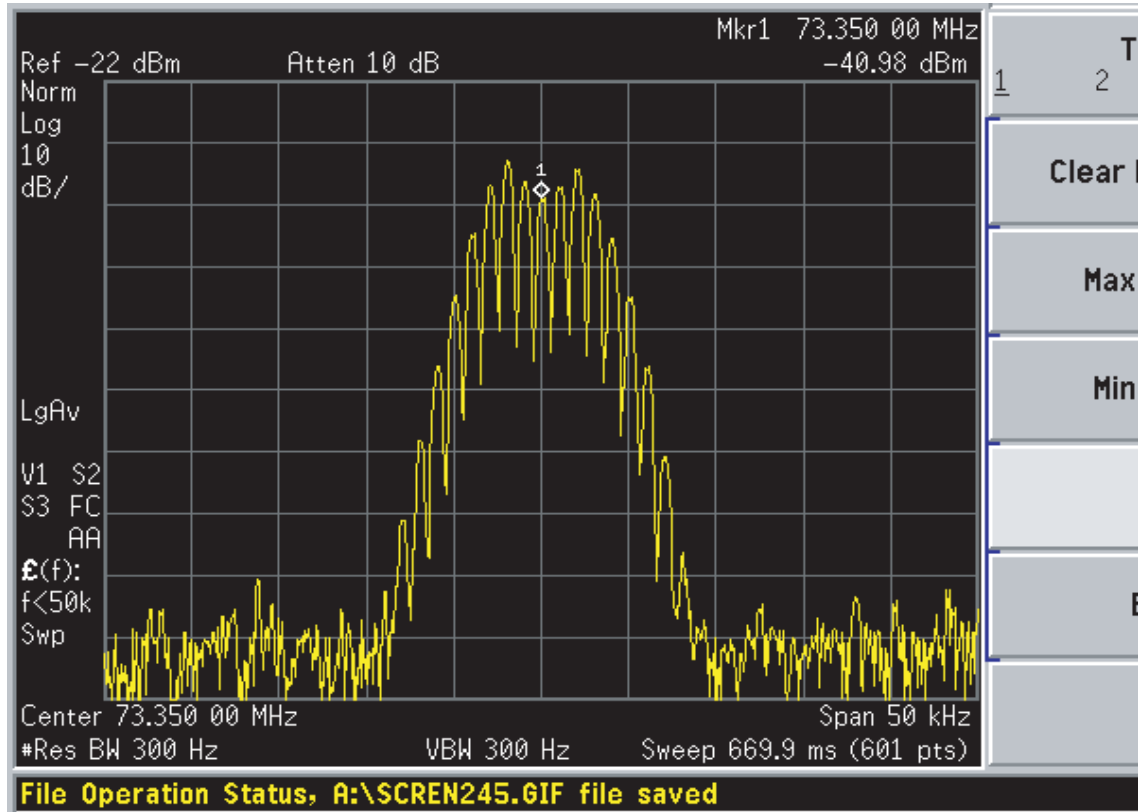

Probe point: L56.

7.2.29 PP28 Abacus Analog 3V

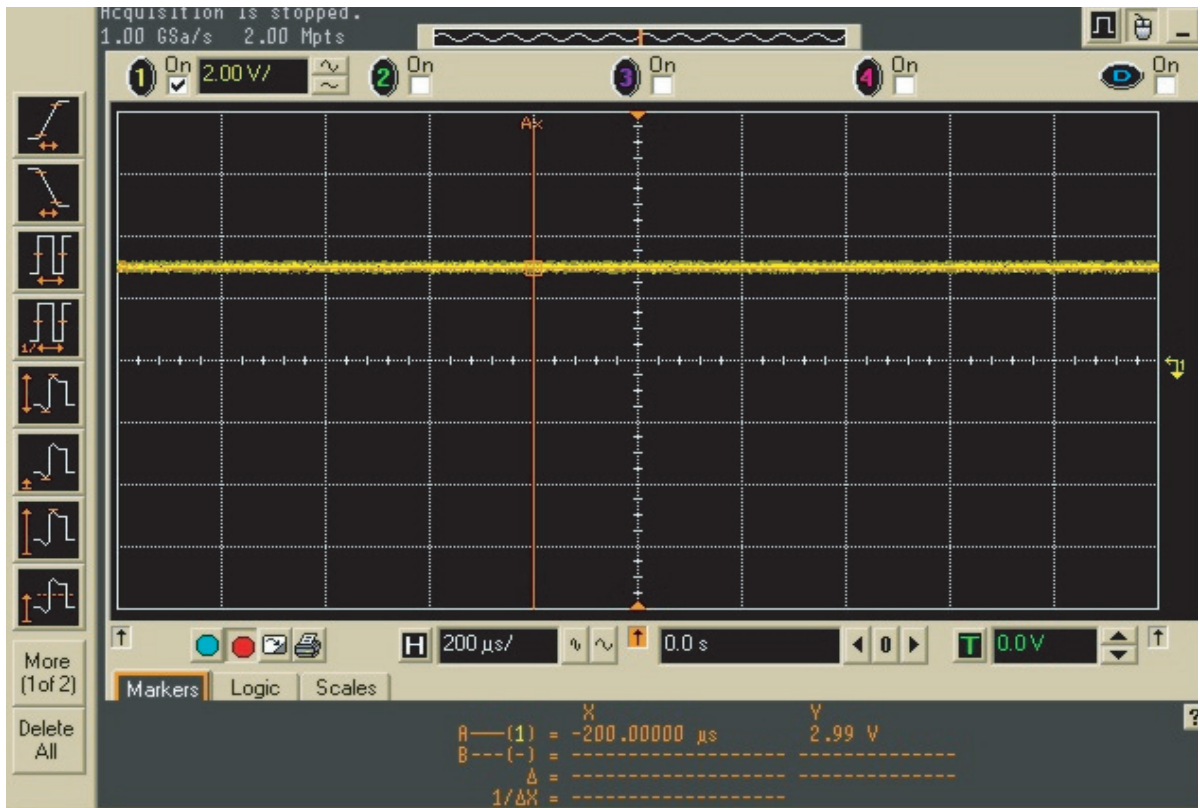

Probe point: U501, pin 5.

7.2.30 PP29 2nd LO Control Voltage

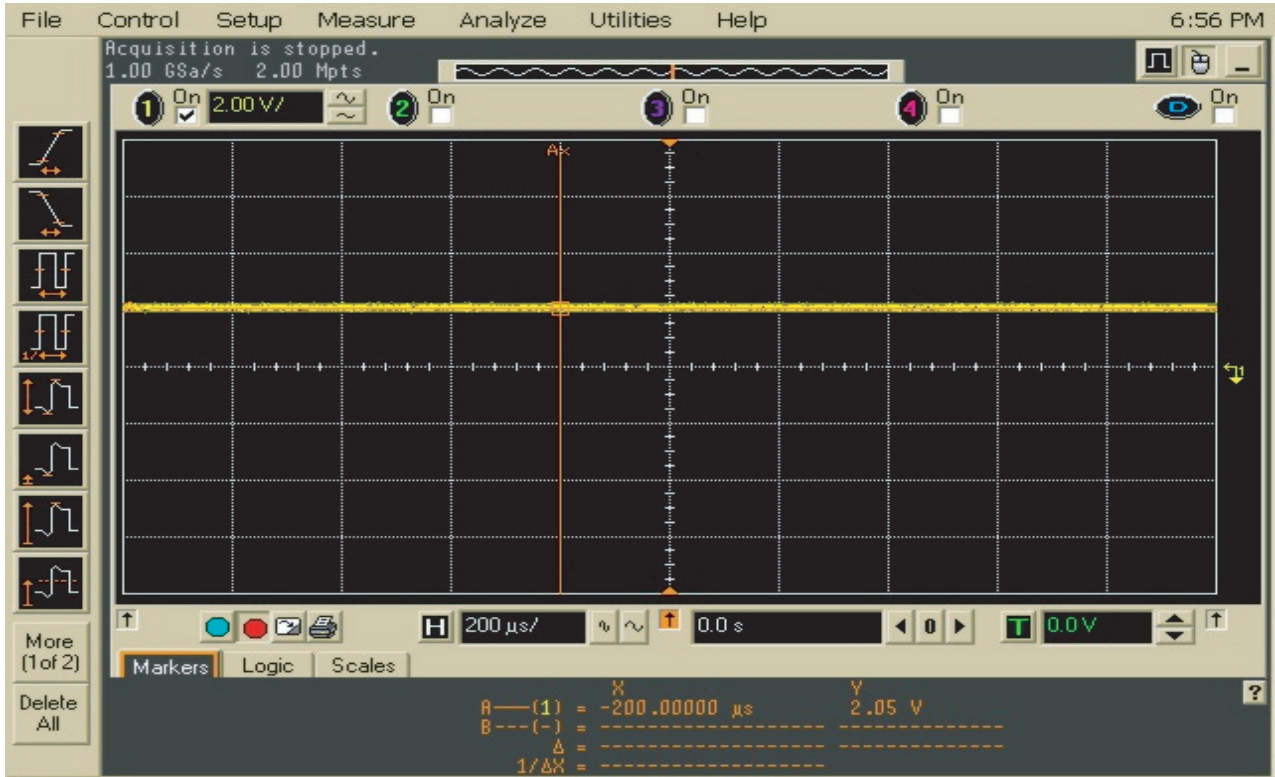

Probe point: U401, pin 38 (located under shield).

7.2.31 PP30 2nd LO VCO Buffer Output

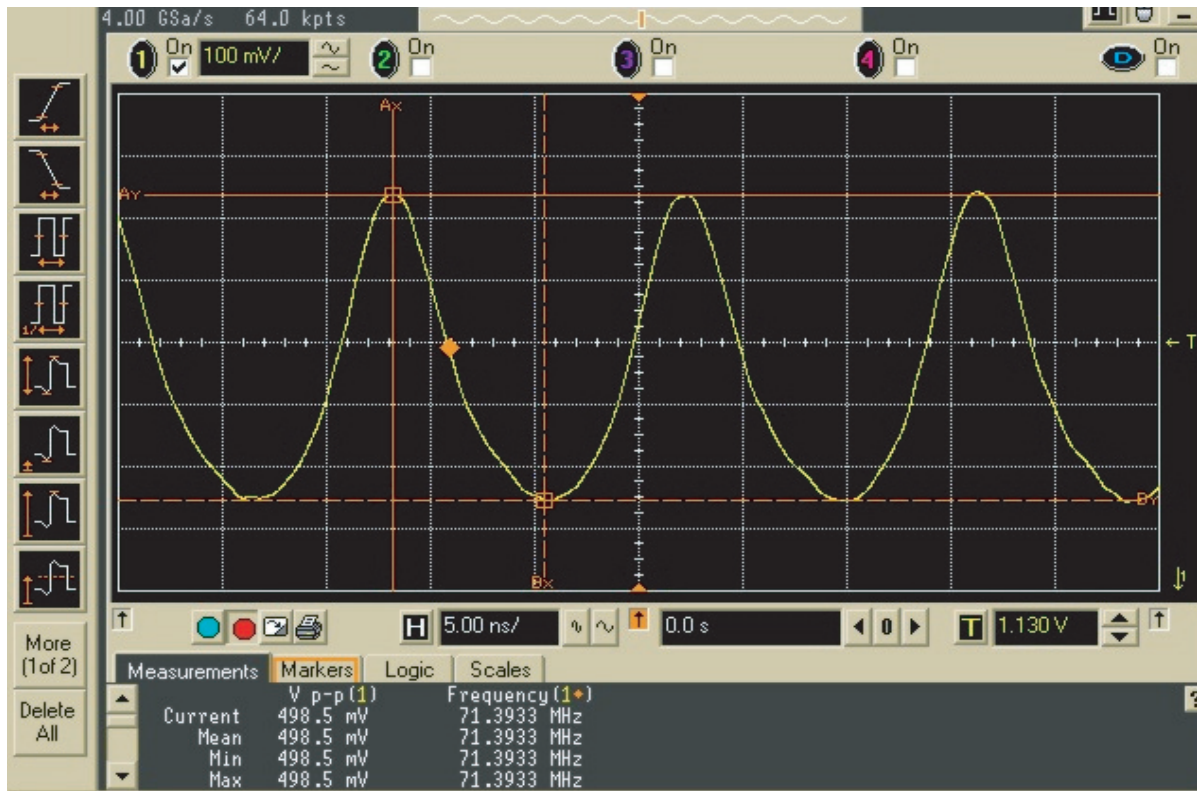

Probe point: C433.

7.2.32 PP31 Analog 5V DC

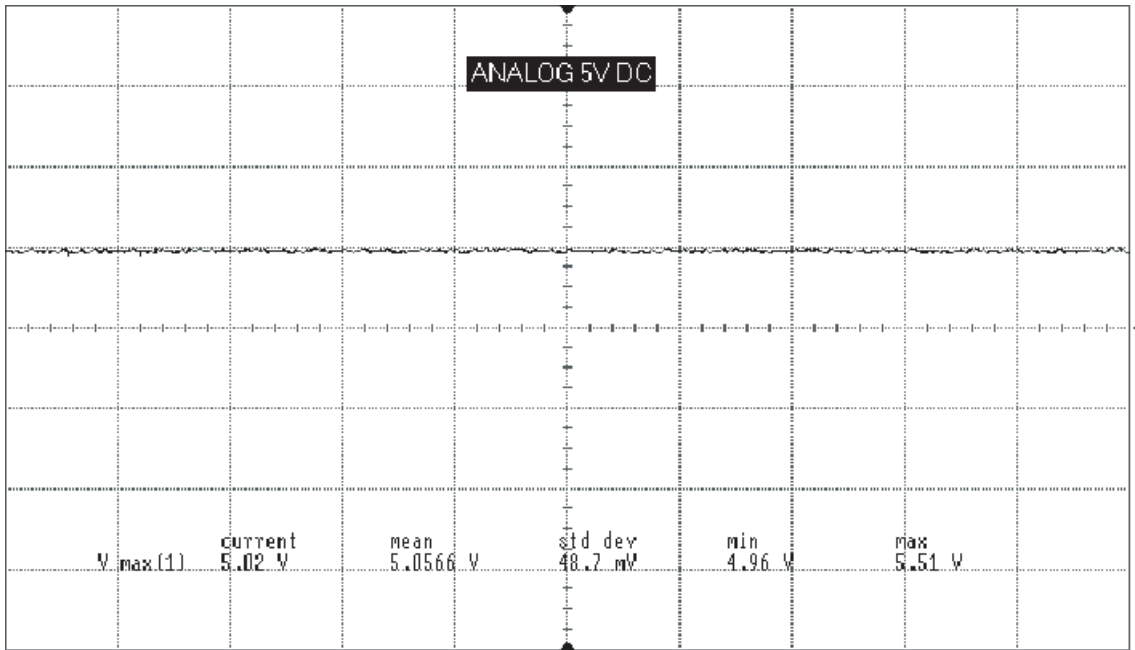

Probe point: U500, pin 5.

7.2.33 PP32 Abacus Digital 3V

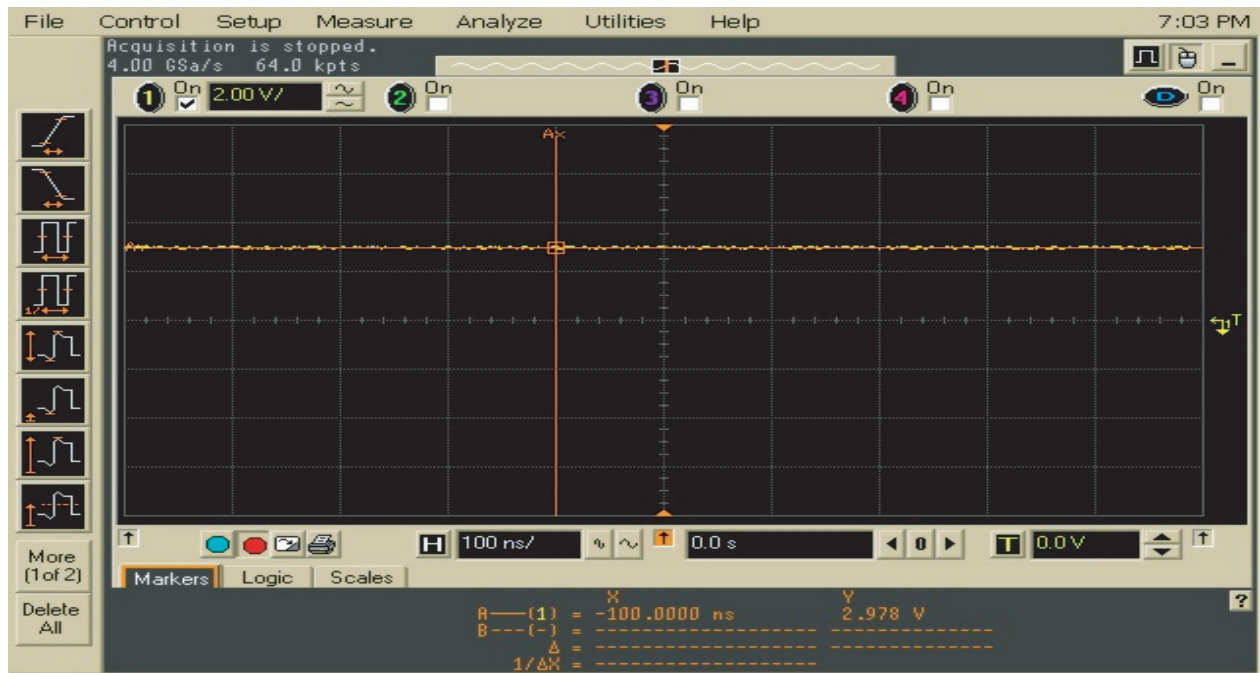

Probe point: U502, pin 5.

7.2.34 TX Audio 1 kHz Tone

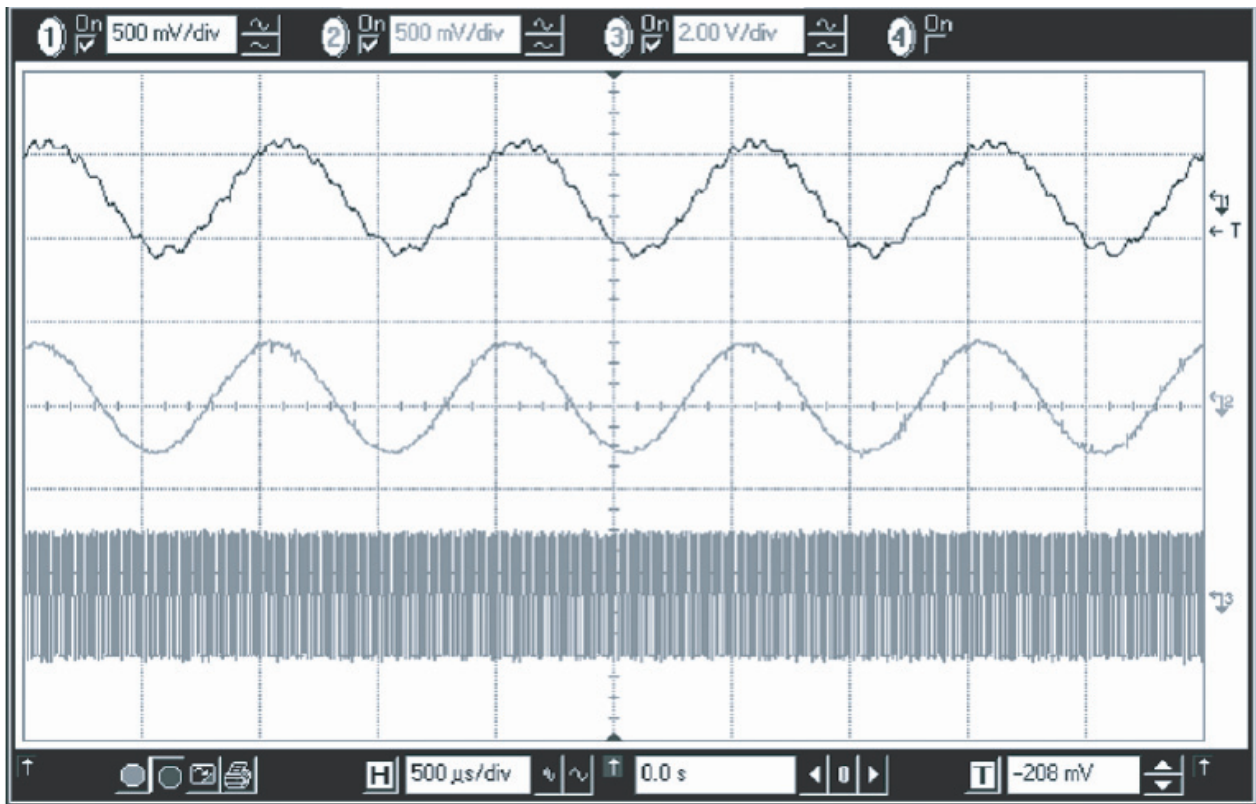

Trace 1: TP23 Mod In (640 mVp-p 1 kHz tone 1.5 Vdc)

Trace 2: U201, pin 1 (620 mVp-p 1 kHz tone)

Trace 3: FL200, pin 8 (1.2 MHz square wave 0 to 3 V)

Note: Transmit audio 1 kHz tone, which provides 3 kHz deviation.

7.2.35 16.8 MHz Buffer Input and Output

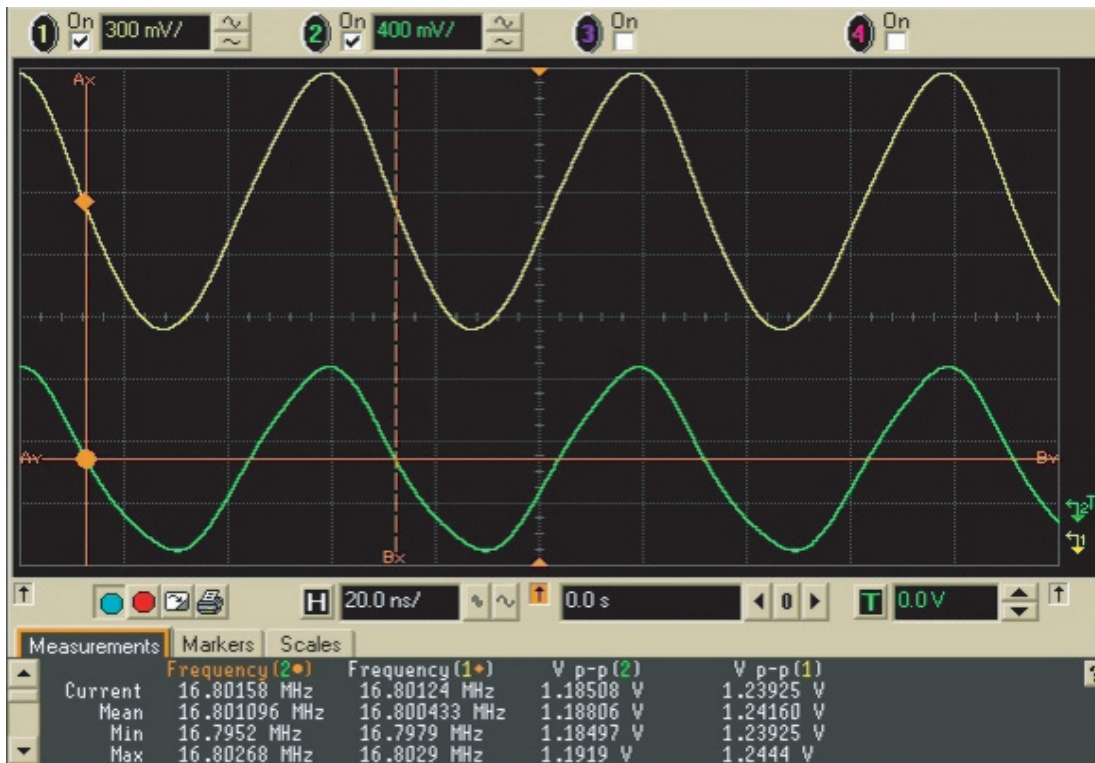

Trace 1: Buffer input at R729.
Trace 2: Buffer output at C726.

7.2.36 32.768 kHz Clock Outputs



Trace 1: Output at C743.

Trace 2: Output at U712, pin 4.

7.2.37 SPI B Data

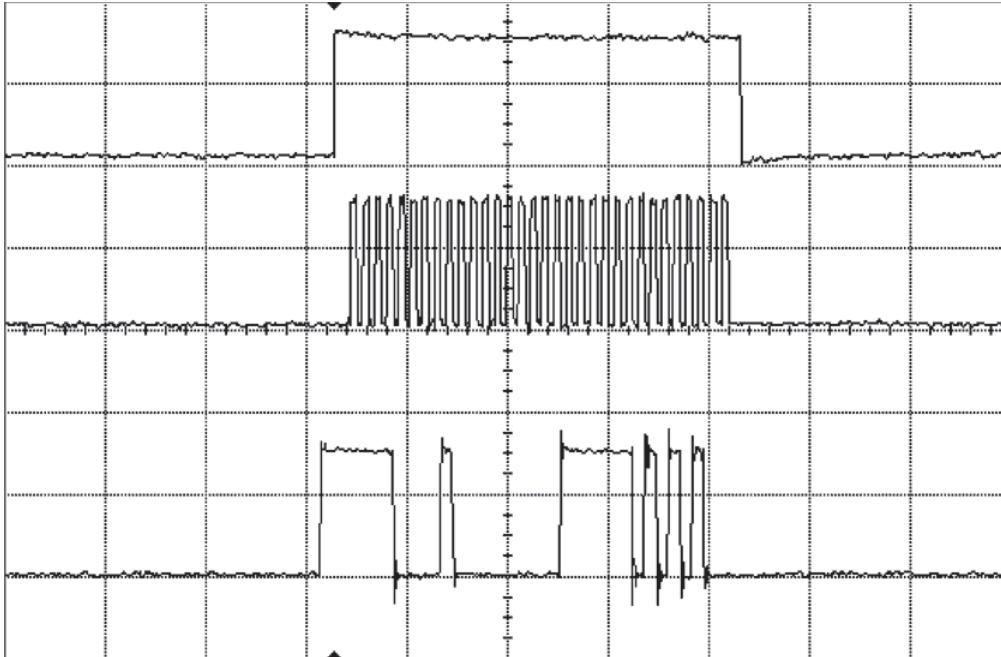

Acquisition	Sampling mode real time Configuration 4GSa/s Memory depth automatic Memory depth 1004pts Sampling rate automatic Sampling rate 50.0 MSa/s Averaging off 9-bit B'W Filter off Interpolation on
Channel 1	Scale 1.99 V/div Offset -4.21 V Coupling DC Impedance 1M Ohm Attenuation 10.00 : 1 Atten units ratio Skew 0.0 s Ext adapter None Ext coupler None Ext gain 1.00E+00 Ext offset 0.0E+00
Channel 2	Scale 2.00 V/div Offset -260 mV Coupling DC Impedance 1M Ohm Attenuation 10.00 : 1 Atten units ratio Skew 0.0 s Ext adapter None Ext coupler None Ext gain 1.00E+00 Ext offset 0.0E+00
Channel 3	Scale 2.00 V/div Offset 5.76 V Coupling DC Impedance 1M Ohm Attenuation 10.00 : 1 Atten units ratio Skew 0.0 s Ext adapter None Ext coupler None Ext gain 1.00E+00 Ext offset 0.0E+00
Time base	Scale 2.00 μ s/div Position 3.454546 μ s Reference center
Trigger	Mode edge Sweep auto Hysteresis normal Holdoff time 60 ns Coupling DC Source channel 1 Trigger level 810 mV Slope rising

Trace 1: MAKO chip enable, R767 (not active high)

Trace 2: SPI data clock, C619

Trace 3: SPI data to MAKO, C617.

7.2.38 RX Serial Audio Port (SAP)

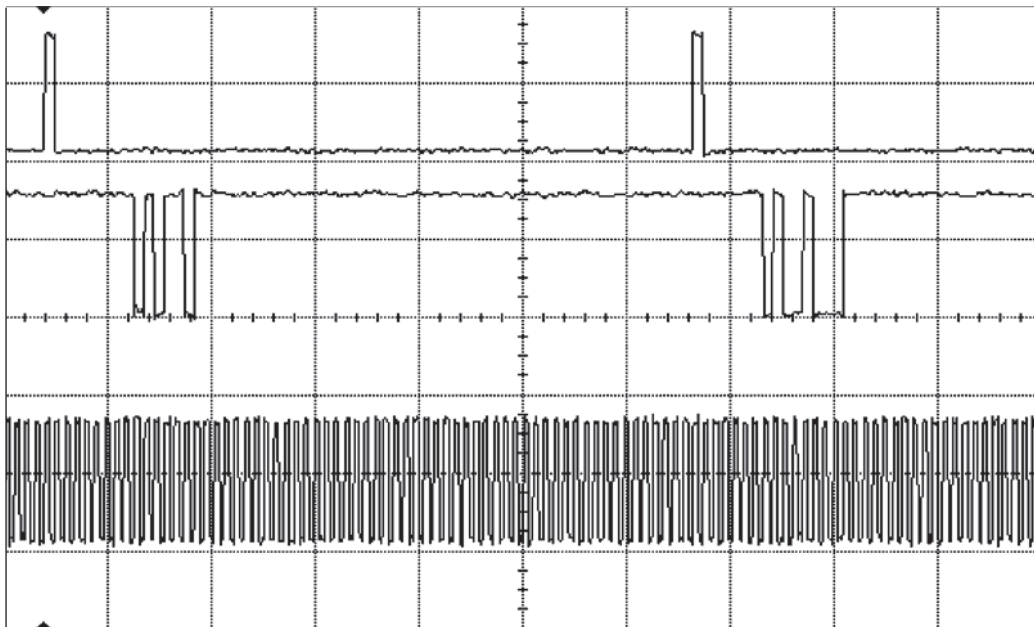

Acquisition	Sampling mode real time Configuration 4GSa/s Memory depth automatic Memory depth 1004pts Sampling rate automatic Sampling rate 5.00 MSa/s Averaging off 9-bit BW Filter off Interpolation on
Channel 1	Scale 1.99 V/div Offset -4.21 V Coupling DC Impedance 1M Ohm Attenuation 10.00 : 1 Atten units ratio Skew 0.0 s Ext adapter None Ext coupler None Ext gain 1.00E+00 Ext offset 0.0E+00
Channel 2	Scale 2.00 V/div Offset -210 mV Coupling DC Impedance 1M Ohm Attenuation 10.00 : 1 Atten units ratio Skew 0.0 s Ext adapter None Ext coupler None Ext gain 1.00E+00 Ext offset 0.0E+00
Channel 3	Scale 2.00 V/div Offset 5.55 V Coupling DC Impedance 1M Ohm Attenuation 10.00 : 1 Atten units ratio Skew 0.0 s Ext adapter None Ext coupler None Ext gain 1.00E+00 Ext offset 0.0E+00
Time base	Scale 20.0 μ s/div Position 92.181816 μ s Reference center
Trigger	Mode edge Sweep auto Hysteresis normal Holdoff time 60 ns Coupling DC Source channel 1 Trigger level 810 mV Slope rising

Note: TX is identical, except the data is probed at test point "TX".

Trace 1: 8 kHz frame sync (each word is 13 bits after falling edge of FSYNC)

Trace 2: SAP data at R626 (audio data from MAKO CODEC to Patriot DSP)

Note: Transmit is identical, except data acquired at R625

Trace 3: 512kHz bit clock at R616. (Codec_DCLK).

7.2.39 PP33 SPI Data

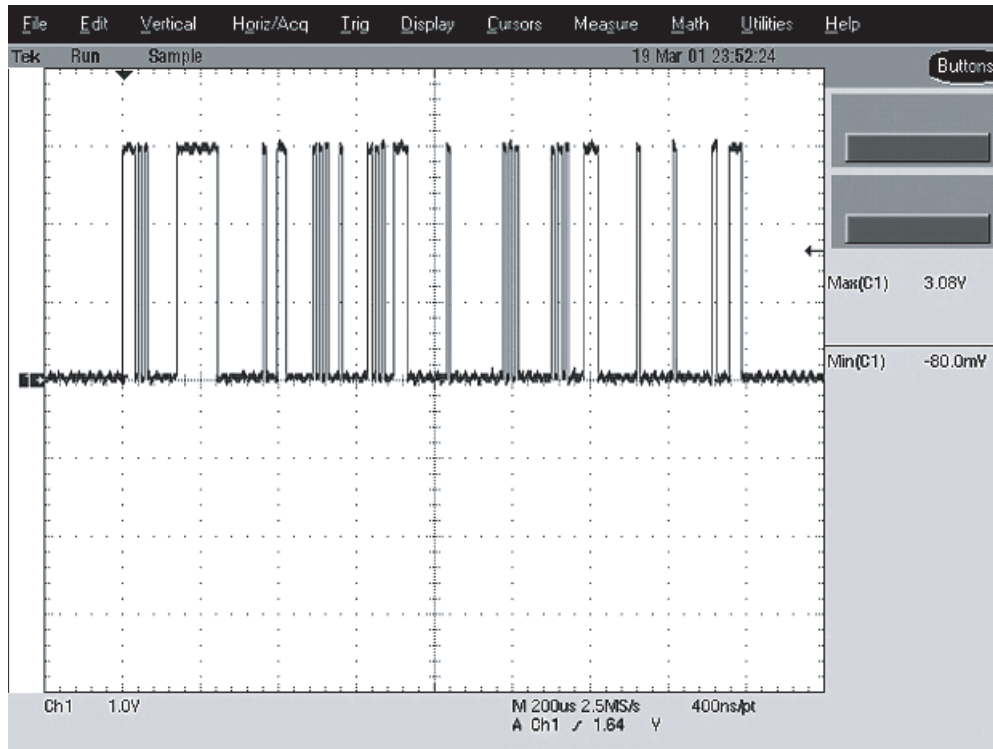

Probe Point: R802.

7.2.40 PP34 SPI CLK

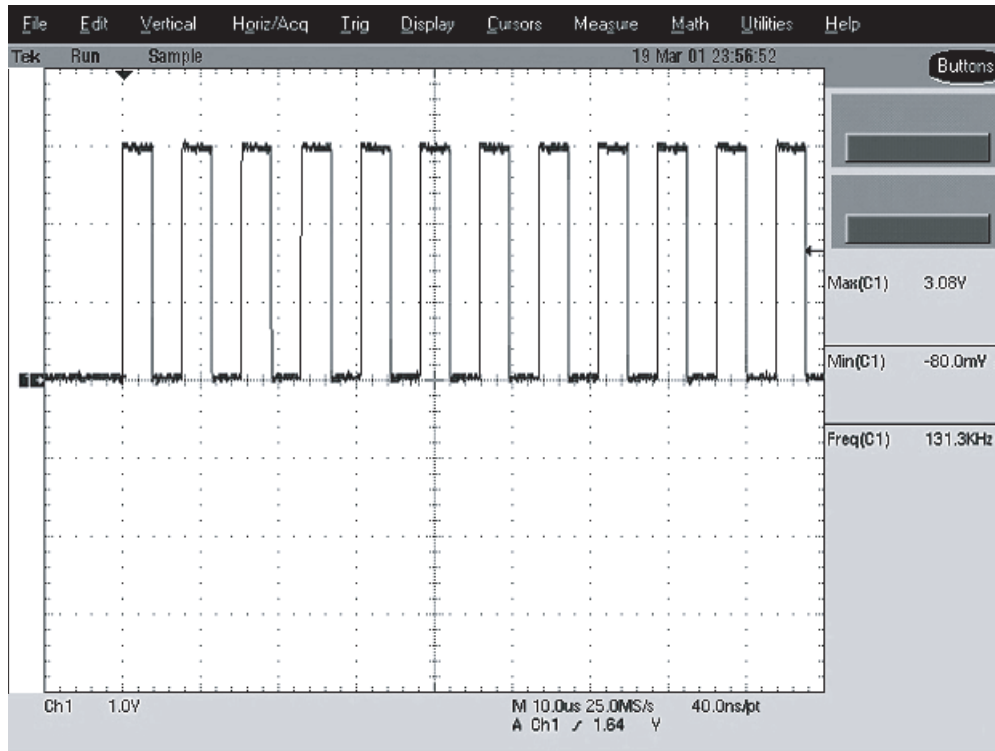

Probe Point: R803.

7.2.41 PP35 Universal Chip Select

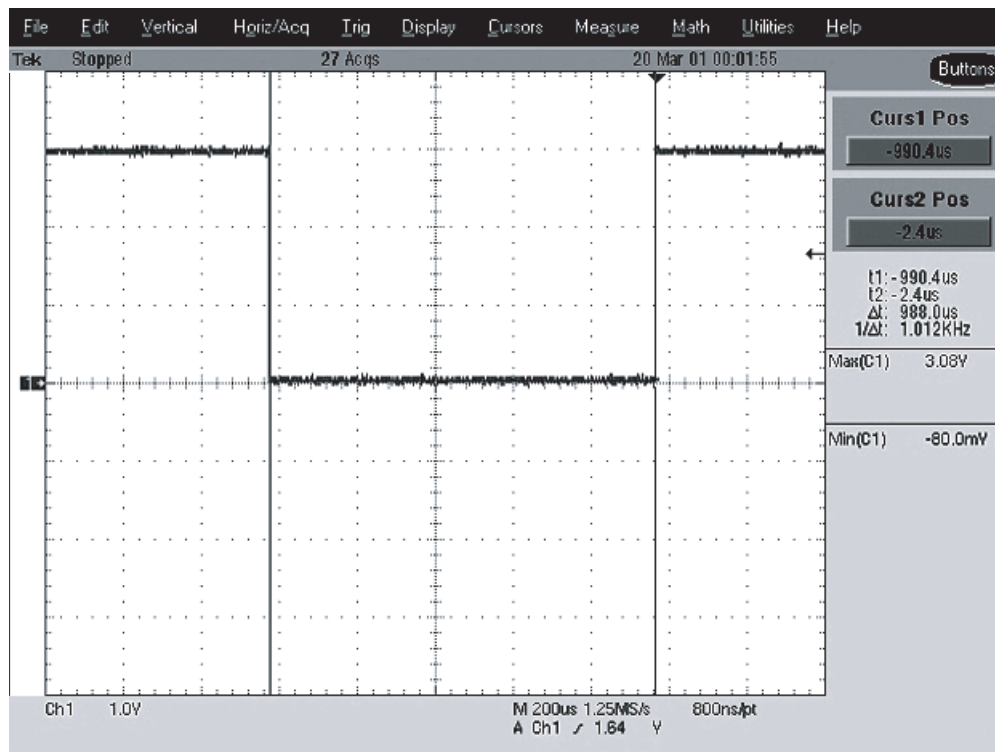

Probe Point: U102, pin 29 (located under shield).

7.2.42 PP36 Abacus Chip Select

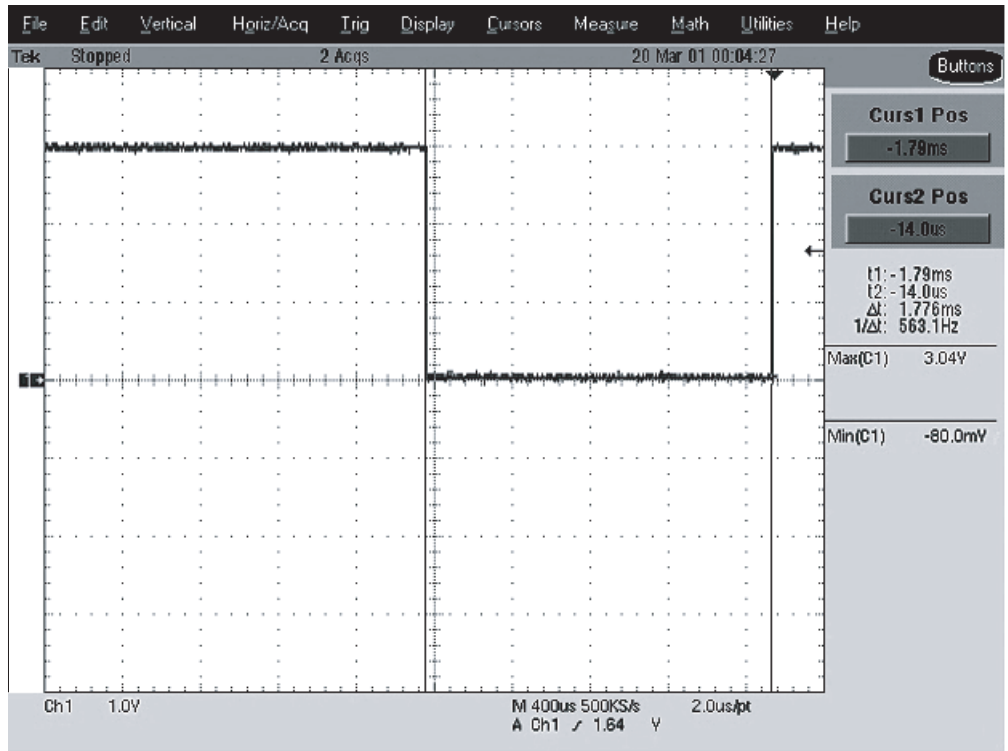

Probe Point: U401, pin 25 (located under shield).

7.2.43 TP37 RX SSI Data

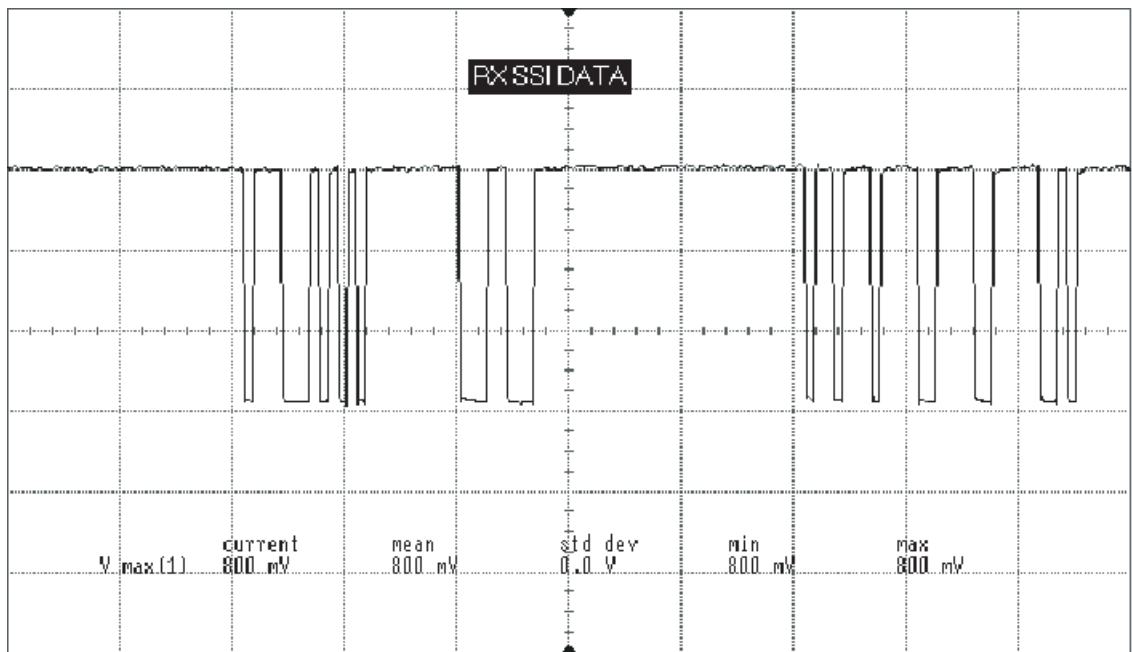

Test Point: SSI_D (Test Point).

7.2.44 TP38 RX SSI Clock

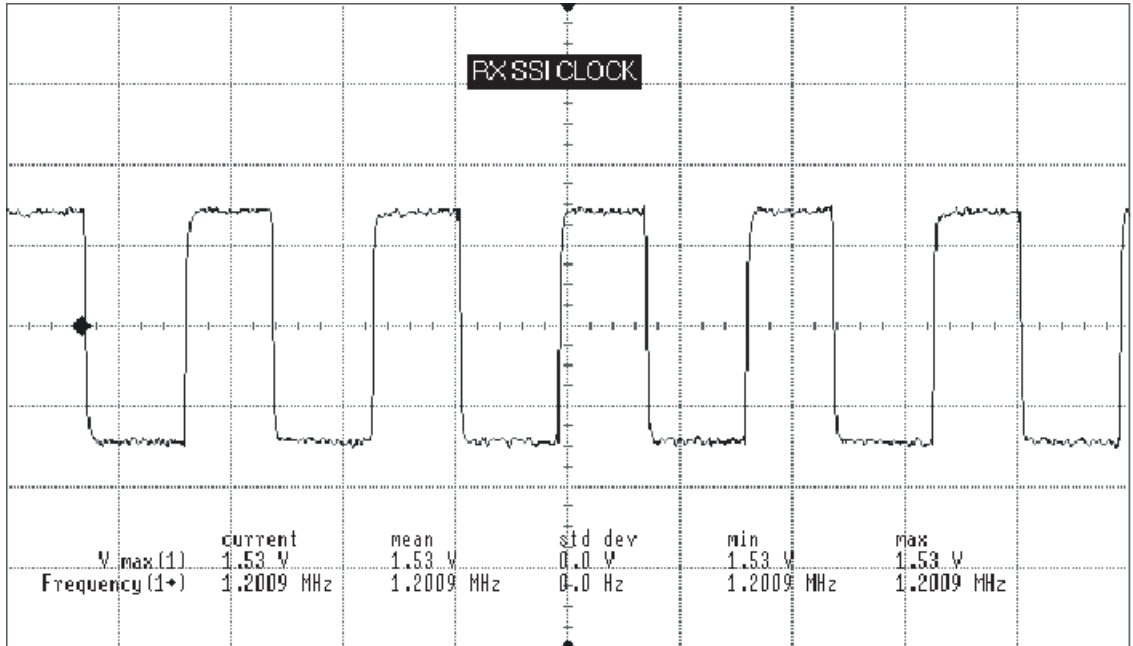

Test Point: SSI_CLK (Test Point).

7.2.45 TP39 RX SSI Frame Sync

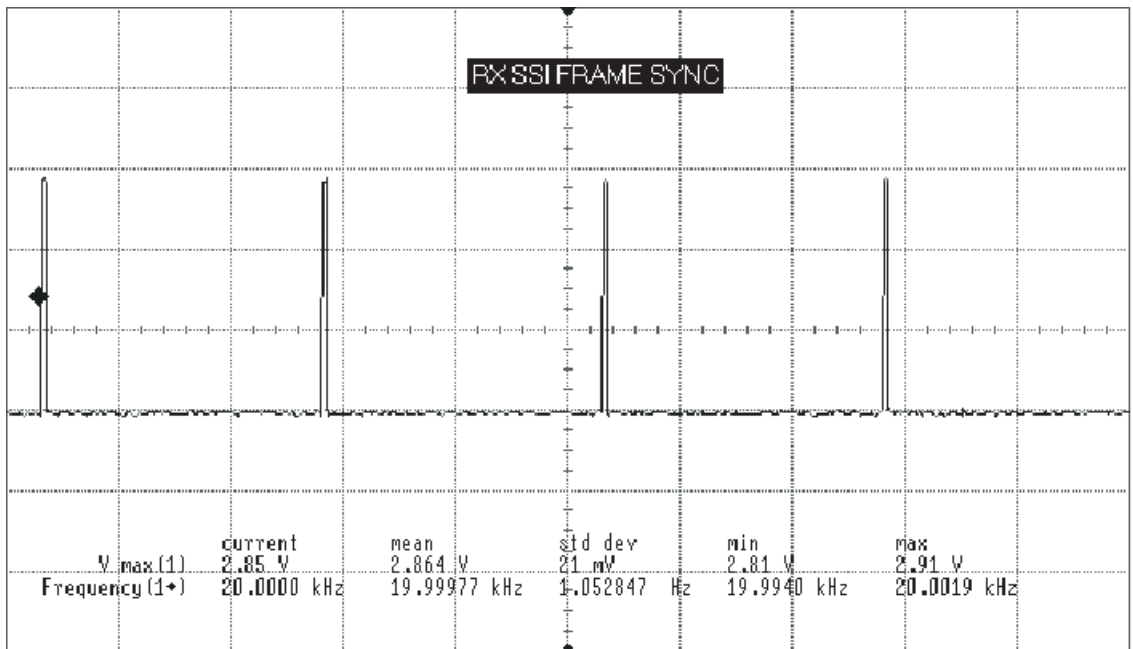

Test Point: SSI_FS (Test Point).

Test Point: TP401.

Notes

Chapter 7.3 UHF2 Troubleshooting Waveforms

7.3.1 Introduction

This chapter contains images of waveforms that might be useful in verifying operation of certain parts of the circuitry. These waveforms are for reference only; the actual data depicted will vary depending upon operating conditions. This manual is to be used in conjunction with the ASTRO XTS 2500/ XTS 2500I Digital Portable Radios Basic Service Manual (Motorola part number 6816984H01), which uses the pass/fail service approach to radio problems.

7.3.2 List of Waveforms

[Table 7.3-1](#) lists each waveform and the page on which the waveform can be found.

Table 7.3-1. List of Waveforms

Waveform	Page No.	Waveform	Page No.
Antenna Input	7.3-6	Low-Noise Amplifier Output	7.3-26
TX Signal at Harmonic Filter Input	7.3-7	Preselector 2 Output	7.3-27
Coupler RF Out	7.3-8	Mixer Out (IF)	7.3-28
TX Signal at PA	7.3-9	Crystal Filter Out	7.3-29
Coupler RF Feedback to PCIC	7.3-10	Abacus Analog 3V	7.3-30
PCIC Control Voltage	7.3-11	2nd LO Control Voltage	7.3-31
TX LO	7.3-12	2nd LO VCO Buffer Output	7.3-32
Higher Level Voltage Multiplier	7.3-13	Abacus Digital 3V	7.3-34
Superfilter Output	7.3-14	TX Audio 1 kHz Tone	7.3-35
Prescaler Input to FracN Synthesizer	7.3-15	16.8 MHz Buffer Input and Output	7.3-36
Reference Crystal Output	7.3-16	32.768 kHz Clock Outputs	7.3-37
Mod In	7.3-17	SPI B Data	7.3-38
1st LO Control Voltage	7.3-18	RX Serial Audio Port (SAP)	7.3-39
VCO Output	7.3-19	SPI Data	7.3-40
Frequency Out (16.8 MHz)	7.3-20	SPI CLK	7.3-41
RX RF Input at Antenna Switch	7.3-21	Universal Chip Select	7.3-42
Antenna Switch Bias	7.3-22	Abacus Chip Select	7.3-43
Preselector Tuning Voltage	7.3-23	RX SSI Data	7.3-44
RX RF Input after Antenna Switch	7.3-24	RX SSI Clock	7.3-45
Analog 5V	7.3-24	RX SSI Frame Sync	7.3-46
Preselector 1 Output	7.3-25		

7.3.3 RF Test Points

The following RF block diagram and accompanying table (Table 7.3-2) shows the location of key probe points (PP) and test points (TP) for the XTS 2500/XTS 2500I radio.

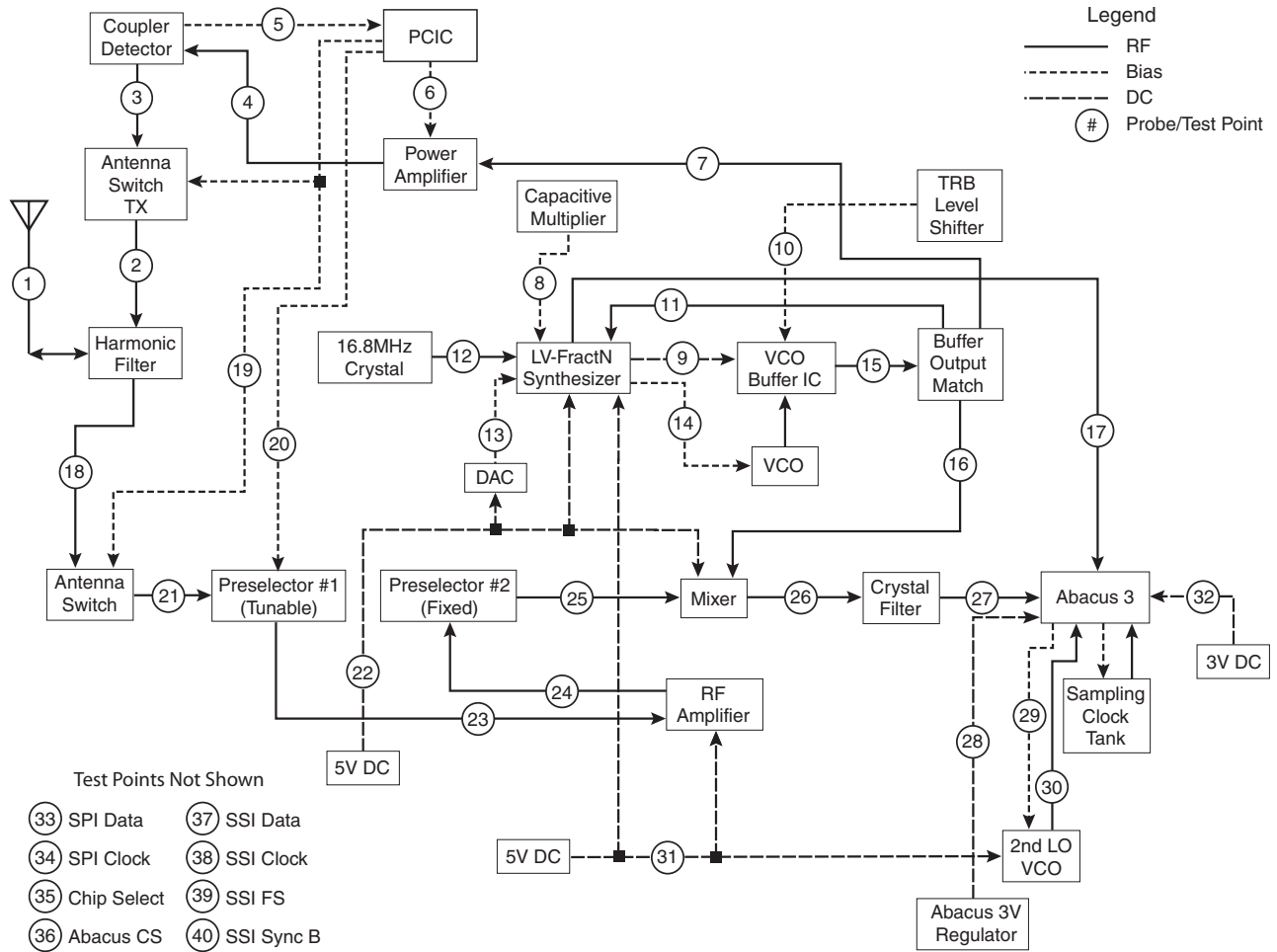

MAEPF-27353-O

Figure 7.3-1. RF Block Diagram Test Points

Table 7.3-2. RF Block Diagram Probe/Test Points

PP/TP	Name	Location	Under RF Shield?	Page
1	Antenna Input	J101, pin 5	No.	7.3-6
2	TX Signal at Harmonic Filter Input	C192	Yes.	7.3-7
3	Coupler RF Out	U103, pin 1	No.	7.3-8
4	TX Signal at PA	Q101, pin 3	No.	7.3-9
5	Coupler RF Feedback to PCIC	TP160	No.	7.3-10
6	PCIC Control Voltage	TP_146	No.	7.3-11
7	TX LO	R289	No.	7.3-12
8	Higher Level Voltage Multiplier	C210	Yes.	7.3-13
9	Superfilter Output	SF_TP	Yes.	7.3-14
11	Prescaler Input to FracN Synthesizer	TP23	Yes.	7.3-15
12	Reference Crystal Output	R729 and C726	No.	7.3-16
13	Mod In	TP36	No.	7.3-17
14	1st LO Control Voltage	VC_TP	No.	7.3-18
15	VCO Output	R266(Rx), R289(Tx) and TP23(prescaler)	Yes.	7.3-19
17	Frequency Out (16.8 MHz)	16out	No.	7.3-20
18	RX RF Input at Antenna Switch	D20, Pin 1	No.	7.3-21
20	Preselector Tuning Voltage	R1 and R2	No.	7.3-23
22	Analog 5V	U500, pin 5	No.	7.3-24
23	Preselector 1 Output	C5	Yes.	7.3-25
24	Low-Noise Amplifier Output	C12	Yes	7.3-26
25	Preselector 2 Output	C18	Yes	7.3-27
26	Mixer Out (IF)	L72	Yes.	7.3-28
27	Crystal Filter Out	L55	Yes	7.3-29
28	Abacus Analog 3V	U501, pin 5	No.	7.3-30
29	2nd LO Control Voltage	U401, pin 38	Yes.	7.3-31
30	2nd LO VCO Buffer Output	C433	Yes.	7.3-32
31	Analog 5V	U500, pin 5	No.	7.3-33
32	Abacus Digital 3V	U502, pin 5	No.	7.3-34
33	SPI Data	R802	No.	7.3-40
34	SPI CLK	R803	No.	7.3-41
35	Universal Chip Select	U102, pin 29	No	7.3-42
36	Abacus Chip Select	U401, pin 25	Yes.	7.3-43
37	RX SSI Data	SSI_D	No.	7.3-44

Table 7.3-2. RF Block Diagram Probe/Test Points (Continued)

PP/TP	Name	Location	Under RF Shield?	Page
38	RX SSI Clock	SSI_CLK	No.	7.3-45
39	RX SSI Frame Sync	SSI_FS	No.	7.3-46

PP = Probe Point
TP = Test Point

Note: For test/probe points indicated with the SH prefix, use an HP 85024A High Frequency Probe to detect a signal. The probe should be placed in center of the hole located on the top of the shield. Make sure the probe does not touch the shield or any other components.

7.3.4 Main Circuit Board RF Shield Locations

Viewed from Side 1

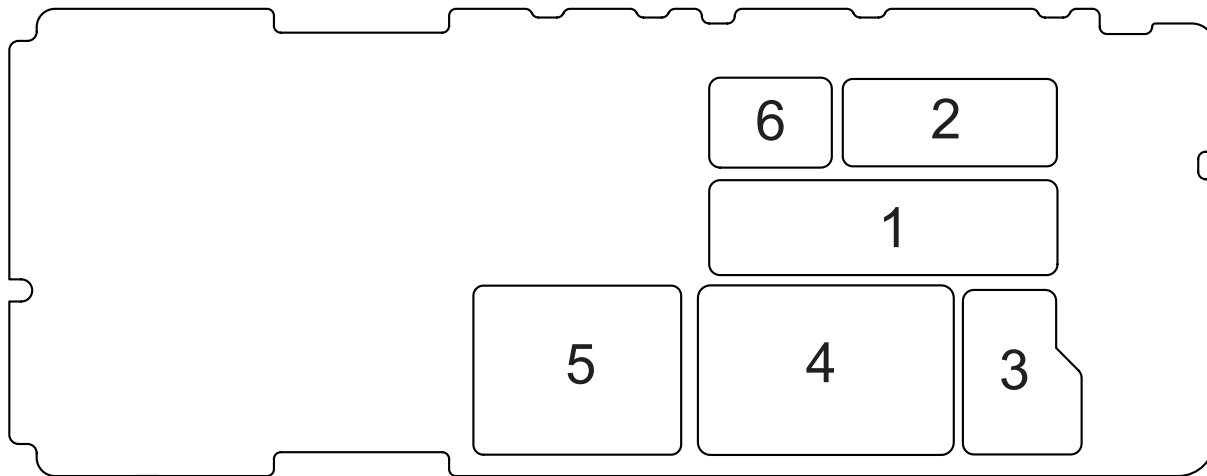

Table 7.3-3. Main Circuit Board Side 1 RF Shields

Item Number	Reference Number	Motorola Part Number	Description
1	SH51	2686700Z02	Shield, Mixer
2	SH402	2686698Z02	Shield, 2nd LO
3	SH102	2686701Z02	Shield, Harmonic Filter
4	SH101	2686702Z02	Shield, TX Driver
5	SH251	2616554H01	Shield, VCO Top
6	SH52	2686699Z02	Shield, Crystal IF

Viewed from Side 2

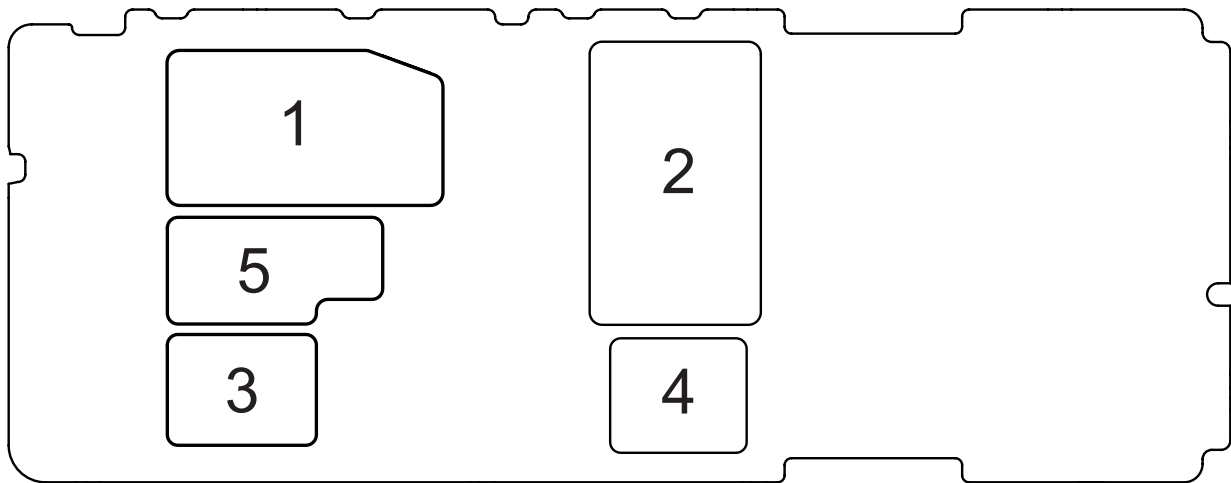
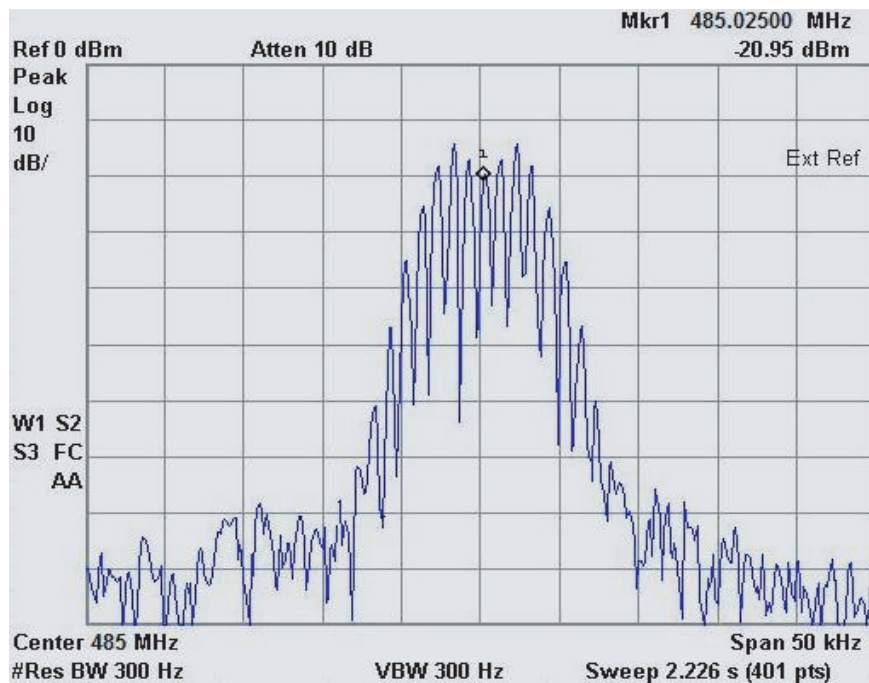
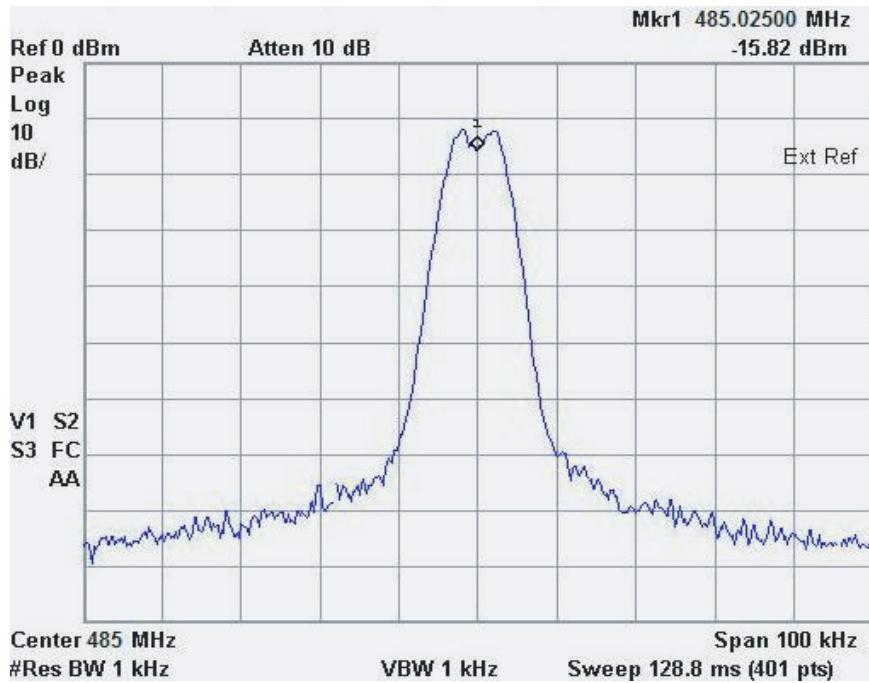

Table 7.3-4. Main Circuit Board Side 2 RF Shields

Item Number	Reference Number	Motorola Part Number	Description
1	SH401	2686706Z02	Shield, ABACUS
2	SH201	2686705Z02	Shield, Synthesizer
3	SH103	2686708Z02	Shield, Coupler Bottom
4	SH252	2616559H01	Shield, VCO Bottom
5	SH1	2686707Z02	Shield, Front End Filter

7.3.5 PP1 Antenna Input



Probe point: J101, pin 5.

Typical RX signal with 1 kHz modulation. Display shows modulation components of carrier.

7.3.6 PP2 TX Signal at Harmonic Filter Input

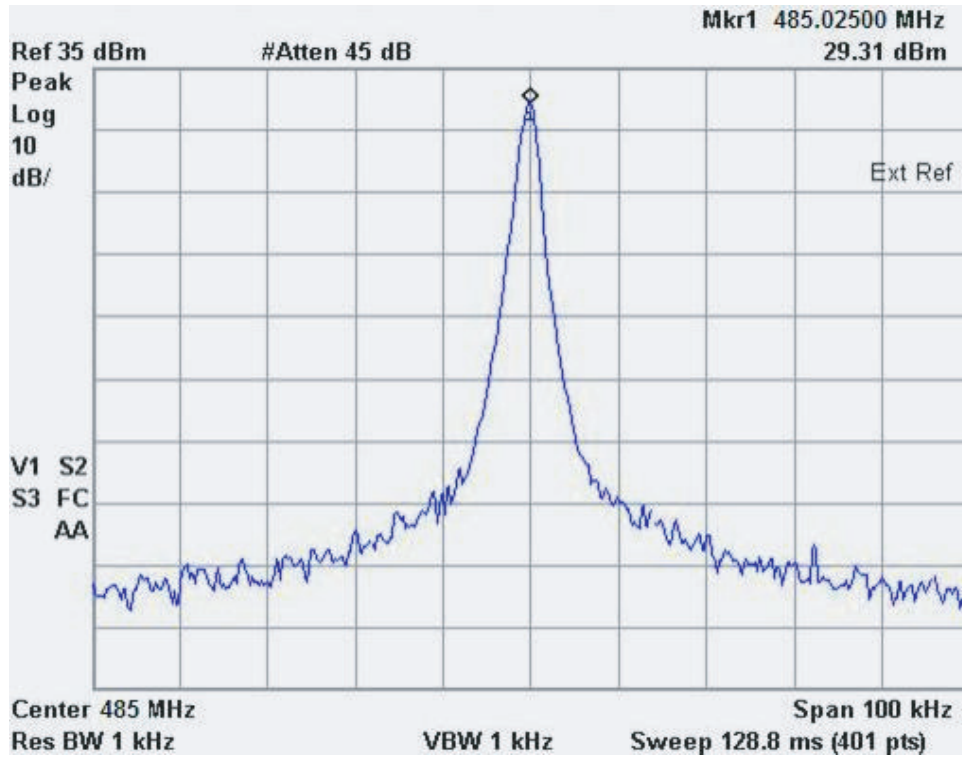

Probe point: C180 (located under shield).

7.3.7 PP3 Coupler RF Out

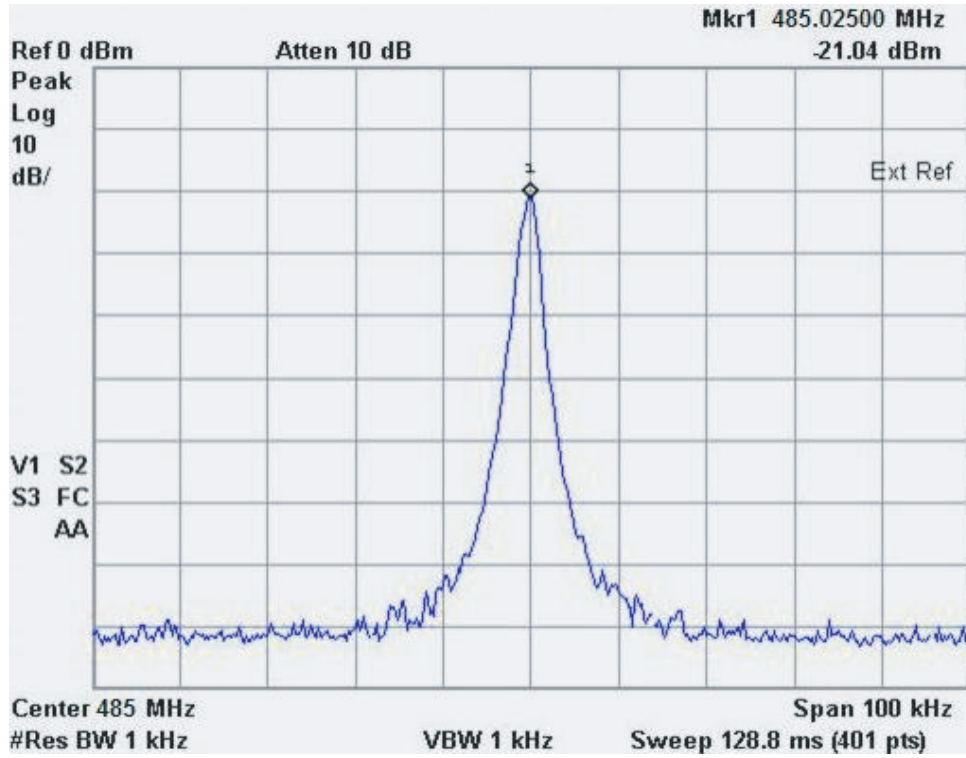

Probe point: U103, pin 1.

7.3.8 PP4 TX Signal at PA

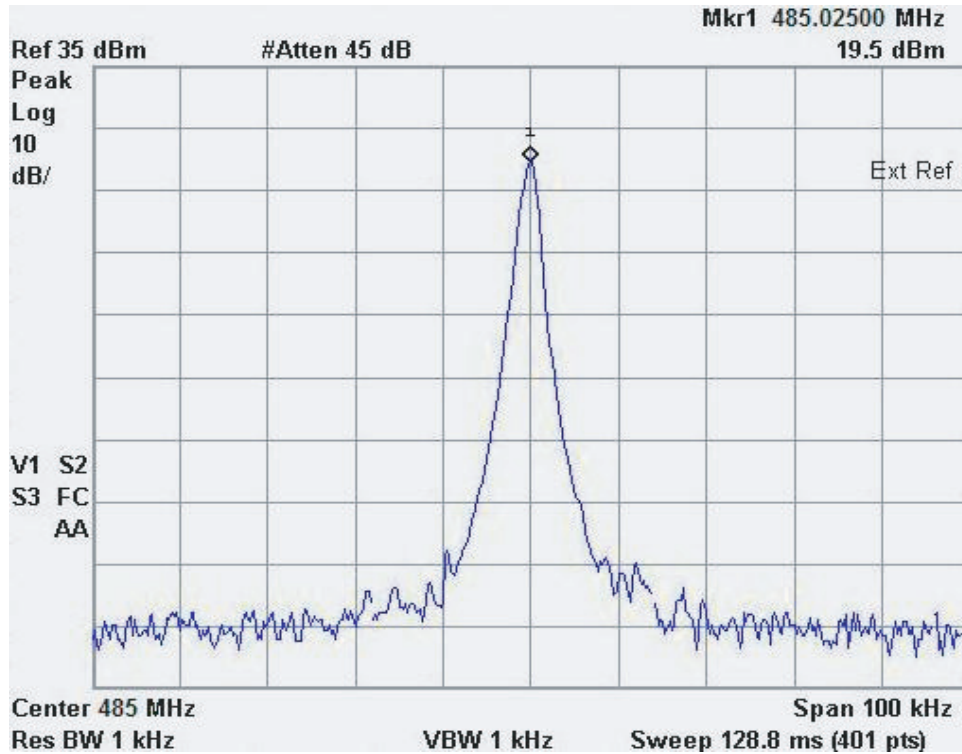

Probe point: Q101, pin 2.

7.3.9 TP5 Coupler RF Feedback to PCIC

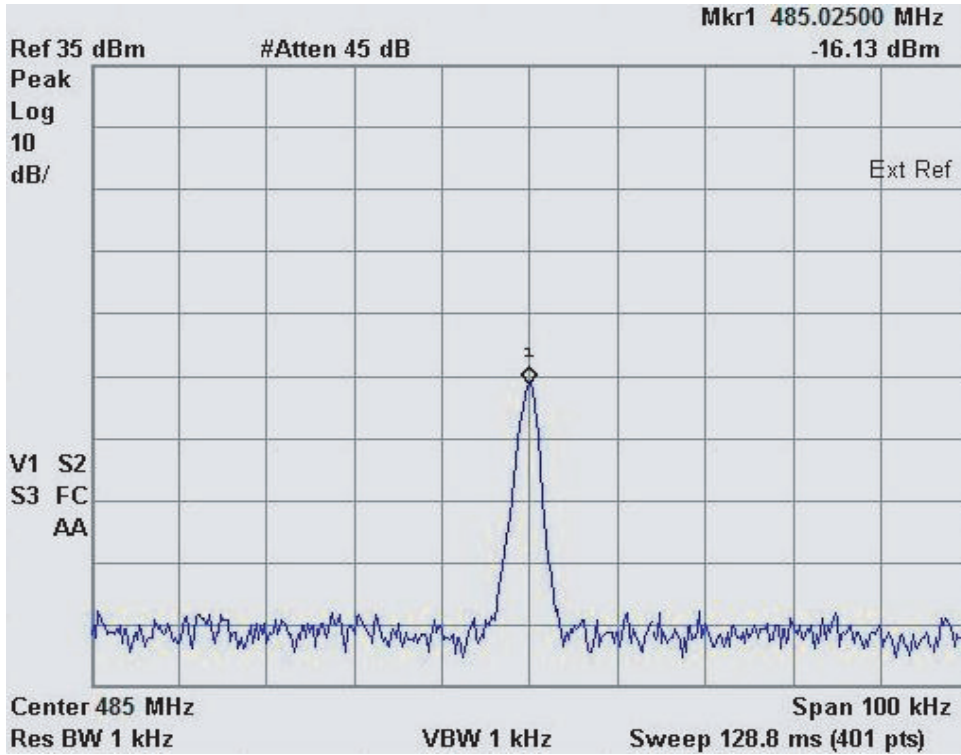

Test point: TP_160.

7.3.10 TP6 PCIC Control Voltage

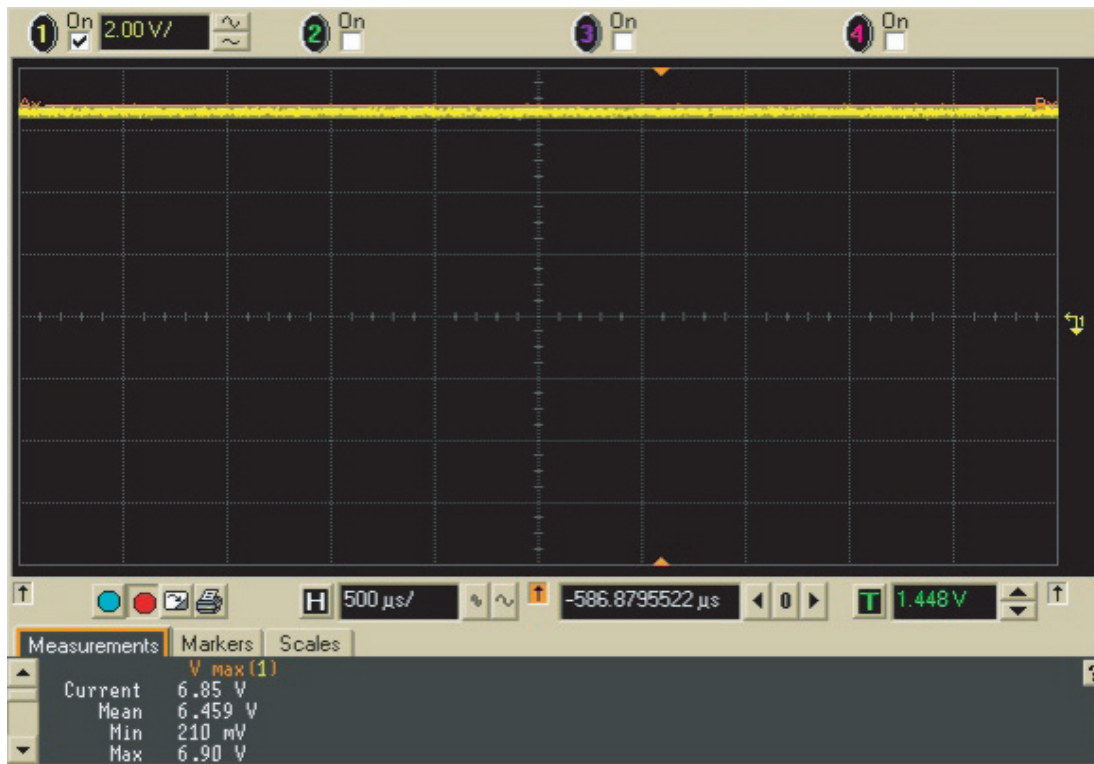

Test point: TP146.

7.3.11 PP7 TX LO

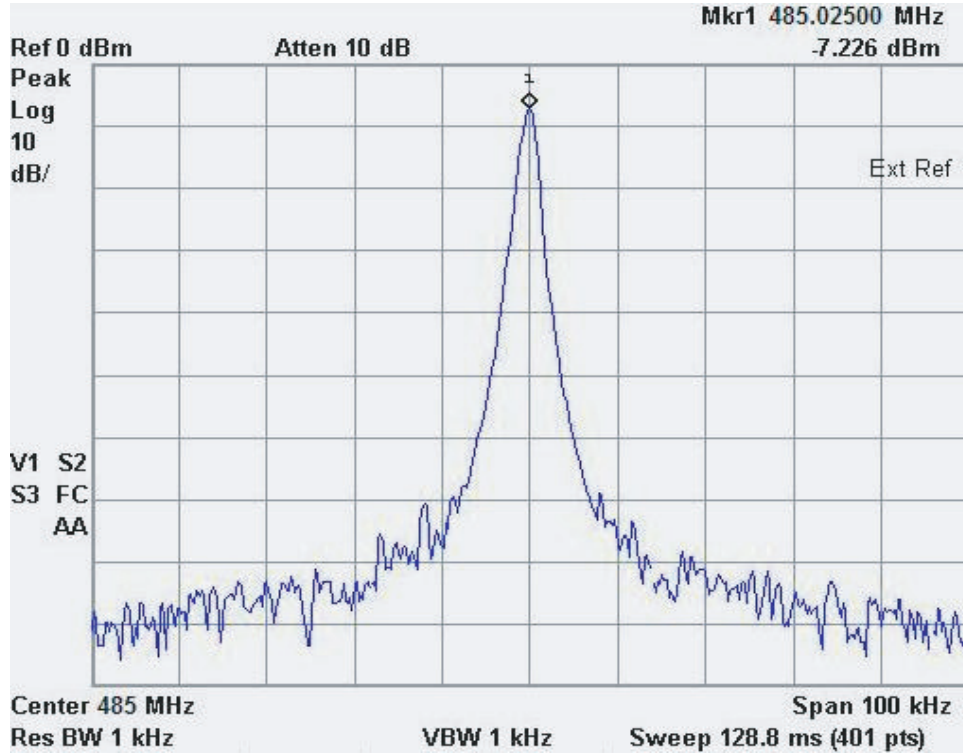

Probe point: TP299.

7.3.12 PP8 Higher Level Voltage Multiplier

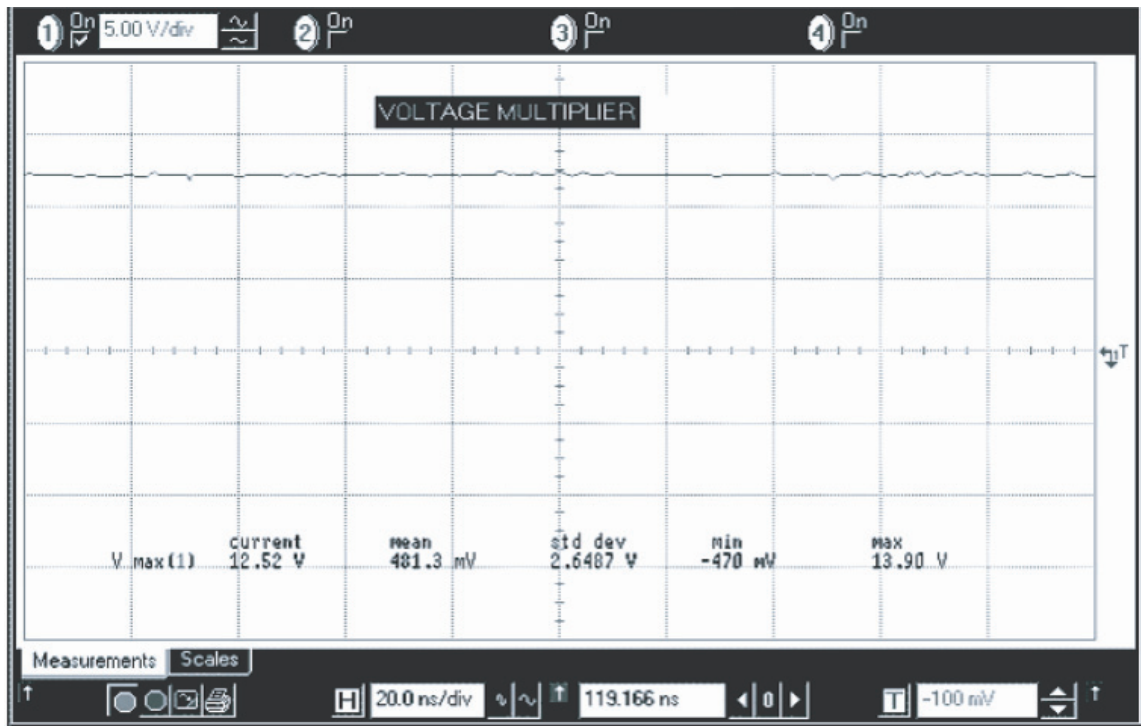

Probe point: C210 (located under shield).

7.3.13 PP9 Superfilter Output

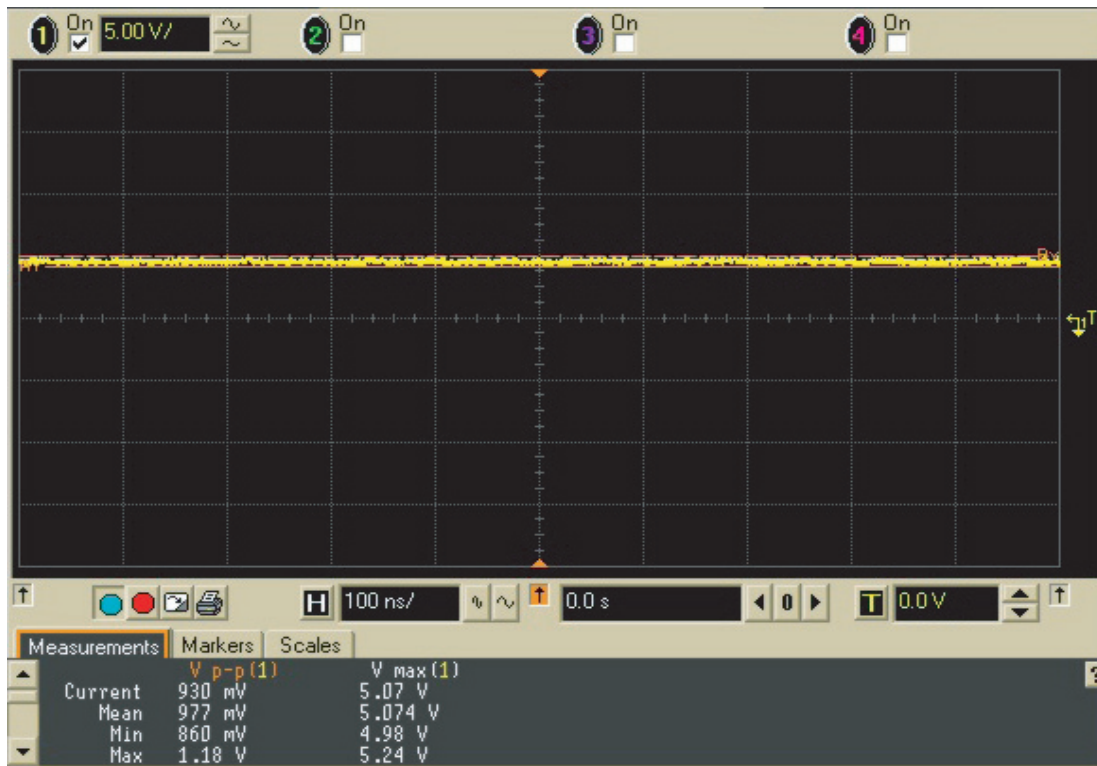

Probe point: SF_TP (located under shield).

7.3.14 PP11 Prescalar Input to FracN Synthesizer

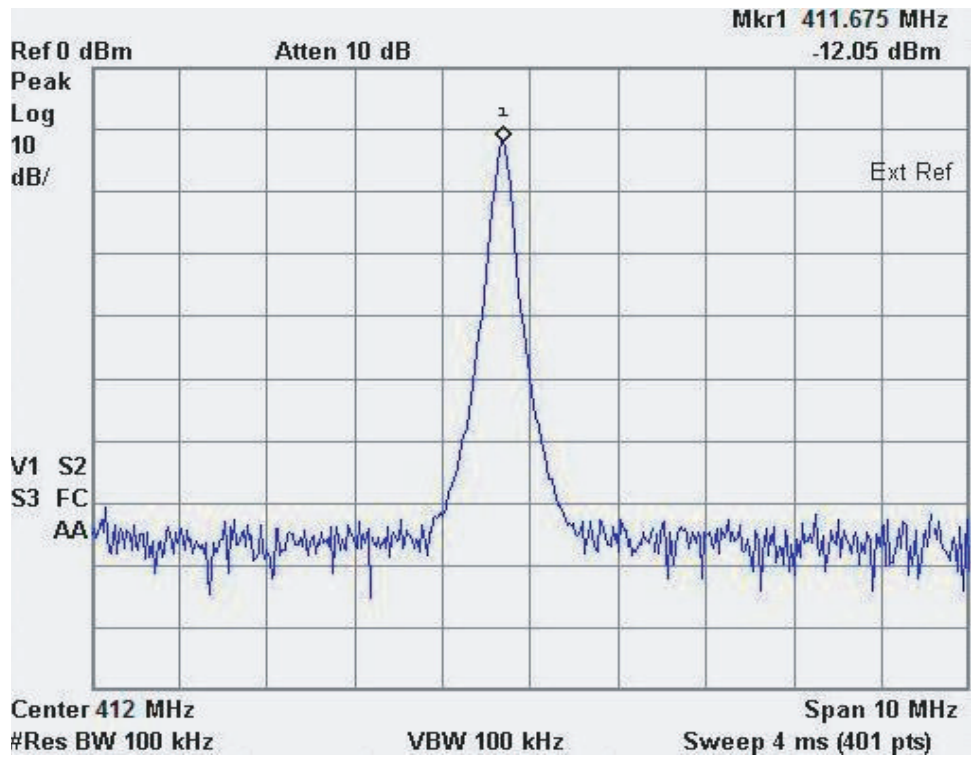

Probe point: TP23 (located under shield).

7.3.15 PP12 Reference Crystal Output

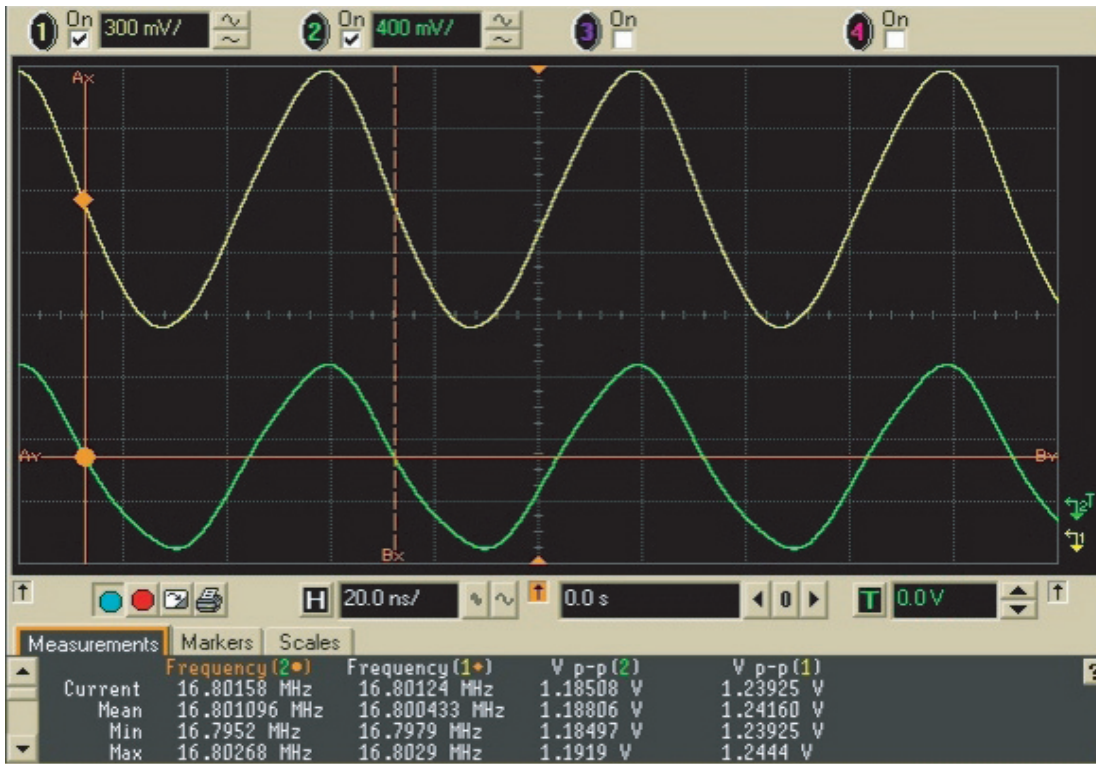

Probe point: R729 (16_8_filtered)
C726 (16_8MHZ).

7.3.16 TP13 Mod In

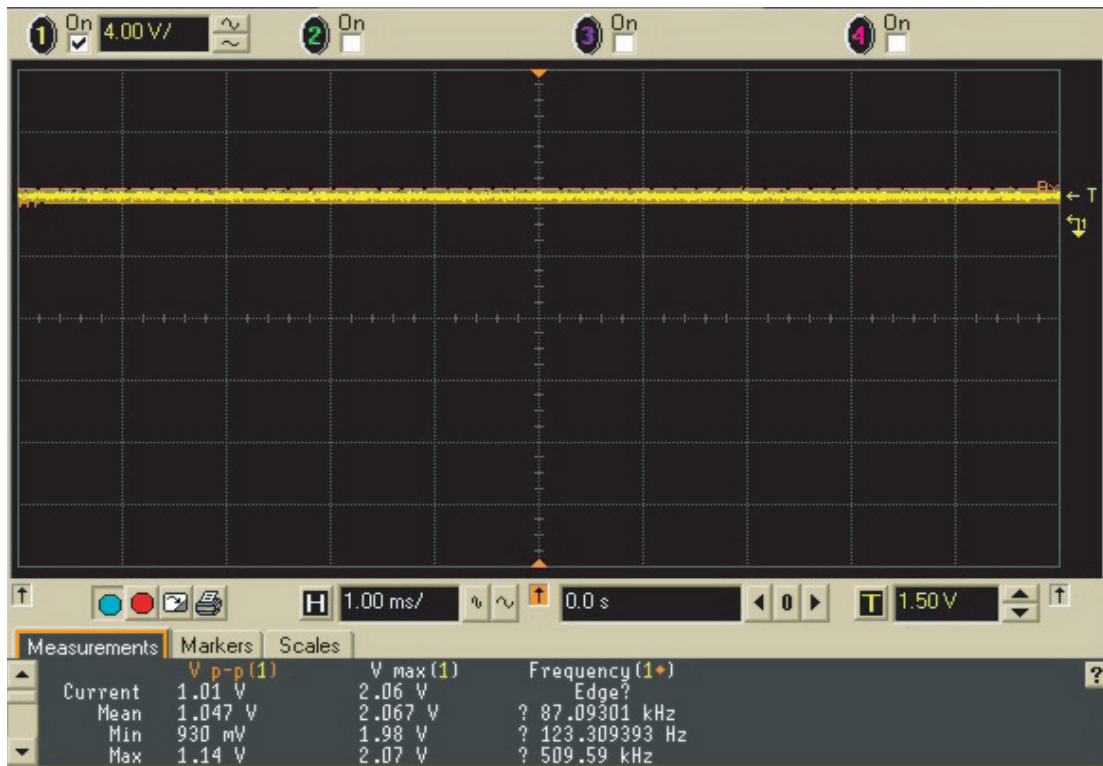

Test point: TP36.

7.3.17 TP14 1st LO Control Voltage

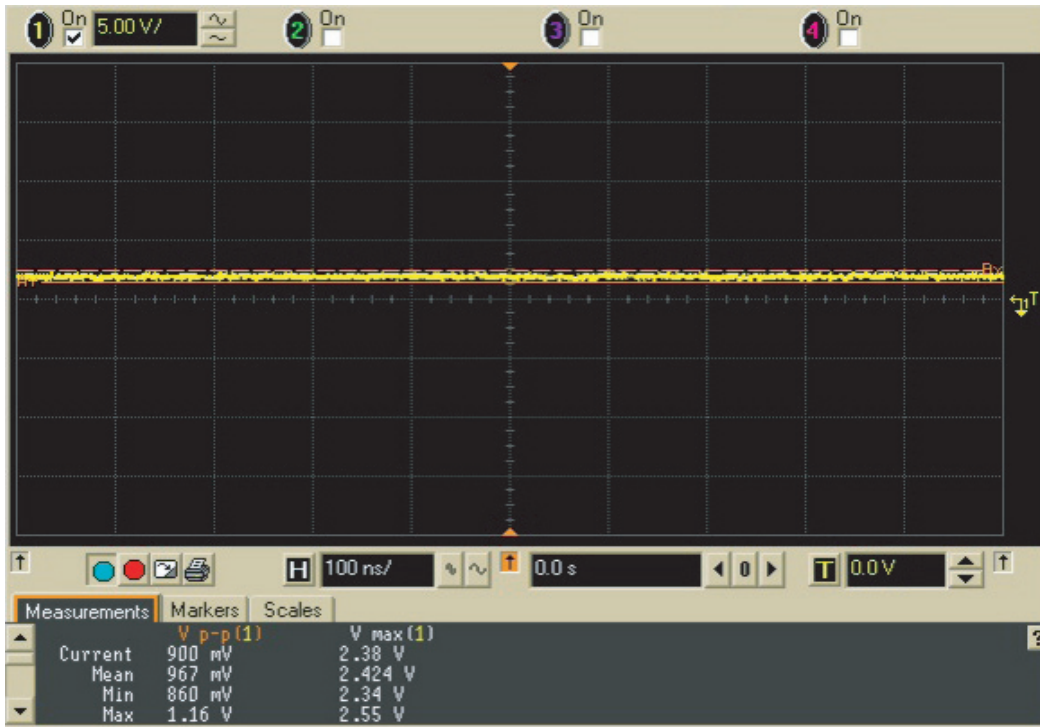

Test point VC_TP

7.3.18 PP15 VCO Output

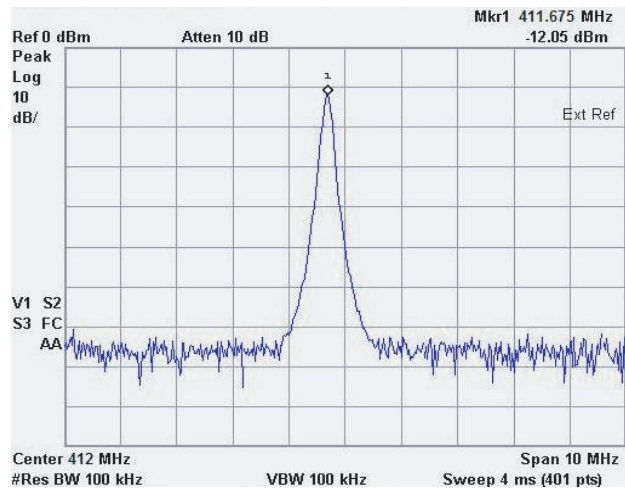
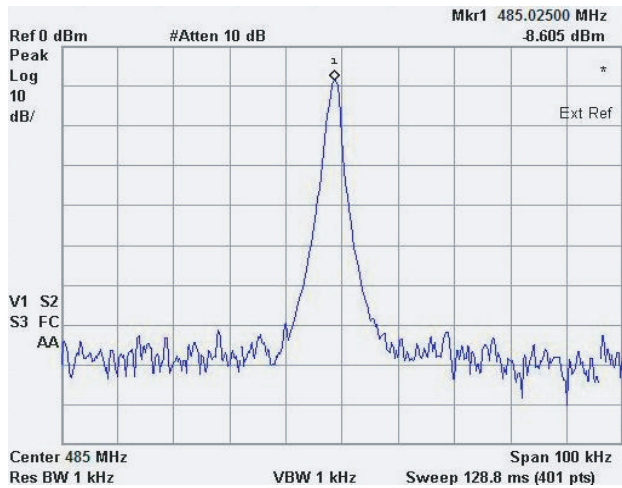
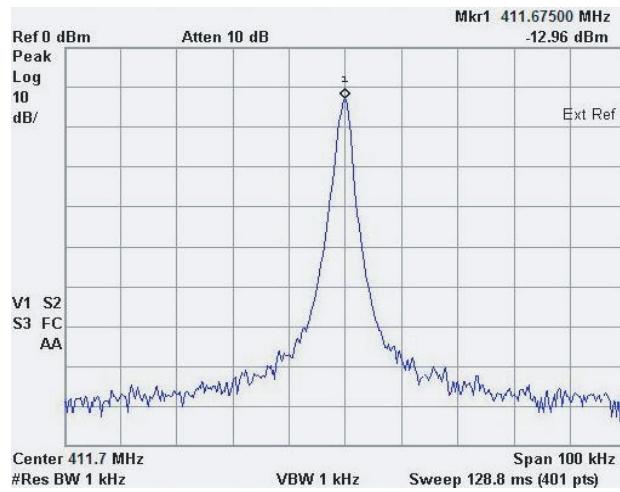

Probe point: TP298 for LO Output
 TP299 for TX Output
 TP23 for Preselector Output (located under shield).

Probe point: C261 (located under shield).

7.3.19 PP17 Frequency Out (19.2 MHz)



Probe point: 16out (Test Point).

7.3.20 PP18 RX RF Input at Antenna Switch

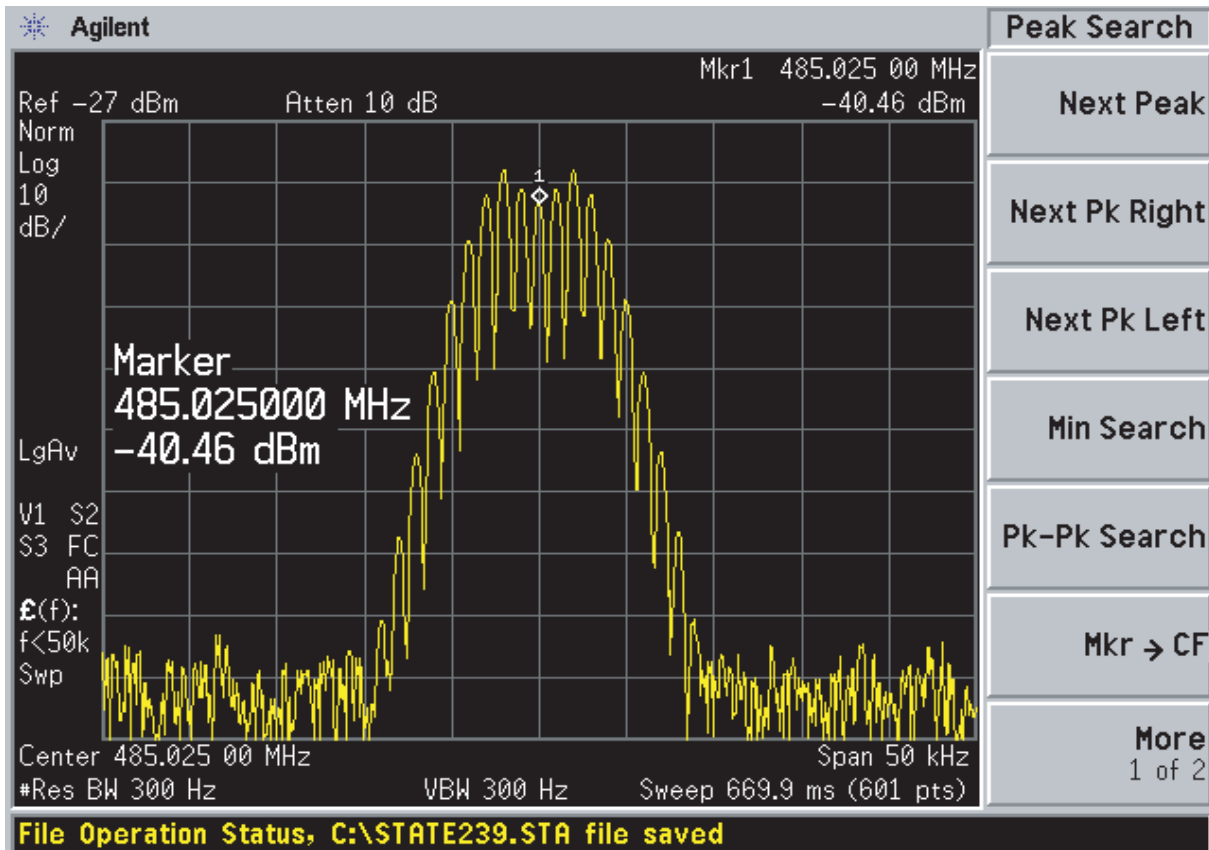

Probe point: C1.

Typical RX signal with 1 kHz modulation. Display shows modulation components of carrier.

7.3.21 PP19 Antenna Switch Bias

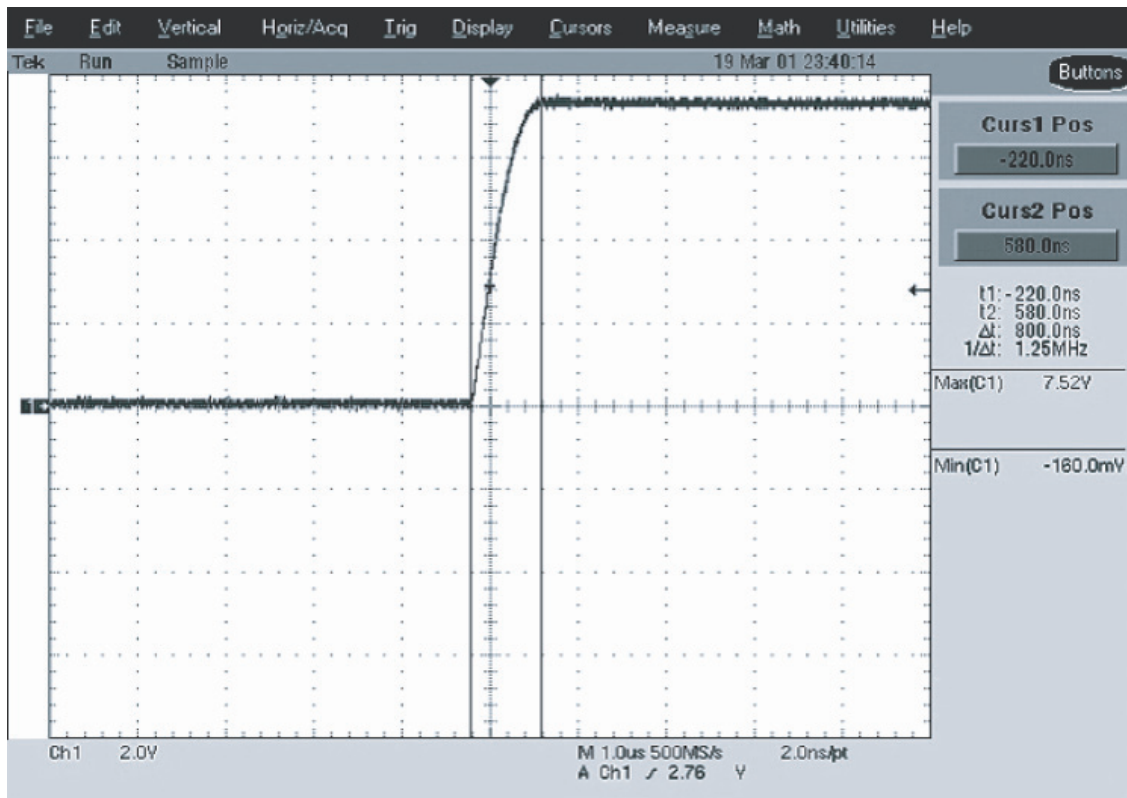

Probe point: U103, pin 1.

Display shows transition between RX mode (low) and TX mode (high).

7.3.22 PP20 Preselector Tuning Voltage

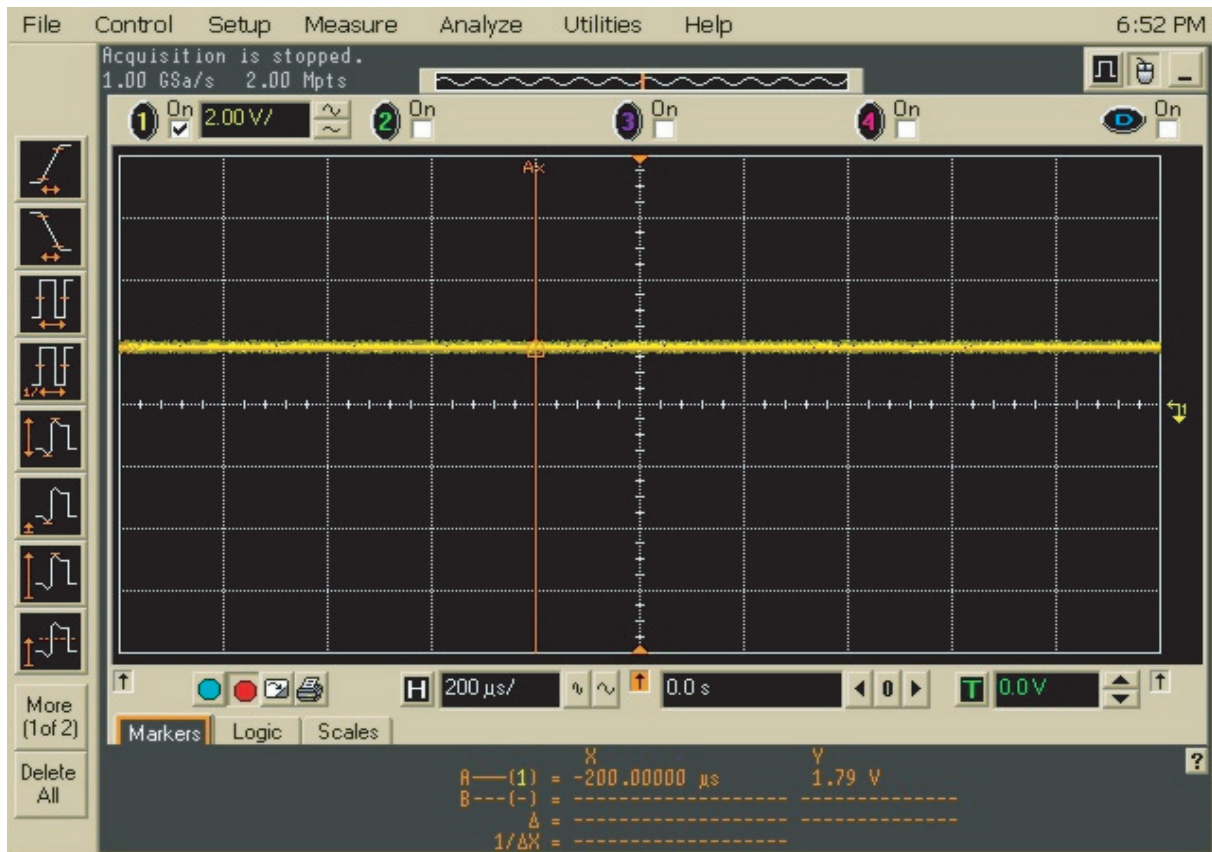

Probe point: C15 and C46.

This is a typical value when tuned to receive at 136.075MHz.

7.3.23 PP22 Analog 5V

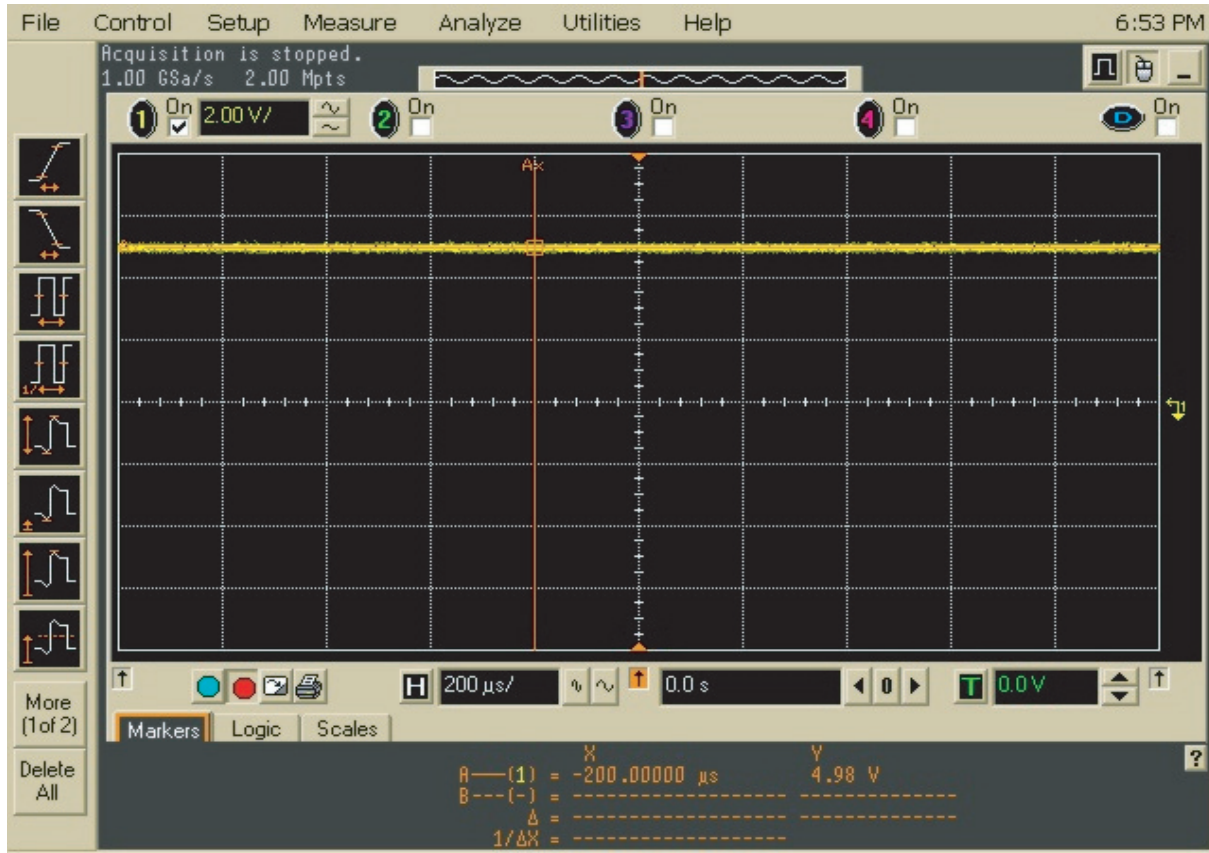

Probe point: U500, pin 5.

7.3.24 PP23 Preselector 1 Output

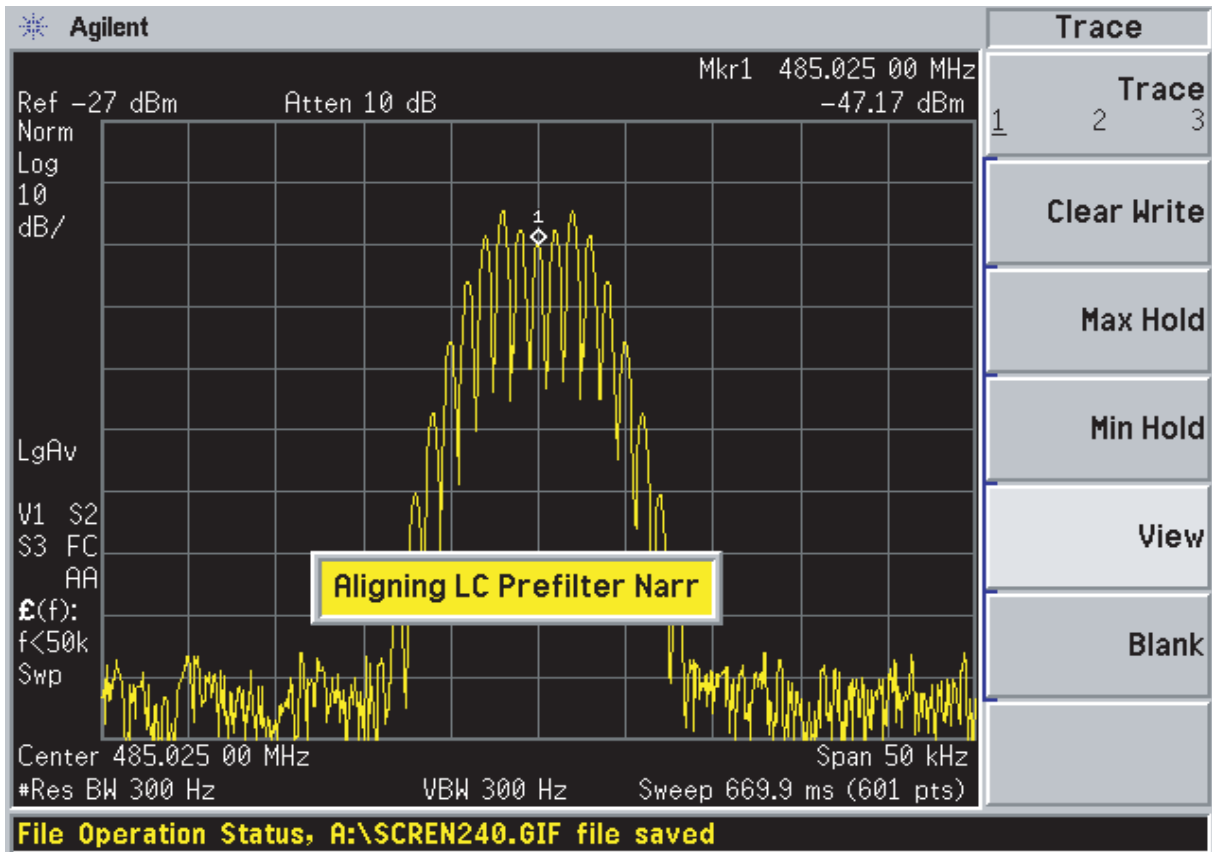

Probe point: C1.

Typical RX signal with 1 kHz modulation. Display shows modulation components of carrier.

7.3.25 PP24 Low-Noise Amplifier Output

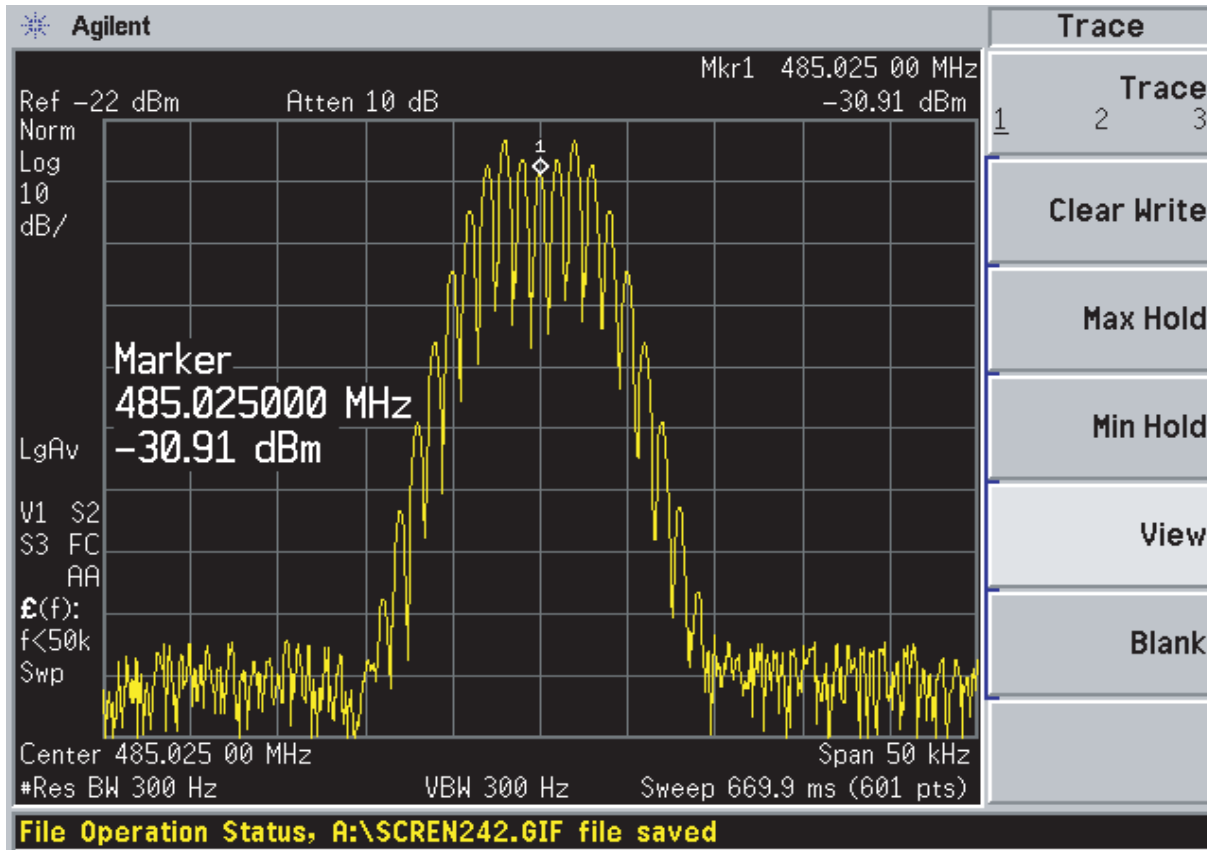

Probe point: C35.

Typical RX signal with 1 kHz modulation. Display shows modulation components of carrier.

7.3.26 PP25 Preselector 2 Output

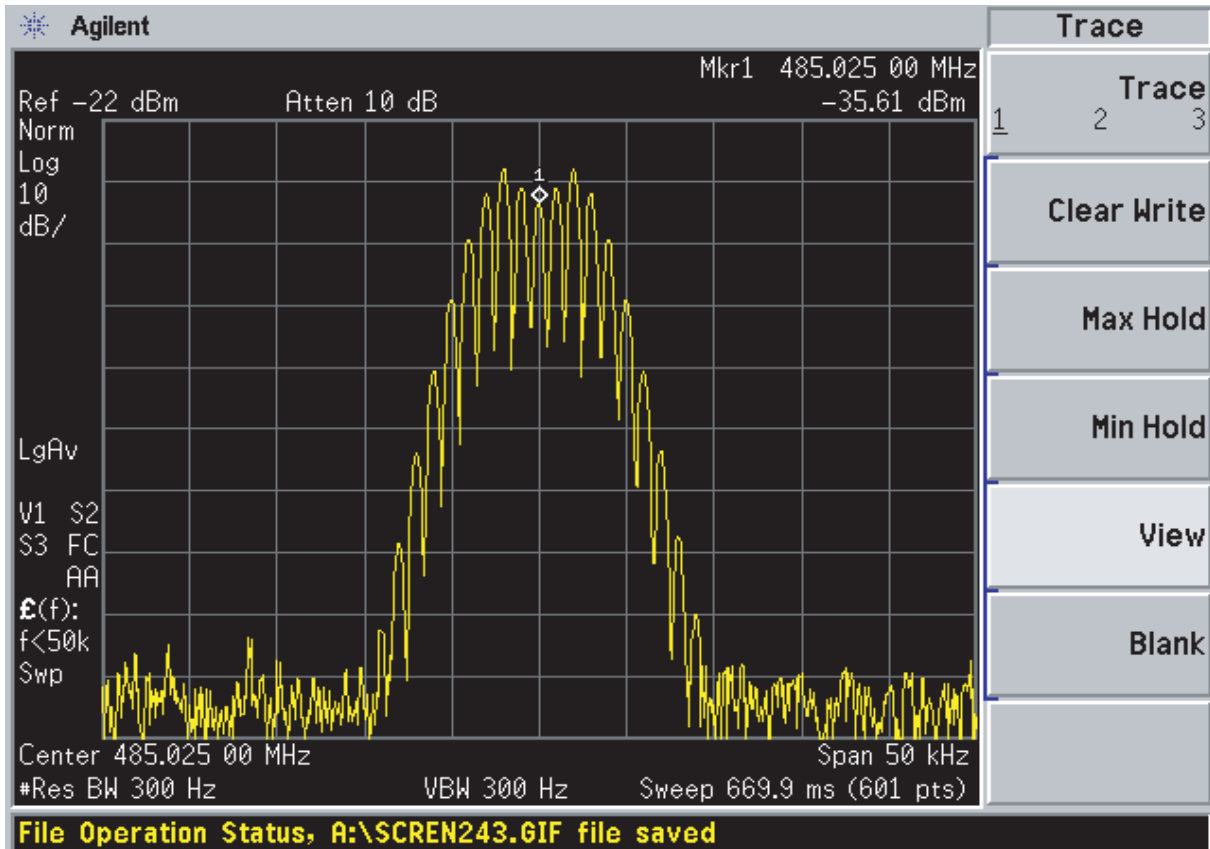

Probe point: C47.

Typical RX signal with 1 kHz modulation. Display shows modulation components of carrier.

7.3.27 PP26 Mixer Out (IF)

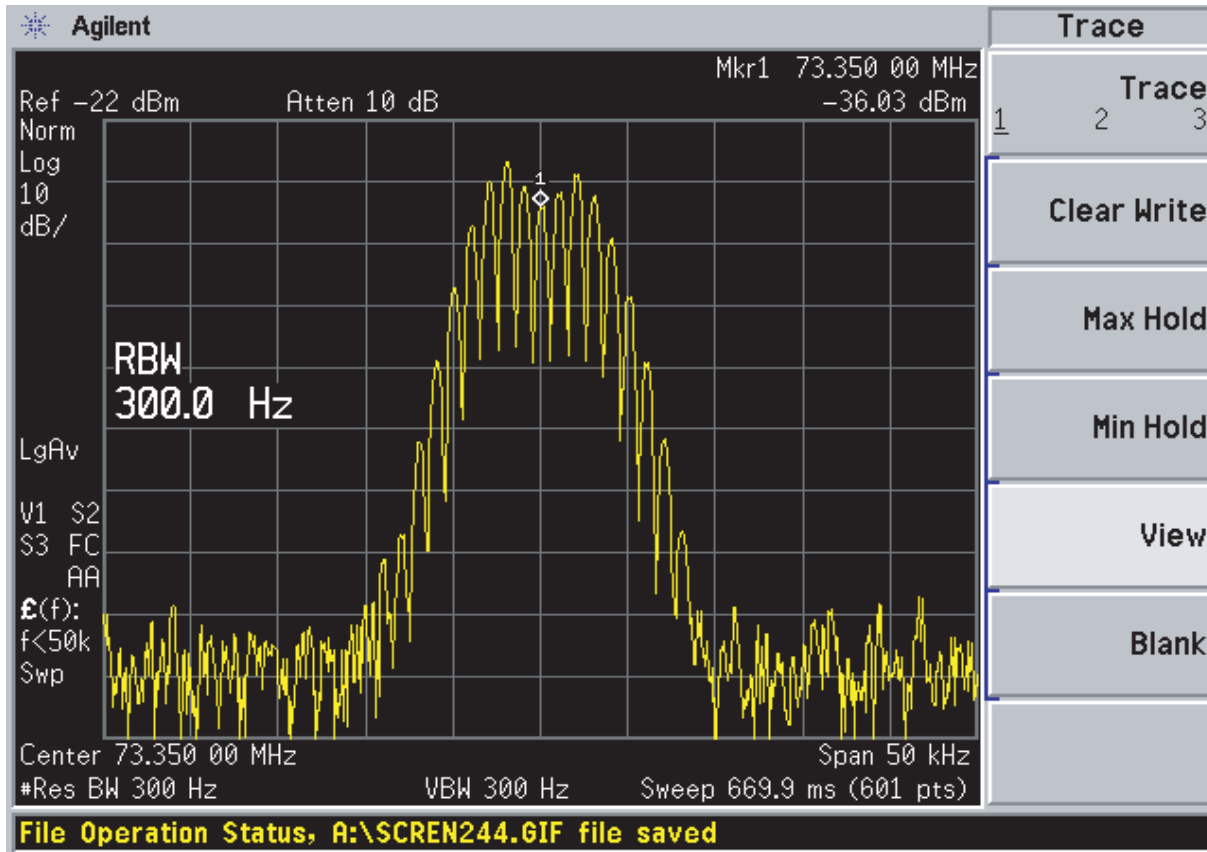

Probe point: C68.

Typical RX signal with 1 kHz modulation. Display shows modulation components of carrier.

7.3.28 PP27 Crystal Filter Out

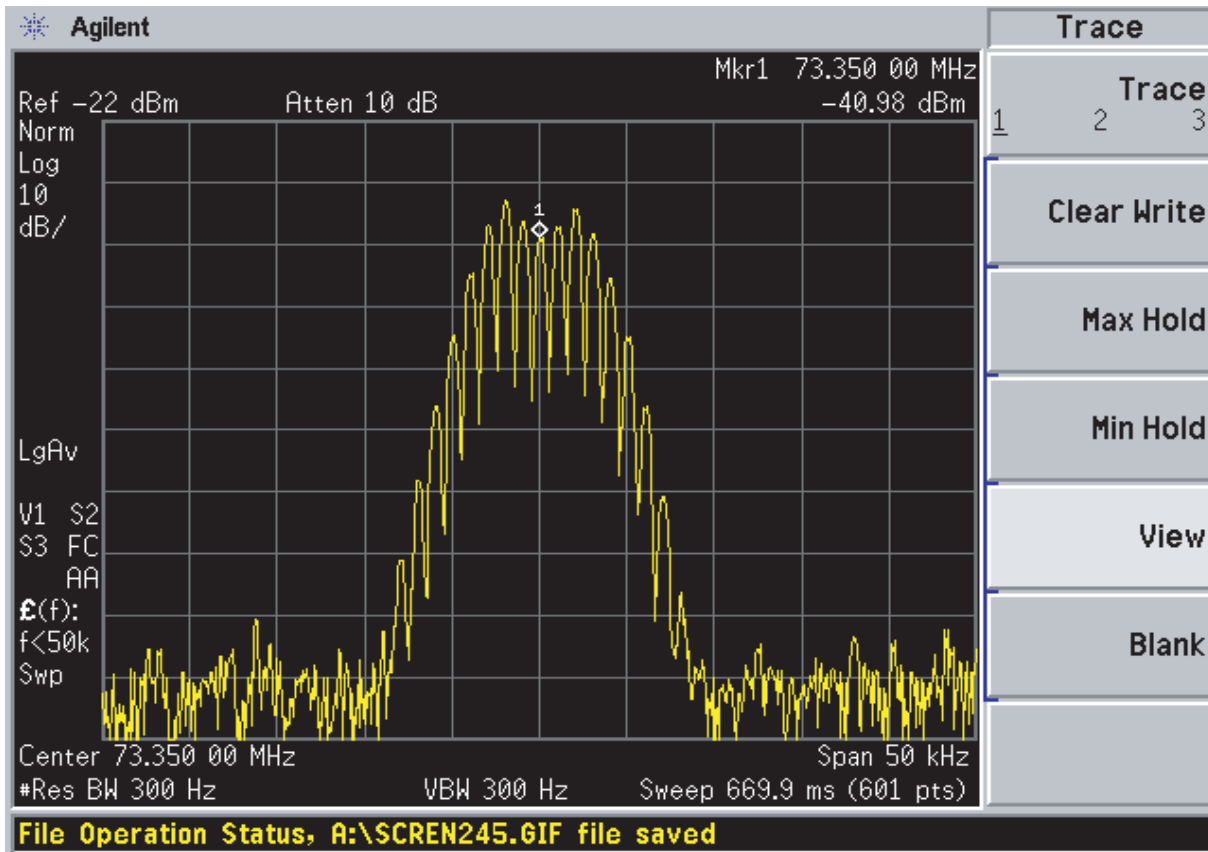

Probe point: L56.

7.3.29 PP28 Abacus Analog 3V

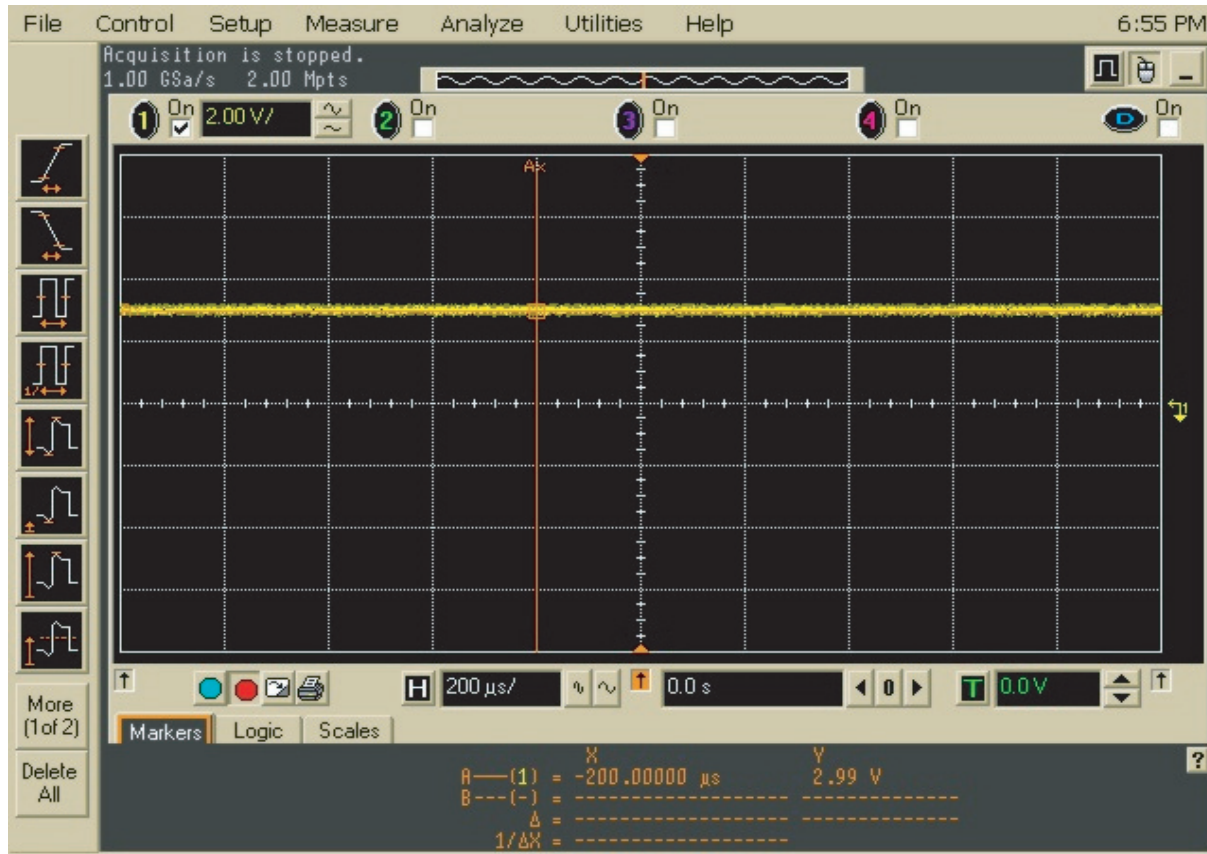

Probe point: U501, pin 5.

7.3.30 PP29 2nd LO Control Voltage

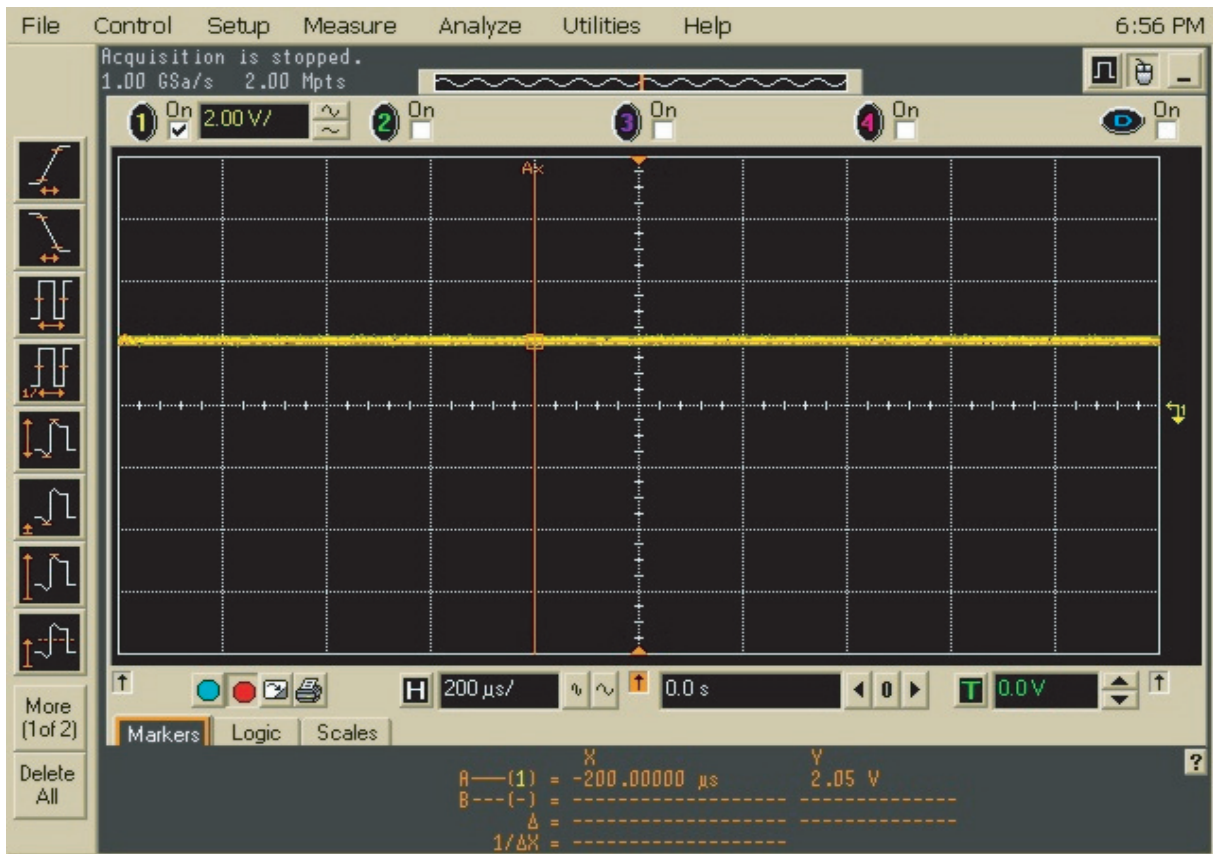

Probe point: U401, pin 38 (located under shield).

7.3.31 PP30 2nd LO VCO Buffer Output

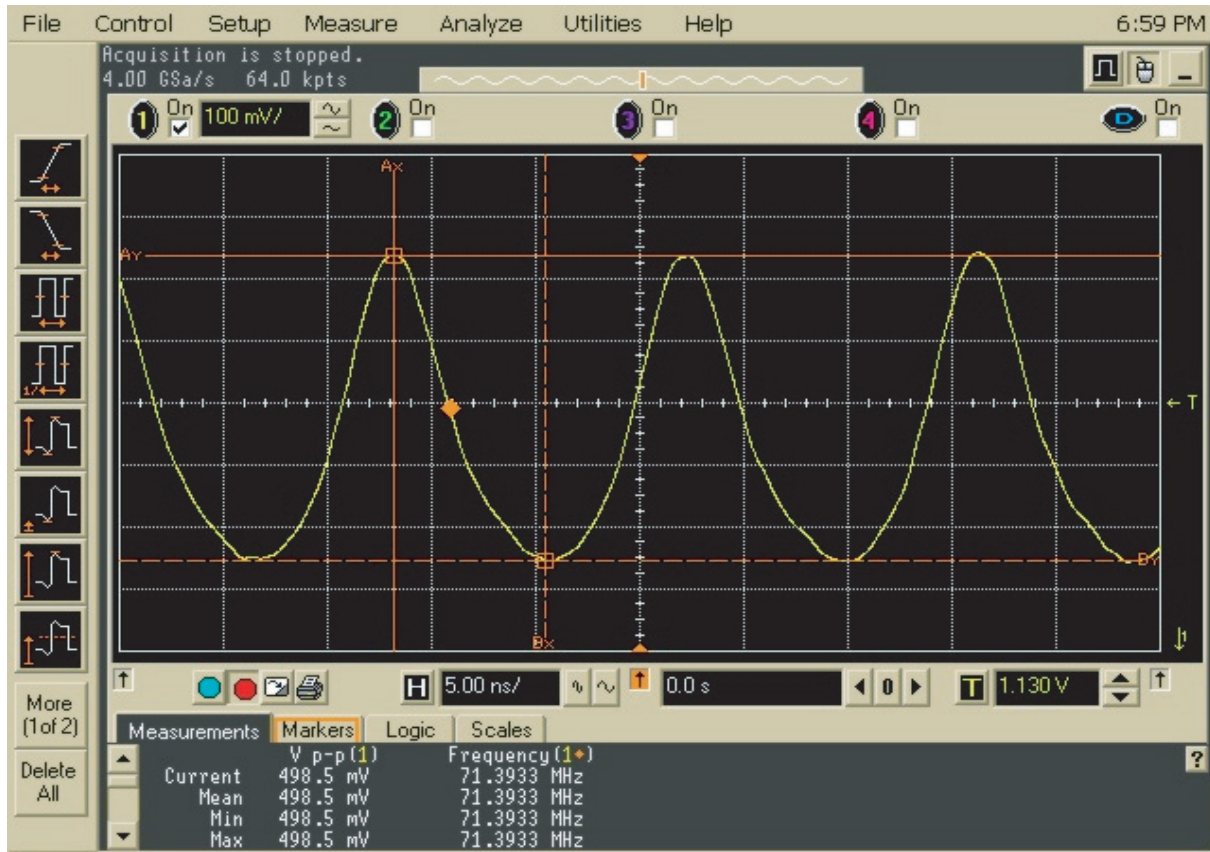

Probe point: C433.

7.3.32 PP31 Analog 5V DC

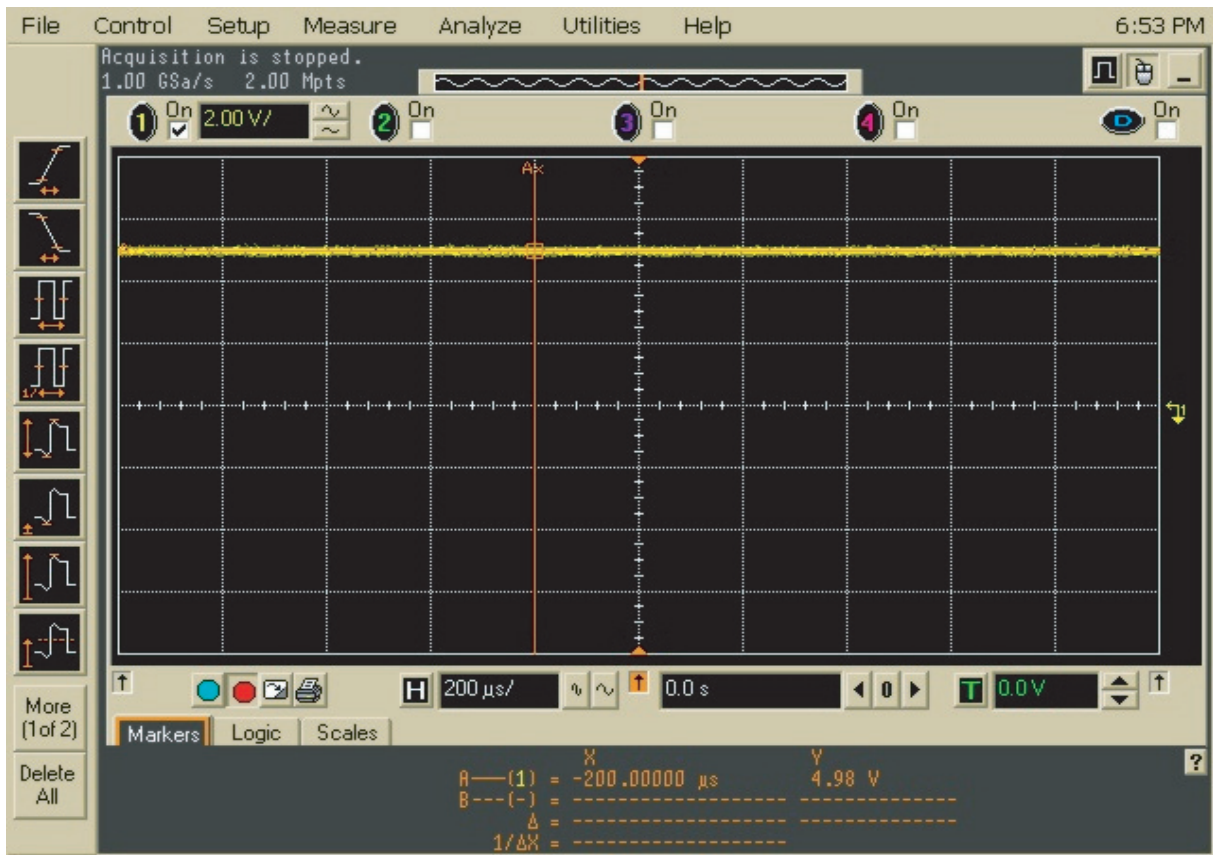

Probe point: U500, pin 5.

7.3.33 PP32 Abacus Digital 3V

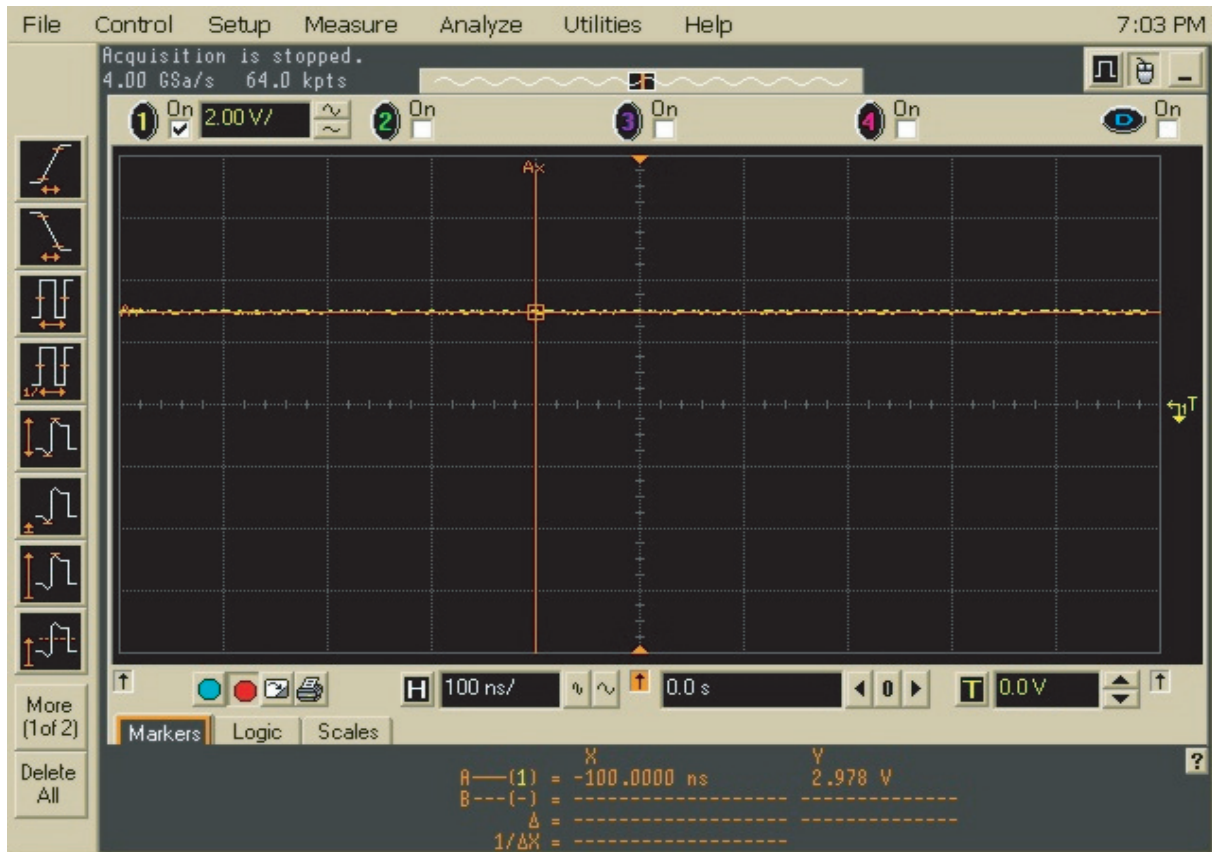

Probe point: U502, pin 5.

7.3.34 TX Audio 1 kHz Tone

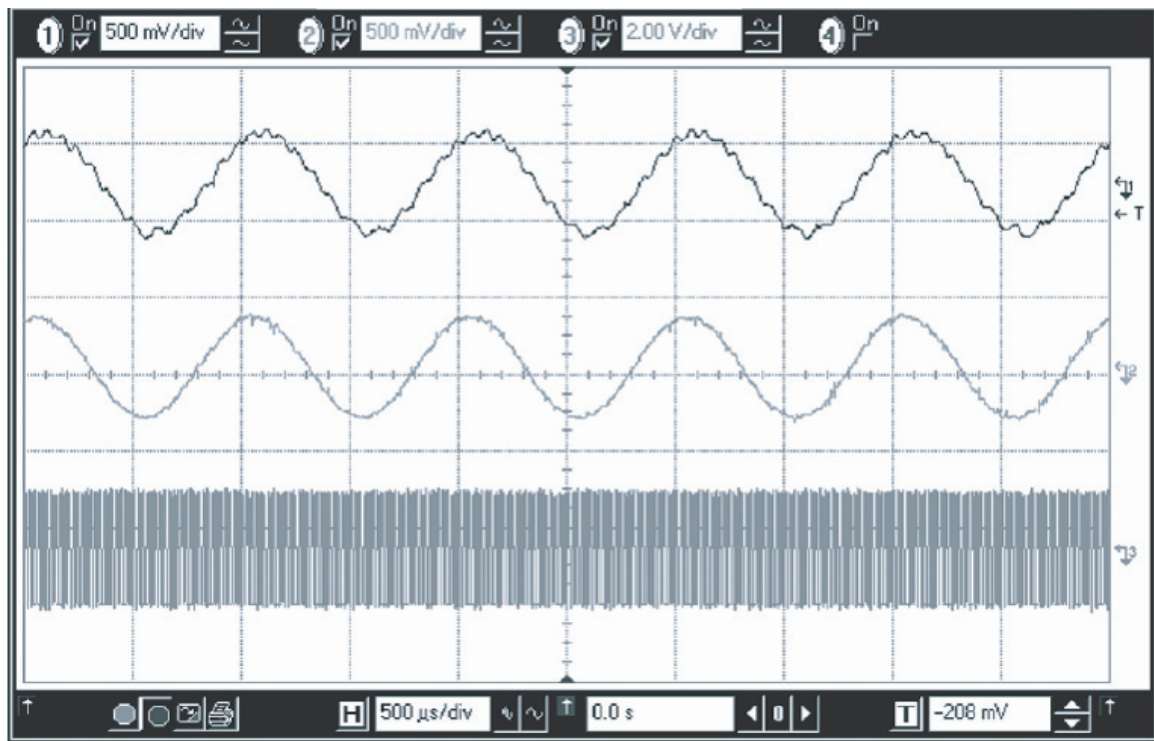

Trace 1: TP23 Mod In (640 mVp-p 1 kHz tone 1.5 Vdc)

Trace 2: U201, pin 1 (620 mVp-p 1 kHz tone)

Trace 3: FL200, pin 8 (1.2 MHz square wave 0 to 3 V)

Note: Transmit audio 1 kHz tone, which provides 3 kHz deviation.

7.3.35 16.8 MHz Buffer Input and Output

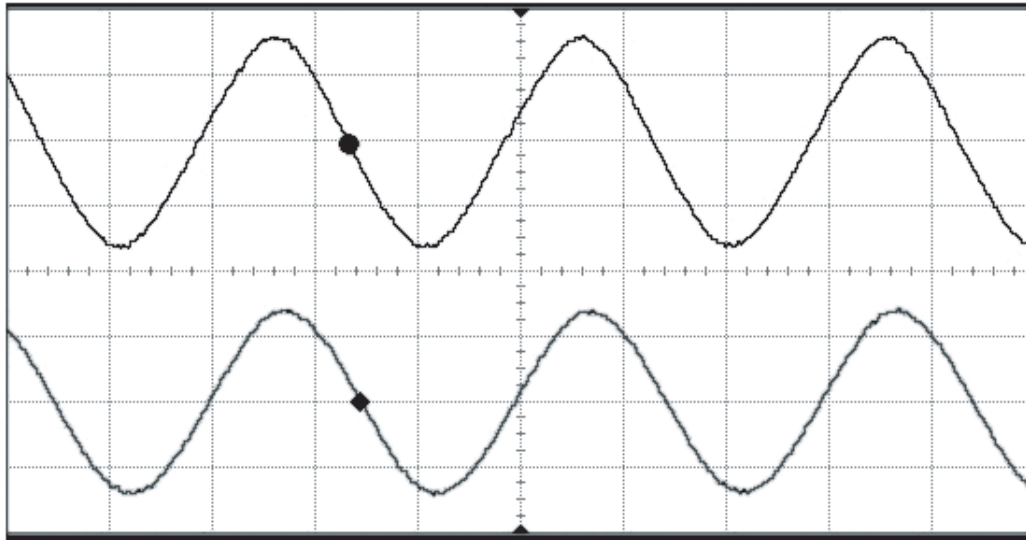

Acquisition Sampling mode real time Normal
 Memory depth automatic 64000 pts
 Sampling rate automatic Sampling rate 4.00 GSa/s
 Averaging off Interpolation on

Channel 1 Scale 300 mV/ Offset 1.546 V
 Coupling DC Impedance 1M Ohm

Channel 4 Scale 400 mV/ Offset 2.154 V
 Coupling DC Impedance 1M Ohm

Time base Scale 20.0 ns/ Position 0.0 s Reference center

Trigger Mode edge Sweep auto
 Sensitivity normal Holdoff time 50 ns Coupling DC
 Source channel 4 Trigger level 1.354 V Slope rising

Measure	V p-p(1)	Frequency(1●)	V p-p(4)	Frequency(4*)
Current	983 mV	16.82001 MHz	1.137 V	16.83329 MHz
Mean ?	977.0 mV	? 16.815154 MHz	1.1378 V	16.802593 MHz
Min ?	57 mV	? 16.63969 MHz	1.008 V	16.65859 MHz
Max ?	993 mV	? 25.09409 MHz	1.237 V	16.94801 MHz
Range ?	936 mV	? 8.454399 MHz	229 mV	289.41886 kHz
Std Dev ?	39.6 mV	? 357.28113 kHz	14.5 mV	53.754484 kHz
# of Meas	551	551	553	553
Edge Dir		Falling		Falling

Trace 1: Buffer input at R729.
Trace 2: Buffer output at C726.

7.3.36 32.768 kHz Clock Outputs

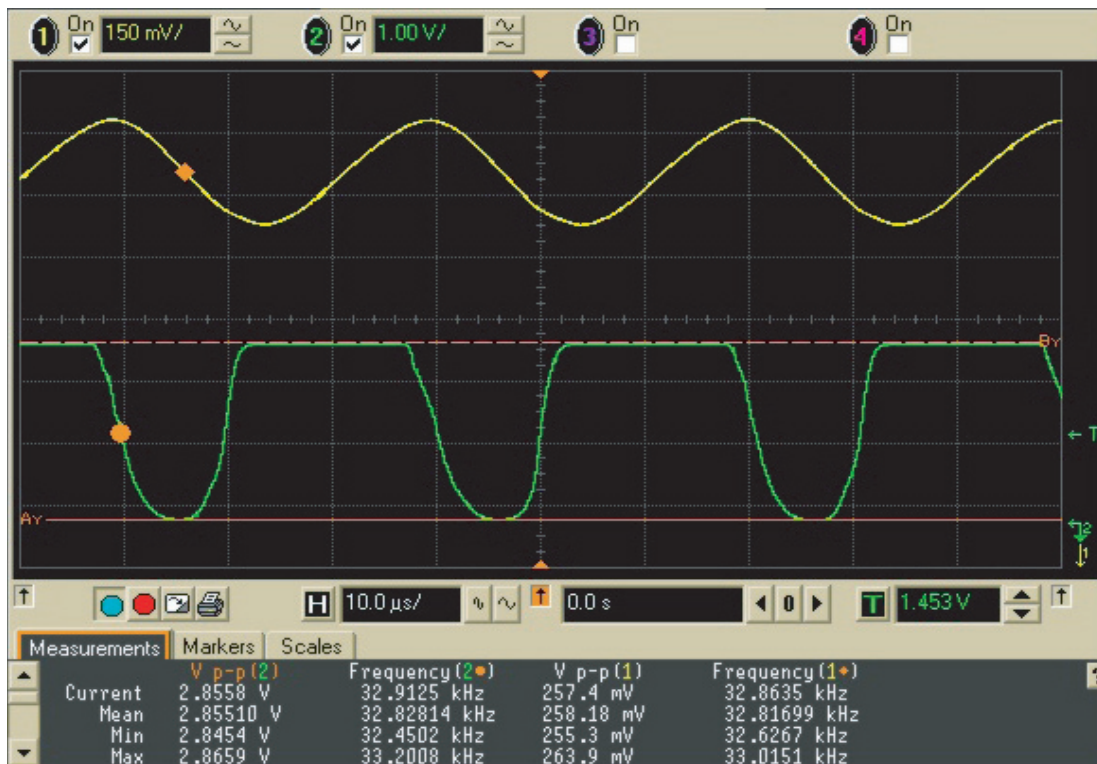

Trace 1: Output at C743.

Trace 2: Output at U712, pin 4.

7.3.37 SPI B Data

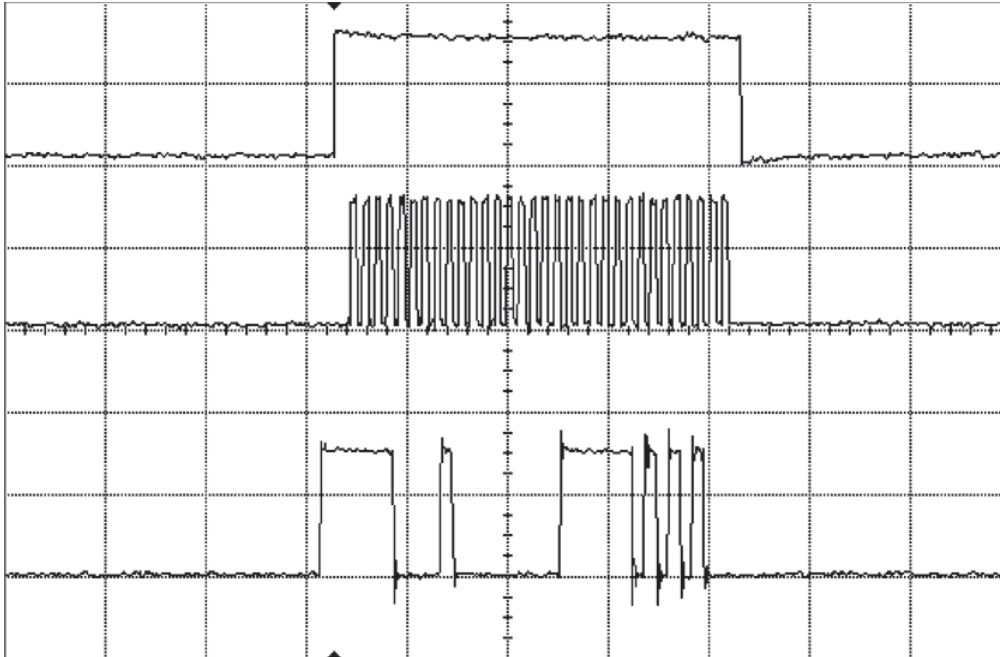

Acquisition Sampling mode real time Configuration 4GSa/s
 Memory depth automatic Memory depth 1004pts
 Sampling rate automatic Sampling rate 50.0 MSa/s
 Averaging off
 9-bit B'W Filter off Interpolation on

Channel 1 Scale 1.99 V/div Offset -4.21 V Coupling DC Impedance 1M Ohm
 Attenuation 10.00 : 1 Atten units ratio Skew 0.0 s
 Ext adapter None Ext coupler None
 Ext gain 1.00E+00 Ext offset 0.0E+00

Channel 2 Scale 2.00 V/div Offset -260 mV Coupling DC Impedance 1M Ohm
 Attenuation 10.00 : 1 Atten units ratio Skew 0.0 s
 Ext adapter None Ext coupler None
 Ext gain 1.00E+00 Ext offset 0.0E+00

Channel 3 Scale 2.00 V/div Offset 5.76 V Coupling DC Impedance 1M Ohm
 Attenuation 10.00 : 1 Atten units ratio Skew 0.0 s
 Ext adapter None Ext coupler None
 Ext gain 1.00E+00 Ext offset 0.0E+00

Time base Scale 2.00 μ s/div Position 3.454546 μ s Reference center

Trigger Mode edge Sweep auto
 Hysteresis normal Holdoff time 60 ns Coupling DC
 Source channel 1 Trigger level 810 mV Slope rising

Trace 1: MAKO chip enable, R767 (not active high)
Trace 2: SPI data clock, C619
Trace 3: SPI data to MAKO, C617.

7.3.38 RX Serial Audio Port (SAP)

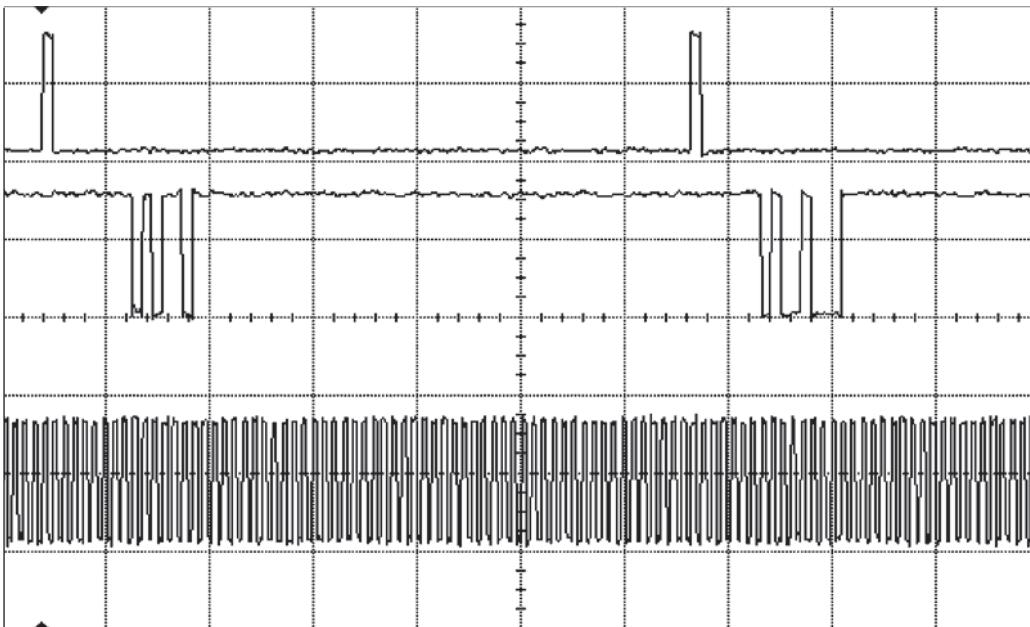

Acquisition	Sampling mode real time Configuration 4GSa/s Memory depth automatic Memory depth 1004pts Sampling rate automatic Sampling rate 5.00 MSa/s Averaging off 9-bit BW Filter off Interpolation on
Channel 1	Scale 1.99 V/div Offset -4.21 V Coupling DC Impedance 1M Ohm Attenuation 10.00 : 1 Atten units ratio Skew 0.0 s Ext adapter None Ext coupler None Ext gain 1.00E+00 Ext offset 0.0E+00
Channel 2	Scale 2.00 V/div Offset -210 mV Coupling DC Impedance 1M Ohm Attenuation 10.00 : 1 Atten units ratio Skew 0.0 s Ext adapter None Ext coupler None Ext gain 1.00E+00 Ext offset 0.0E+00
Channel 3	Scale 2.00 V/div Offset 5.55 V Coupling DC Impedance 1M Ohm Attenuation 10.00 : 1 Atten units ratio Skew 0.0 s Ext adapter None Ext coupler None Ext gain 1.00E+00 Ext offset 0.0E+00
Time base	Scale 20.0 μ s/div Position 92.181816 μ s Reference center
Trigger	Mode edge Sweep auto Hysteresis normal Holdoff time 60 ns Coupling DC Source channel 1 Trigger level 810 mV Slope rising

Note: TX is identical, except the data is probed at test point "TX".

Trace 1: 8 kHz frame sync (each word is 13 bits after falling edge of FSYNC)

Trace 2: SAP data at R626 (audio data from MAKO CODEC to Patriot DSP)

Note: Transmit is identical, except data acquired at R625

Trace 3: 512kHz bit clock at R616. (Codec_DCLK).

7.3.39 PP33 SPI Data

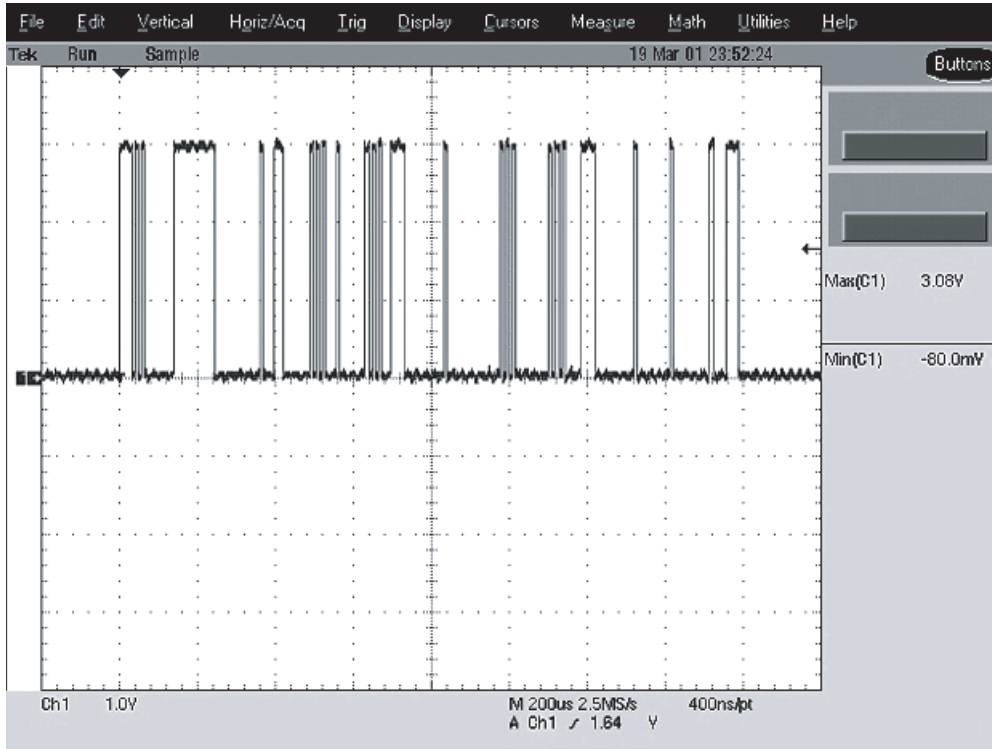

Probe Point: R802.

7.3.40 PP34 SPI CLK

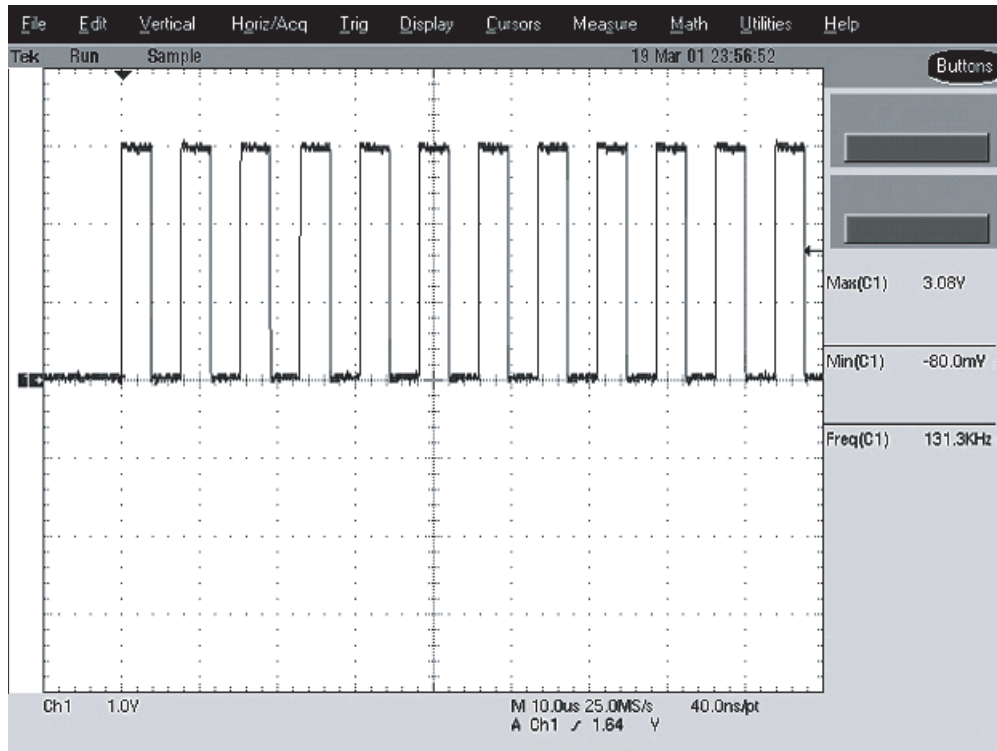

Probe Point: R803.

7.3.41 PP35 Universal Chip Select

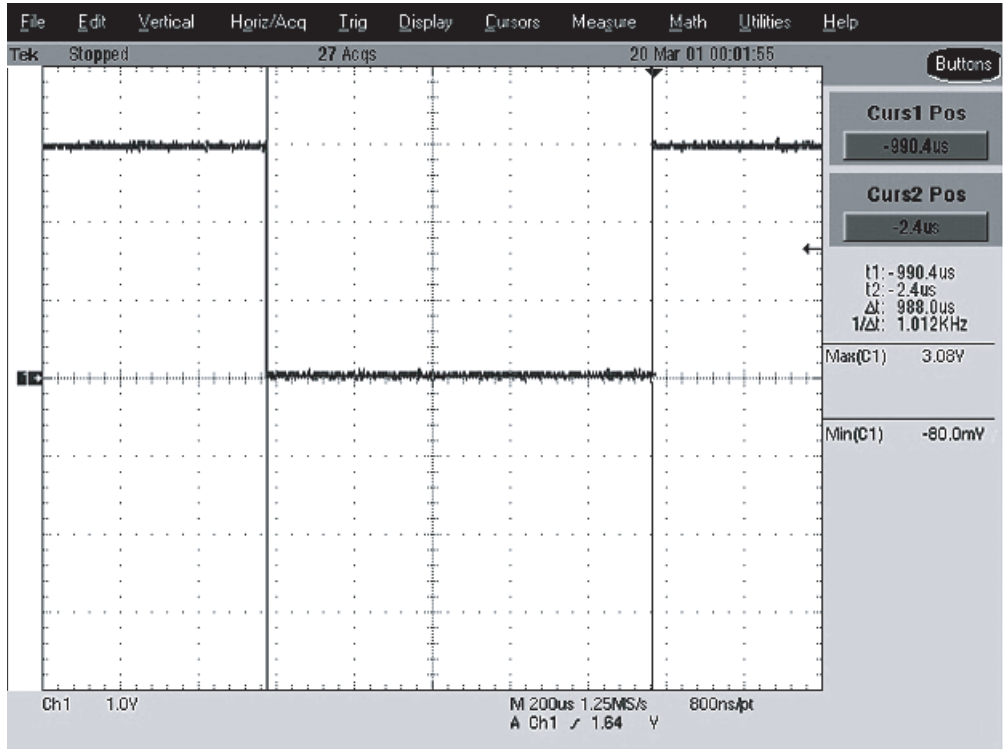

Probe Point: U102, pin 29 (located under shield).

7.3.42 PP36 Abacus Chip Select

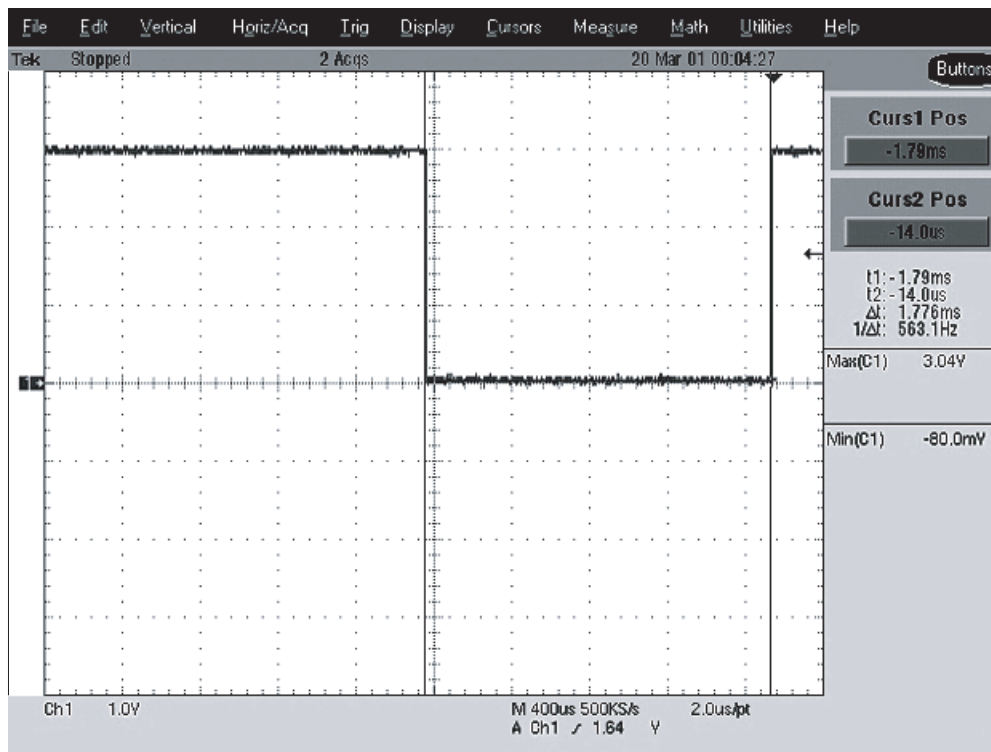

Probe Point: U401, pin 25 (located under shield).

7.3.43 TP37 RX SSI Data

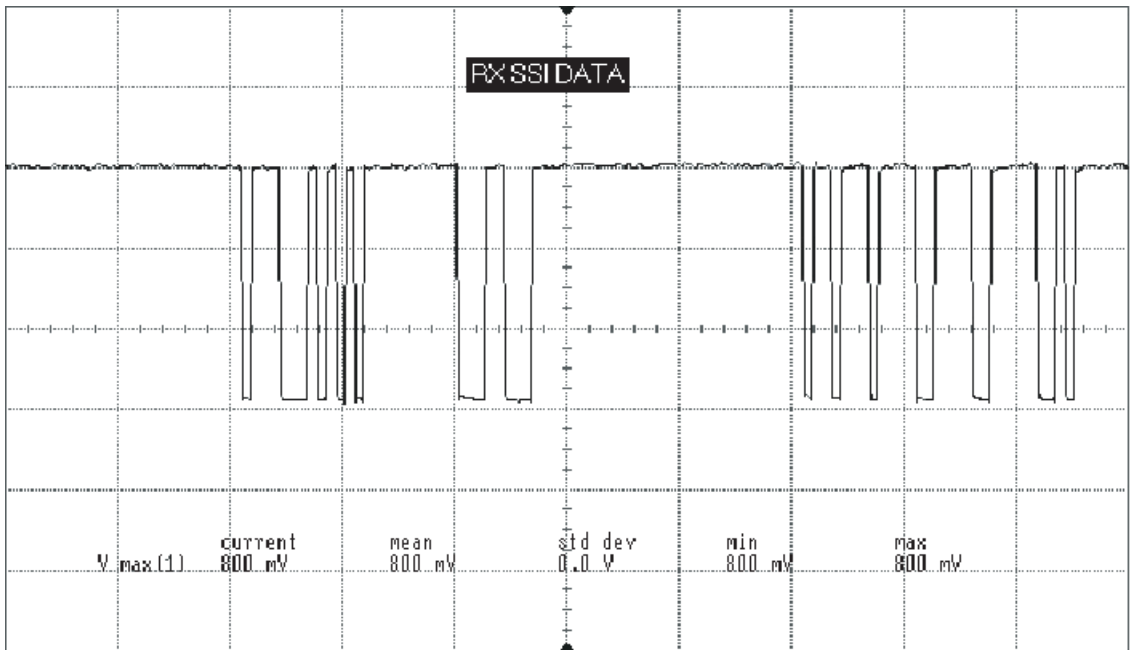

Test Point: SSI_D (Test Point).

7.3.44 TP38 RX SSI Clock

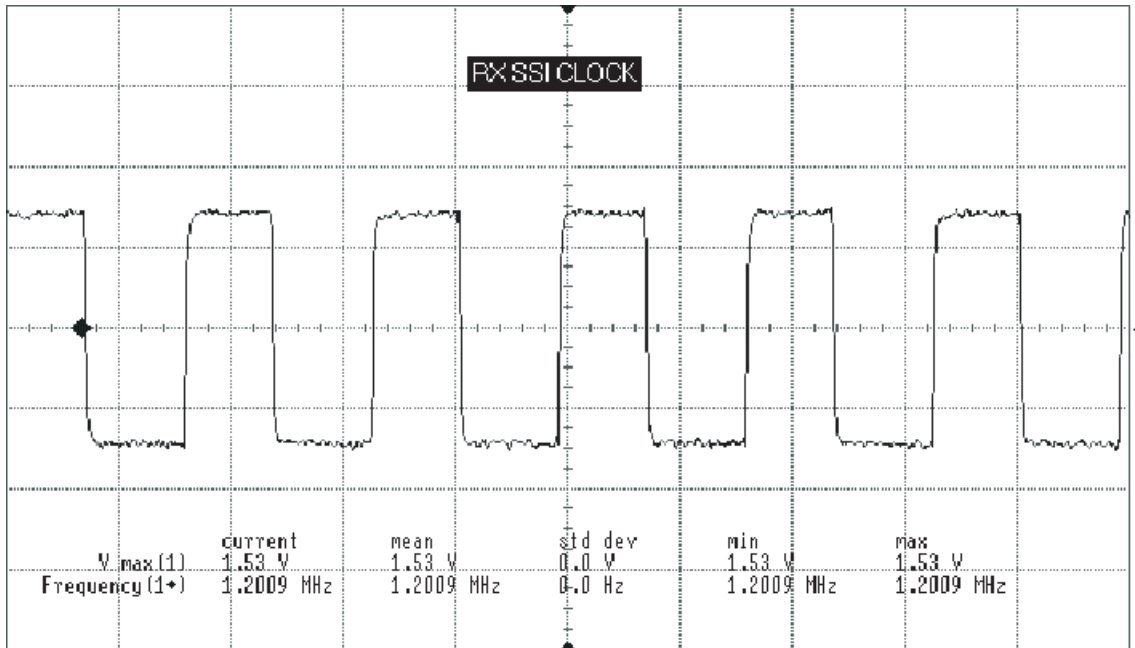

Test Point: SSI_CLK (Test Point).

7.3.45 TP39 RX SSI Frame Sync

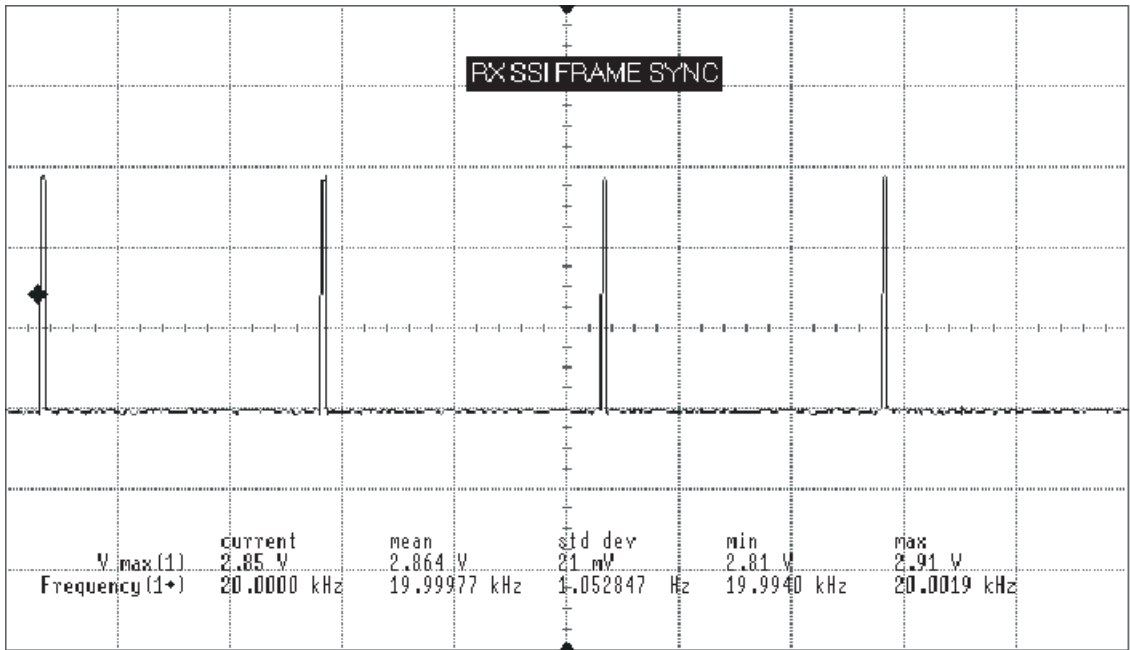

Test Point: SSI_FS (Test Point).

Test Point: TP401.

Chapter 7.4.4 700/800 MHz Troubleshooting Waveforms

7.4.1 Introduction

This chapter contains images of waveforms that might be useful in verifying operation of certain parts of the circuitry. These waveforms are for reference only; the actual data depicted will vary depending upon operating conditions. This manual is to be used in conjunction with the ASTRO XTS 2500 Digital Portable Radios Basic Service Manual (Motorola part number 68P81094C09), which uses the pass/fail service approach to radio problems.

7.4.2 List of Waveforms

[Table 7.4-1](#) lists each waveform and the page on which the waveform can be found.

Table 7.4-1. List of Waveforms

Waveform	Page No.	Waveform	Page No.
Antenna Input	7.4-6	Low-Noise Amplifier Output	7.4-29
TX Signal at Harmonic Filter Input	7.4-7	Preselector 2 Output	7.4-30
Coupler RF Out	7.4-8	Mixer Out (IF)	7.4-31
TX Signal at PA	7.4-9	Crystal Filter Out	7.4-32
Coupler RF Feedback to PCIC	7.4-10	Abacus Analog 3V	7.4-33
PCIC Control Voltage	7.4-11	2nd LO Control Voltage	7.4-34
TX LO	7.4-12	2nd LO VCO Buffer Output	7.4-35
Higher Level Voltage Multiplier	7.4-13	Abacus Digital 3V	7.4-37
Superfilter Output	7.4-14	TX Audio 1 kHz Tone	7.4-38
TRB	7.4-15	16.8 MHz Buffer Input and Output	7.4-39
Prescaler Input to FracN Synthesizer	7.4-16	32.768 kHz Clock Outputs	7.4-40
Reference Crystal Output	7.4-17	SPI B Data	7.4-41
Mod In	7.4-18	RX Serial Audio Port (SAP)	7.4-42
1st LO Control Voltage	7.4-19	SPI Data	7.4-43
VCO Output	7.4-20	SPI CLK	7.4-44
VCO RX LO	7.4-21	Universal Chip Select	7.4-45
Frequency Out (16.8 MHz)	7.4-22	Abacus Chip Select	7.4-46
RX RF Input at Antenna Switch	7.4-23	RX SSI Data	7.4-47
Antenna Switch Bias	7.4-24	RX SSI Clock	7.4-48
Preselector Tuning Voltage	7.4-25	RX SSI Frame Sync	7.4-49
RX RF Input after Antenna Switch	7.4-26	RX SSI Sync B	7.4-50
Analog 5V	7.4-27		
Preselector 1 Output	7.4-28		

7.4.3 RF Test Points

The following RF block diagram and accompanying table (Table 7.4-2) shows the location of key probe points (PP) and test points (TP) for the XTS 2500 radio.

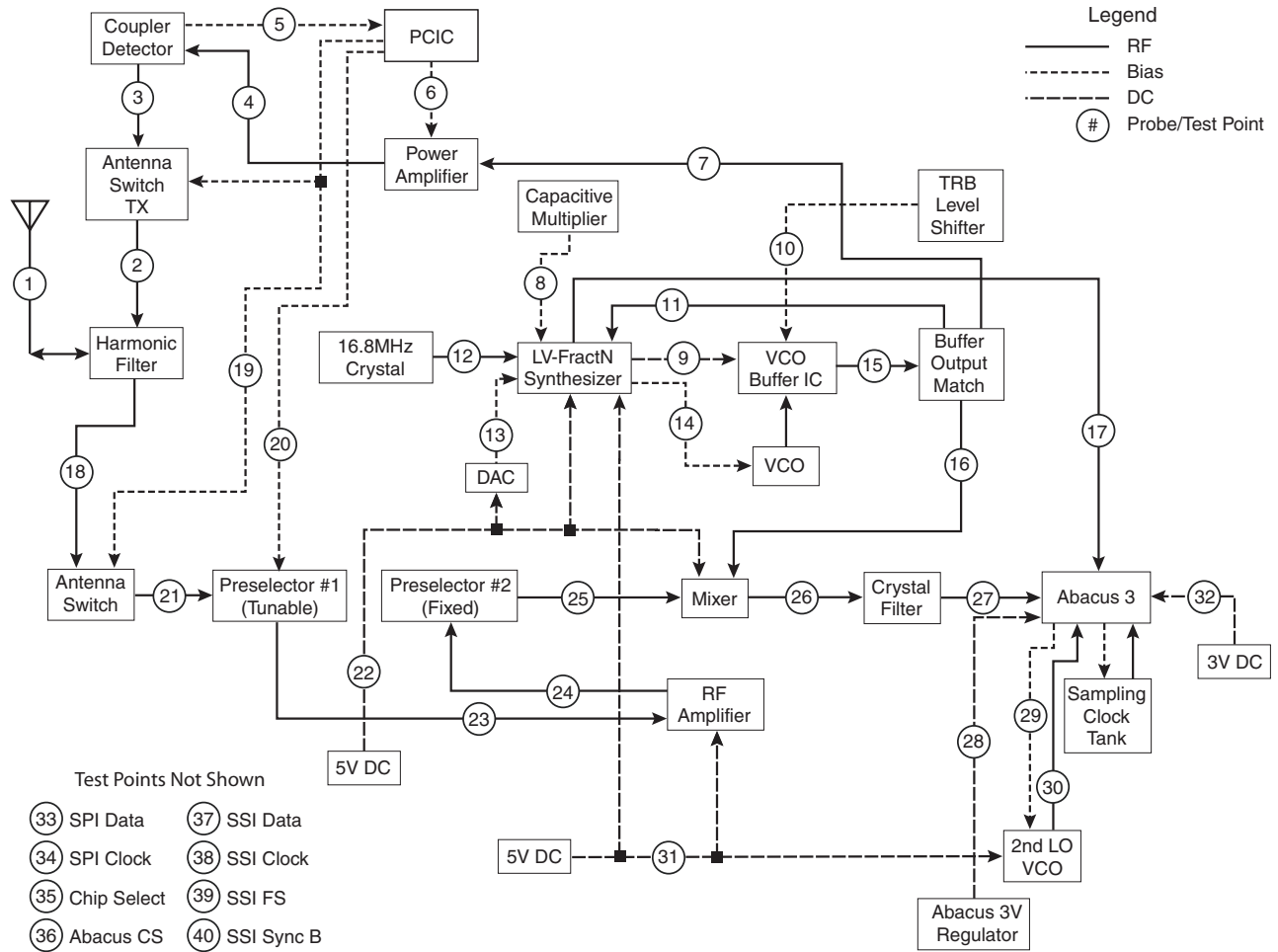

MAEPF-27353-O

Figure 7.4-1. RF Block Diagram Test Points

Table 7.4-2. RF Block Diagram Probe/Test Points

PP/TP	Name	Location	Under RF Shield?	Page
1	Antenna Input	J101, pin 5	No.	7.4-6
2	TX Signal at Harmonic Filter Input	C105	Yes.	7.4-7
3	Coupler RF Out	U103, pin 1	No.	7.4-8
4	TX Signal at PA	Q101, pin 2	No.	7.4-9
5	Coupler RF Feedback to PCIC	TP102	No.	7.4-10
6	PCIC Control Voltage	TP101	No.	7.4-11
7	TX LO	Tx_inj	No.	7.4-12
8	Higher Level Voltage Multiplier	C207	Yes.	7.4-13
9	Superfilter Output	C240	Yes.	7.4-14
10	TRB	TP001	No.	7.4-15
11	Prescaler Input to FracN Synthesizer	C236	Yes.	7.4-16
12	Reference Crystal Output	C243, C293	No.	7.4-17
13	Mod In	TP203	No.	7.4-18
14	1st LO Control Voltage	TP202	No.	7.4-19
15	VCO Output	*	Yes.	7.4-20
16	VCO RX LO	C261	Yes.	7.4-21
17	Frequency Out (16.8 MHz)	C293	No.	7.4-22
18	RX RF Input at Antenna Switch	FL1, pin 1	No.	7.4-23
19	Antenna Switch Bias	U103, pin 1	No.	7.4-24
20	Preselector Tuning Voltage	FL1, pin 3; FL2, pin 3	No.	7.4-25
21	RX RF Input after Antenna Switch	FL1, pin 1	No.	7.4-26
22	Analog 5V	U500, pin 5	No.	7.4-27
23	Preselector 1 Output	FL1, pin 2	No.	7.4-28
24	Low-Noise Amplifier Output	FL2, pin 1	No.	7.4-29
25	Preselector 2 Output	FL2, pin 2	No.	7.4-30
26	Mixer Out (IF)	U1, PIN ?	No.	7.4-31
27	Crystal Filter Out	FL3, PIN ?	No.	7.4-32
28	Abacus Analog 3V	U501, pin 5	No.	7.4-33
29	2nd LO Control Voltage	U401, pin 38	Yes.	7.4-34
30	2nd LO VCO Buffer Output	C407?	No.	7.4-35
31	Analog 5V	U500, pin 5	No.	7.4-36
32	Abacus Digital 3V	U502, pin 5	No.	7.4-37
33	SPI Data	R802	No.	7.4-43
34	SPI CLK	R803	No.	7.4-44
35	Universal Chip Select	U102, pin 29	Yes.	7.4-45

Table 7.4-2. RF Block Diagram Probe/Test Points (Continued)

PP/TP	Name	Location	Under RF Shield?	Page
36	Abacus Chip Select	U401, pin 25	Yes.	7.4-46
37	RX SSI Data	TP403	No.	7.4-47
38	RX SSI Clock	TP404	No.	7.4-48
39	RX SSI Frame Sync	TP402	No.	7.4-49
40	Rx SSI Sync B	TP401	No.	7.4-50

PP = Probe Point
TP = Test Point

* C261 for LO Output
C266 for TX Output
C236 for Preselector Output

Note: For test/probe points indicated with the SH prefix, use an HP 85024A High Frequency Probe to detect a signal. The probe should be placed in center of the hole located on the top of the shield. Make sure the probe does not touch the shield or any other components.

7.4.4 Main Circuit Board RF Shield Locations

Viewed from Side 1

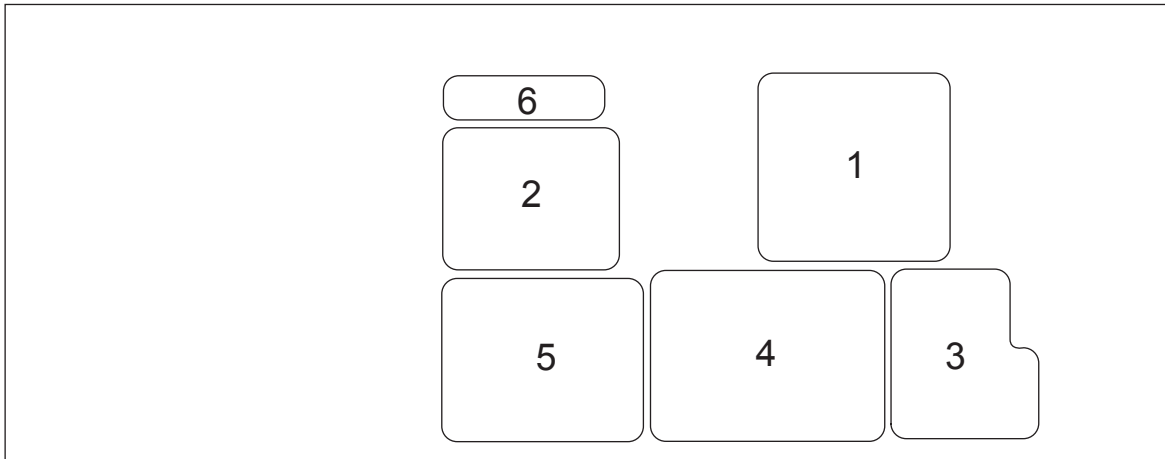

MAEPF-27489-O

Table 7.4-3. Main Circuit Board Side 1 RF Shields

Item Number	Reference Number	Motorola Part Number	Description
1	SH401	2685089D01	Shield, ABACUS
2	SH201	2685081D01	Shield, Synthesizer
3	SH103	2685083D01	Shield, Harmonic Top
4	SH104	2685085D01	Shield, PA
5	SH205	2685086D01	Shield, VCO Top
6	SH204	2685241D01	Shield, DAC

Viewed from Side 2

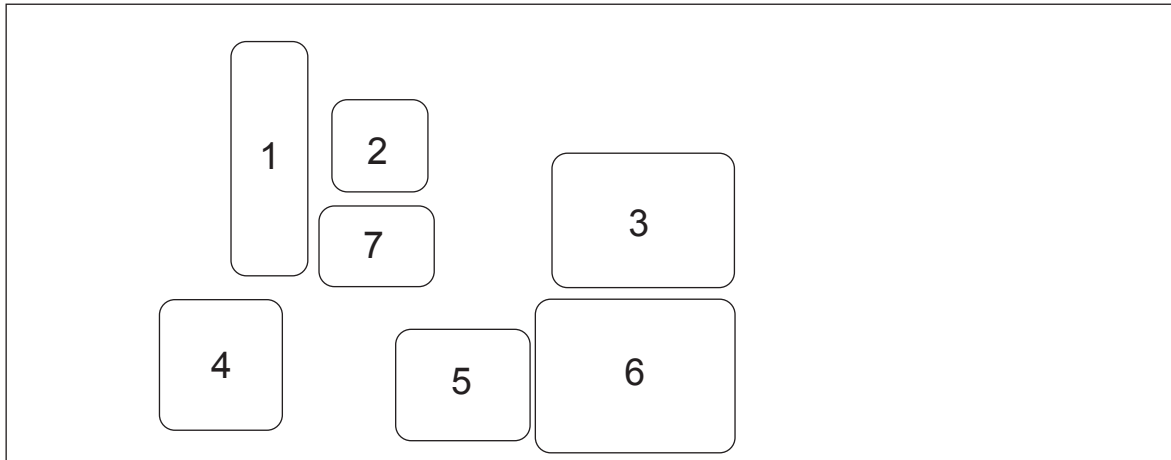

MAEPF-27488-O

Table 7.4-4. Main Circuit Board Side 2 RF Shields

Item Number	Reference Number	Motorola Part Number	Description
1	SH1	2685090D01	Shield, Mixer
2	SH402	2685080D01	Shield, 2nd LO
3	SH202	2685088D01	Shield, Frac-N
4	SH102	2685084D01	Shield, Harmonic Bottom
5	SH101	2685082D01	Shield, PCIC
6	SH203	2685087D01	Shield, VCO Bottom
7	SH2	2685242D01	Shield, Crystal IF

7.4.5 PP1 Antenna Input

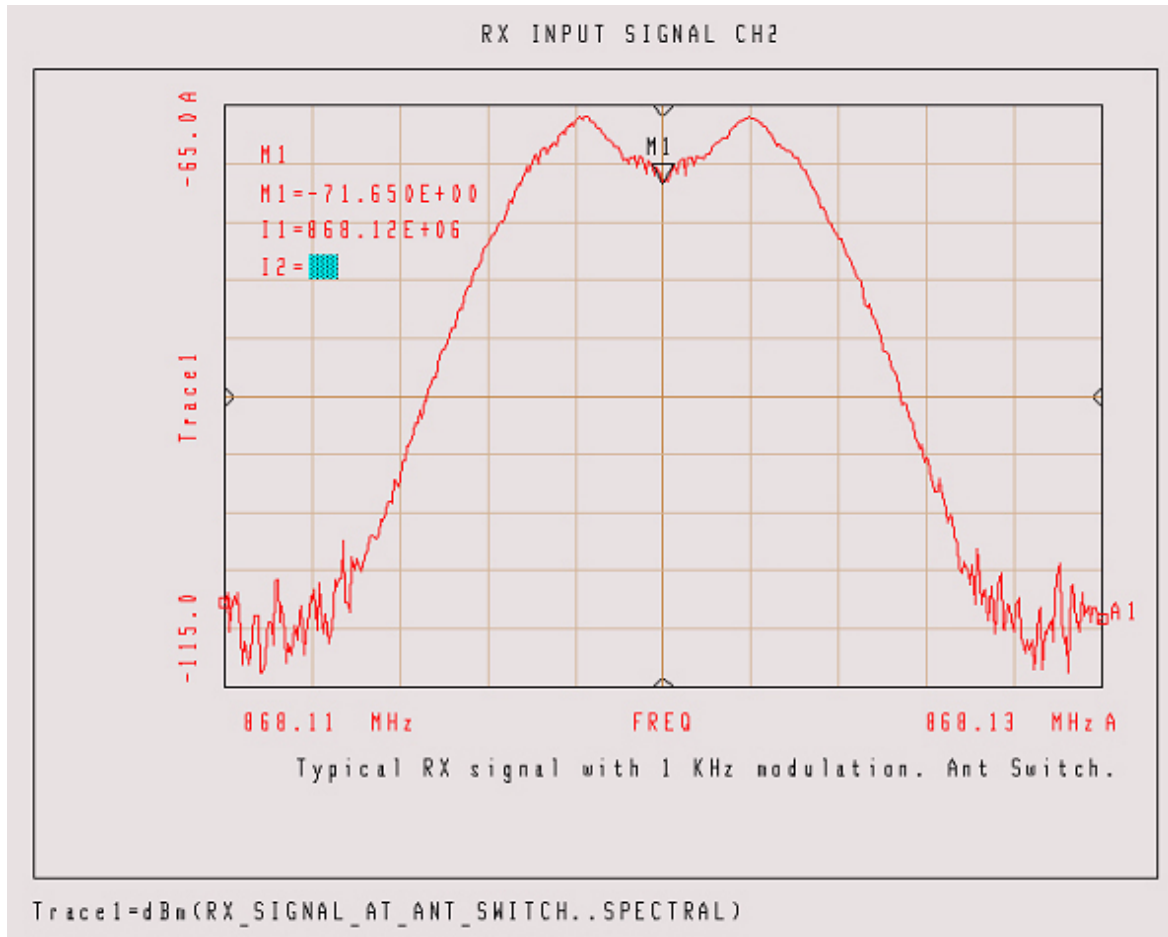

Probe point: J101, pin 5.

Typical RX signal with 1 kHz modulation. Display shows modulation components of carrier.

7.4.6 PP2 TX Signal at Harmonic Filter Input

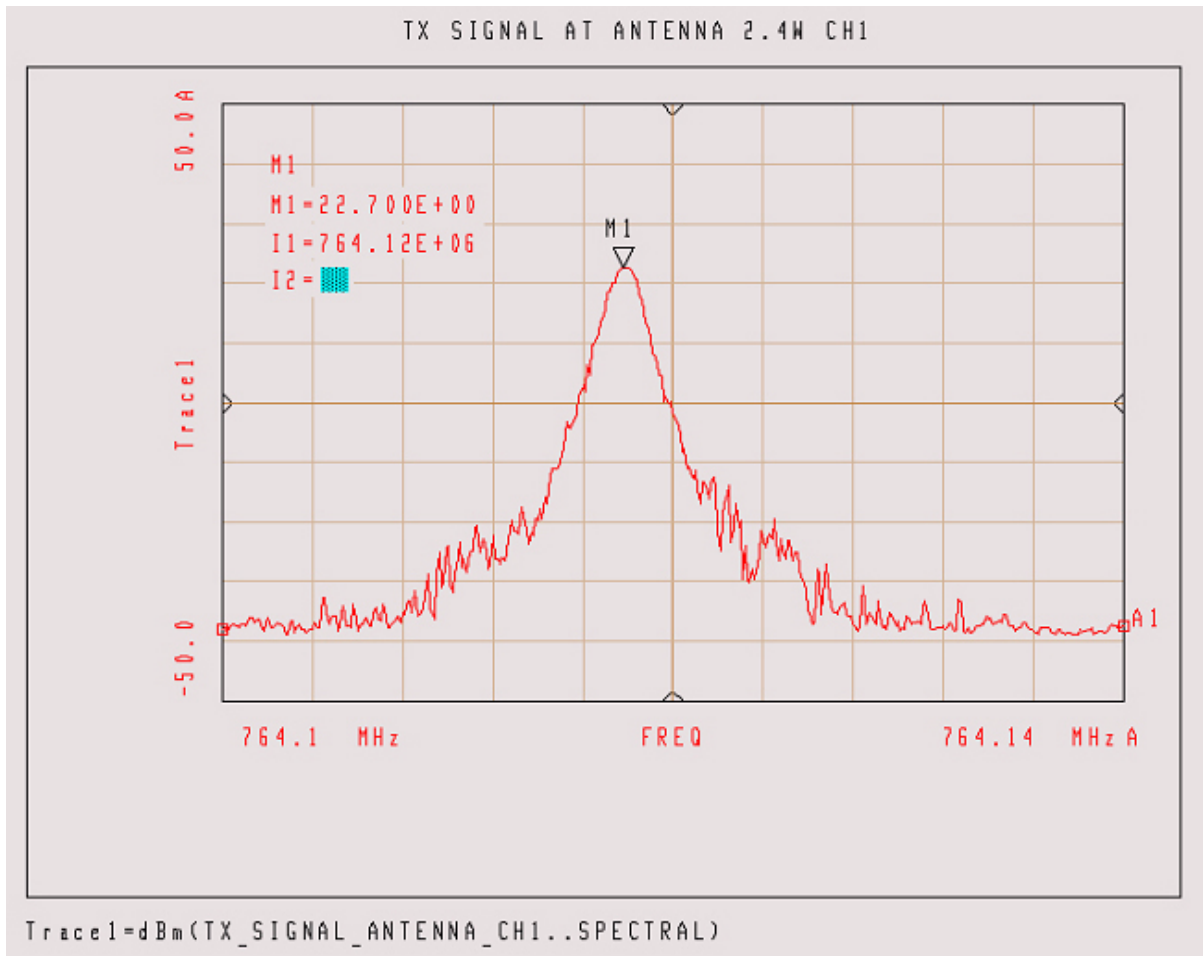

Probe point: C105 (located under shield).

7.4.7 PP3 Coupler RF Out

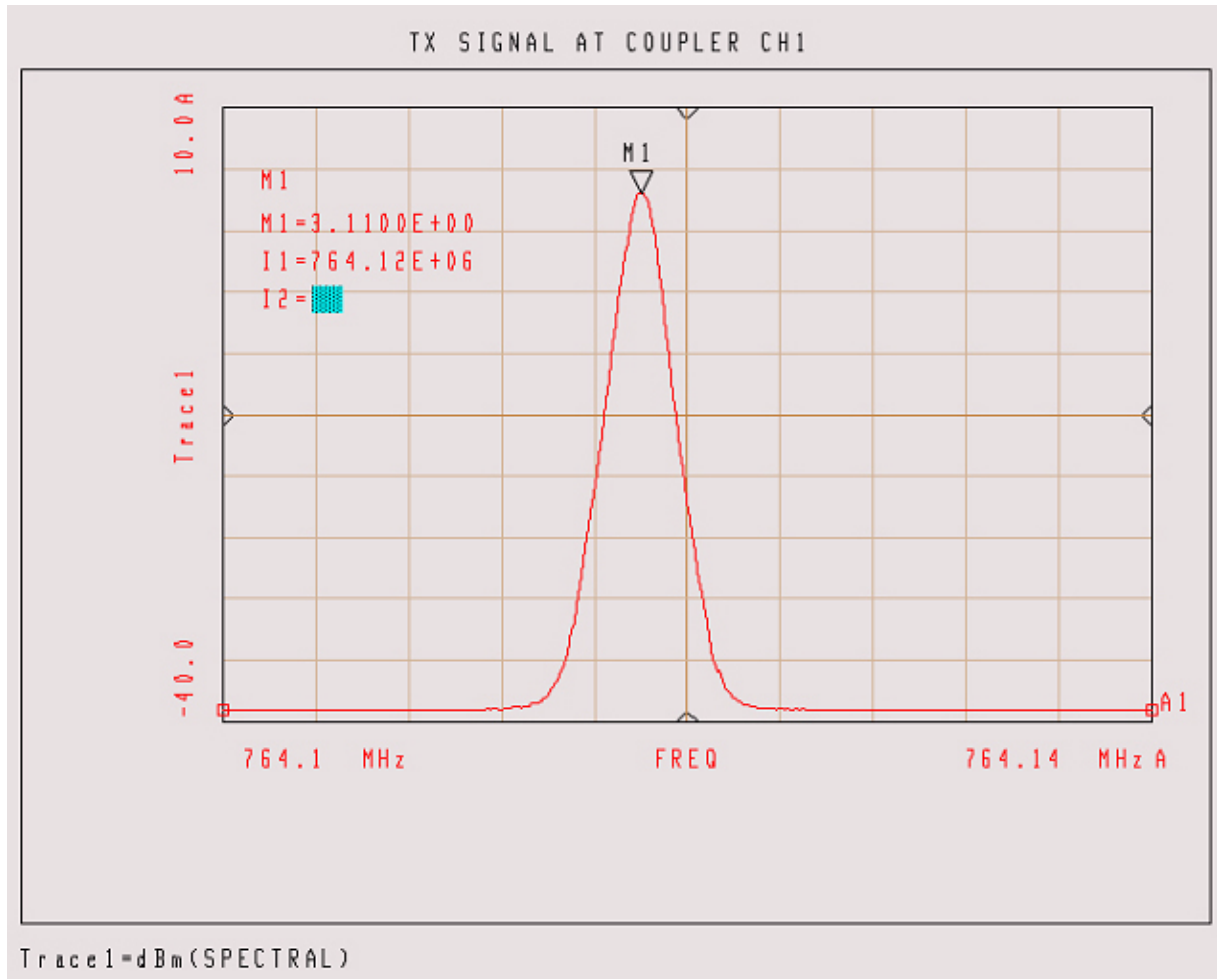

Probe point: U103, pin 1.

7.4.8 PP4 TX Signal at PA

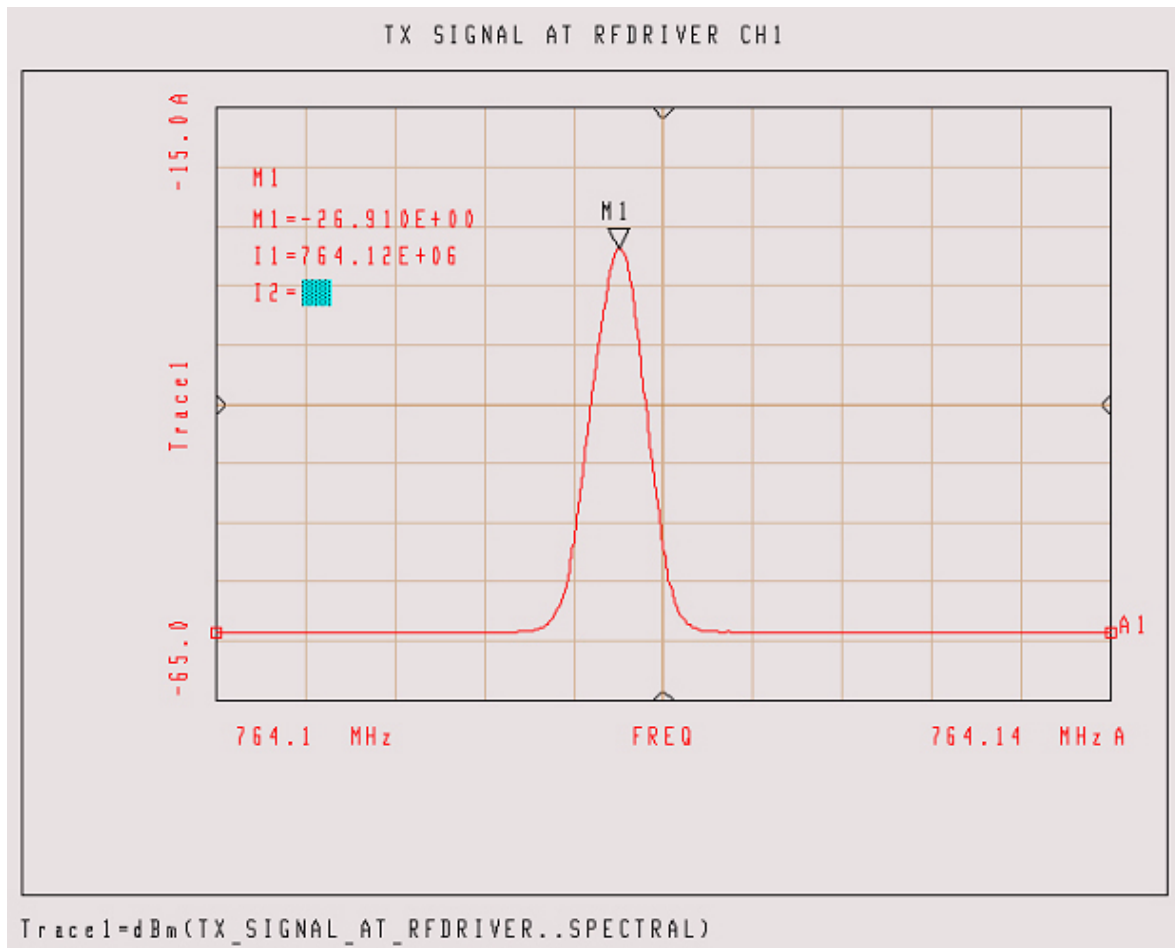

Probe point: Q101, pin 2.

7.4.9 TP5 Coupler RF Feedback to PCIC

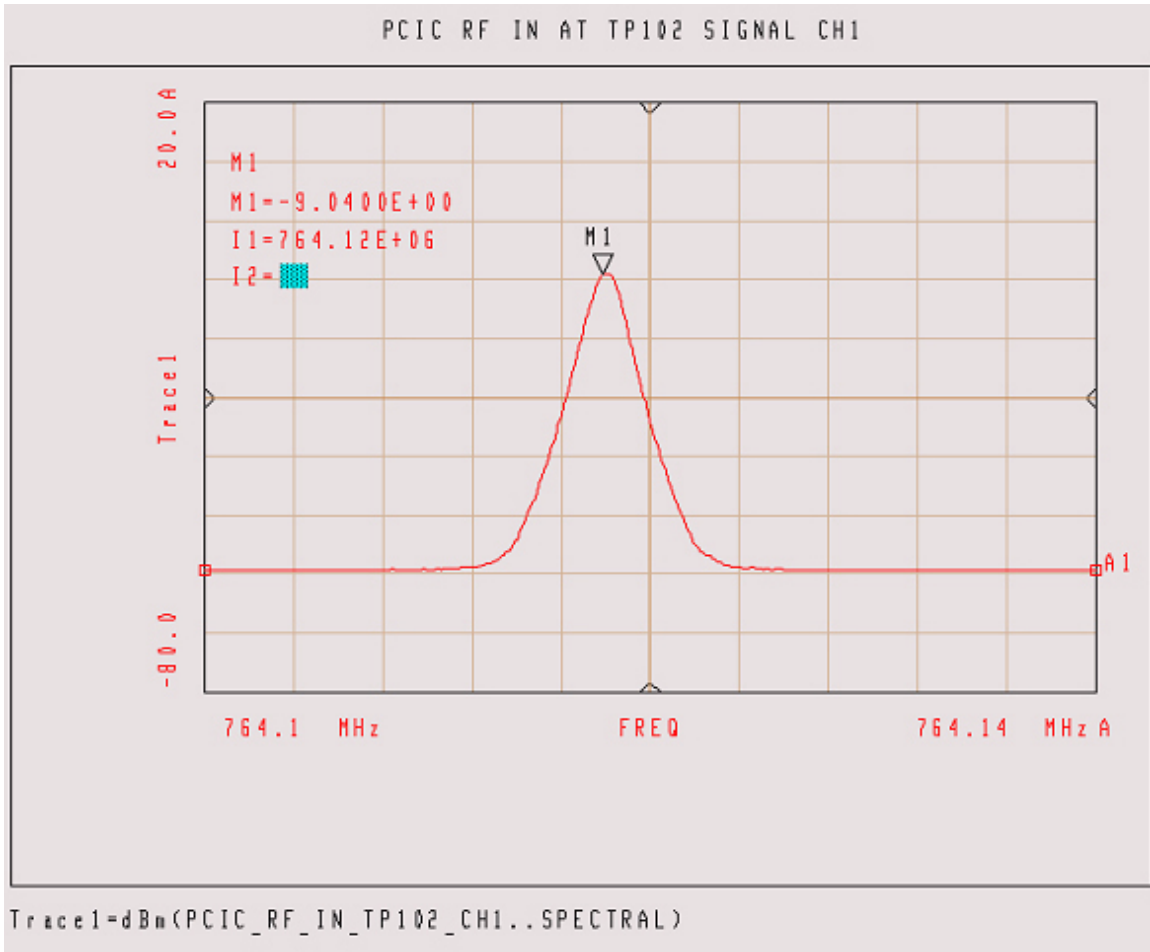

Test point: TP102.

7.4.10 TP6 PCIC Control Voltage

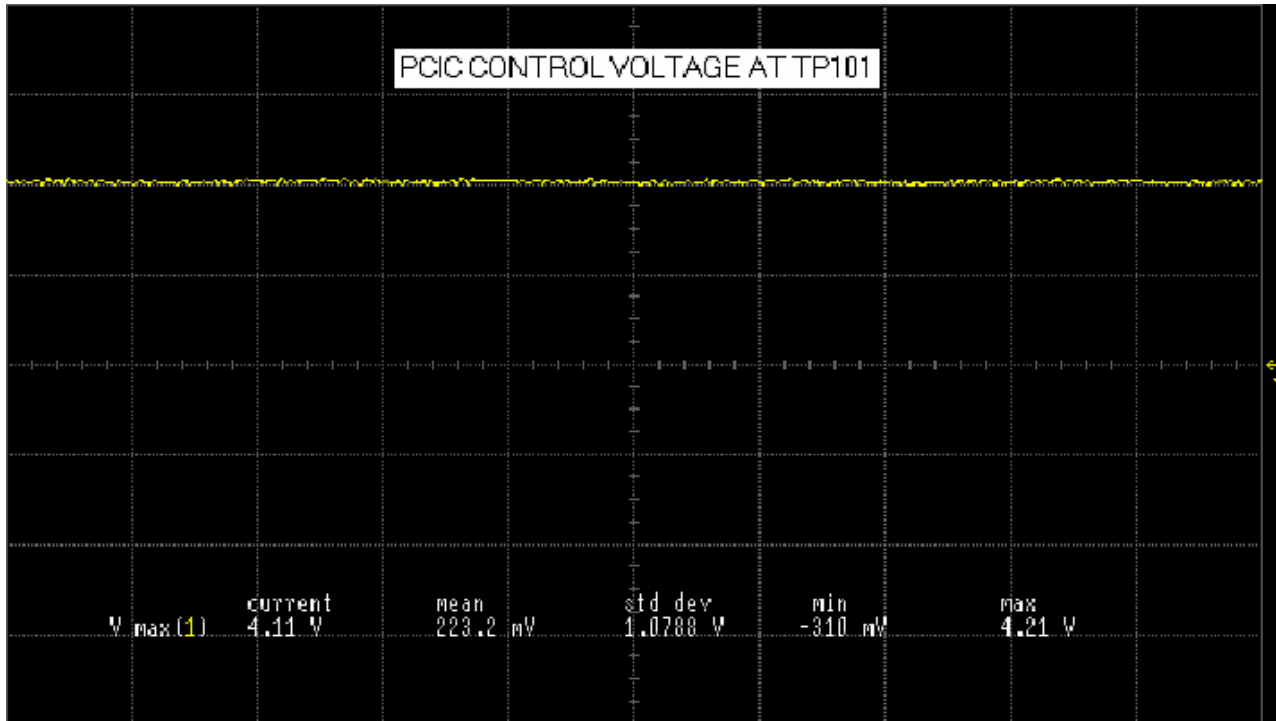

Test point: TP101.

7.4.11 PP7 TX LO

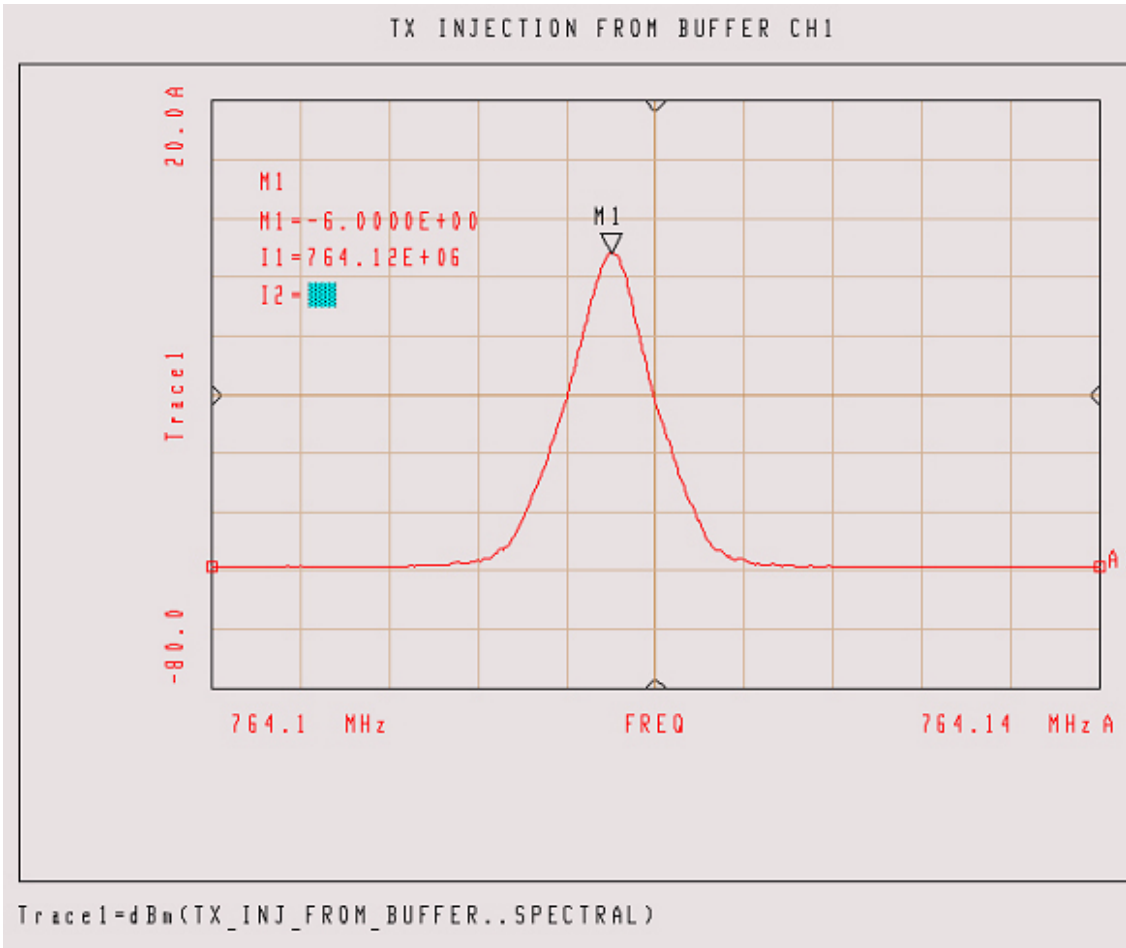

Probe point: Shield Tx_INJ.

7.4.12 PP8 Higher Level Voltage Multiplier

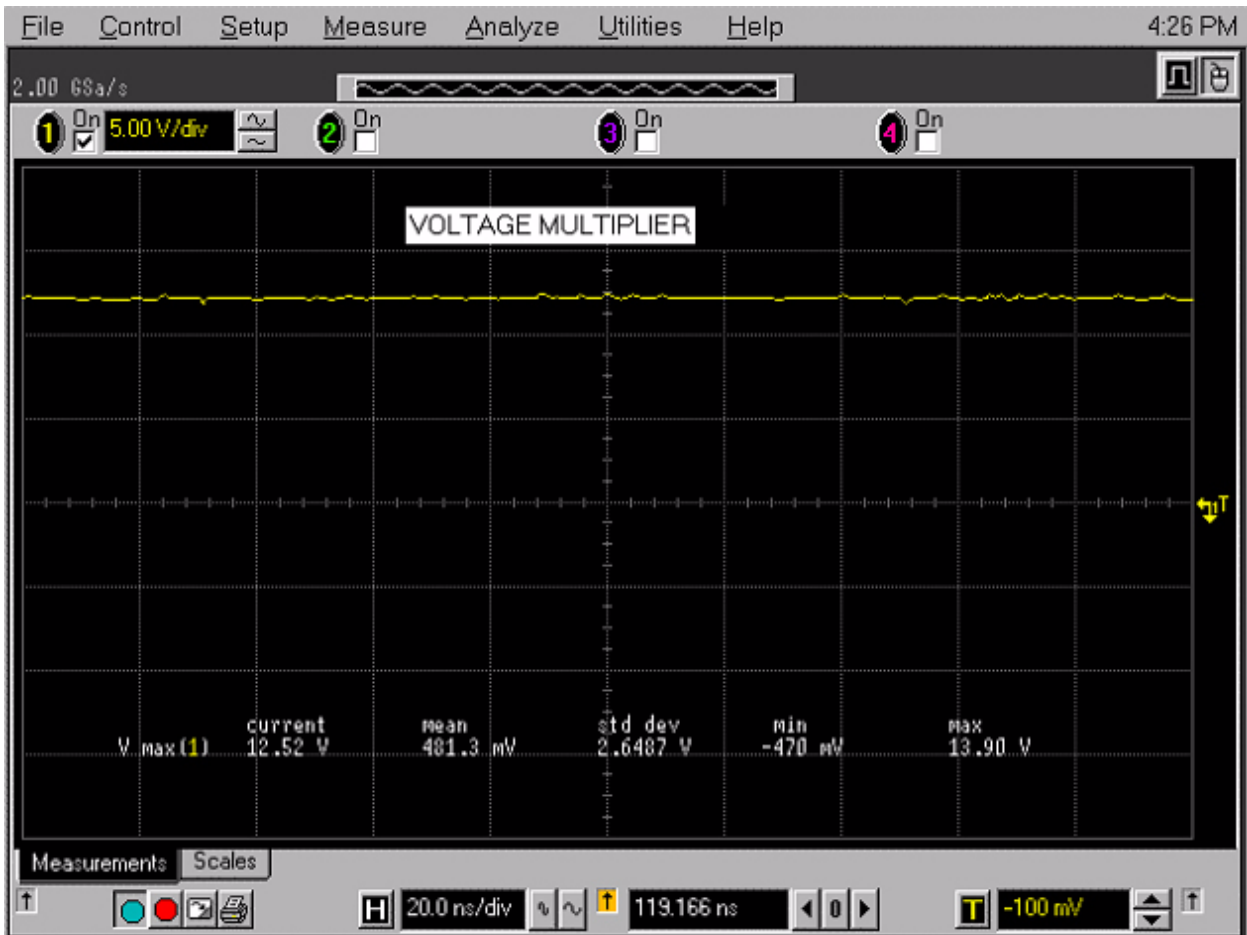

Probe point: C207 (located under shield).

7.4.13 PP9 Superfilter Output

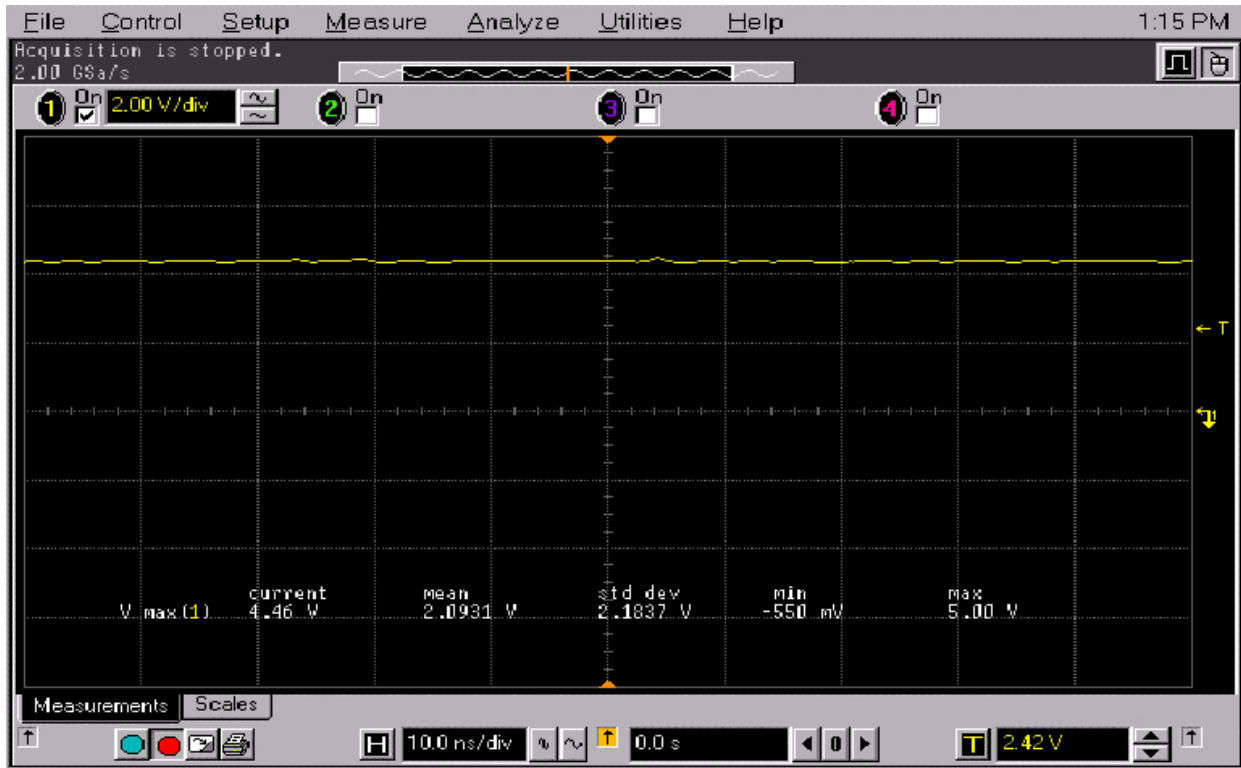

Probe point: C240 (located under shield).

7.4.14 TP10 TRB

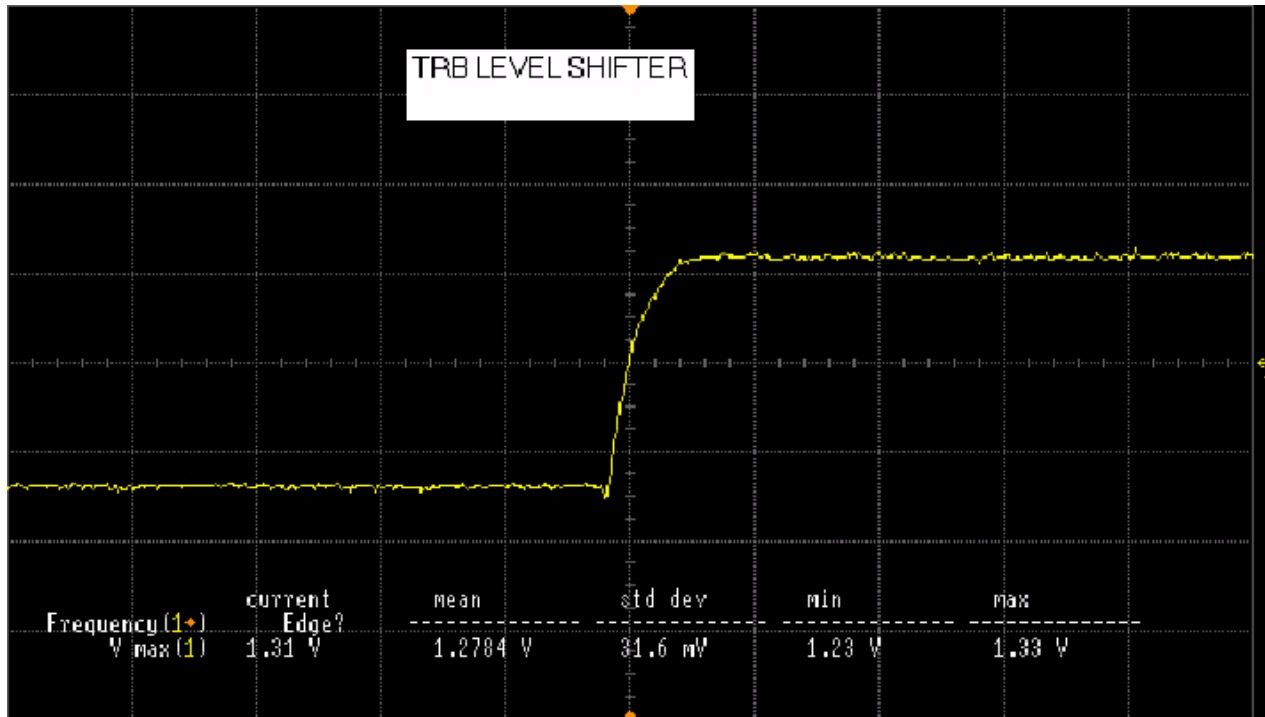

Test point: TP001.

Signal shows transition between RX mode (low) and TX mode (high).

7.4.15 PP11 Prescaler Input to FracN Synthesizer

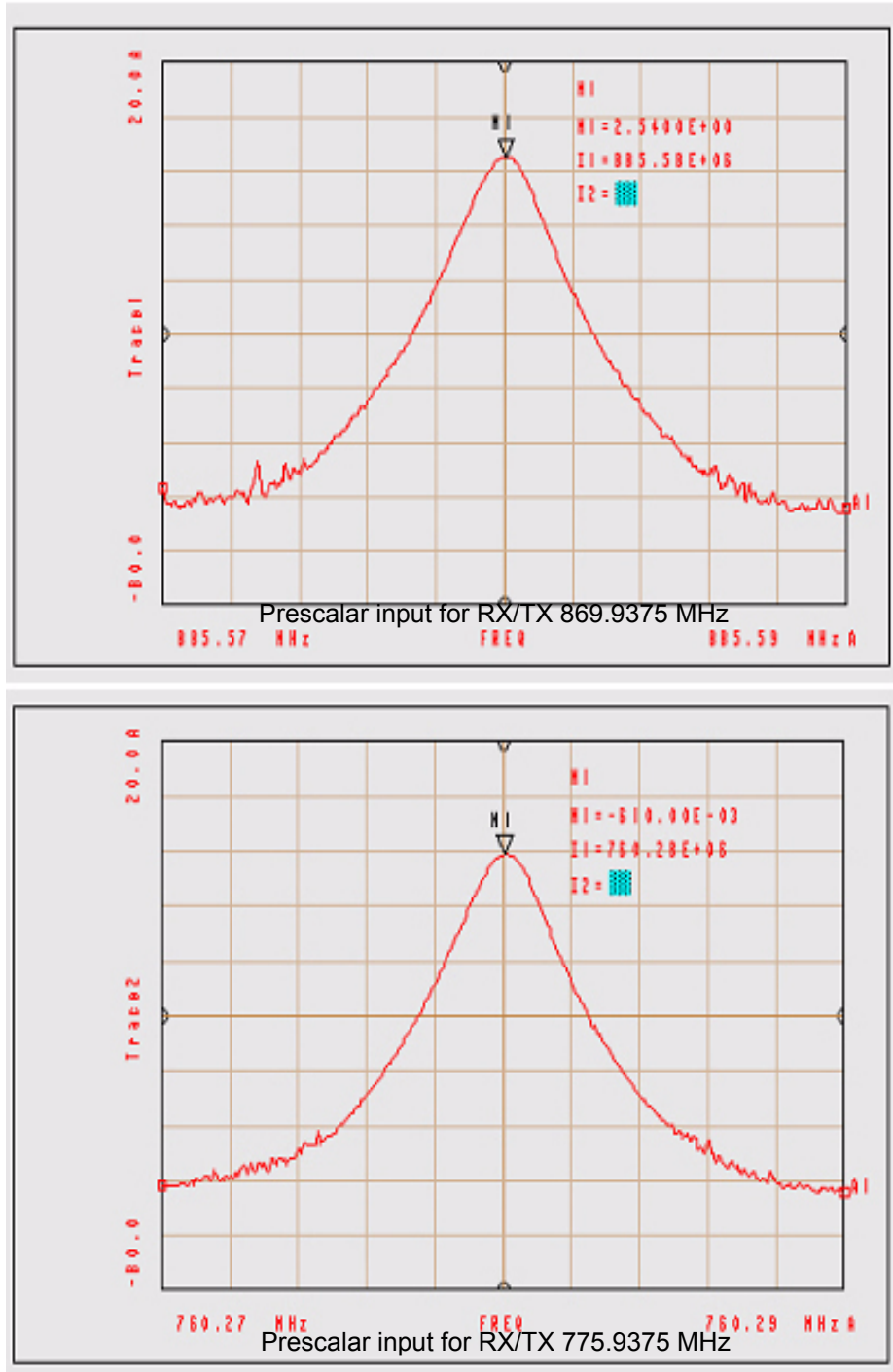

Probe point: C236 (located under shield).

7.4.16 PP12 Reference Crystal Output

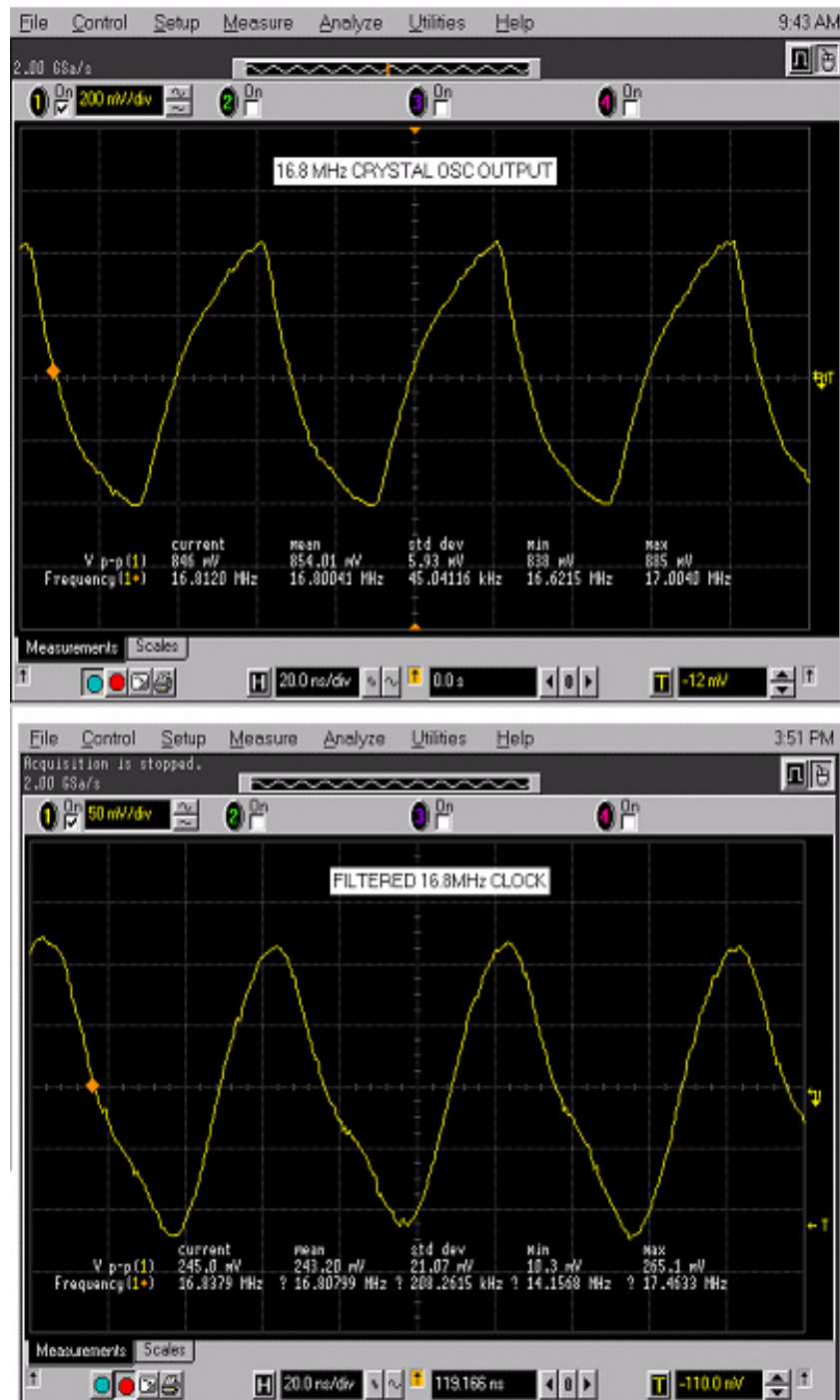

Probe point: R243, C293.

Crystal output AC coupled. Peak-to-peak value is accurate.

7.4.17 TP13 Mod In

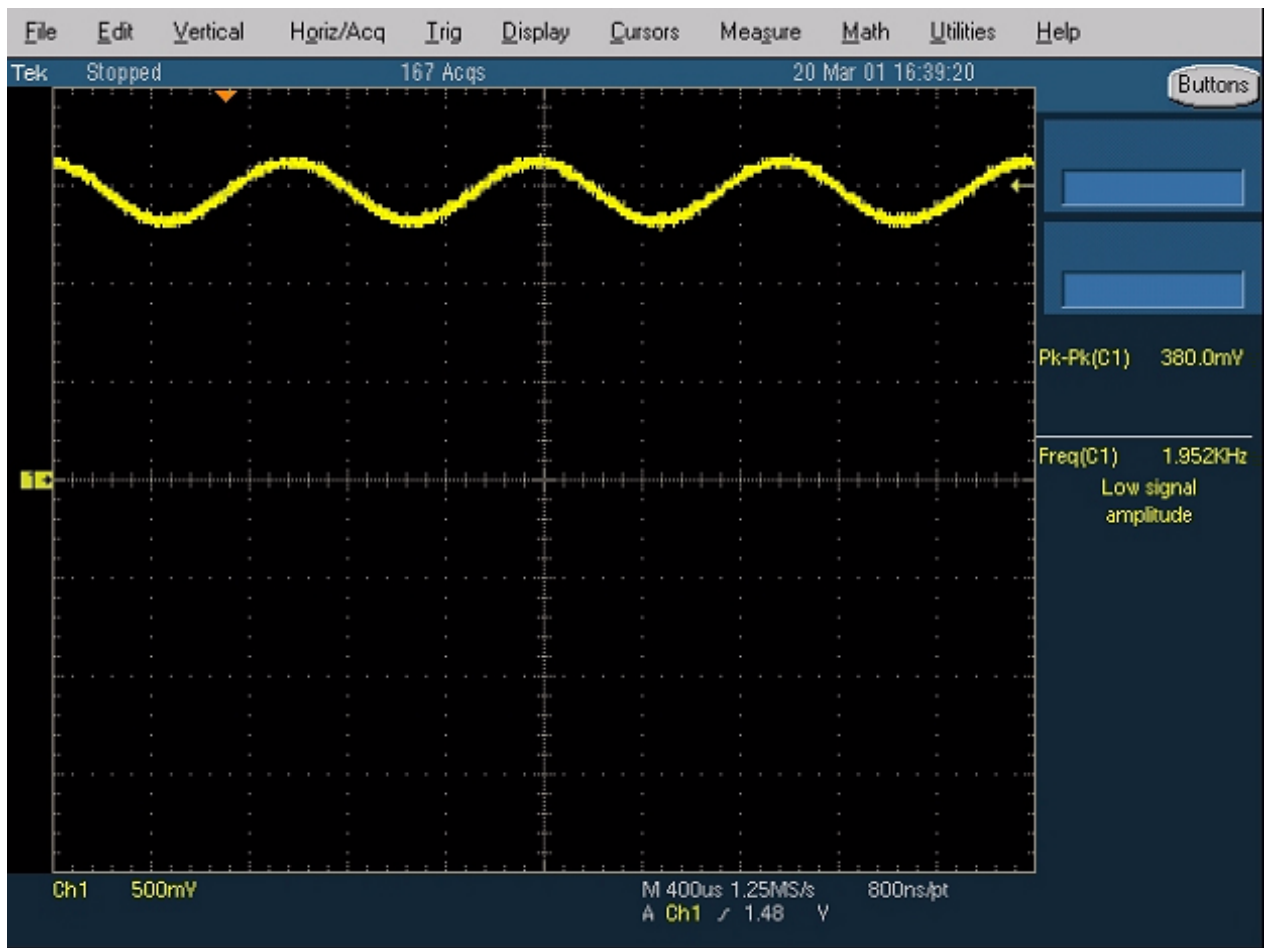

Test point: TP203.

7.4.18 TP14 1st LO Control Voltage

Typical value when tuned to receive at 758.475 MHz.

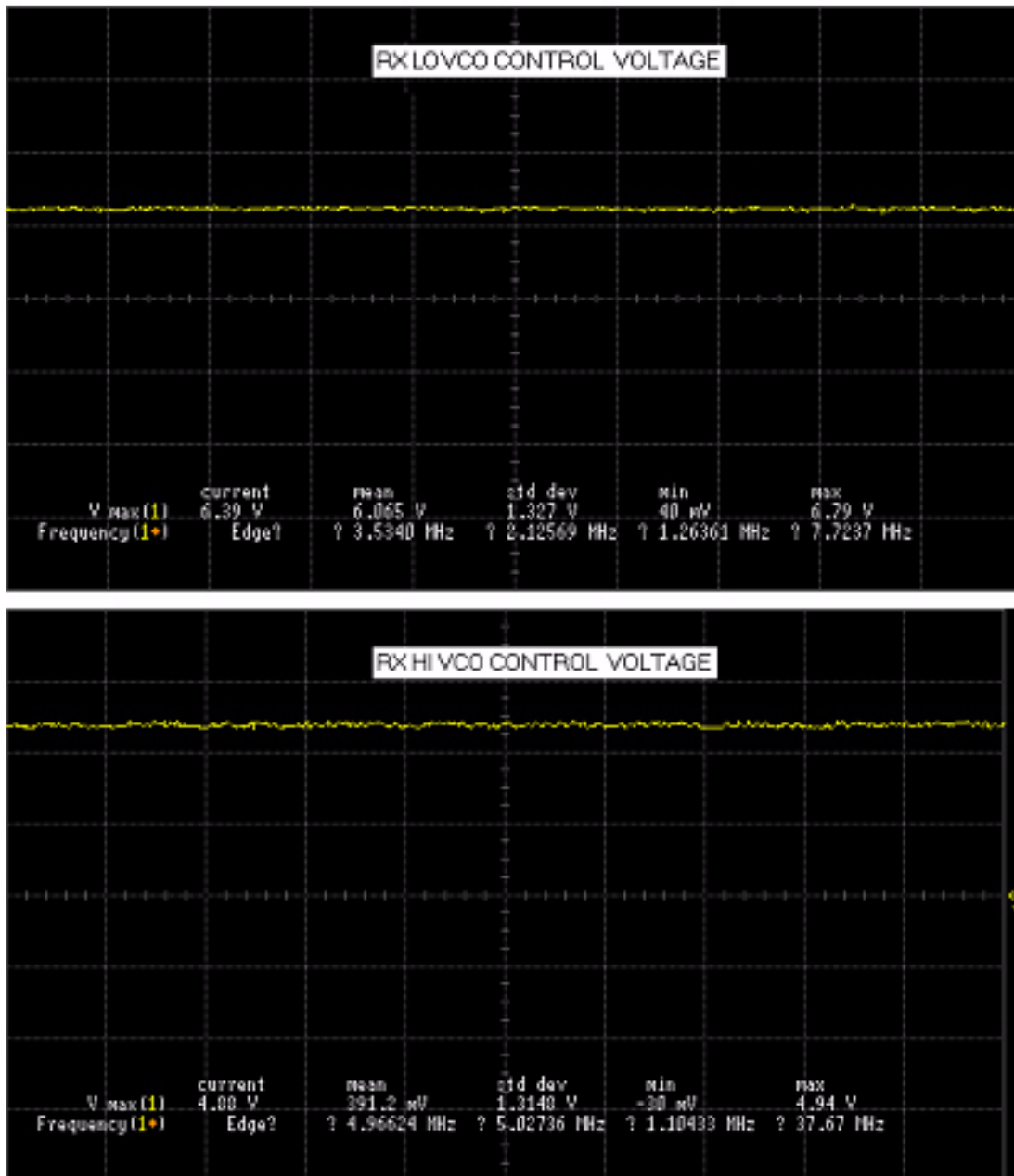

Typical value when tuned to receive at 873.775 MHz.

Test point TP202

7.4.19 PP15 VCO Output

RX VCO LOW Injection

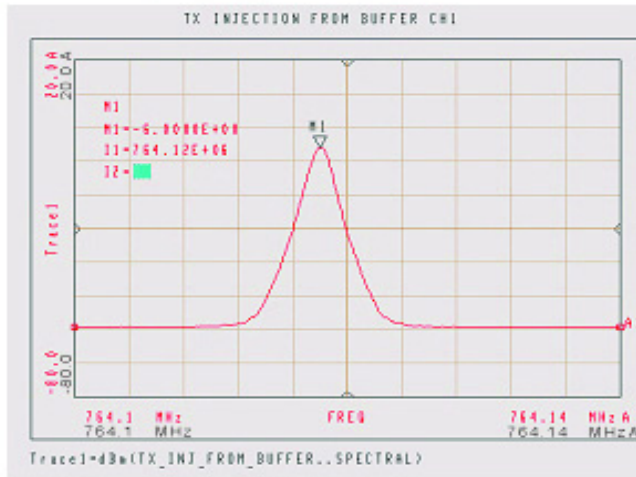
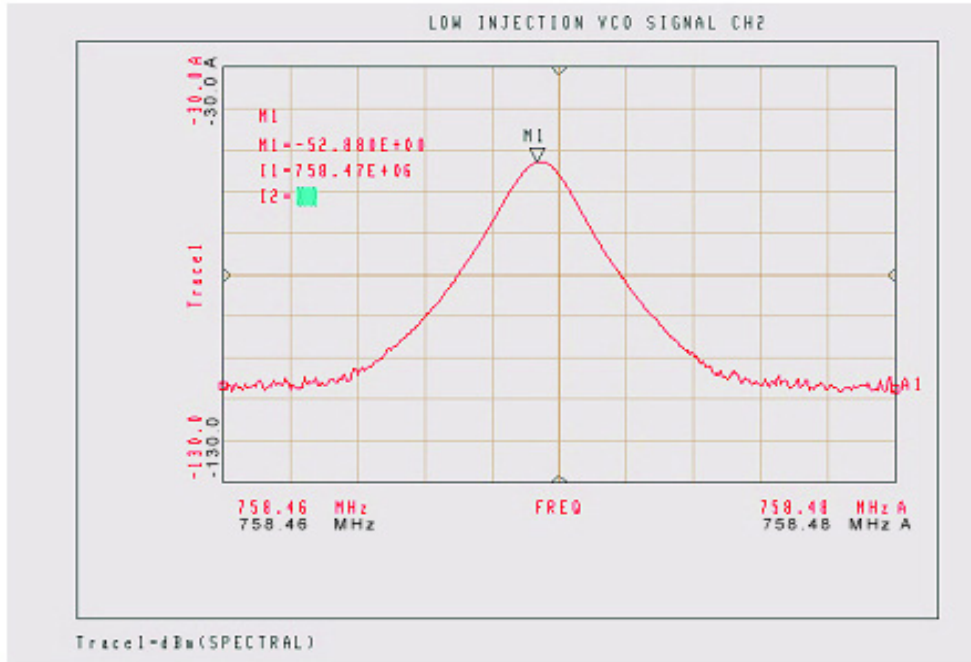

TX VCO

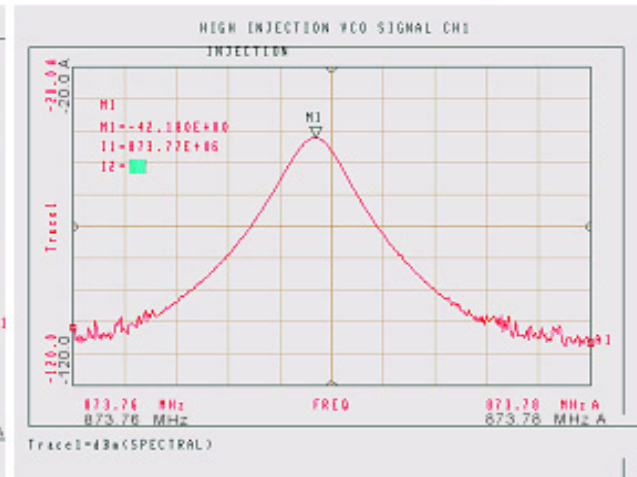

RX VCO HIGH Injection

Probe point: C261 for LO Output (located under shield)
 C266 for TX Output (located under shield)
 C236 for Preselector Output (located under shield).

7.4.20 PP16 VCO RX LO

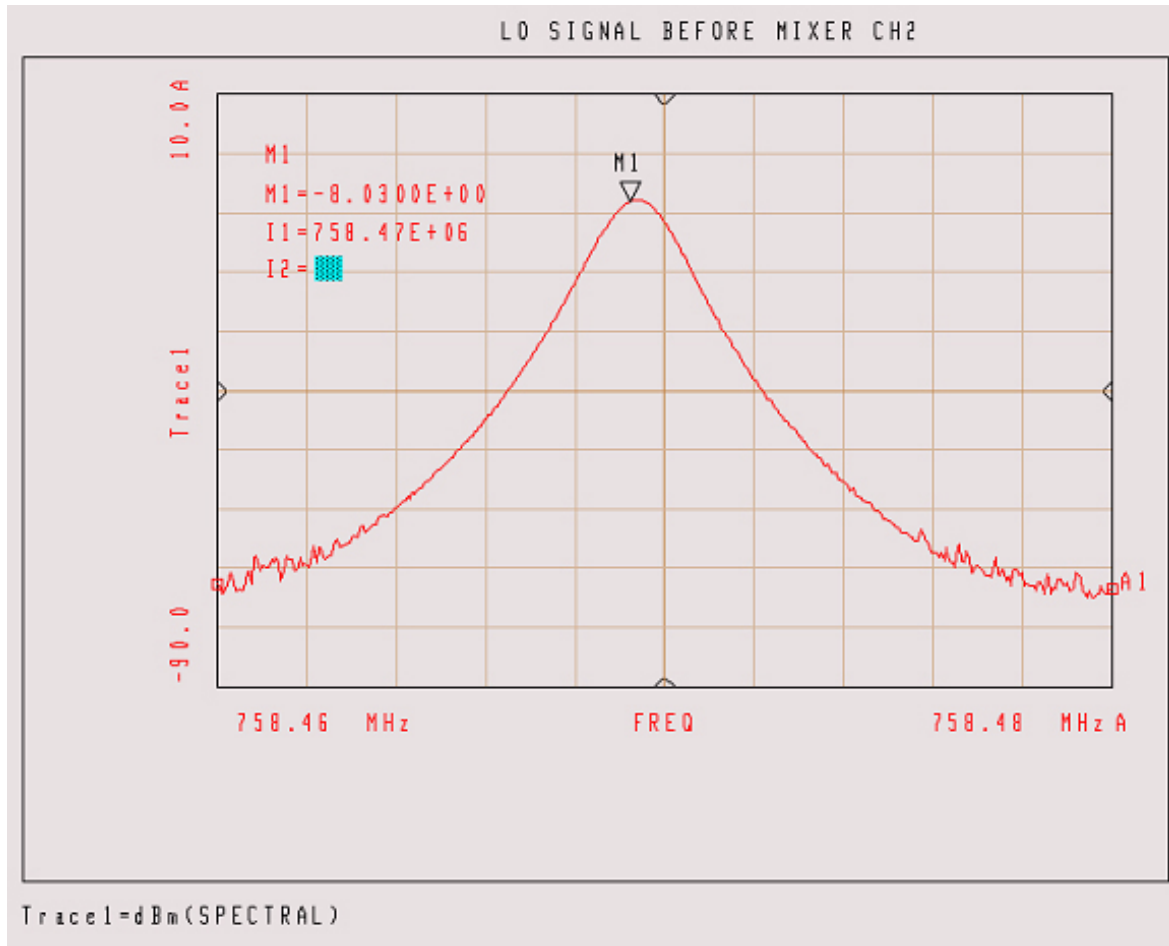

Probe point: C261 (located under shield).

7.4.21 PP17 Frequency Out (16.8 MHz)

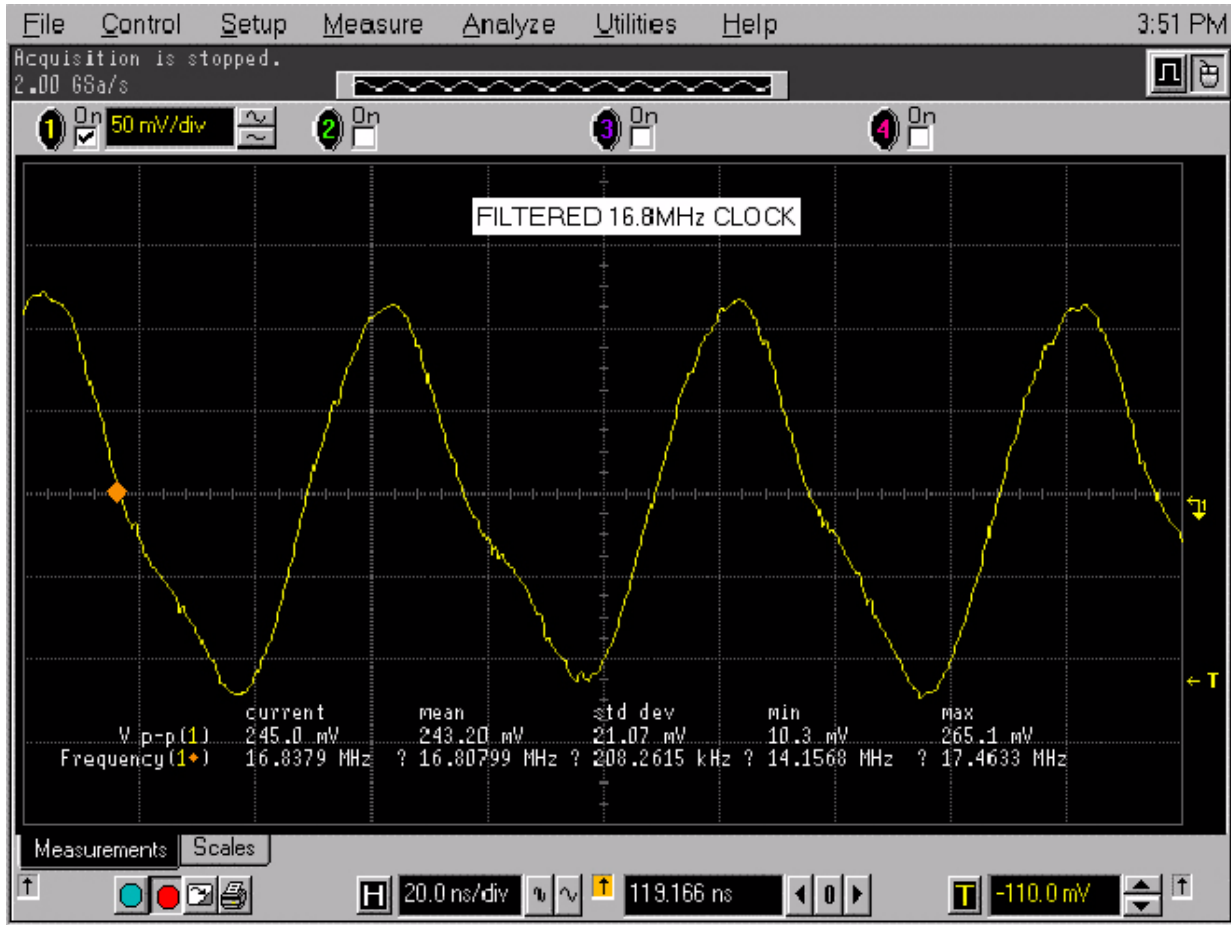

Probe point: Shield C293.

7.4.22 PP18 RX RF Input at Antenna Switch

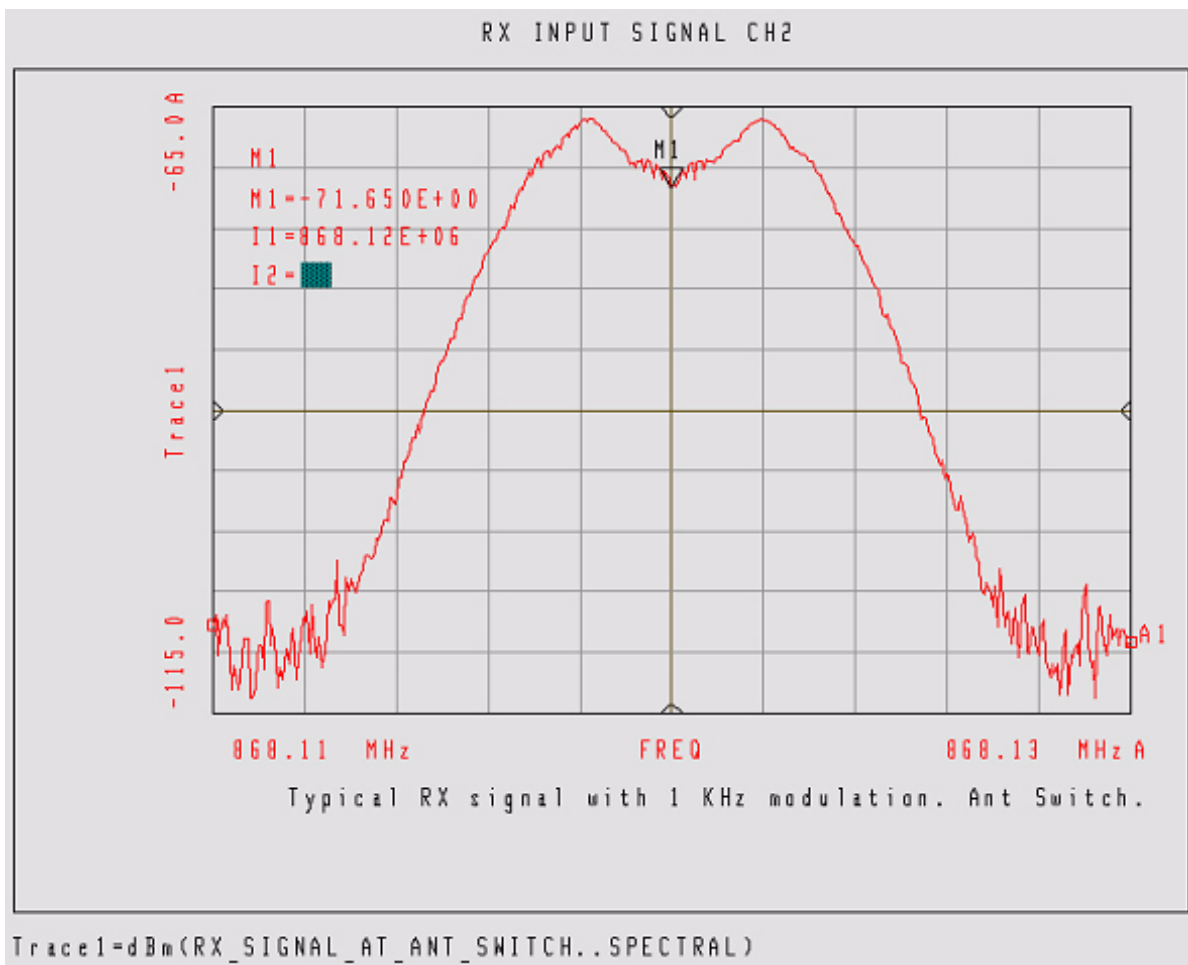

Probe point: FL1, pin 1.

Typical RX signal with 1 kHz modulation. Display shows modulation components of carrier.

7.4.23 PP19 Antenna Switch Bias

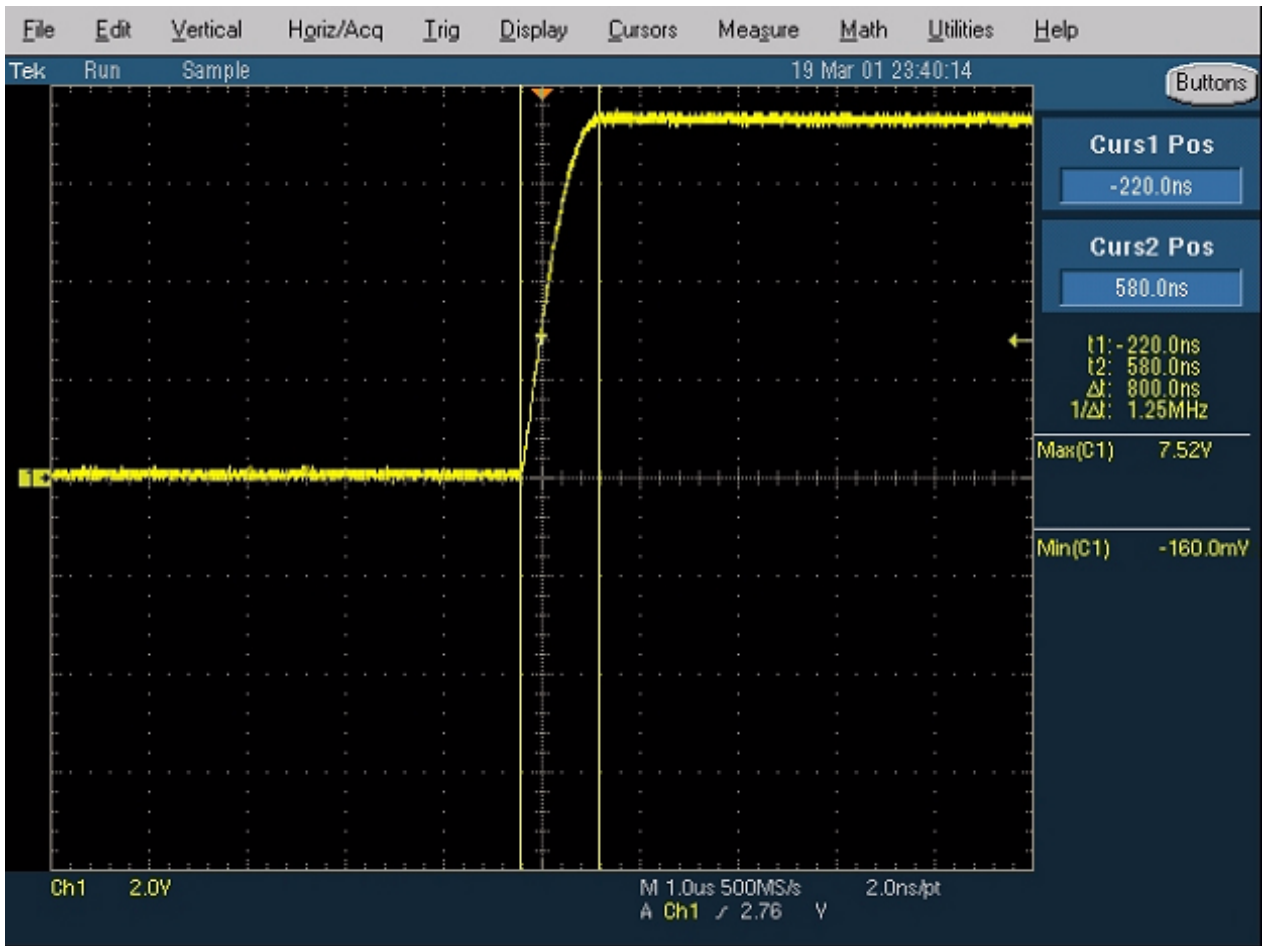

Probe point: U103, pin 1.

Display shows transition between RX mode (low) and TX mode (high).

7.4.24 PP20 Preselector Tuning Voltage

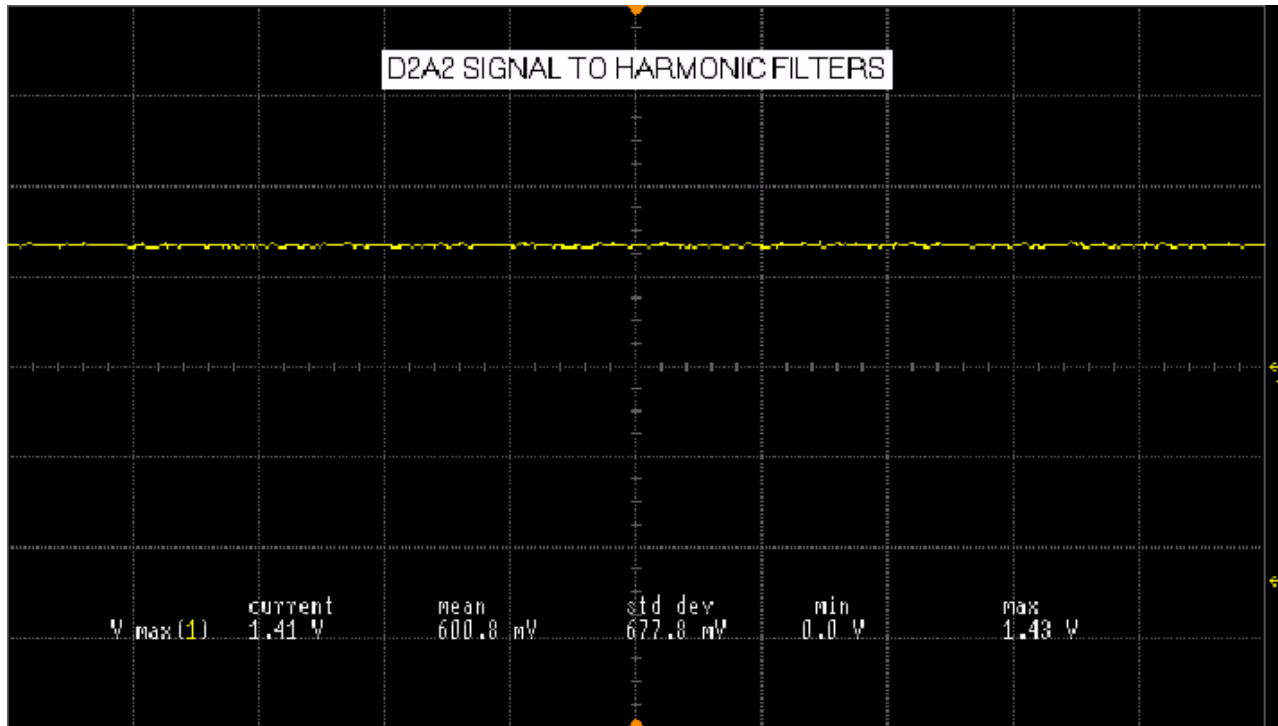

Probe point: FL1, pin 3; FL2, pin 3.

This is a typical value when tuned to receive at 764.125 MHz.

7.4.25 PP21 RX RF Input after Antenna Switch

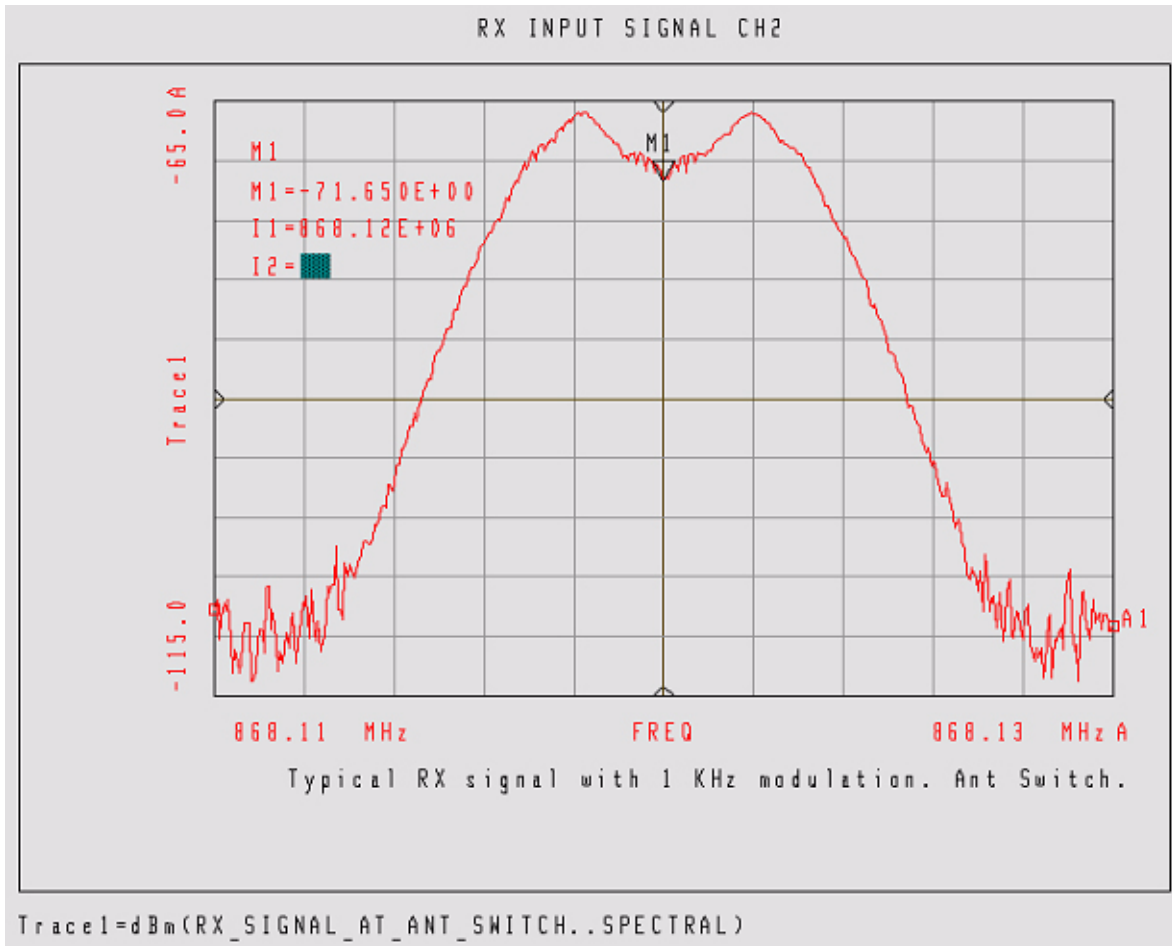

Probe point: FL1, pin 1.

7.4.26 PP22 Analog 5V

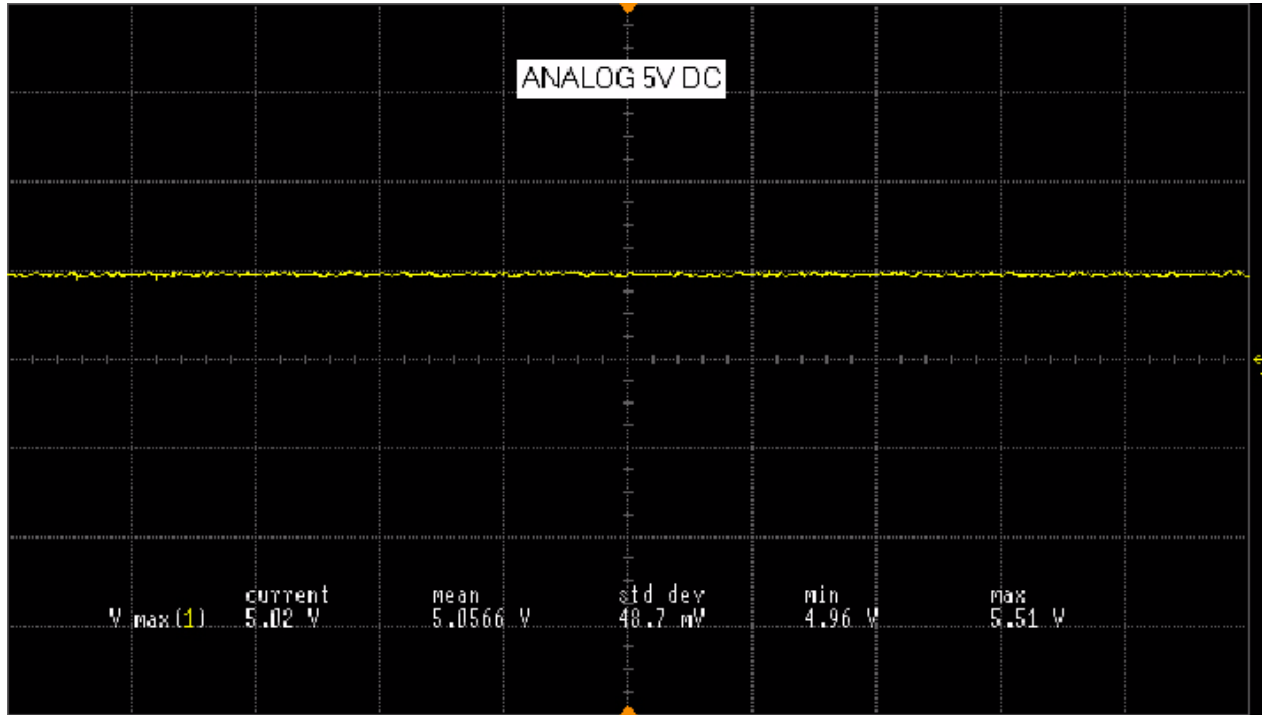

Probe point: U500, pin 5.

7.4.27 PP23 Preselector 1 Output

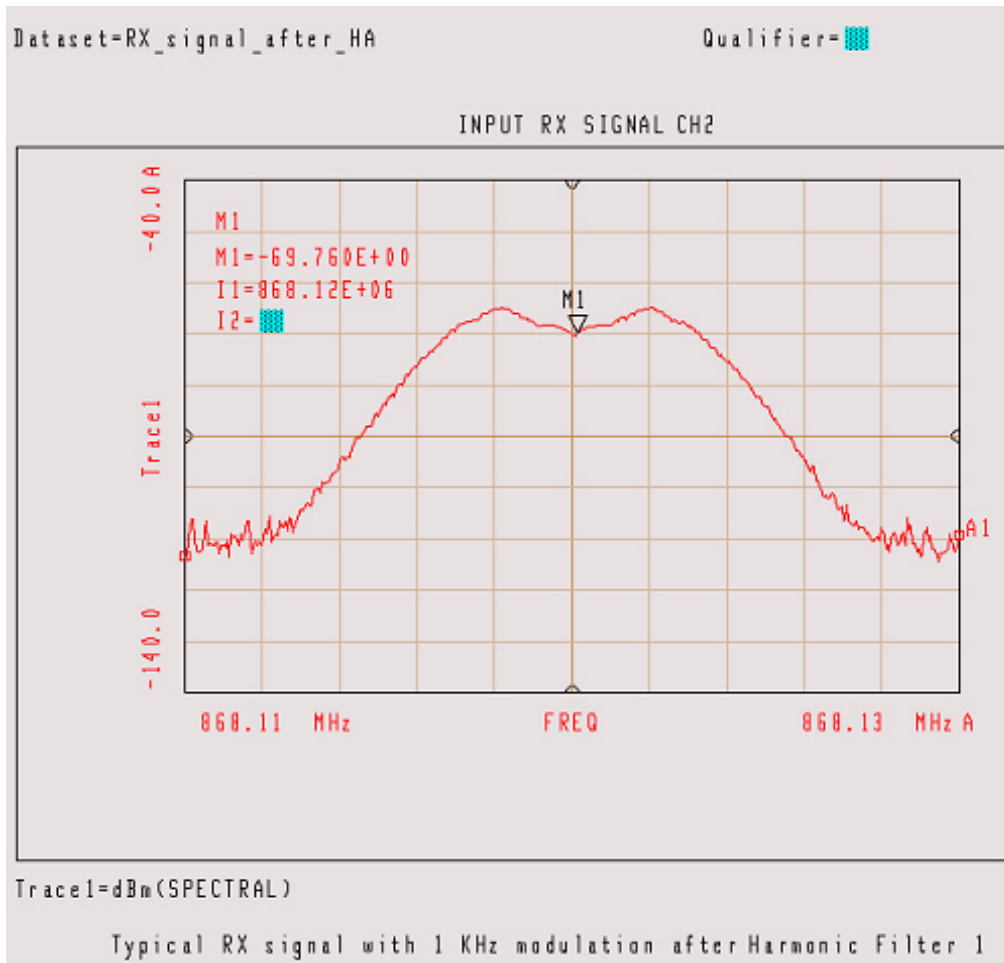

Probe point: FL1, pin 2.

Typical RX signal with 1 kHz modulation. Display shows modulation components of carrier.

7.4.28 PP24 Low-Noise Amplifier Output

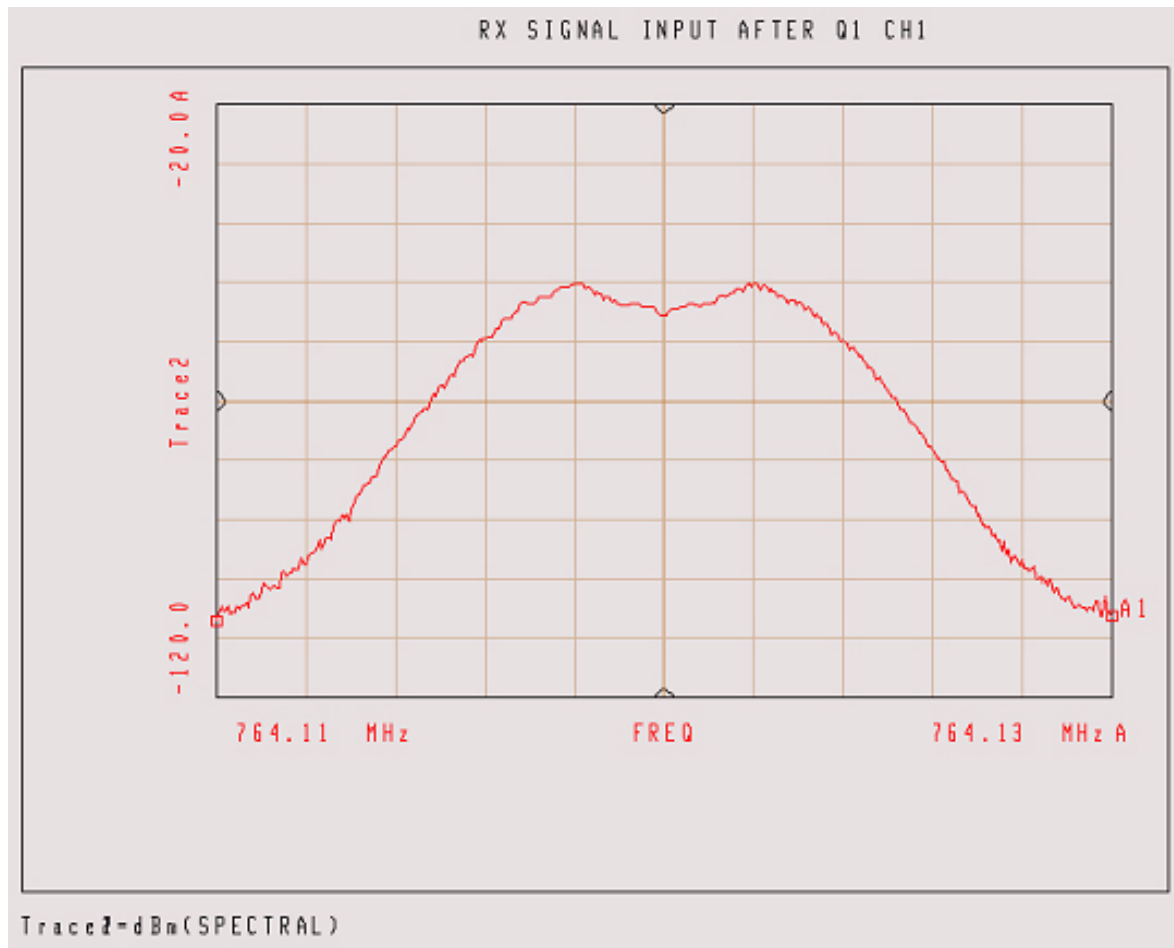

Probe point: FL2, pin 1.

Typical RX signal with 1 kHz modulation. Display shows modulation components of carrier.

7.4.29 PP25 Preselector 2 Output

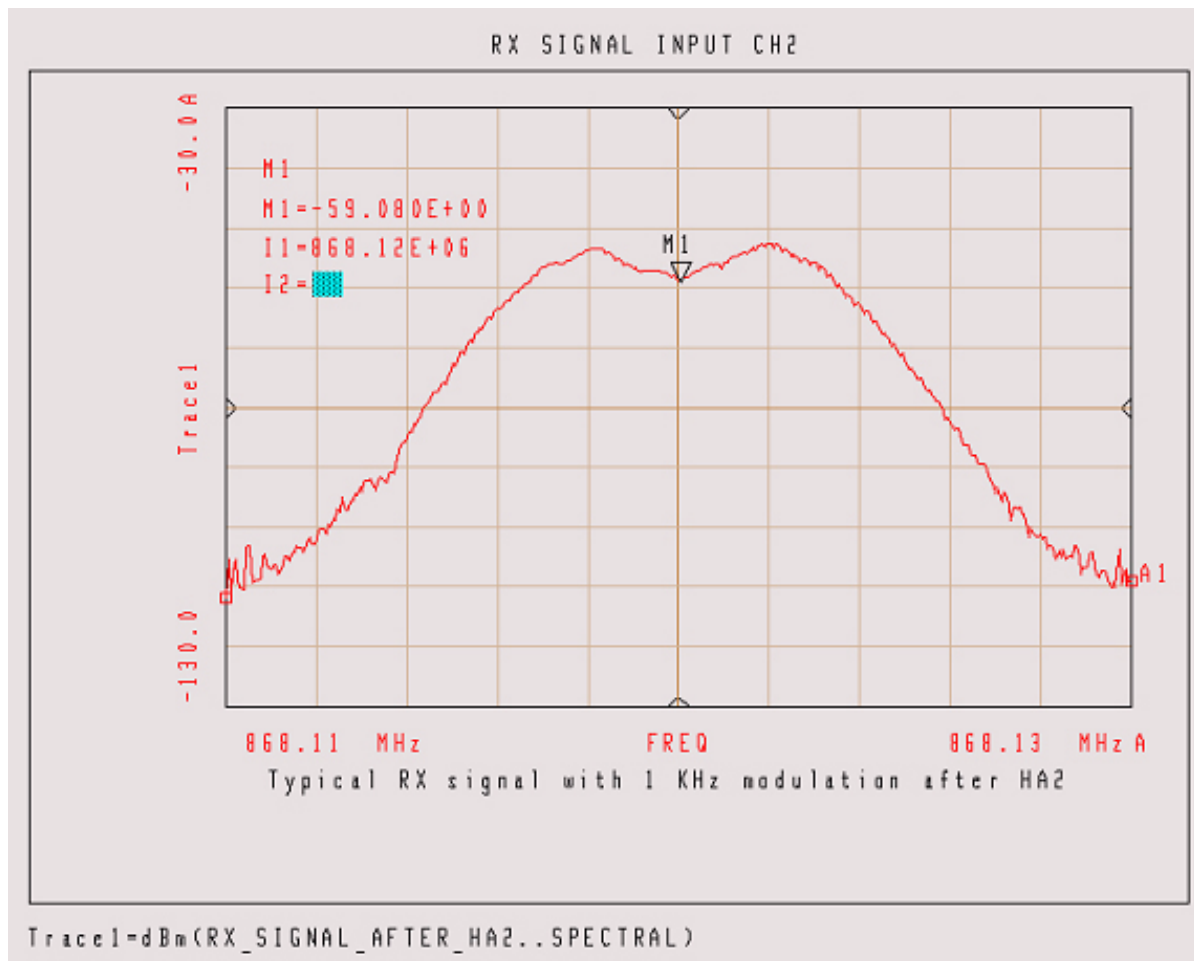

Probe point: FL2, pin 2.

Typical RX signal with 1 kHz modulation. Display shows modulation components of carrier.

7.4.30 PP26 Mixer Out (IF)

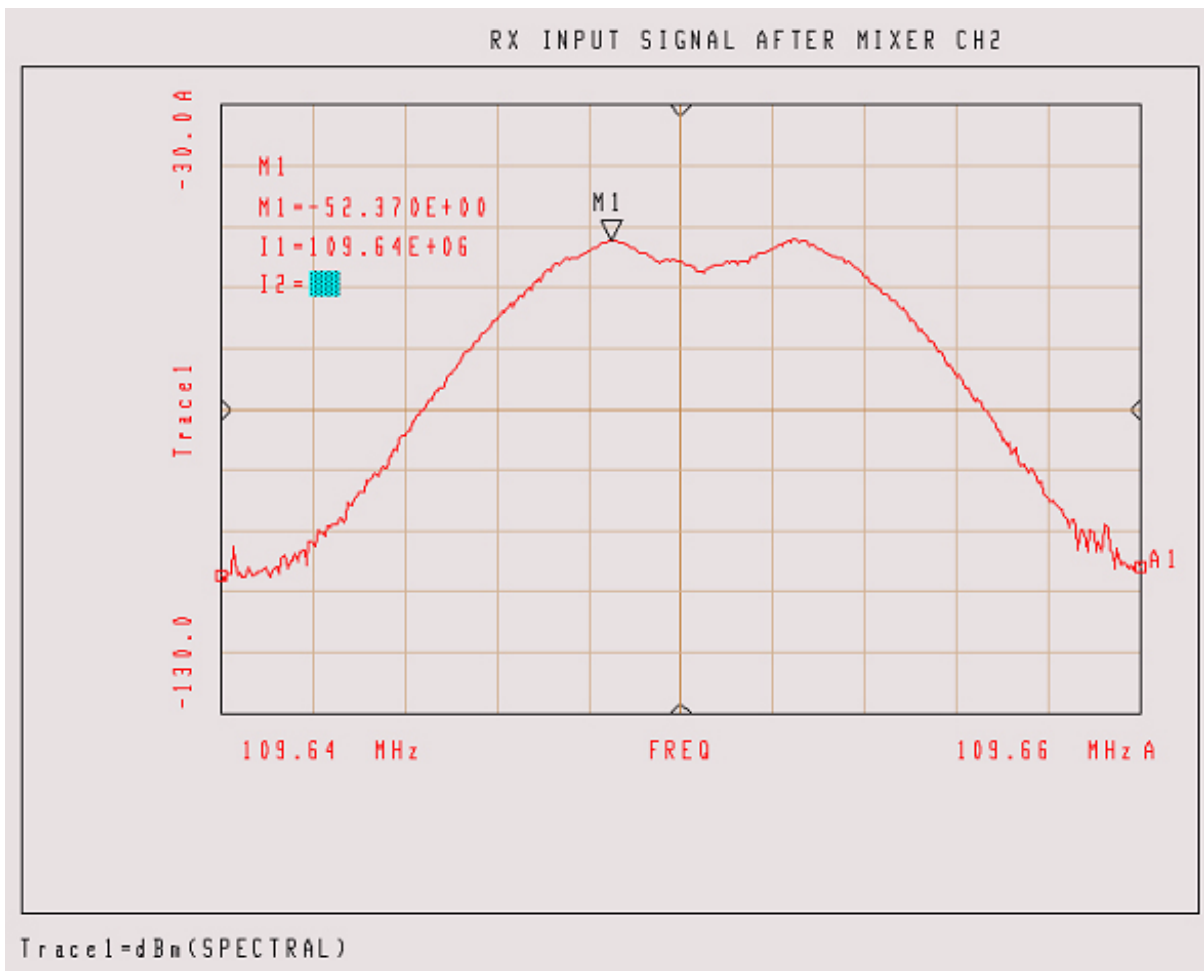

Probe point: U1, pin ?.

Typical RX signal with 1 kHz modulation. Display shows modulation components of carrier.

7.4.31 PP27 Crystal Filter Out

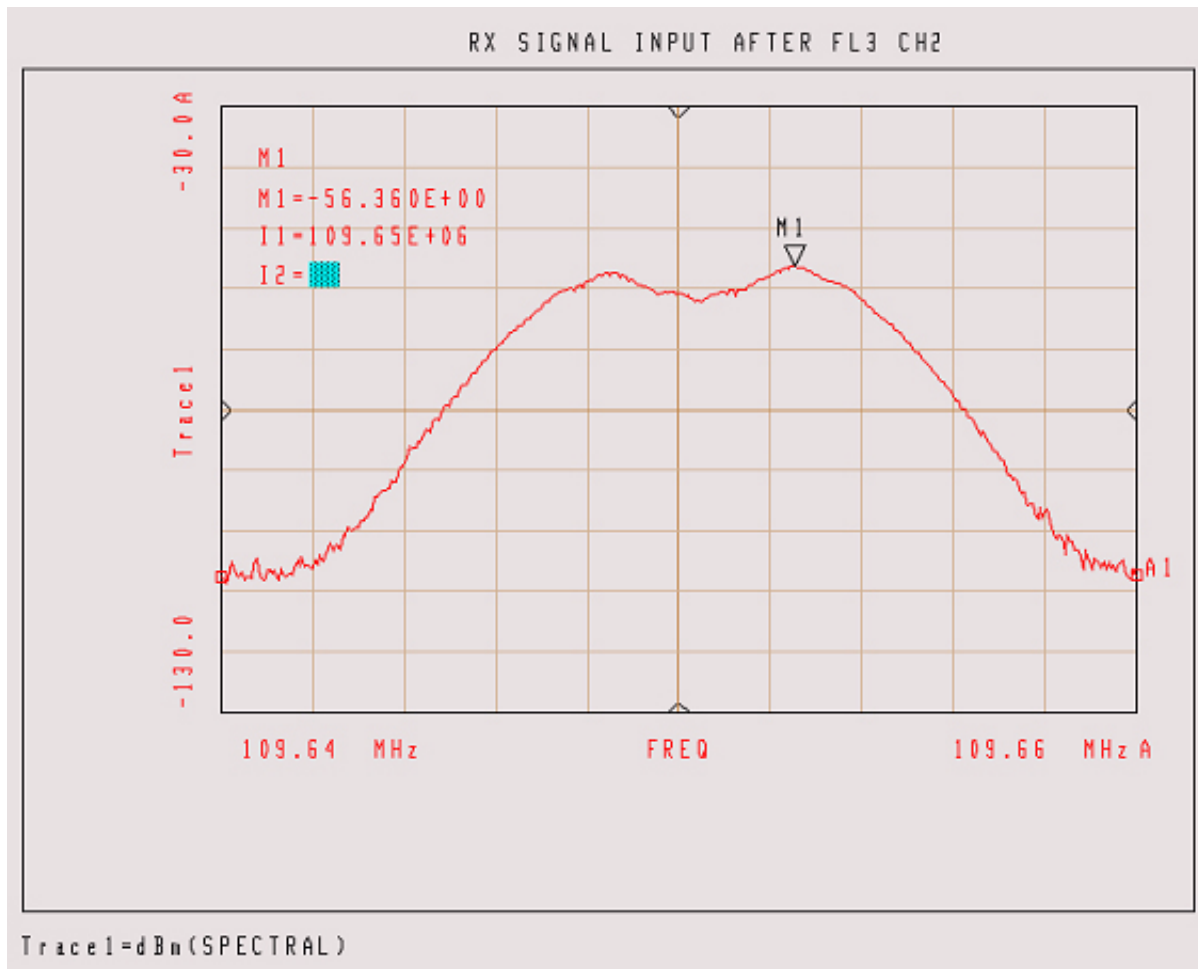

Probe point: FL3, pin ?.

7.4.32 PP28 Abacus Analog 3V

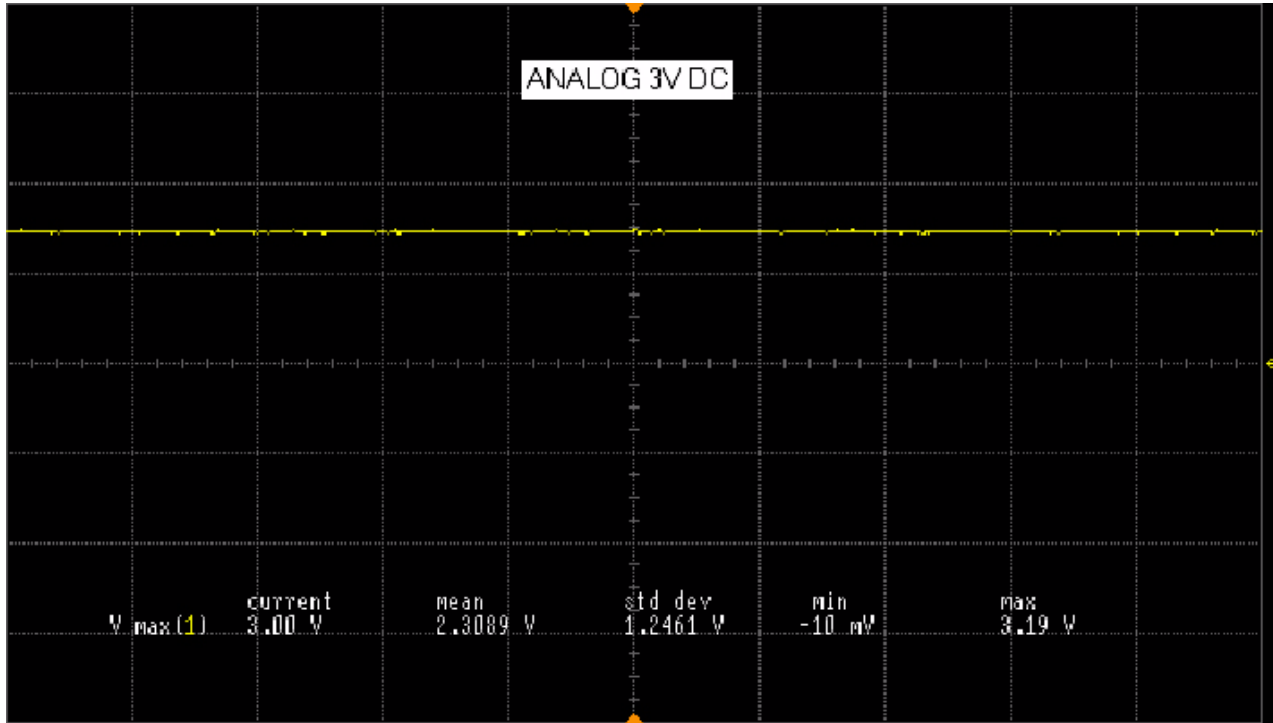

Probe point: U501, pin 5.

7.4.33 PP29 2nd LO Control Voltage

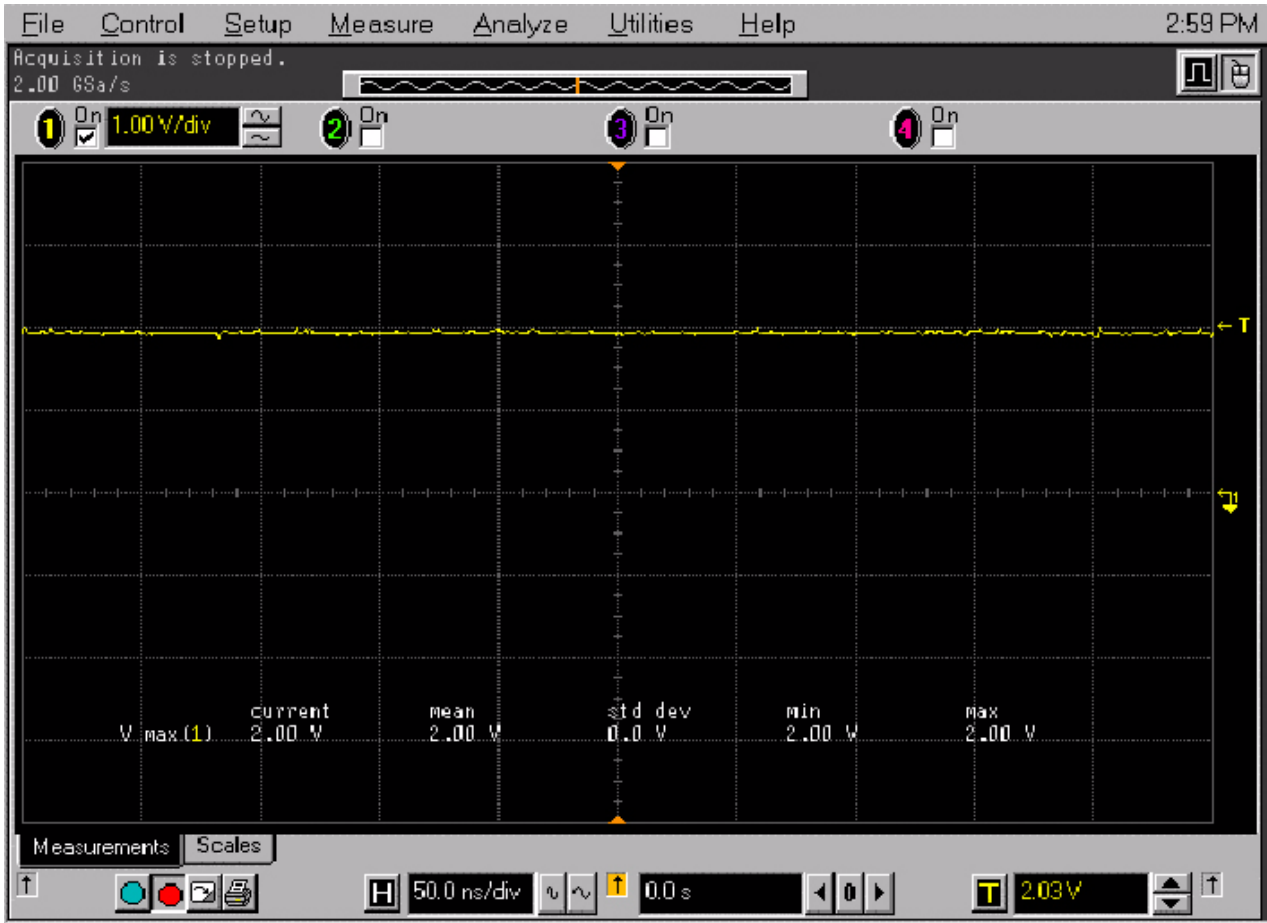

Probe point: U401, pin 38 (located under shield).

7.4.34 PP30 2nd LO VCO Buffer Output

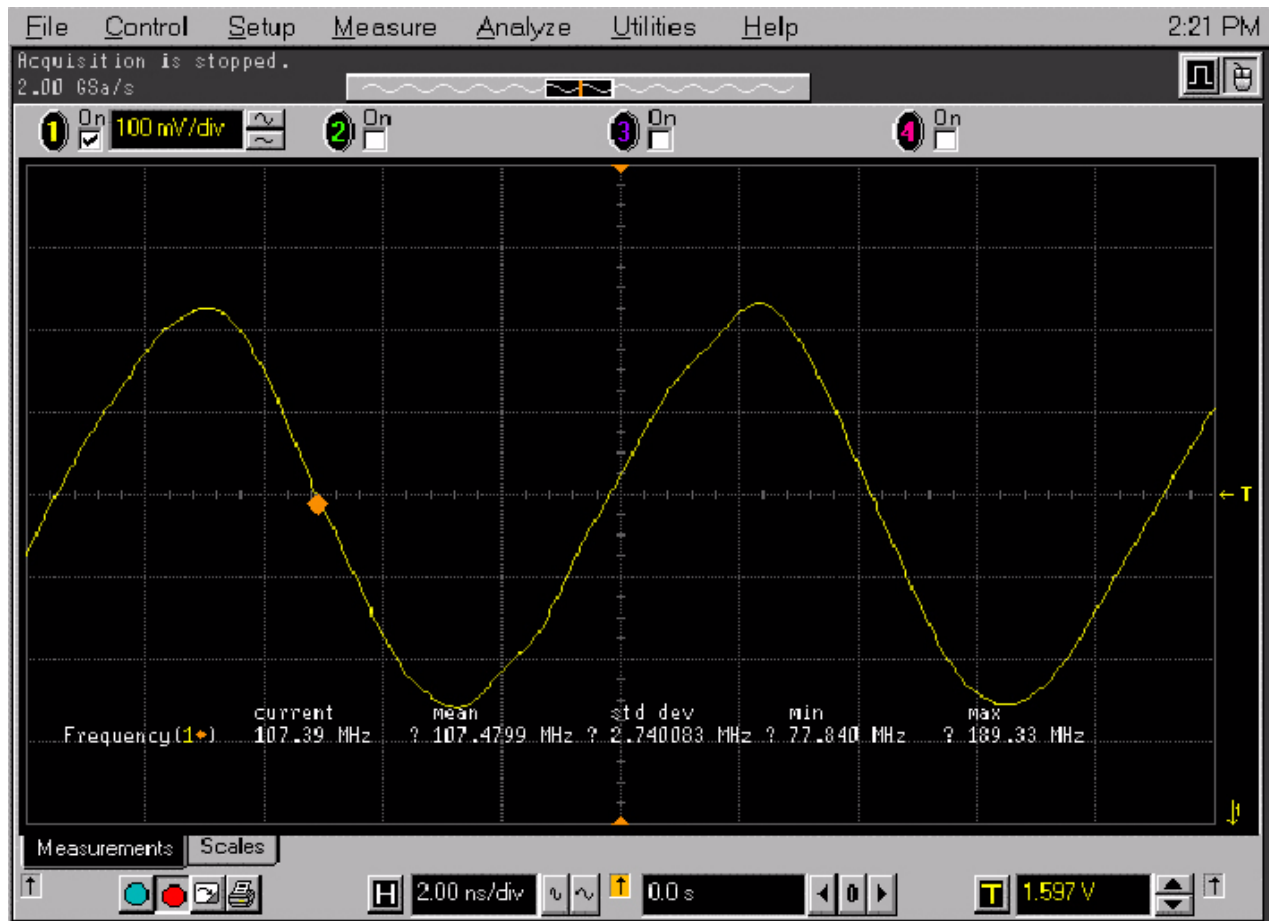

Probe point: Shield C407.

7.4.35 PP31 Analog 5V DC

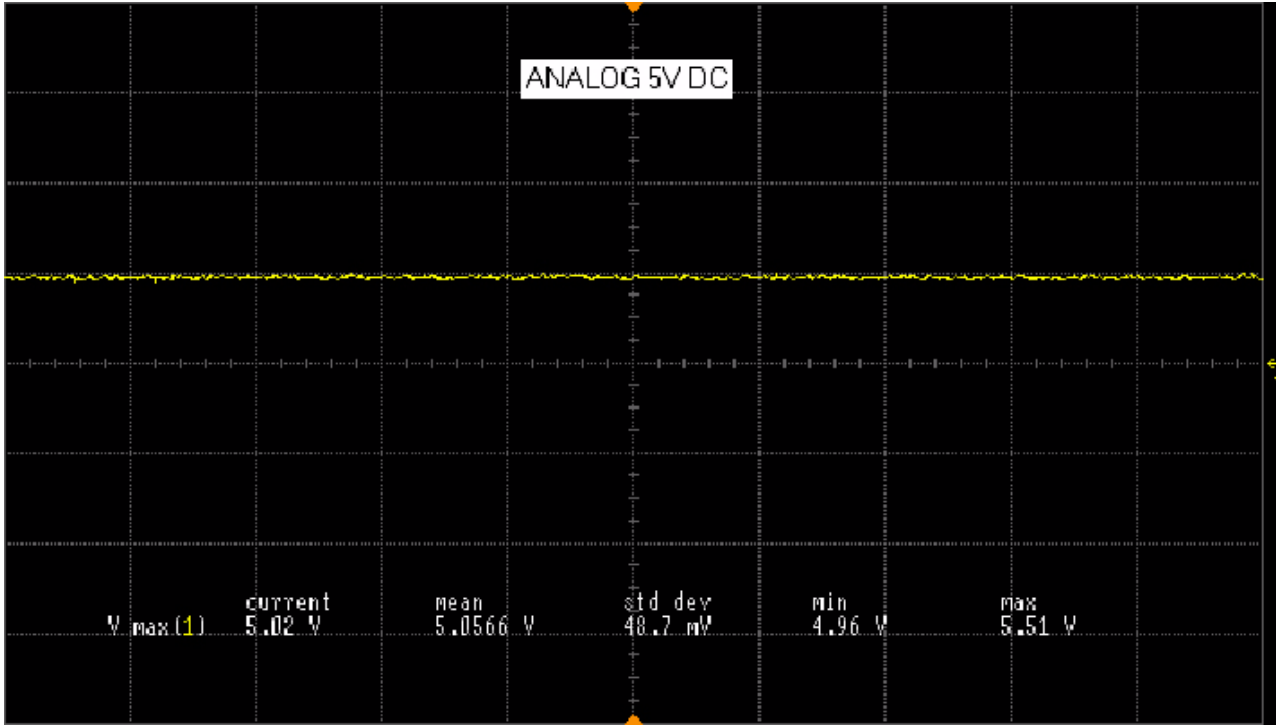

Probe point: U500, pin 5.

7.4.36 PP32 Abacus Digital 3V

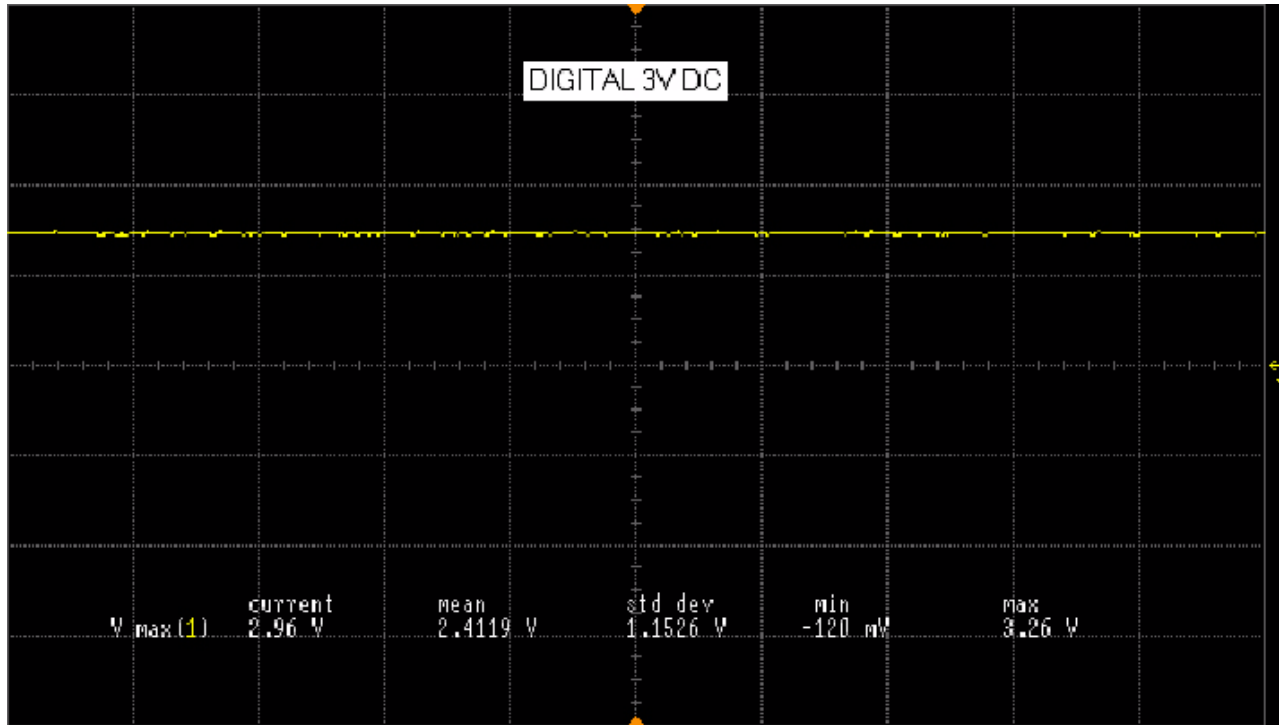

Probe point: U502, pin 5.

7.4.37 TX Audio 1 kHz Tone

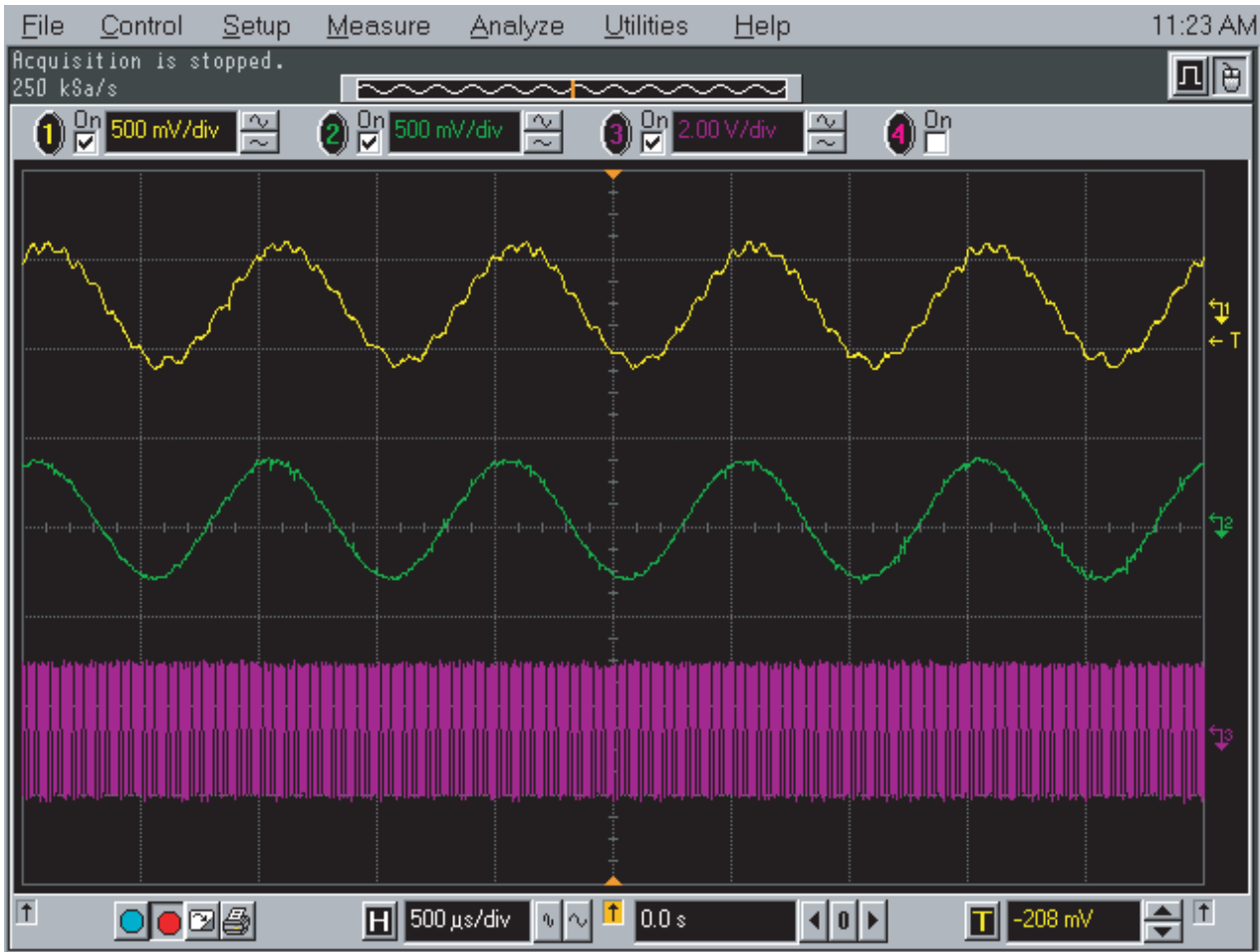

Trace 1: TP203 Mod In (640 mVp-p 1 kHz tone 1.5 Vdc)

Trace 2: U202, pin 1 (620 mVp-p 1 kHz tone)

Trace 3: FL200, pin 8 (1.2 MHz square wave 0 to 3 V)

Note: Transmit audio 1 kHz tone, which provides 3 kHz deviation.

7.4.38 16.8 MHz Buffer Input and Output

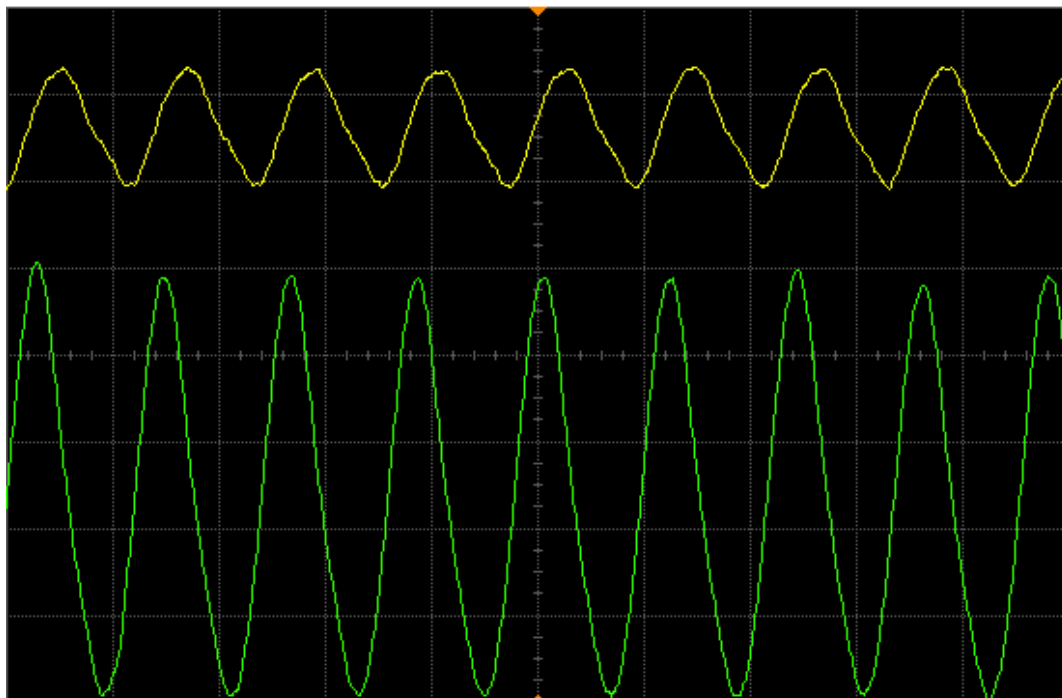

Acquisition	Sampling mode real time Configuration 4GSa/s Memory depth automatic Memory depth 1004pts Sampling rate automatic Sampling rate 2.00 GSa/s Averaging off 9-bit BW Filter off Interpolation on
Channel 1	Scale 200 mV/div Offset 644 mV Coupling DC Impedance 1M Ohm Attenuation 10.00 : 1 Atten units ratio Skew 0.0 s Ext adapter None Ext coupler None Ext gain 1.00E+00 Ext offset 0.0E+00
Channel 2	Scale 200 mV/div Offset 913 mV Coupling DC Impedance 1M Ohm Attenuation 10.00 : 1 Atten units ratio Skew 0.0 s Ext adapter None Ext coupler None Ext gain 1.00E+00 Ext offset 0.0E+00
Time base	Scale 50.0 ns/div Position 0.0 s Reference center
Trigger	Mode edge Sweep auto Hysteresis normal Holdoff time 60 ns Coupling DC Source channel 1 Trigger level 1.168 V Slope rising

Trace 1: Buffer input at R729.

Trace 2: Buffer output at C726.

Note: There should be no voltage gain between the Buffer's input and output. The 16.8MHz clock should be an approximately 1V peak-to-peak sine wave.

7.4.39 32.768 kHz Clock Outputs

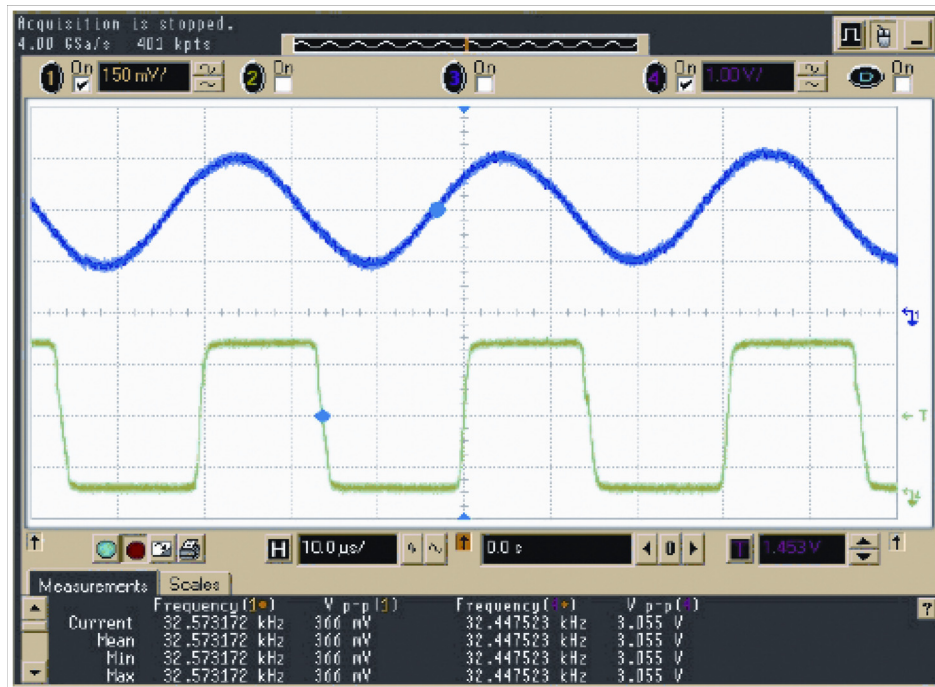

Trace 1: Output at C743.

Trace 2: Output at U712, pin 4.

7.4.40 SPI B Data

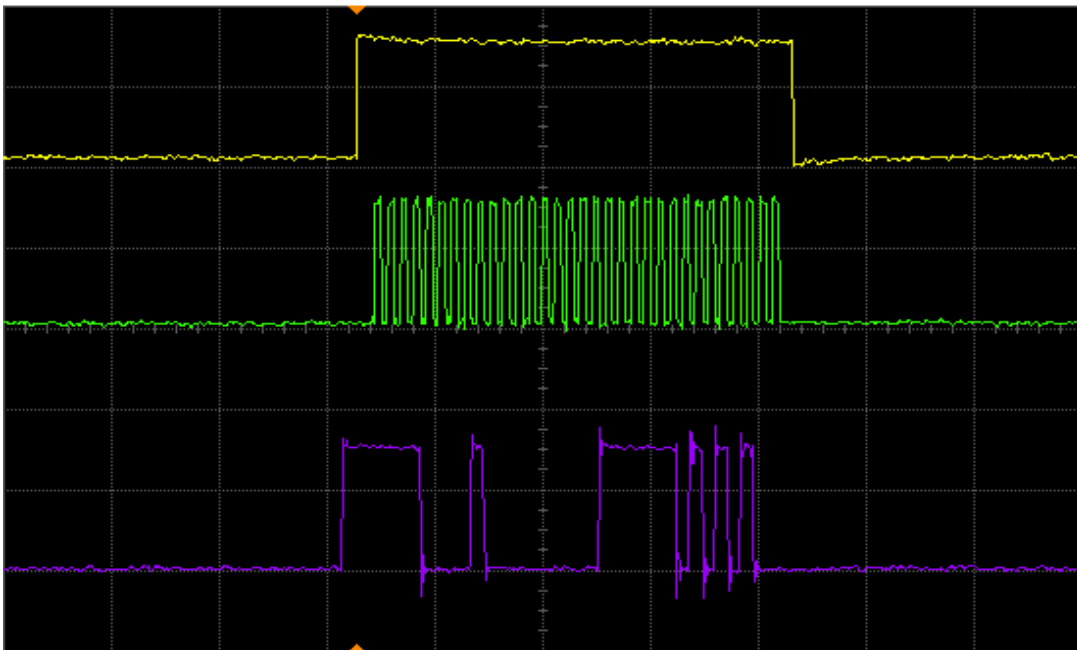

Acquisition	Sampling mode real time Configuration 4GSa/s Memory depth automatic Memory depth 1004pts Sampling rate automatic Sampling rate 50.0 MSa/s Averaging off 9-bit B'W Filter off Interpolation on
Channel 1	Scale 1.99 V/div Offset -4.21 V Coupling DC Impedance 1M Ohm Attenuation 10.00 : 1 Atten units ratio Skew 0.0 s Ext adapter None Ext coupler None Ext gain 1.00E+00 Ext offset 0.0E+00
Channel 2	Scale 2.00 V/div Offset -260 mV Coupling DC Impedance 1M Ohm Attenuation 10.00 : 1 Atten units ratio Skew 0.0 s Ext adapter None Ext coupler None Ext gain 1.00E+00 Ext offset 0.0E+00
Channel 3	Scale 2.00 V/div Offset 5.76 V Coupling DC Impedance 1M Ohm Attenuation 10.00 : 1 Atten units ratio Skew 0.0 s Ext adapter None Ext coupler None Ext gain 1.00E+00 Ext offset 0.0E+00
Time base	Scale 2.00 μ s/div Position 3.454546 μ s Reference center
Trigger	Mode edge Sweep auto Hysteresis normal Holdoff time 60 ns Coupling DC Source channel 1 Trigger level 810 mV Slope rising

Trace 1: MAKO chip enable, R767 (not active high)

Trace 2: SPI data clock, C619

Trace 3: SPI data to MAKO, C617.

7.4.41 RX Serial Audio Port (SAP)

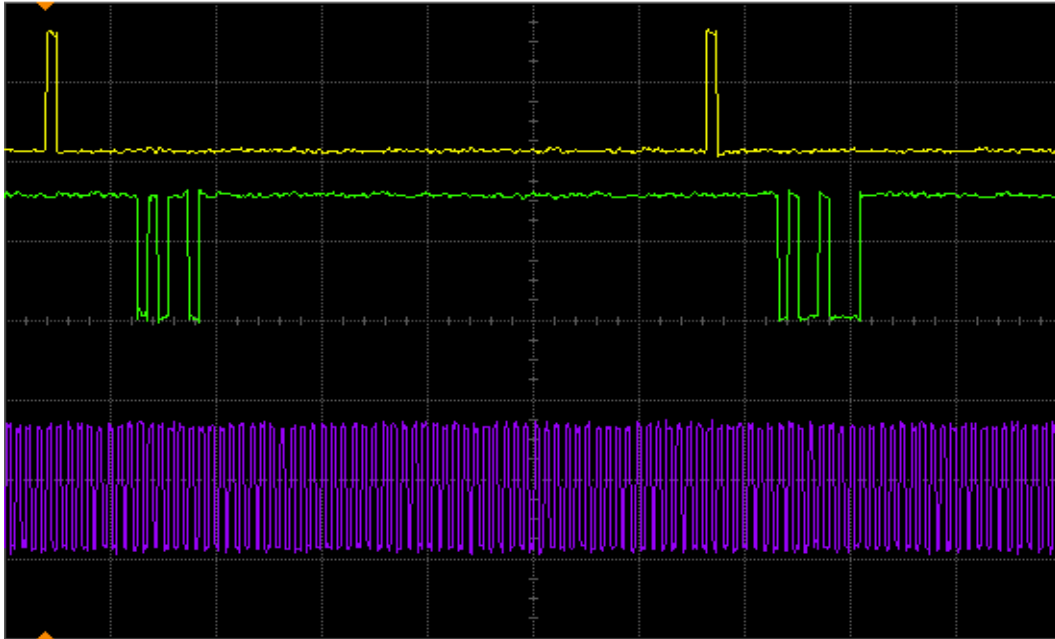

Acquisition	Sampling mode real time Configuration 4GSa/s Memory depth automatic Memory depth 1004pts Sampling rate automatic Sampling rate 5.00 MSa/s Averaging off 9-bit BW Filter off Interpolation on
Channel 1	Scale 1.99 V/div Offset -4.21 V Coupling DC Impedance 1M Ohm Attenuation 10.00 : 1 Atten units ratio Skew 0.0 s Ext adapter None Ext coupler None Ext gain 1.00E+00 Ext offset 0.0E+00
Channel 2	Scale 2.00 V/div Offset -210 mV Coupling DC Impedance 1M Ohm Attenuation 10.00 : 1 Atten units ratio Skew 0.0 s Ext adapter None Ext coupler None Ext gain 1.00E+00 Ext offset 0.0E+00
Channel 3	Scale 2.00 V/div Offset 5.55 V Coupling DC Impedance 1M Ohm Attenuation 10.00 : 1 Atten units ratio Skew 0.0 s Ext adapter None Ext coupler None Ext gain 1.00E+00 Ext offset 0.0E+00
Time base	Scale 20.0 μ s/div Position 92.181816 μ s Reference center
Trigger	Mode edge Sweep auto Hysteresis normal Holdoff time 60 ns Coupling DC Source channel 1 Trigger level 810 mV Slope rising

Note: TX is identical, except the data is probed at test point "TX".

Trace 1: 8 kHz frame sync (each word is 13 bits after falling edge of FSYNC)

Trace 2: SAP data at R626 (audio data from MAKO CODEC to Patriot DSP)

Note: Transmit is identical, except data acquired at R625

Trace 3: 512kHz bit clock at R616. (Codec_DCLK).

7.4.42 PP33 SPI Data

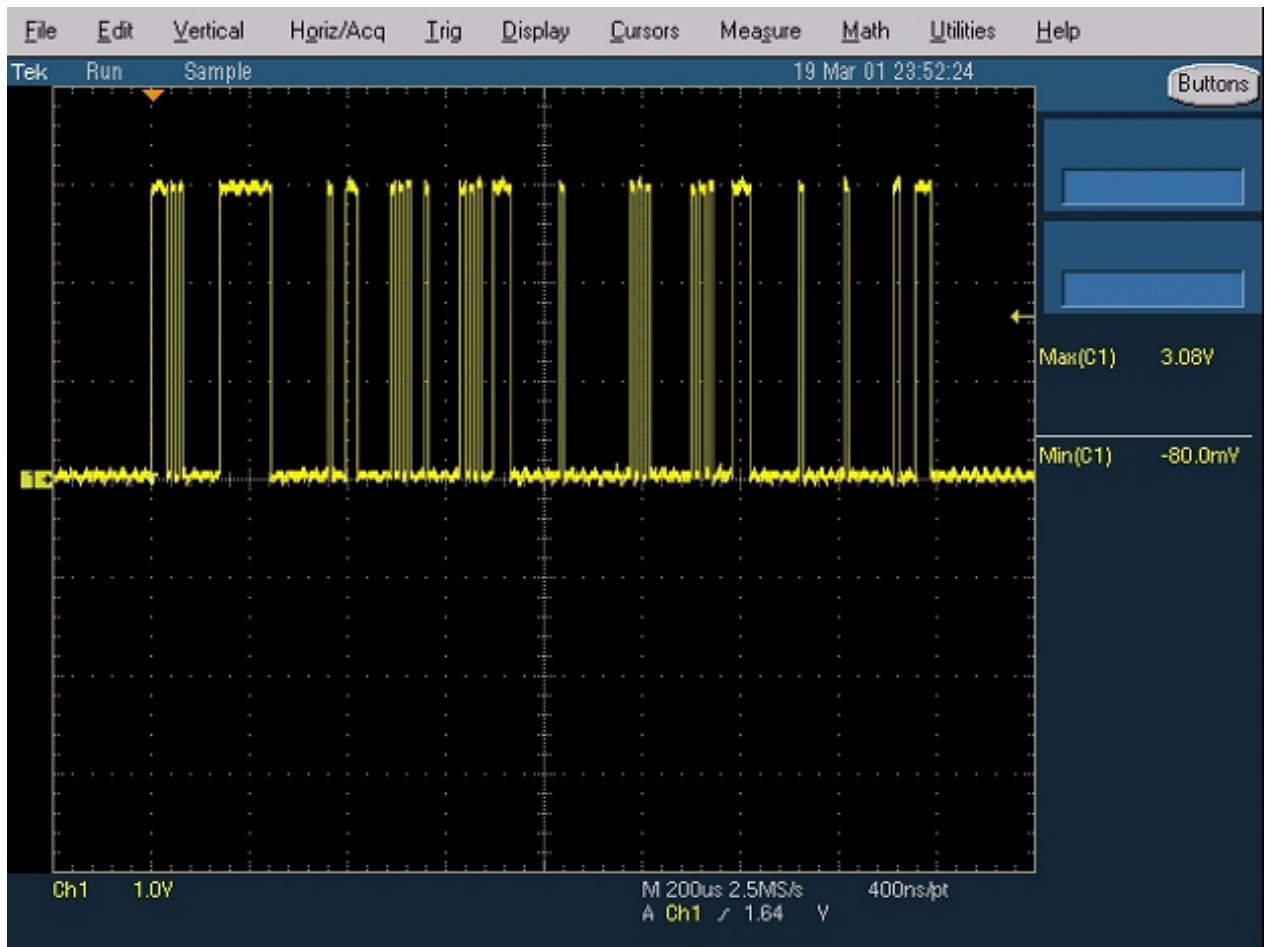

Probe Point: R802.

7.4.43 PP34 SPI CLK

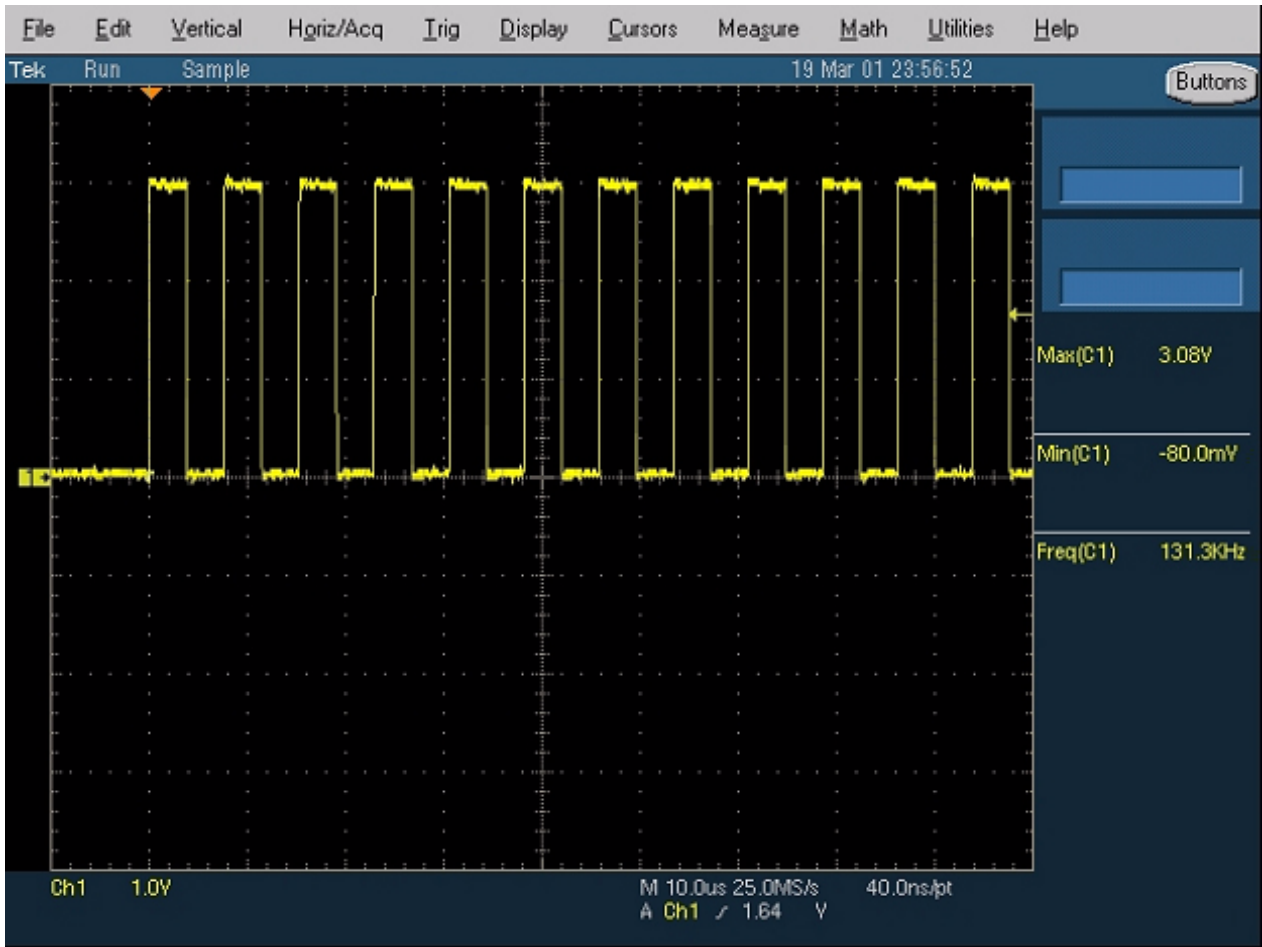

Probe Point: R803.

7.4.44 PP35 Universal Chip Select

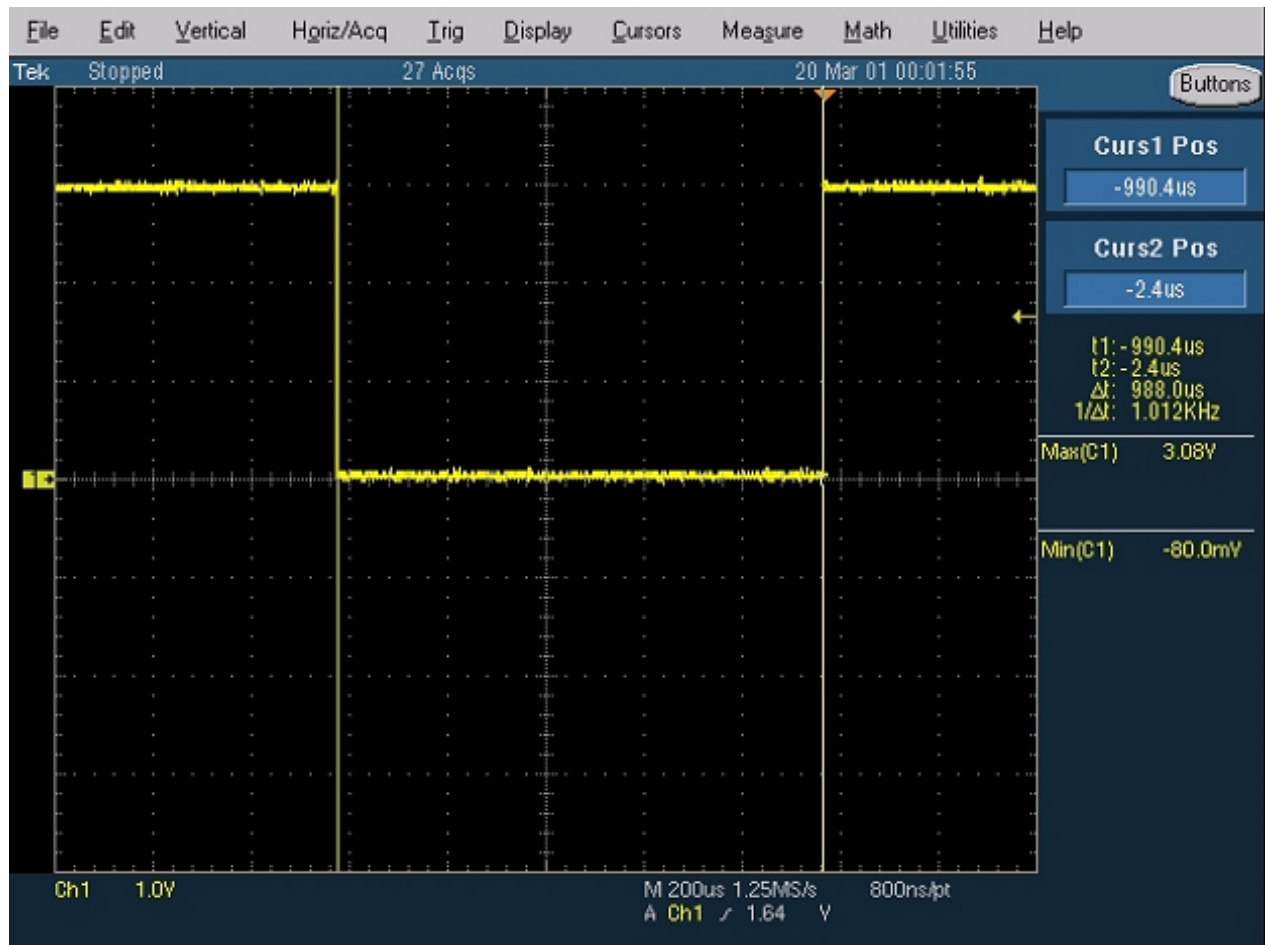

Probe Point: U102, pin 29 (located under shield).

7.4.45 PP36 Abacus Chip Select

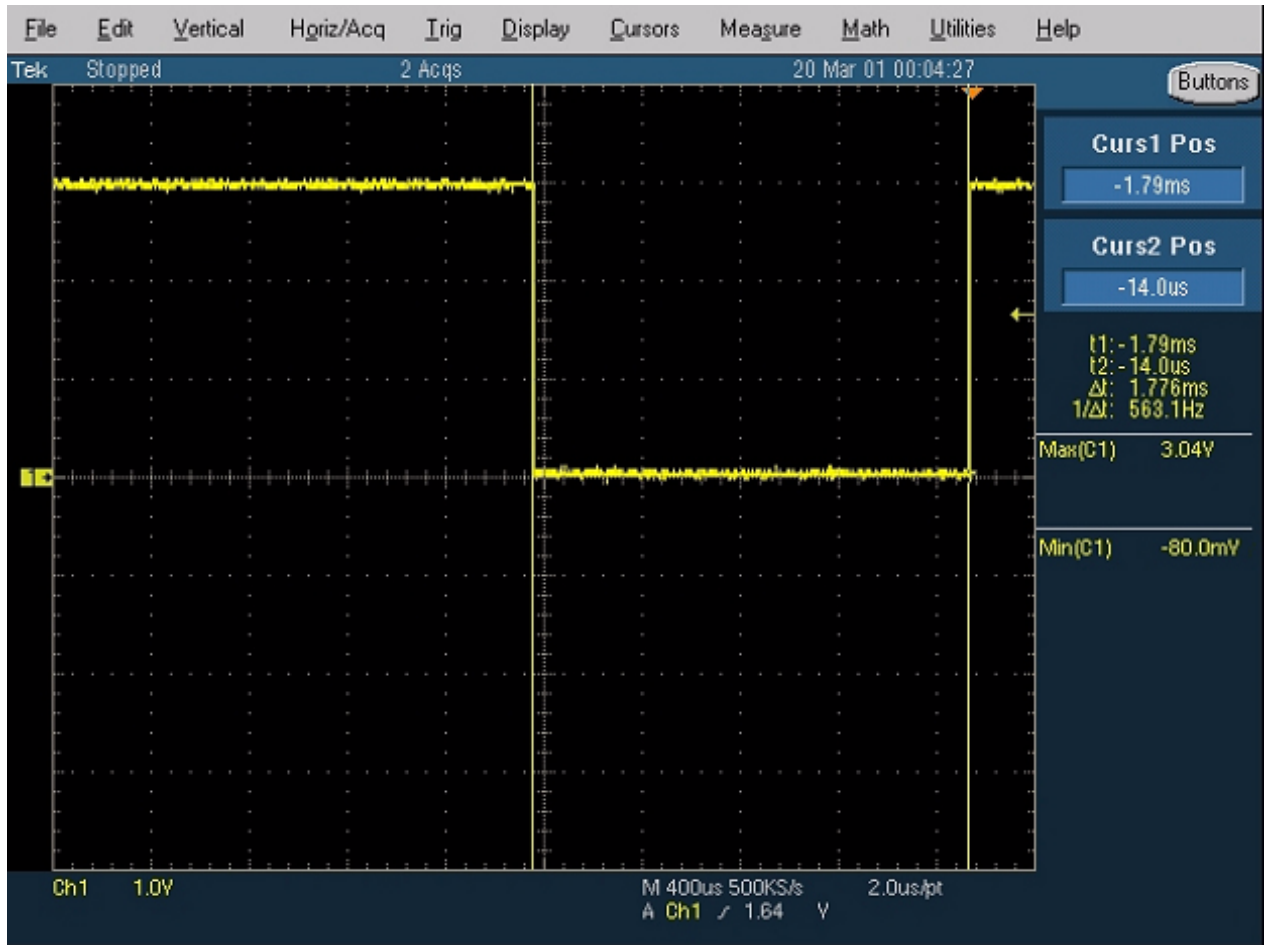

Probe Point: U401, pin 25 (located under shield).

7.4.46 TP37 RX SSI Data

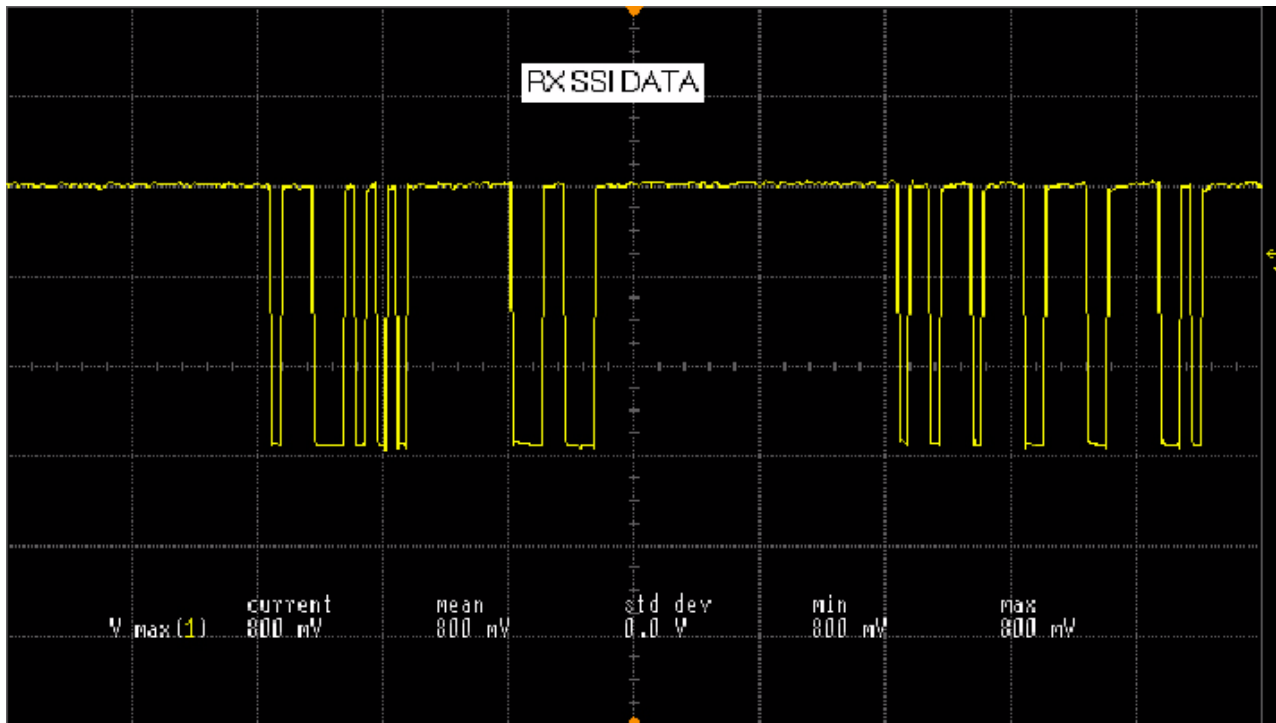

Test Point: TP403.

7.4.47 TP38 RX SSI Clock

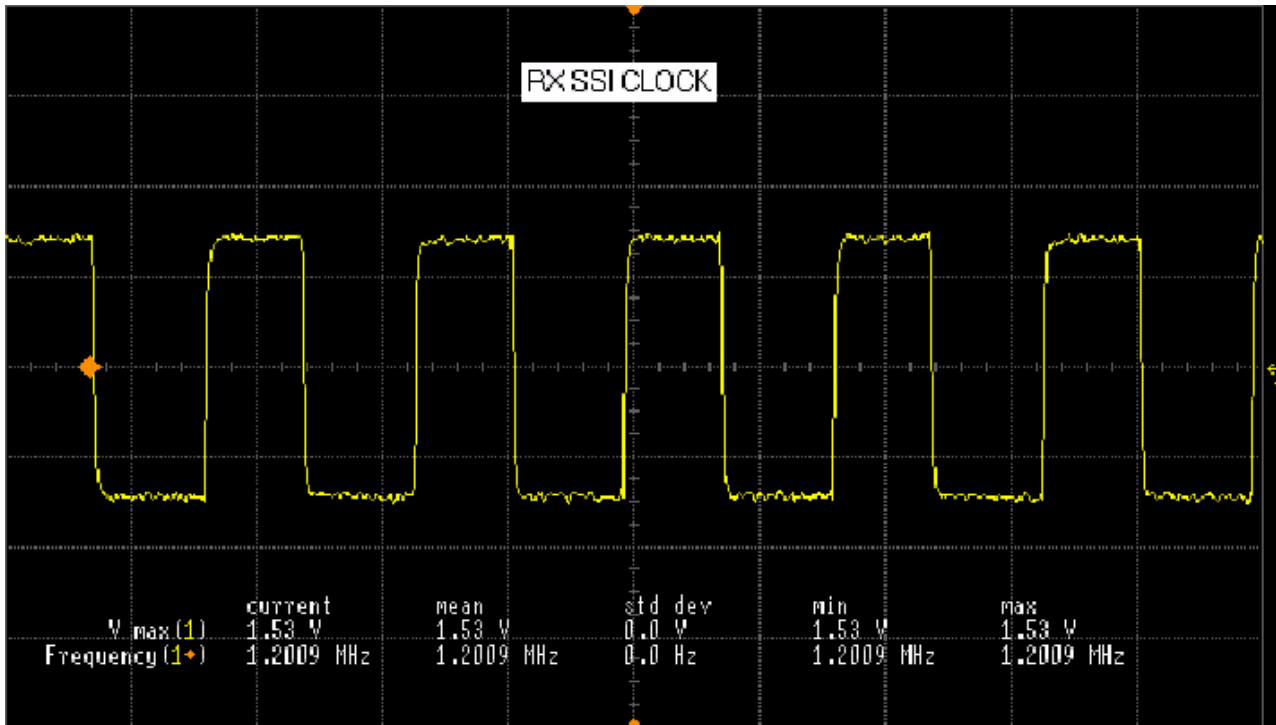

Test Point: TP404.

7.4.48 TP39 RX SSI Frame Sync

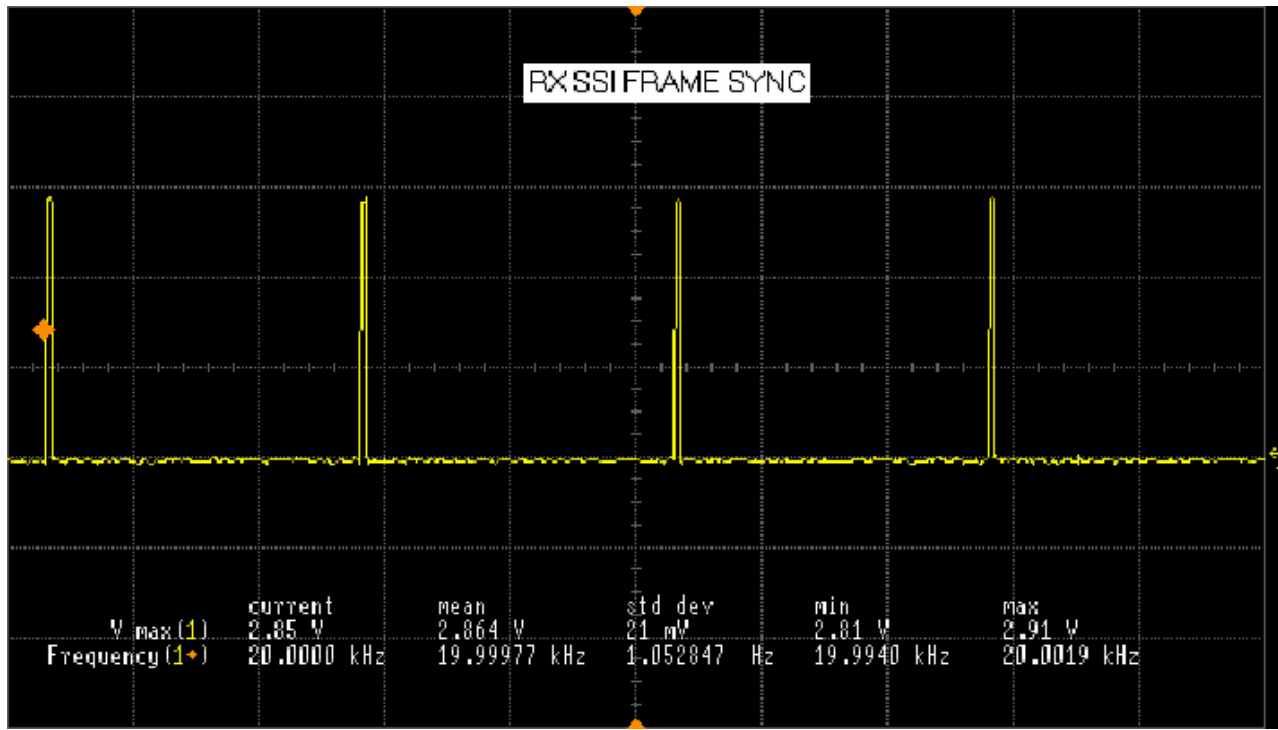

Test Point: TP402.

7.4.49 TP40 RX SSI Sync B

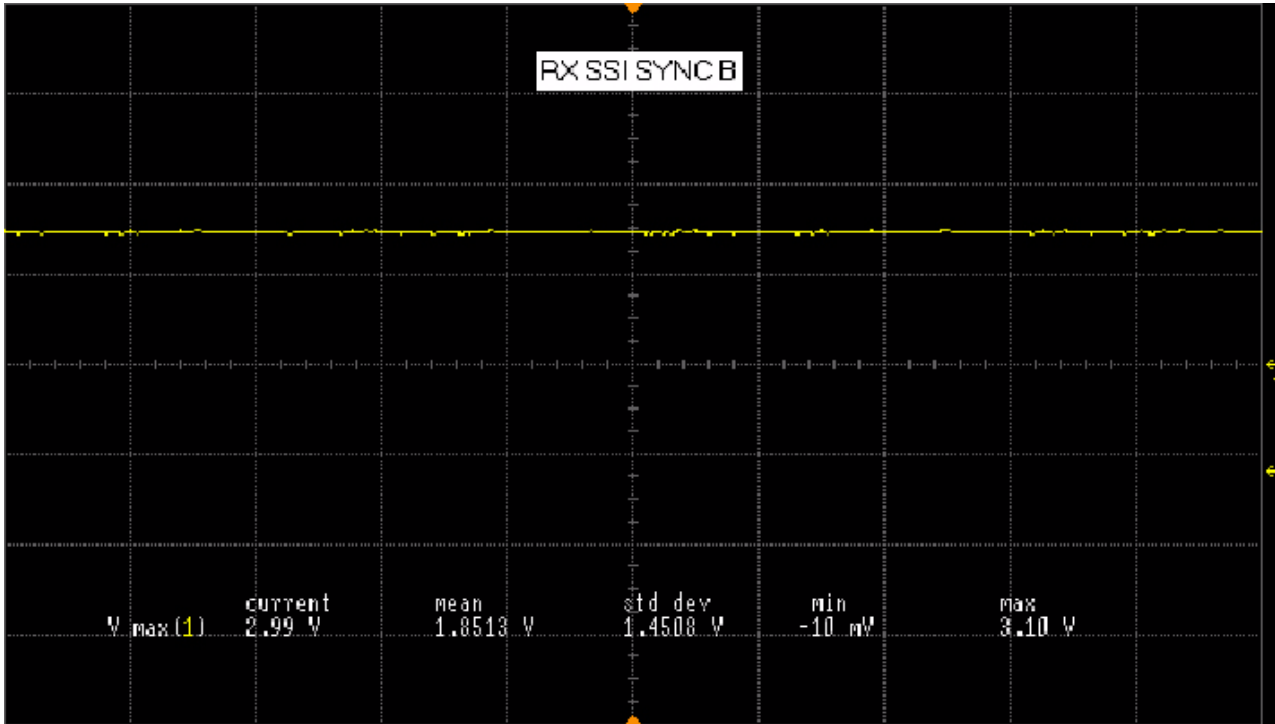

Test Point: TP401.

Chapter 7.5 Troubleshooting Waveforms

7.5.1 Introduction

This chapter contains images of waveforms that might be useful in verifying operation of certain parts of the circuitry. These waveforms are for reference only; the actual data depicted will vary depending upon operating conditions. This manual is to be used in conjunction with the ASTRO XTS 2500 Digital Portable Radios Basic Service Manual (Motorola part number 68P81094C09), which uses the pass/fail service approach to radio problems.

7.5.2 List of Waveforms

[Table 7.5-1](#) lists each waveform and the page on which the waveform can be found.

Table 7.5-1. List of Waveforms

Waveform	Page No.	Waveform	Page No.
Antenna Input	7.5-6	Low-Noise Amplifier Output	7.5-29
TX Signal at Harmonic Filter Input	7.5-7	Preselector 2 Output	7.5-30
Coupler RF Out	7.5-8	Mixer Out (IF)	7.5-31
TX Signal at PA	7.5-9	Crystal Filter Out	7.5-32
Coupler RF Feedback to PCIC	7.5-10	Abacus Analog 3V	7.5-33
PCIC Control Voltage	7.5-11	2nd LO Control Voltage	7.5-34
TX LO	7.5-12	2nd LO VCO Buffer Output	7.5-35
Higher Level Voltage Multiplier	7.5-13	Analog 5V	7.5-36
Superfilter Output	7.5-14	Abacus Digital 3V	7.5-37
TRB	7.5-15	TX Audio 1 kHz Tone	7.5-38
Prescaler Input to FracN Synthesizer	7.5-16	16.8 MHz Buffer Input and Output	7.5-39
Reference Crystal Output	7.5-17	32.768 kHz Clock Outputs	7.5-40
Mod In	7.5-18	SPI B Data	7.5-41
1st LO Control Voltage	7.5-19	RX Serial Audio Port (SAP)	7.5-42
VCO Output	7.5-20	SPI Data	7.5-43
VCO RX LO	7.5-21	SPI CLK	7.5-44
Frequency Out (16.8 MHz)	7.5-22	Universal Chip Select	7.5-45
RX RF Input at Antenna Switch	7.5-23	Abacus Chip Select	7.5-46
Antenna Switch Bias	7.5-24	RX SSI Data	7.5-47
Preselector Tuning Voltage	7.5-25	RX SSI Clock	7.5-48
RX RF Input after Antenna Switch	7.5-26	RX SSI Frame Sync	7.5-49
Analog 5V	7.5-27	RX SSI Sync B	7.5-50
Preselector 1 Output	7.5-28		

7.5.3 RF Test Points

The following RF block diagram and accompanying table (Table 7.5-2) shows the location of key probe points (PP) and test points (TP) for the XTS 2500 radio.

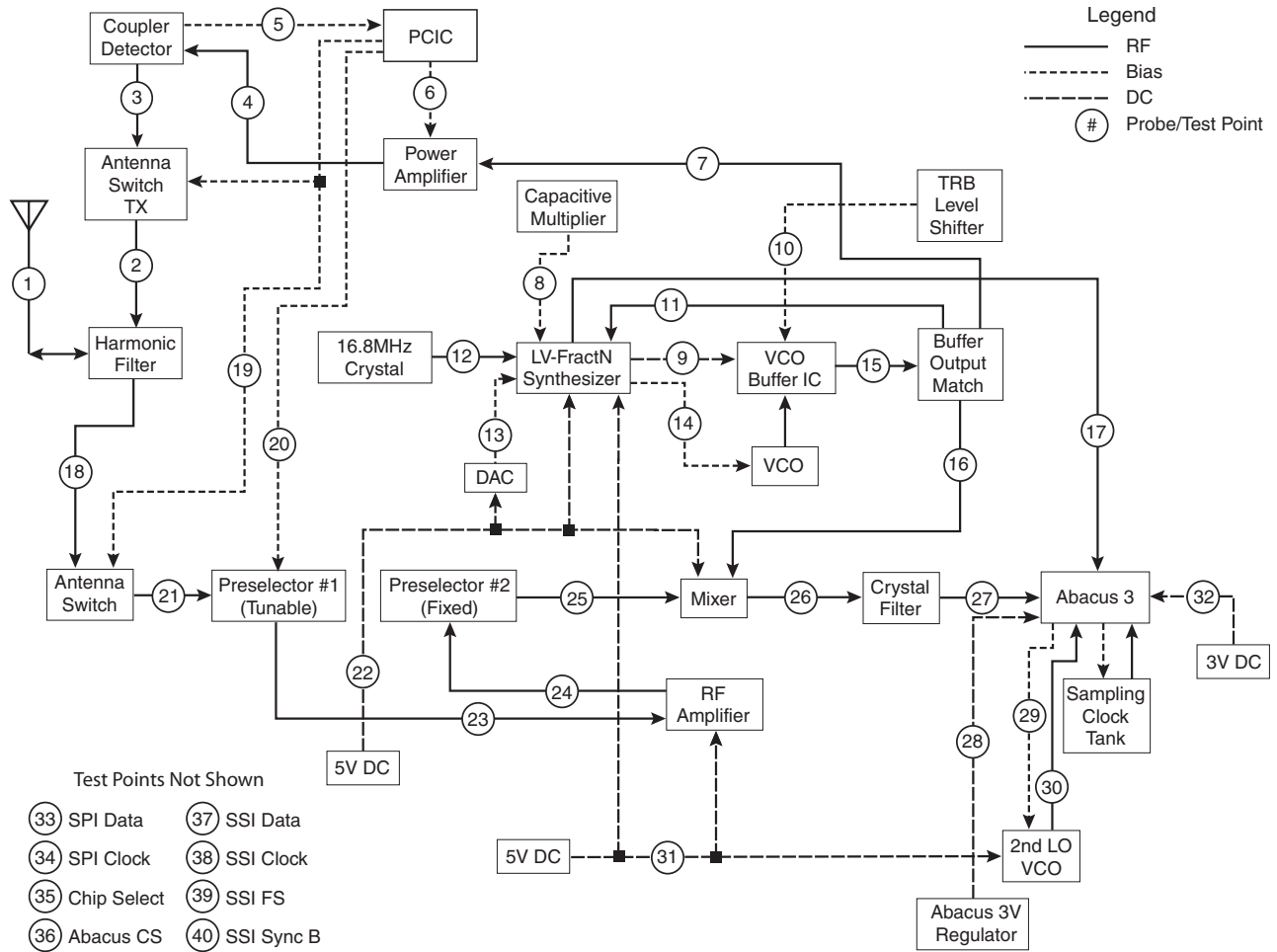

MAEPF-27353-O

Figure 7.5-1. RF Block Diagram Test Points

Table 7.5-2. RF Block Diagram Probe/Test Points

PP/TP	Name	Location	Under RF Shield?	Page
1	Antenna Input	J101, pin 5	No.	7.5-6
2	TX Signal at Harmonic Filter Input	C105	Yes.	7.5-7
3	Coupler RF Out	U103, pin 1	No.	7.5-8
4	TX Signal at PA	Q101, pin 2	No.	7.5-9
5	Coupler RF Feedback to PCIC	TP102	No.	7.5-10
6	PCIC Control Voltage	TP101	No.	7.5-11
7	TX LO	Tx_inj	No.	7.5-12
8	Higher Level Voltage Multiplier	C203	Yes.	7.5-13
9	Superfilter Output	C240	Yes.	7.5-14
10	TRB	R262	No.	7.5-15
11	Prescaler Input to FracN Synthesizer	C236	Yes.	7.5-16
12	Reference Crystal Output	R294, C289	No.	7.5-17
13	Mod In	TP203	No.	7.5-18
14	1st LO Control Voltage	TP202	No.	7.5-19
15	VCO Output	*	Yes.	7.5-20
16	VCO RX LO	C261	Yes.	7.5-21
17	Frequency Out (16.8 MHz)	C293	No.	7.5-22
18	RX RF Input at Antenna Switch	FL1, pin 1	No.	7.5-23
19	Antenna Switch Bias	U103, pin 1	No.	7.5-24
20	Preselector Tuning Voltage	FL1, pin 3; FL2, pin 3	No.	7.5-25
21	RX RF Input after Antenna Switch	FL1, pin 1	No.	7.5-26
22	Analog 5V	U500, pin 5	No.	7.5-27
23	Preselector 1 Output	FL1, pin 2	No.	7.5-28
24	Low-Noise Amplifier Output	FL2, pin 1	No.	7.5-29
25	Preselector 2 Output	FL2, pin 2	No.	7.5-30
26	Mixer Out (IF)	L10	No.	7.5-31
27	Crystal Filter Out	C413	No.	7.5-32
28	Abacus Analog 3V	U501, pin 5	No.	7.5-33
29	2nd LO Control Voltage	U401, pin 38	Yes.	7.5-34
30	2nd LO VCO Buffer Output	C407	No.	7.5-35
31	Analog 5V	U500, pin 5	No.	7.5-36
32	Abacus Digital 3V	U502, pin 5	No.	7.5-37
33	SPI Data	R802	No.	7.5-43
34	SPI CLK	R803	No.	7.5-44
35	Universal Chip Select	U102, pin 29	Yes.	7.5-45

Table 7.5-2. RF Block Diagram Probe/Test Points (Continued)

PP/TP	Name	Location	Under RF Shield?	Page
36	Abacus Chip Select	U401, pin 25	Yes.	7.5-46
37	RX SSI Data	TP403	No.	7.5-47
38	RX SSI Clock	TP404	No.	7.5-48
39	RX SSI Frame Sync	TP402	No.	7.5-49
40	Rx SSI Sync B	TP401	No.	7.5-50

PP = Probe Point
 TP = Test Point

* C261 for LO Output
 C266 for TX Output
 C236 for Preselector Output

Note: For test/probe points indicated with the SH prefix, use an HP 85024A High Frequency Probe to detect a signal. The probe should be placed in center of the hole located on the top of the shield. Make sure the probe does not touch the shield or any other components.

7.5.4 Main Circuit Board RF Shield Locations

Viewed from Side 1

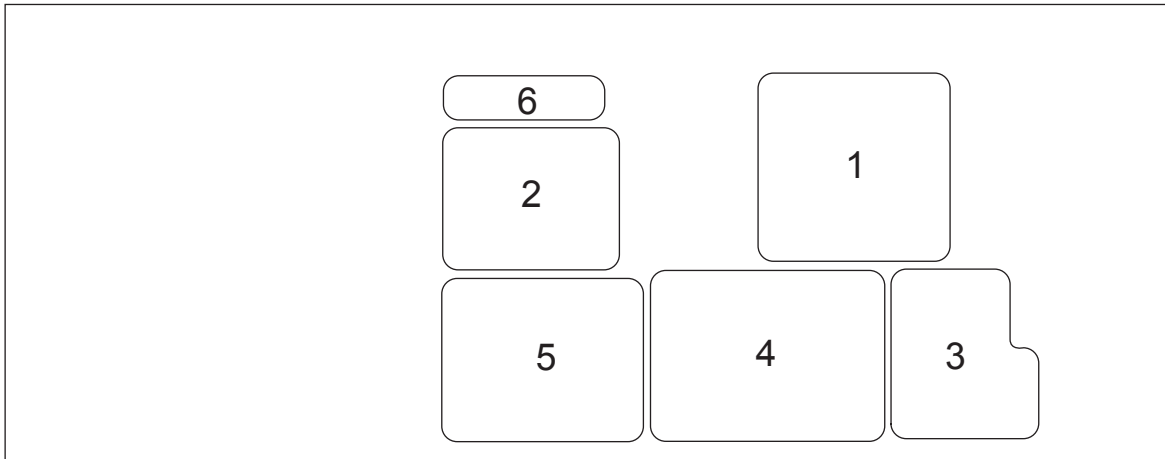

MAEPF-27489-O

Table 7.5-3. Main Circuit Board Side 1 RF Shields

Item Number	Reference Number	Motorola Part Number	Description
1	SH401	2616552H01	Shield, ABACUS
2	SH201	2616560H01	Shield, Synthesizer
3	SH103	2616558H01	Shield, Harmonic Top
4	SH104	2616555H01	Shield, PA
5	SH205	2616554H01	Shield, VCO Top
6	SH204	2616551H01	Shield, DAC

Viewed from Side 2

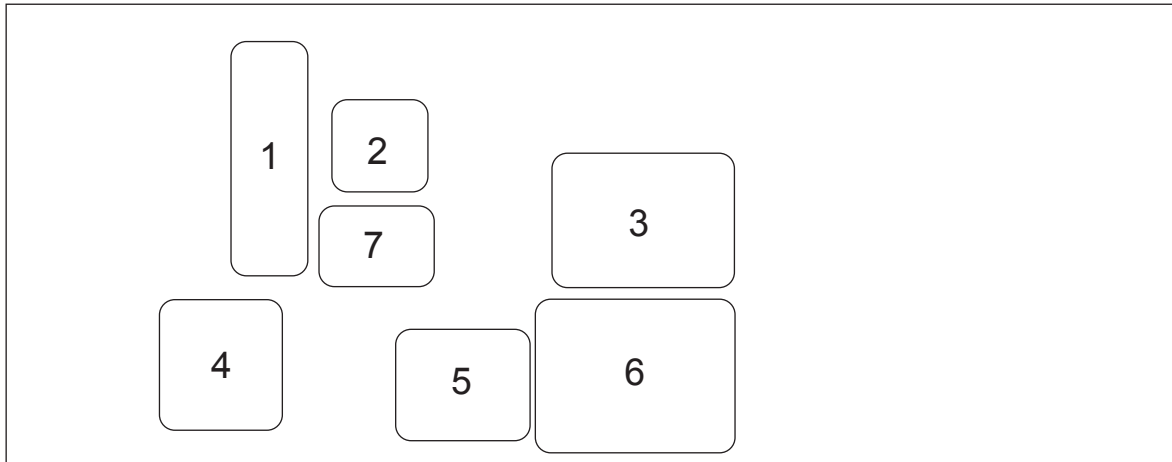

MAEPF-27488-O

Table 7.5-4. Main Circuit Board Side 2 RF Shields

Item Number	Reference Number	Motorola Part Number	Description
1	SH1	2616071H01	Shield, Mixer
2	SH402	2616518H01	Shield, 2nd LO
3	SH202	2616556H01	Shield, Frac-N
4	SH102	2616557H01	Shield, Harmonic Bottom
5	SH101	2616559H01	Shield, PCIC
6	SH203	2616553H01	Shield, VCO Bottom
7	SH2	2616550H01	Shield, Crystal IF

7.5.5 PP1 Antenna Input

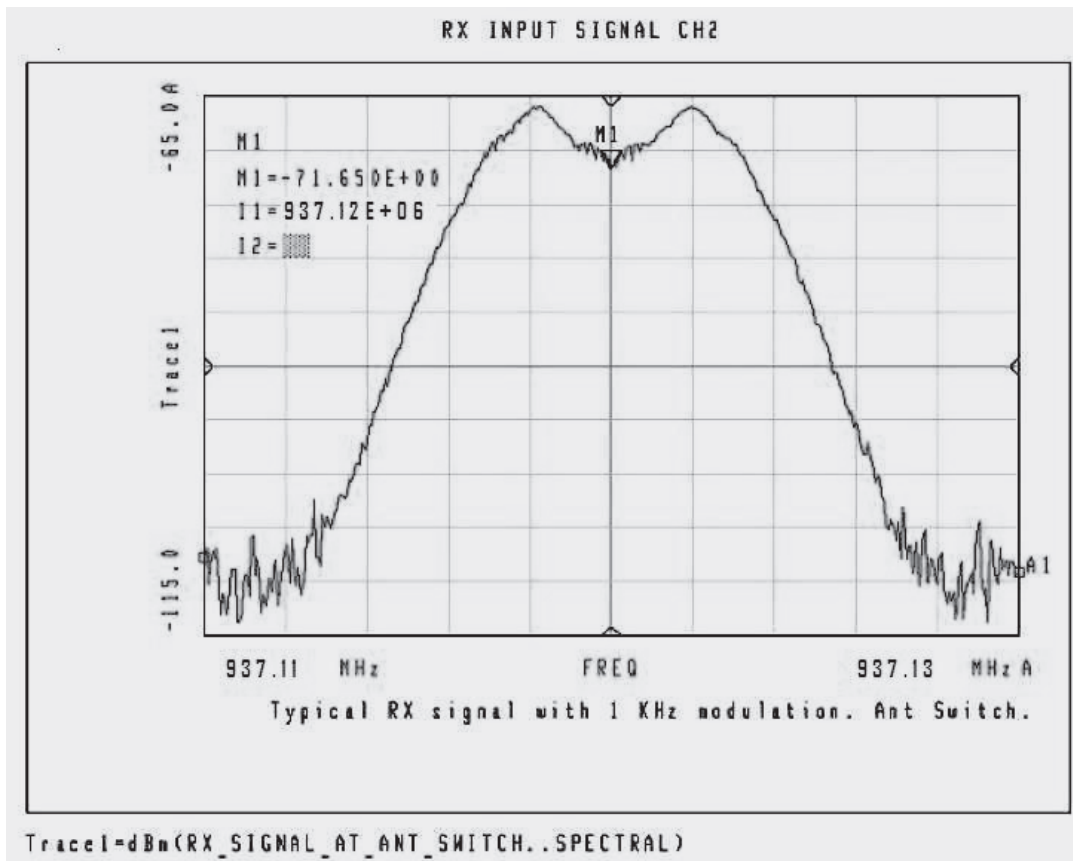

Probe point: J101, pin 5.

Typical RX signal with 1 kHz modulation. Display shows modulation components of carrier.

7.5.6 PP2 TX Signal at Harmonic Filter Input

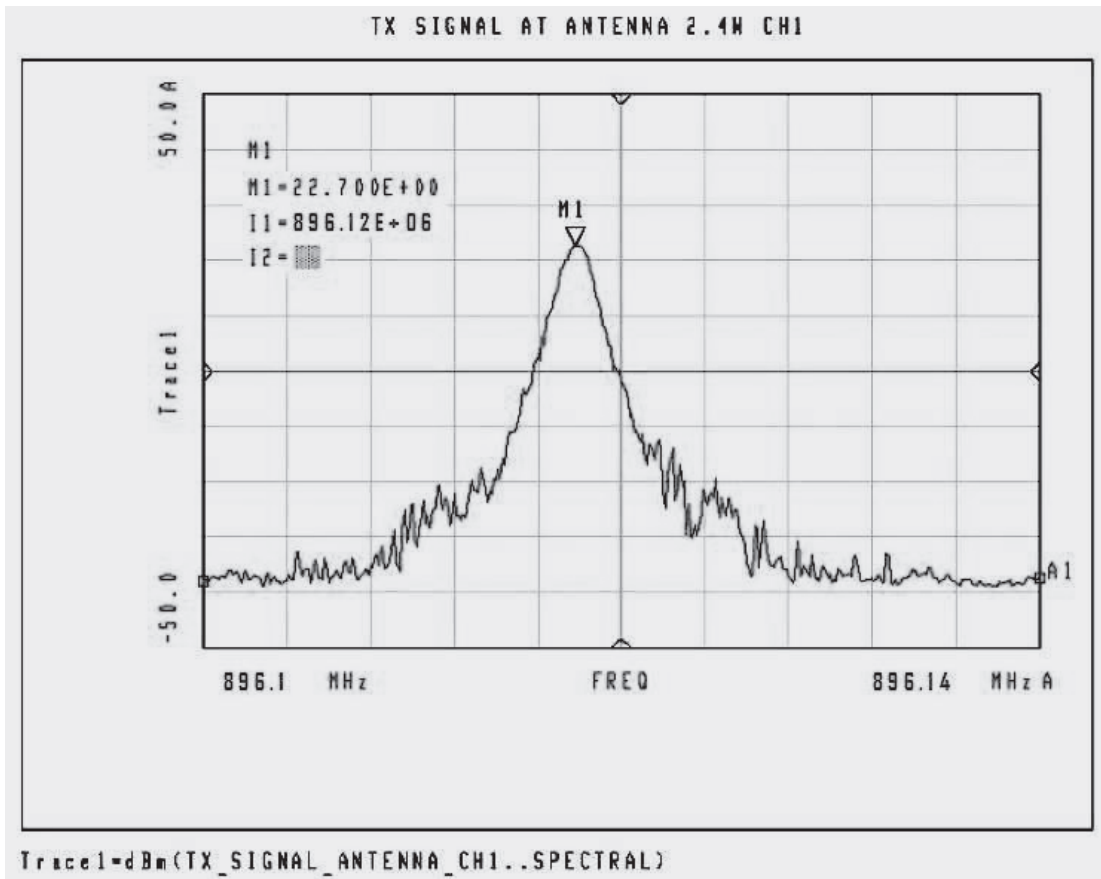

Probe point: C105 (located under shield).

7.5.7 PP3 Coupler RF Out

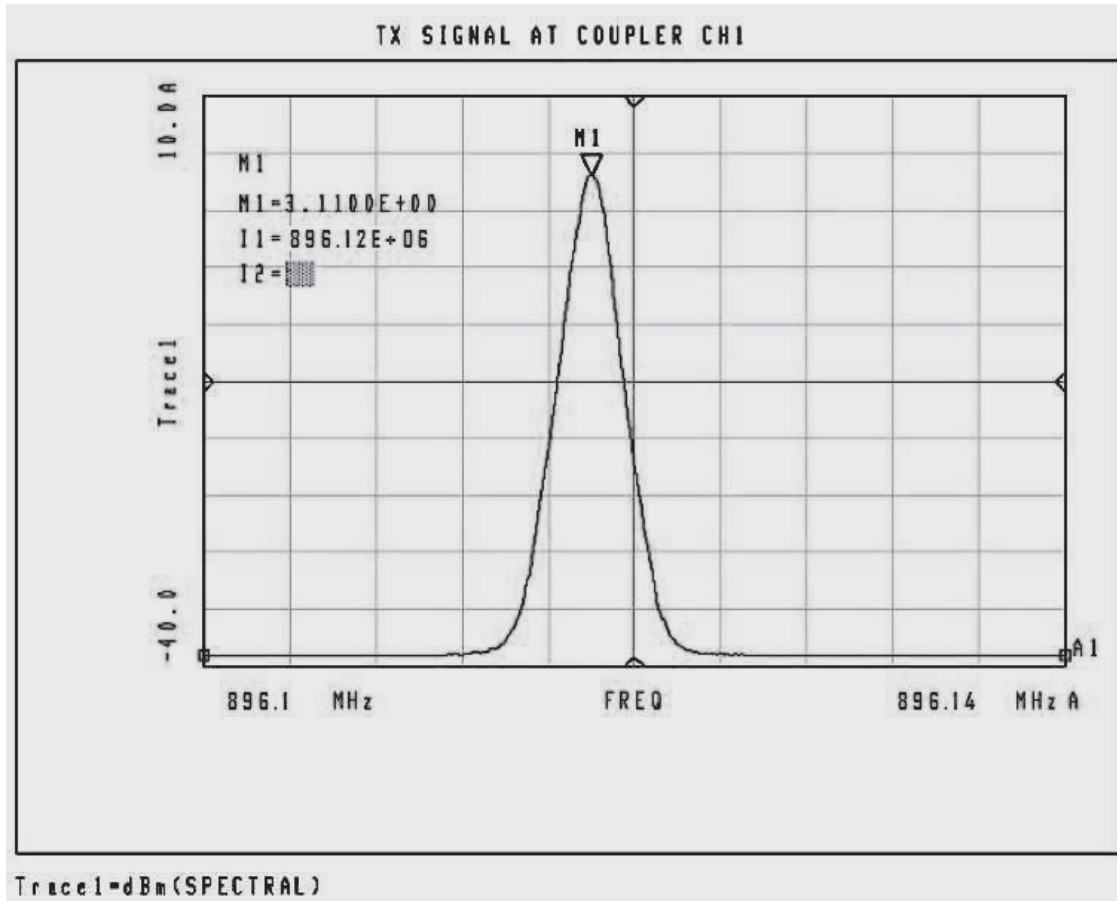

Probe point: U103, pin 1.

7.5.8 PP4 TX Signal at PA

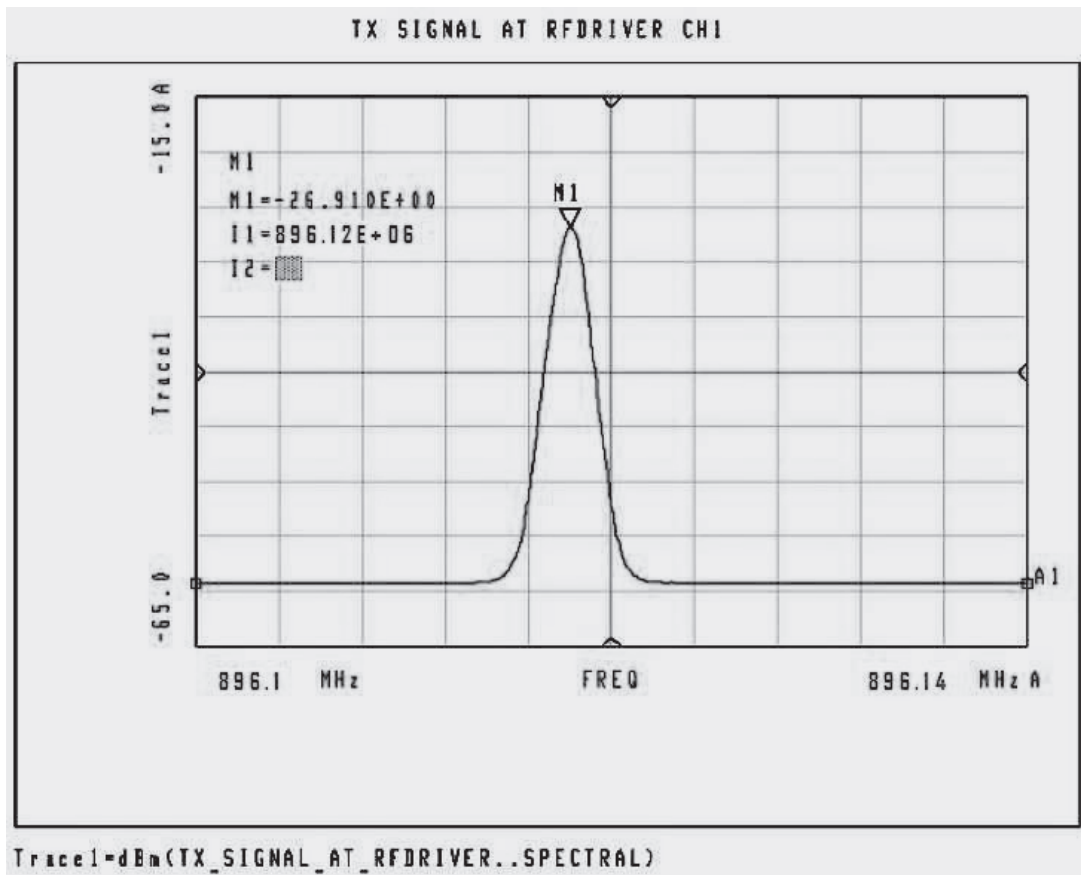

Probe point: Q101, pin 2.

7.5.9 TP5 Coupler RF Feedback to PCIC

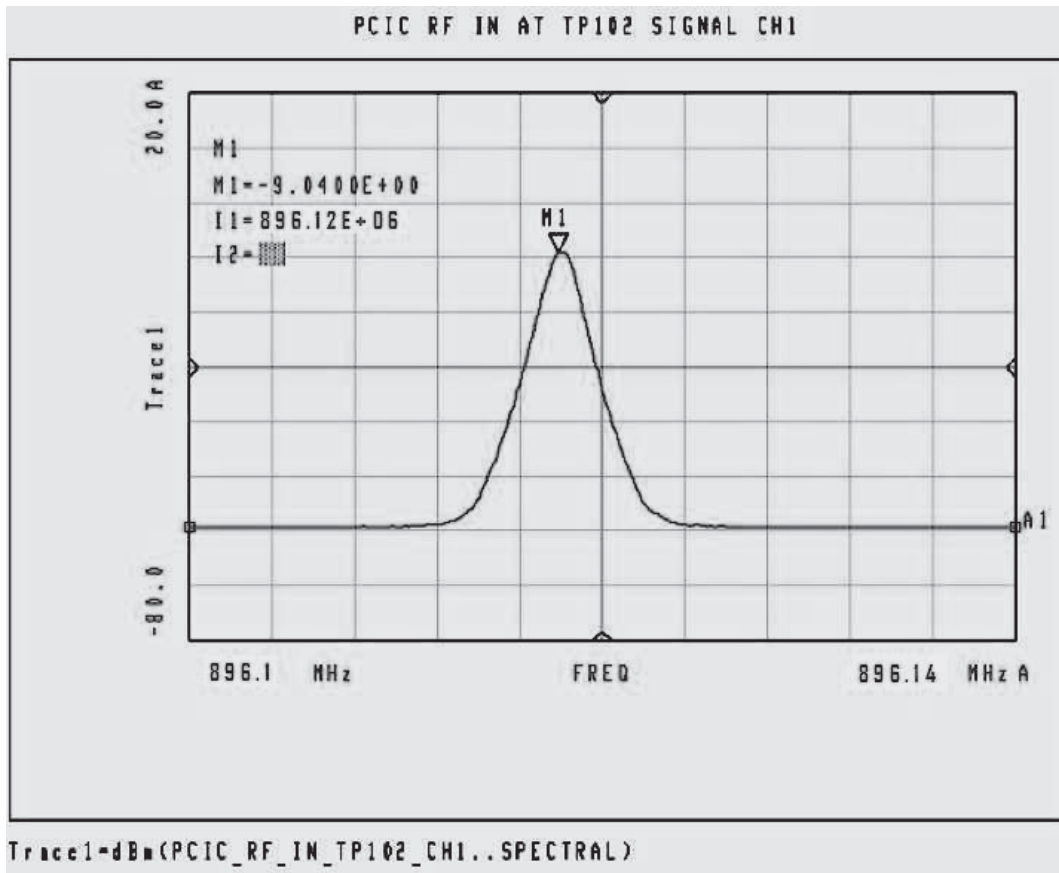

Test point: TP102.

7.5.10 TP6 PCIC Control Voltage

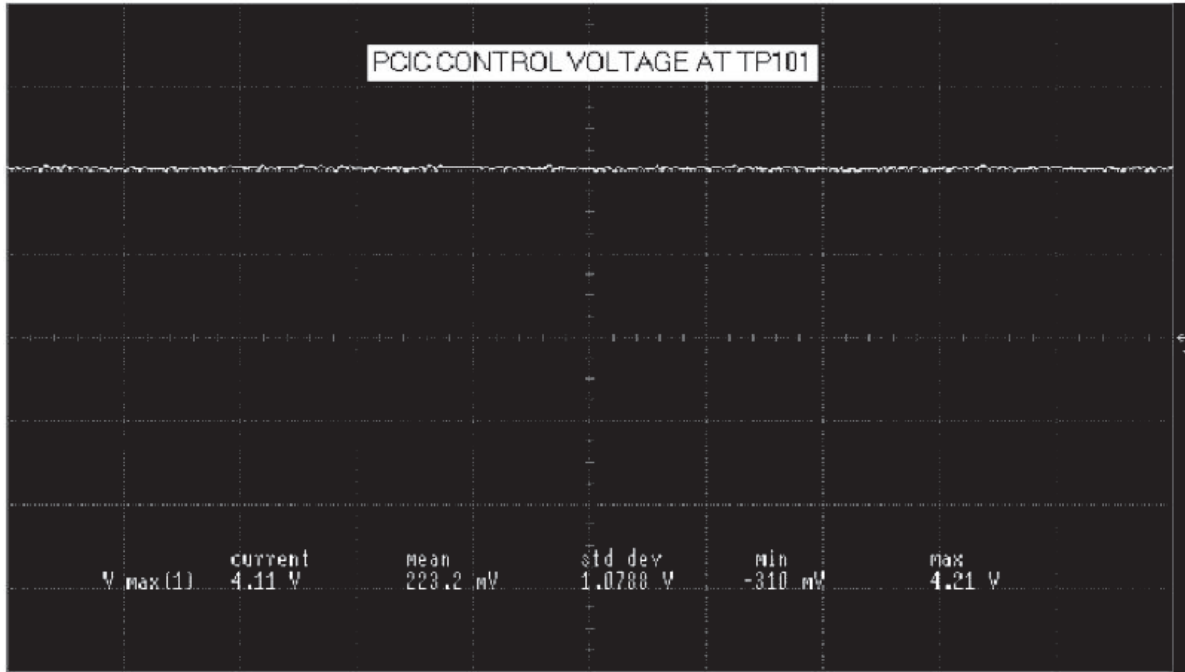

Test point: TP101.

7.5.11 PP7 TX LO

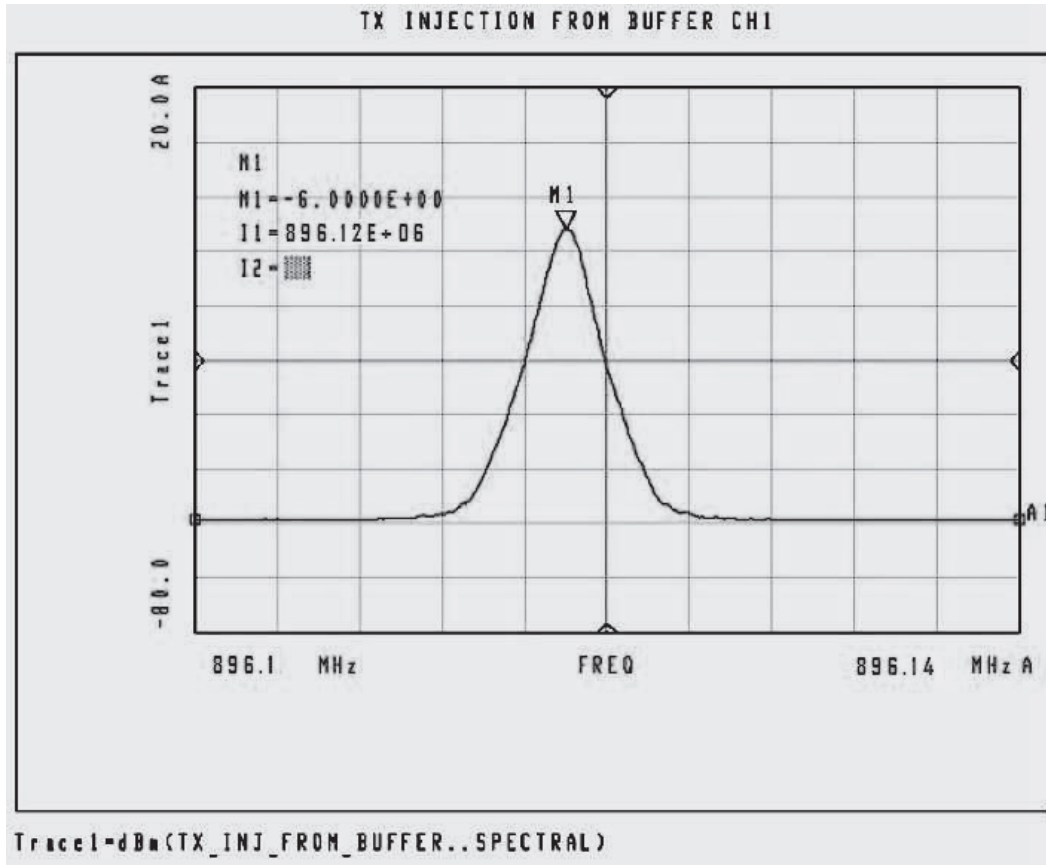

Probe point: Shield Tx_INJ.

7.5.12 PP8 Higher Level Voltage Multiplier

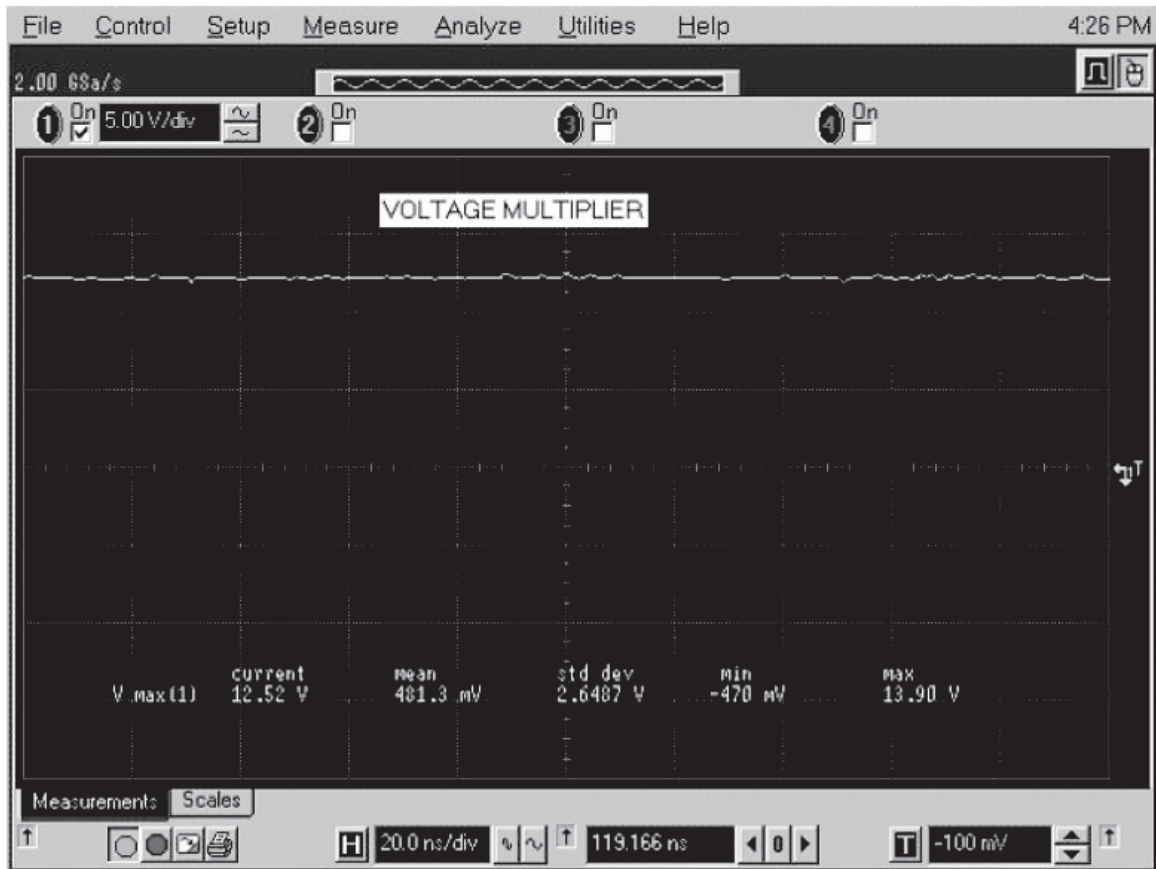

Probe point: C207 (located under shield).

7.5.13 PP9 Superfilter Output

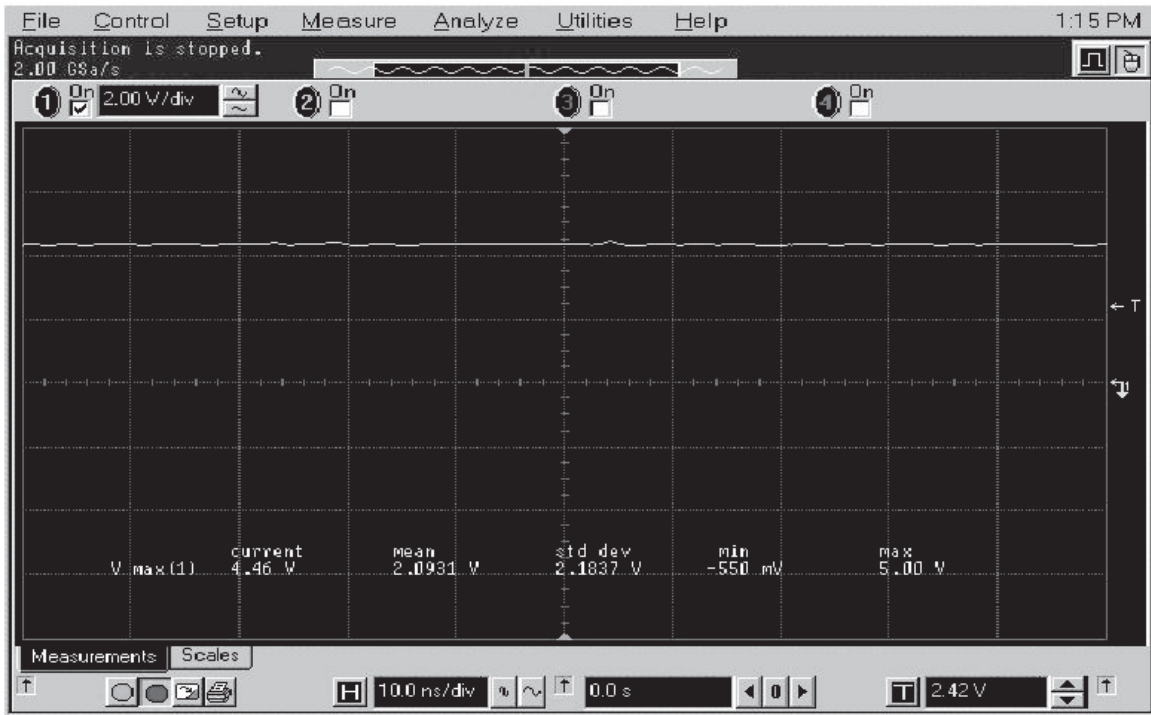

Probe point: C240 (located under shield).

7.5.14 TP10 TRB

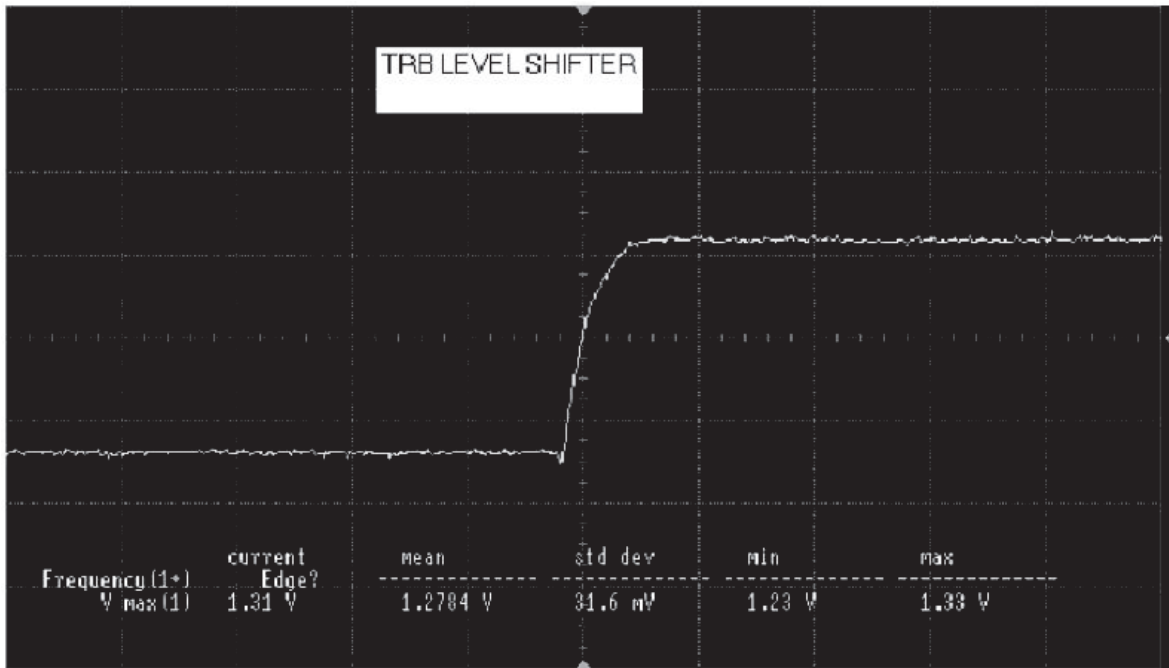

Test point: TP001.

Signal shows transition between RX mode (low) and TX mode (high).

7.5.15 PP11 Prescalar Input to FracN Synthesizer

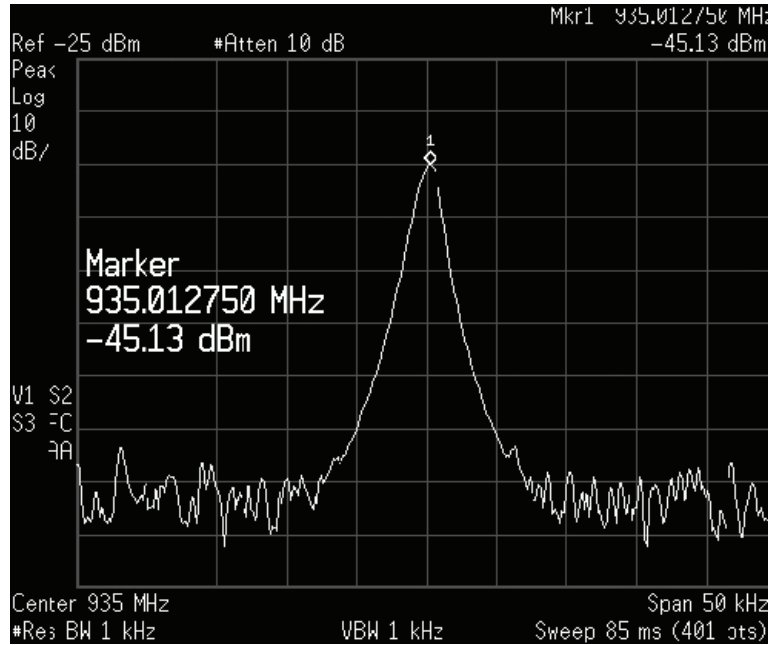

Prescalar Input for TX/RX 935.0125MHz

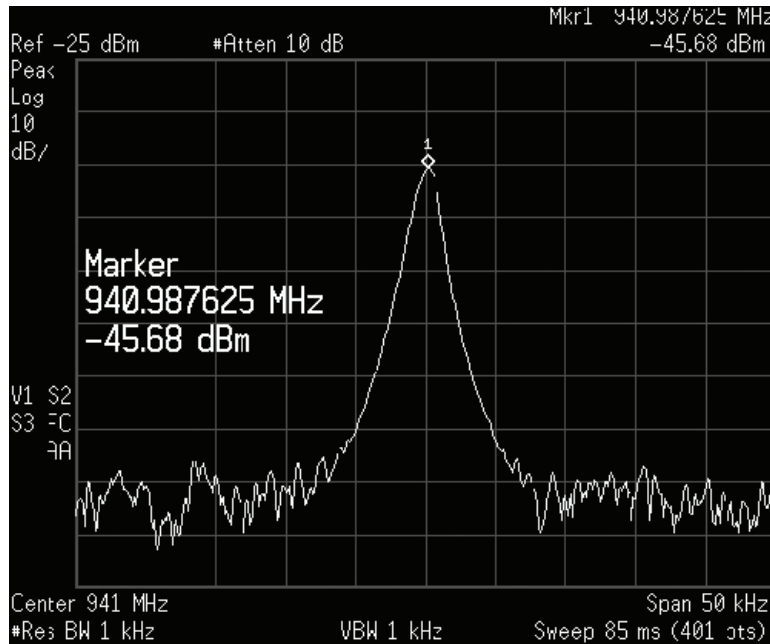

Prescalar Input for TX/RX 940.9875MHz

Probe point: C236 (located under shield).

7.5.16 PP12 Reference Crystal Output

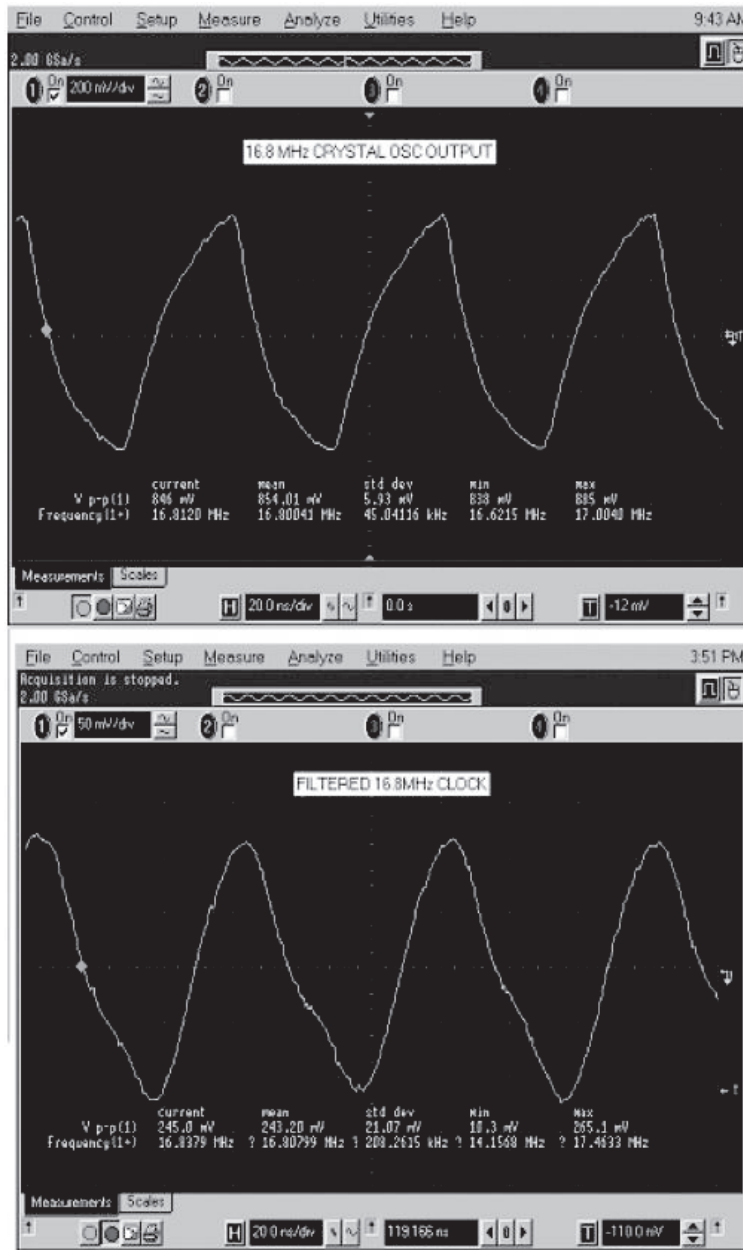

Probe point: R243, C293.

Crystal output AC coupled. Peak-to-peak value is accurate.

7.5.17 TP13 Mod In

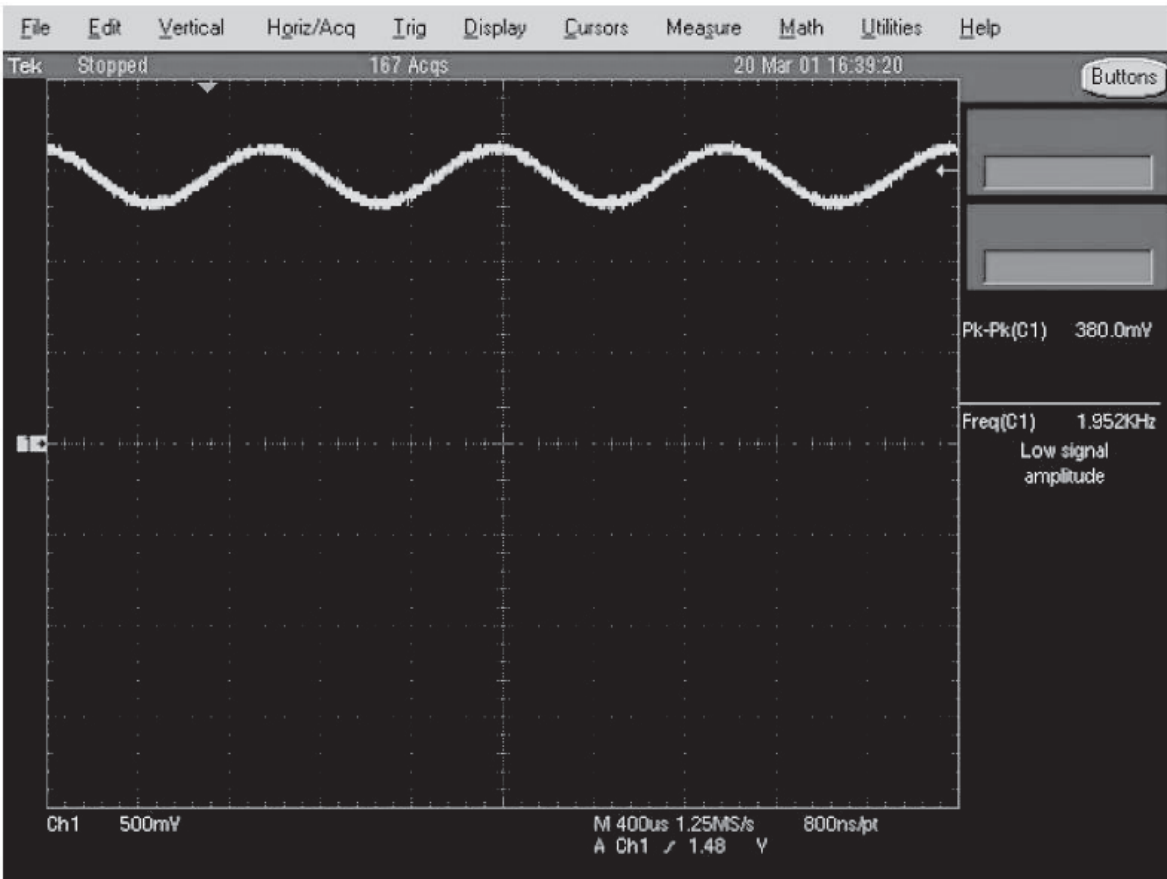

Test point: TP203.

7.5.18 TP14 1st LO Control Voltage

Typical value when tuned to receive at 935.0625 MHz.

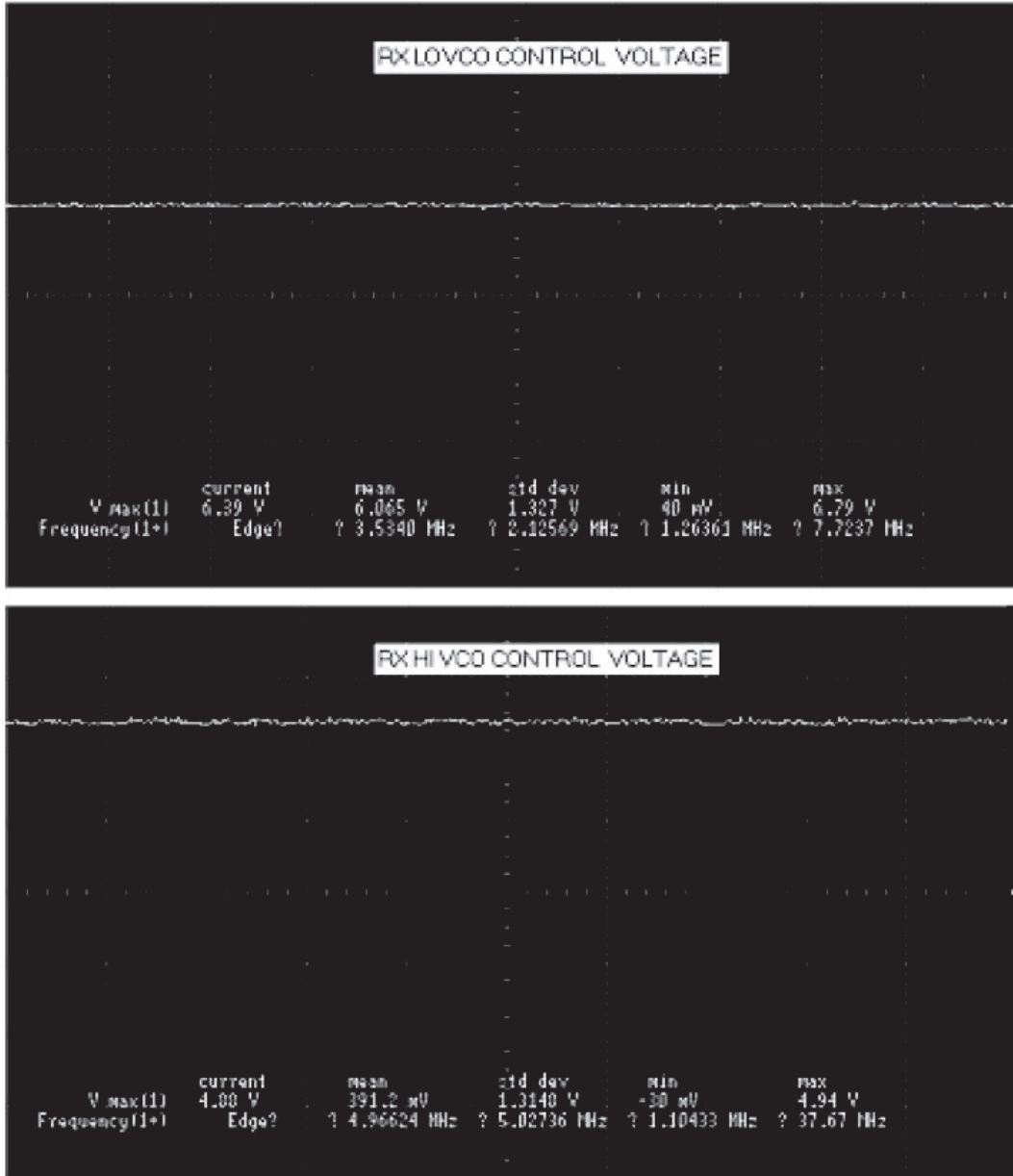

Typical value when tuned to receive at 940.9875 MHz.

Test point TP202

7.5.19 PP15 VCO Output

RX VCO LOW Injection

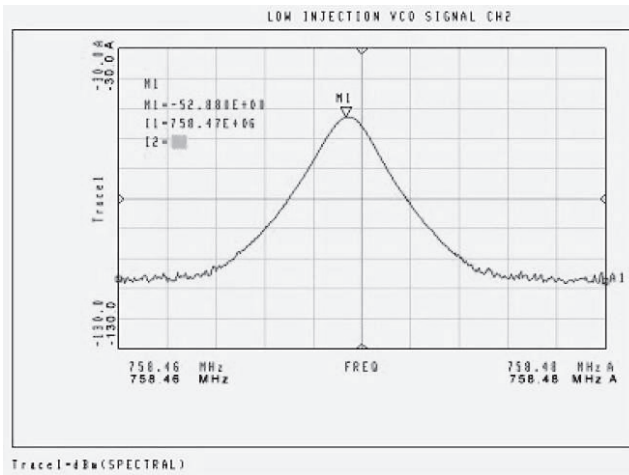
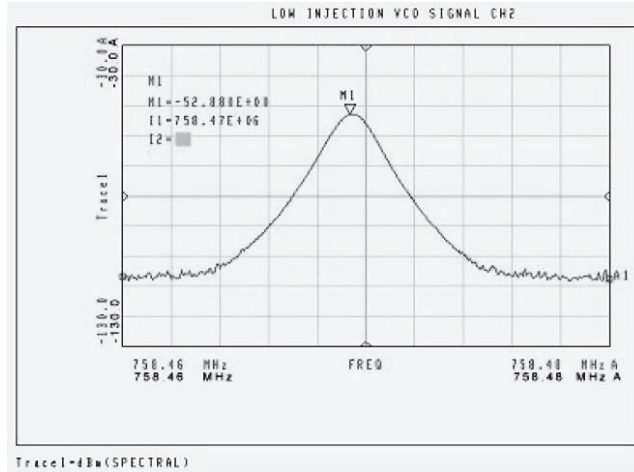

TX VCO

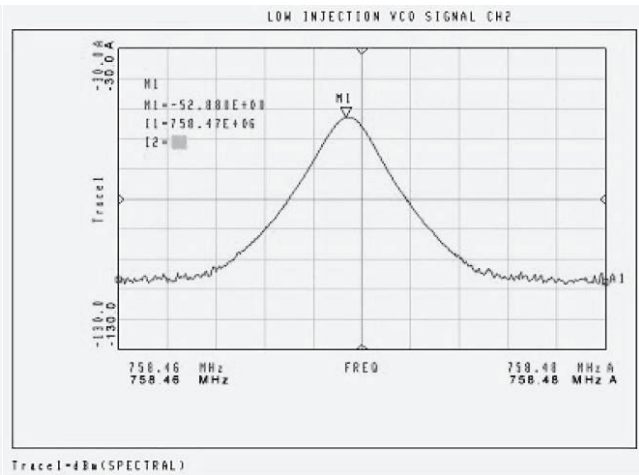

RX VCO HIGH Injection

Probe point: C261 for LO Output (located under shield)
C266 for TX Output (located under shield)
C236 for Preselector Output (located under shield).

7.5.20 PP16 VCO RX LO

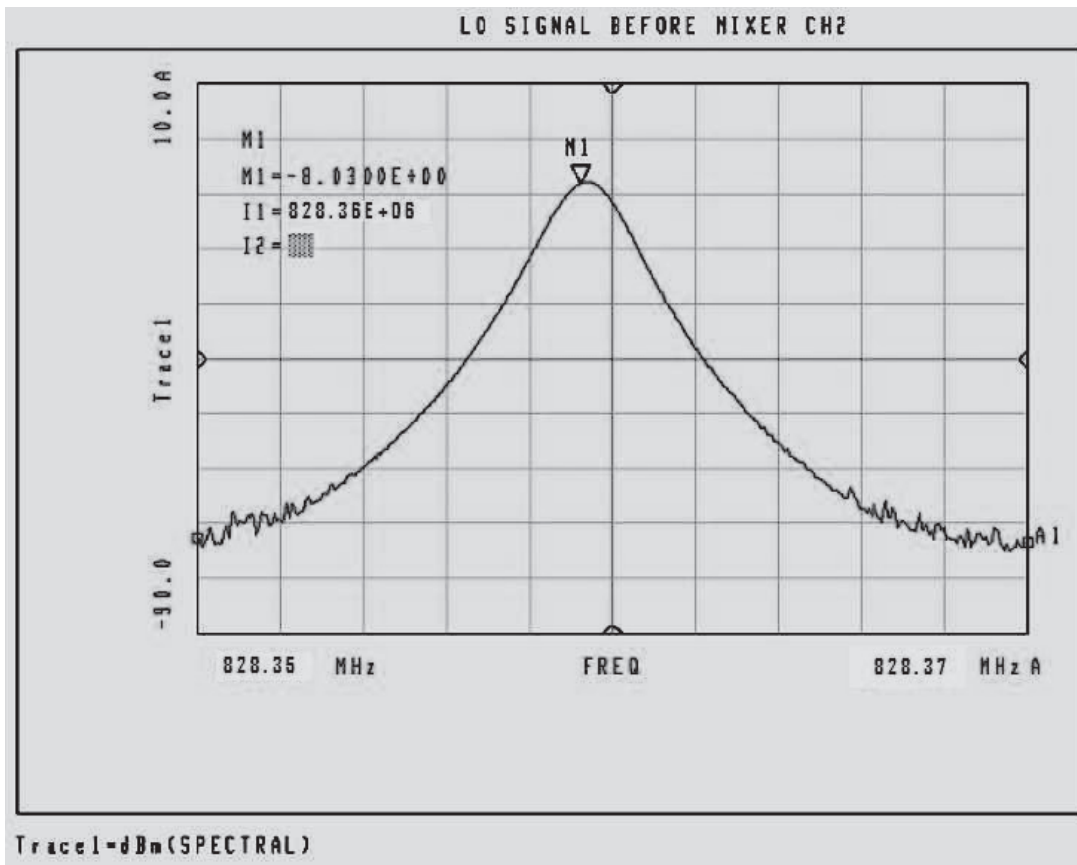

Probe point: C261 (located under shield).

7.5.21 PP17 Frequency Out (16.8 MHz)

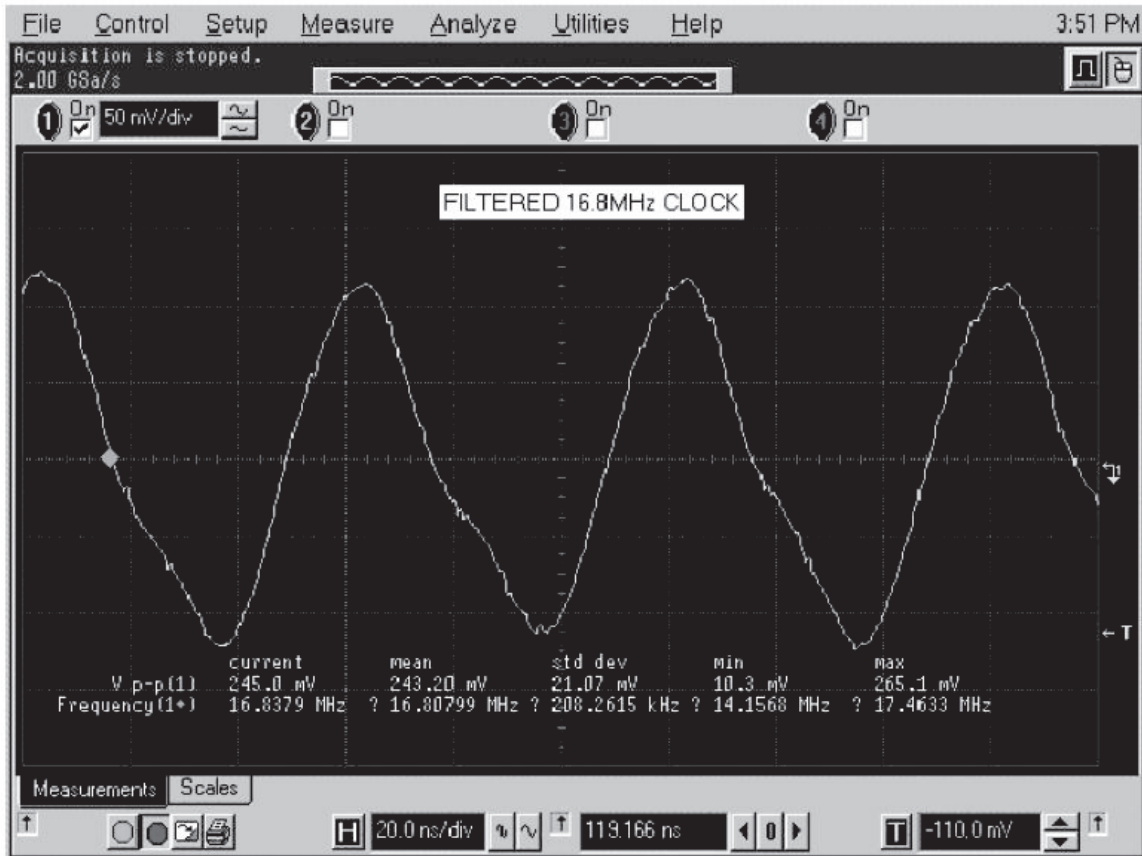

Probe point: Shield C293.

7.5.22 PP18 RX RF Input at Antenna Switch

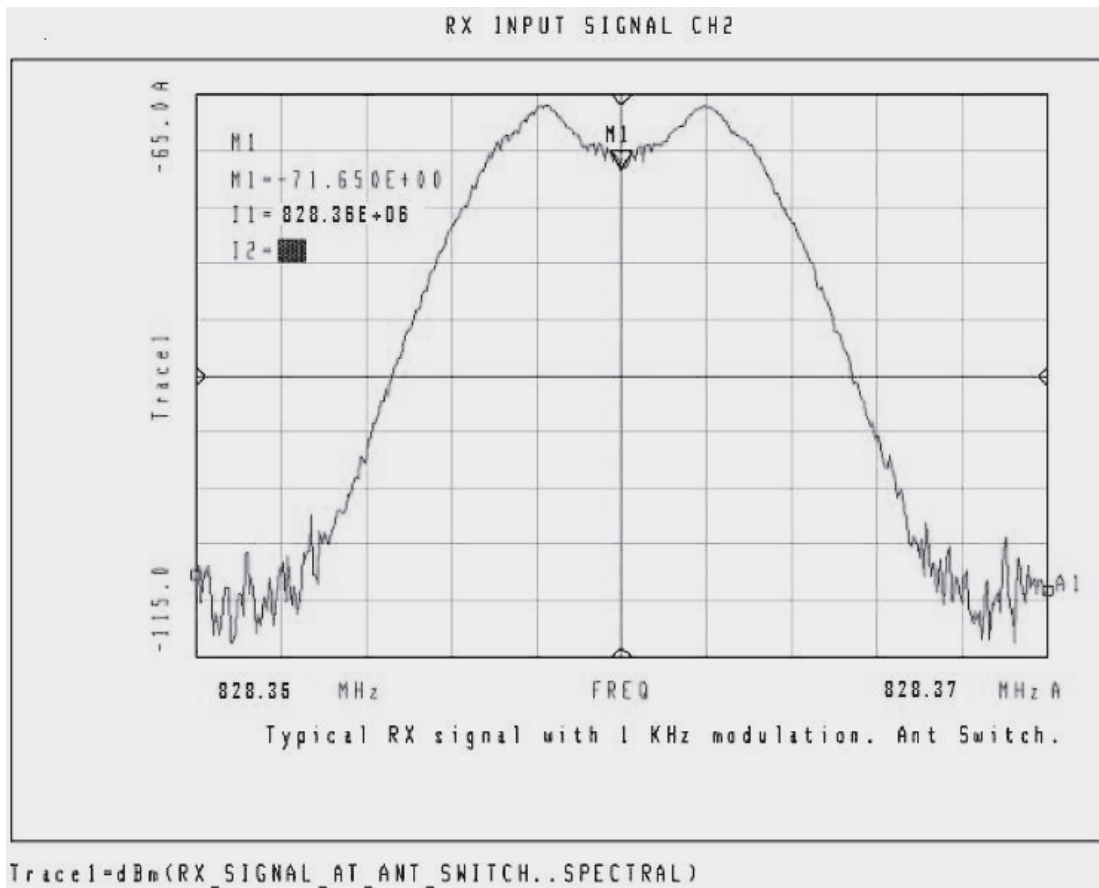

Probe point: FL1, pin 1.

Typical RX signal with 1 kHz modulation. Display shows modulation components of carrier.

7.5.23 PP19 Antenna Switch Bias

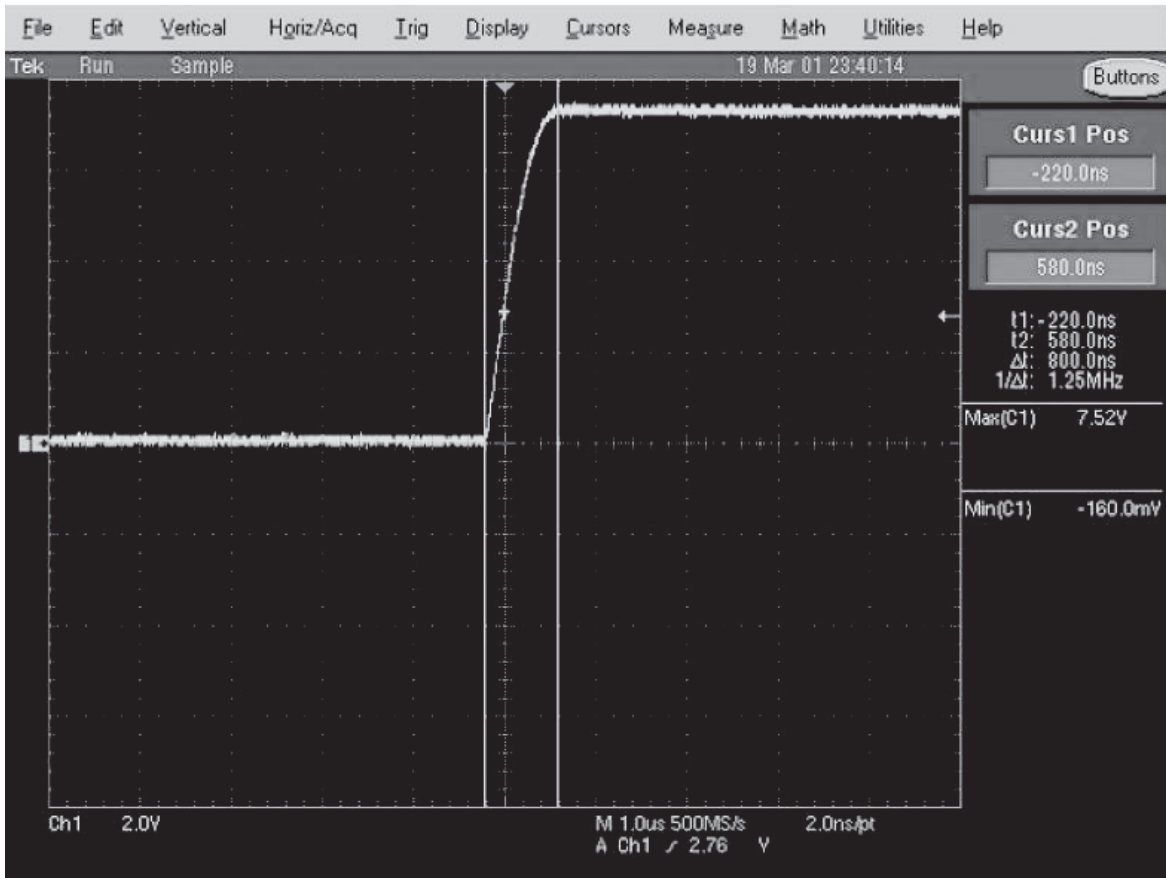

Probe point: U103, pin 1.

Display shows transition between RX mode (low) and TX mode (high).

7.5.24 PP20 Preselector Tuning Voltage

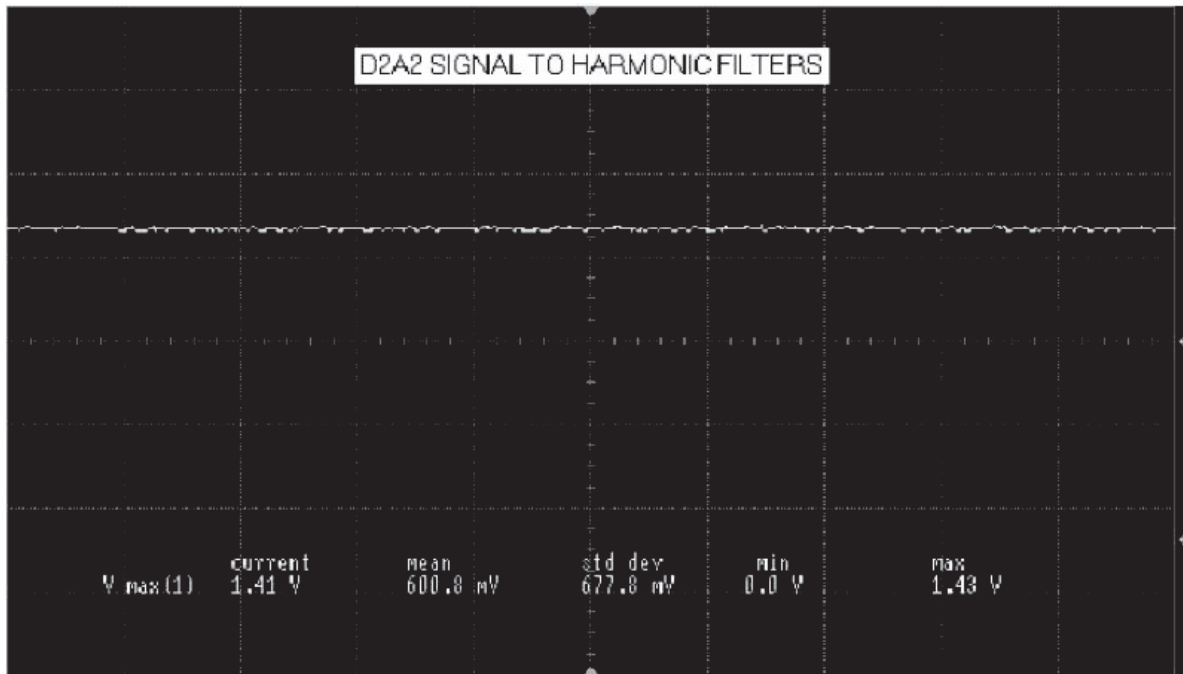

Probe point: FL1, pin 3; FL2, pin 3.

This is a typical value when tuned to receive at 935.0625 MHz.

7.5.25 PP21 RX RF Input after Antenna Switch

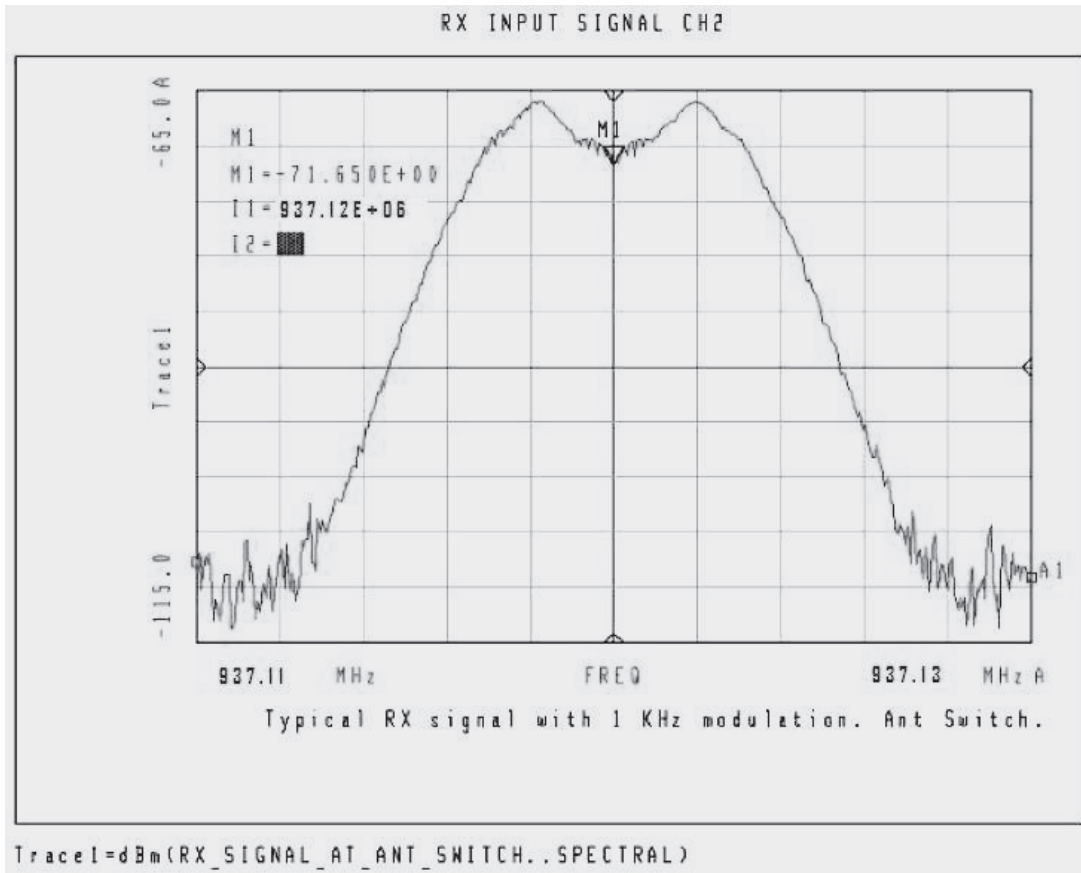

Probe point: FL1, pin 1.

7.5.26 PP22 Analog 5V

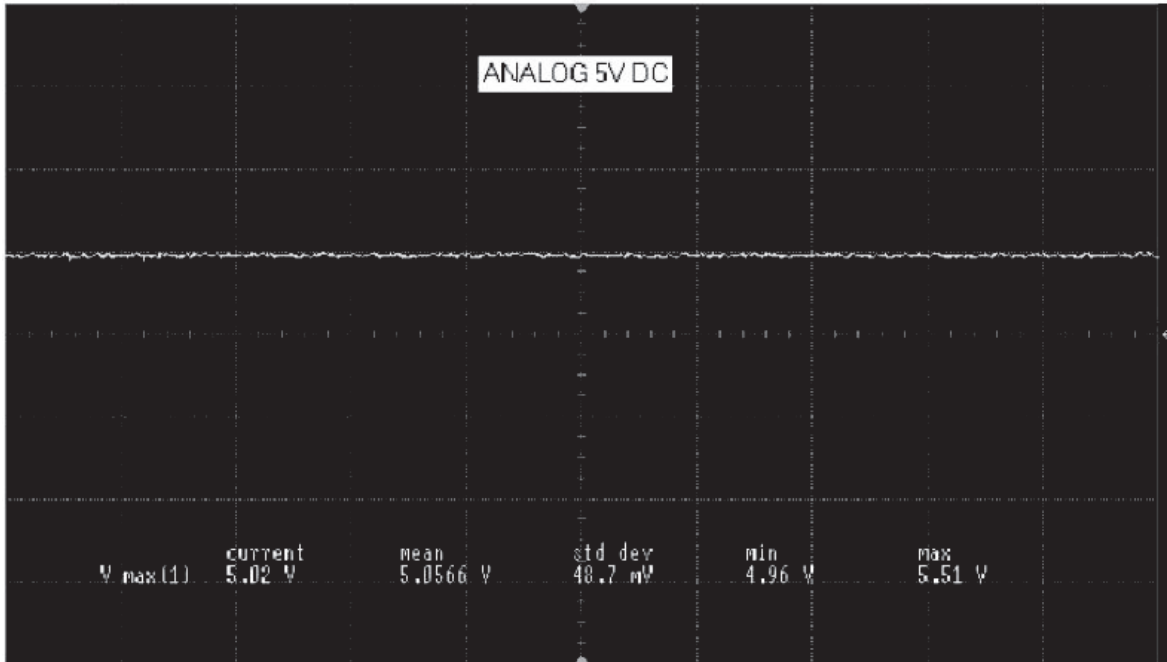

Probe point: U500, pin 5.

7.5.27 PP23 Preselector 1 Output

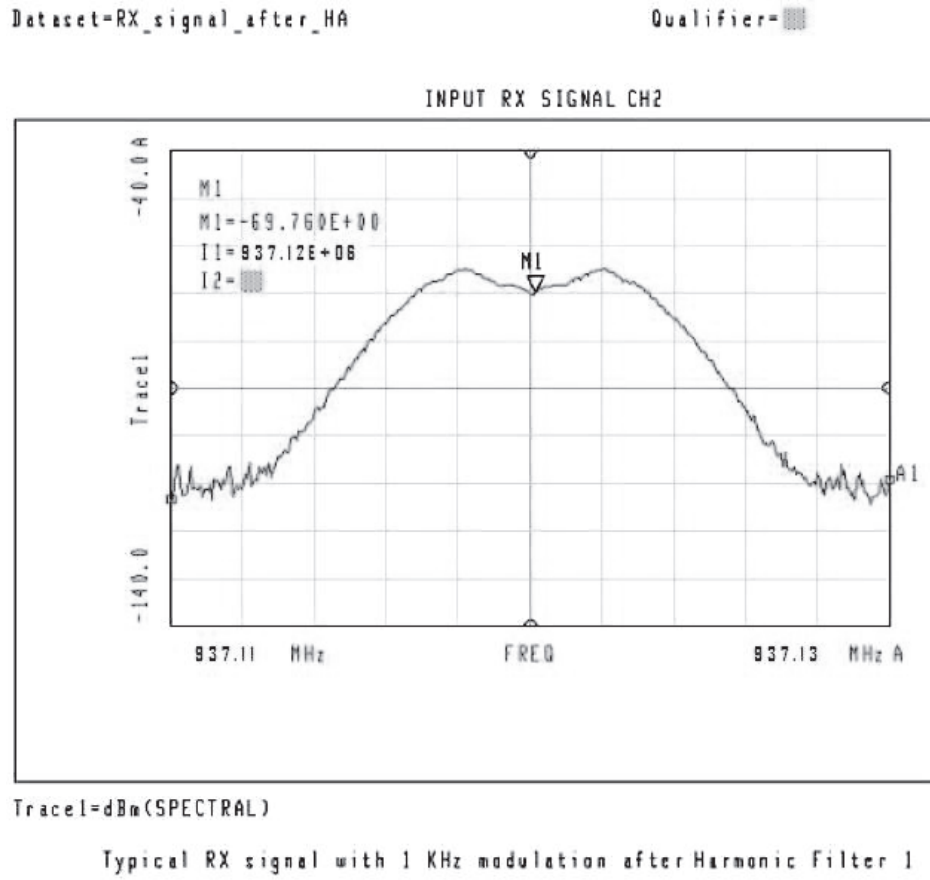

Probe point: FL1, pin 2.

Typical RX signal with 1 kHz modulation. Display shows modulation components of carrier.

7.5.28 PP24 Low-Noise Amplifier Output

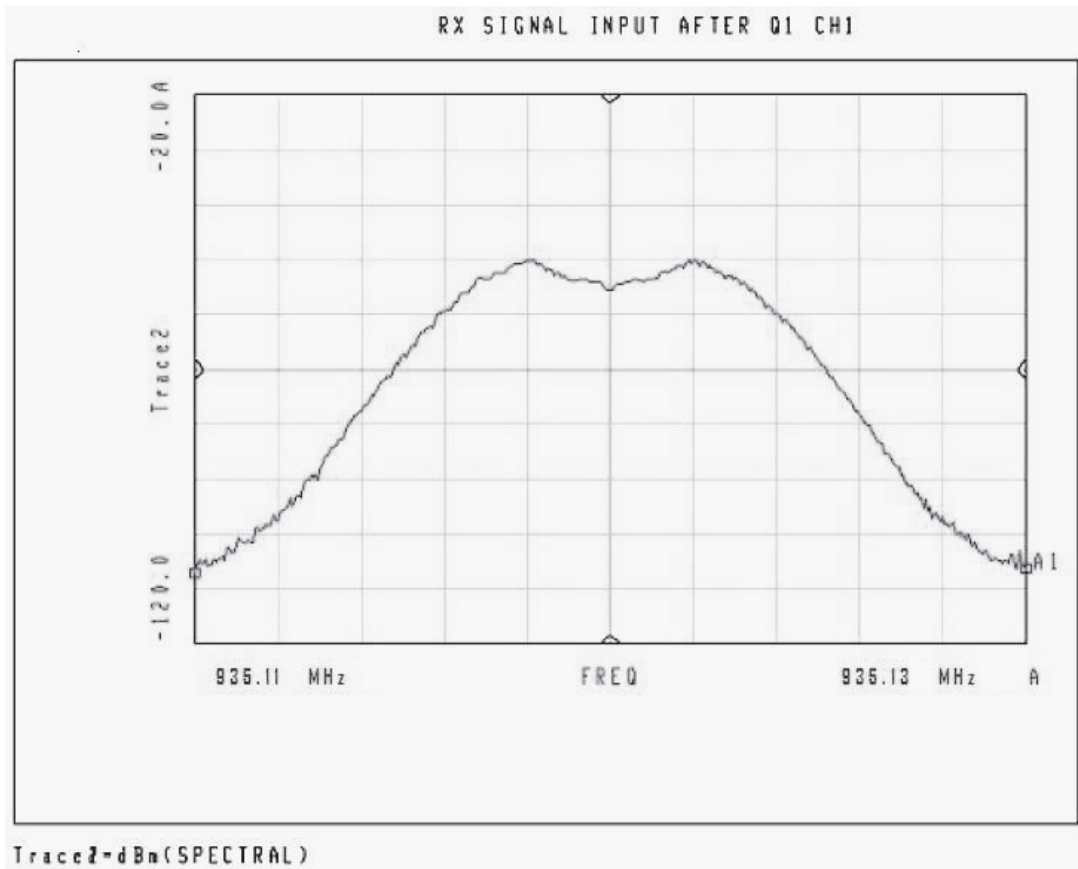

Probe point: FL2, pin 1.

Typical RX signal with 1 kHz modulation. Display shows modulation components of carrier.

7.5.29 PP25 Preselector 2 Output

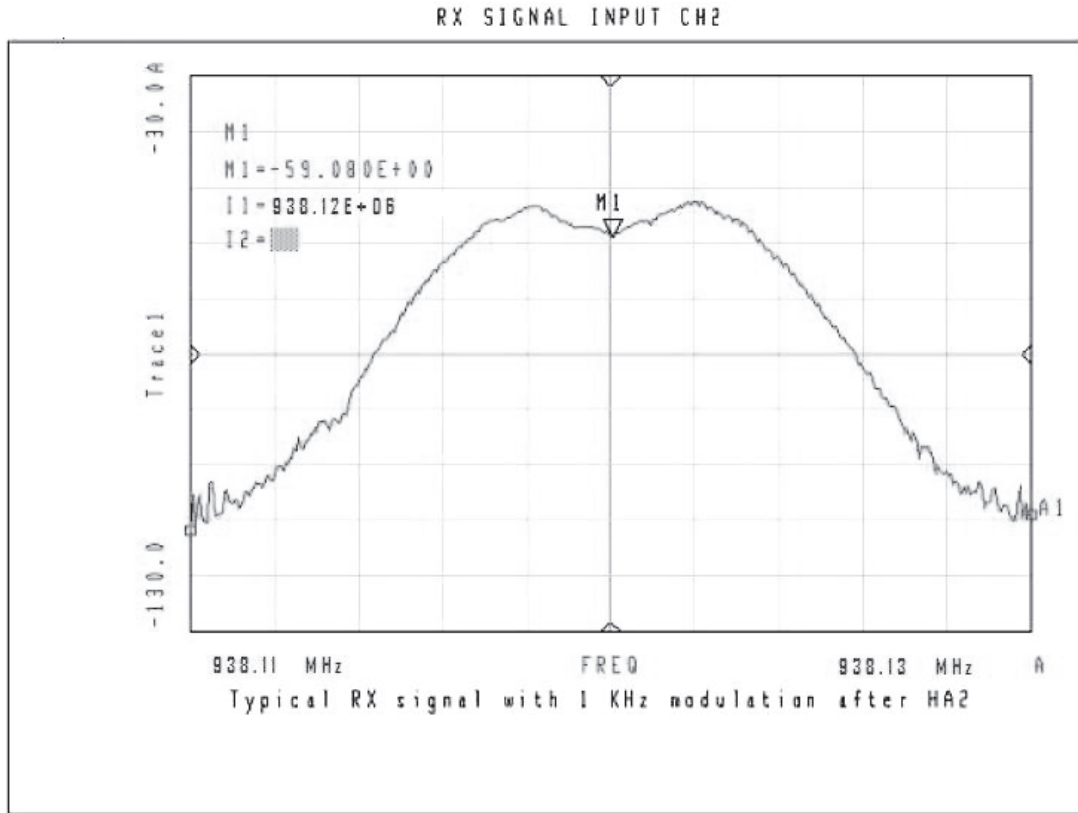

Trace1=dBm(RX_SIGNAL_AFTER_HA2..SPECTRAL)

Probe point: FL2, pin 2.

Typical RX signal with 1 kHz modulation. Display shows modulation components of carrier.

7.5.30 PP26 Mixer Out (IF)

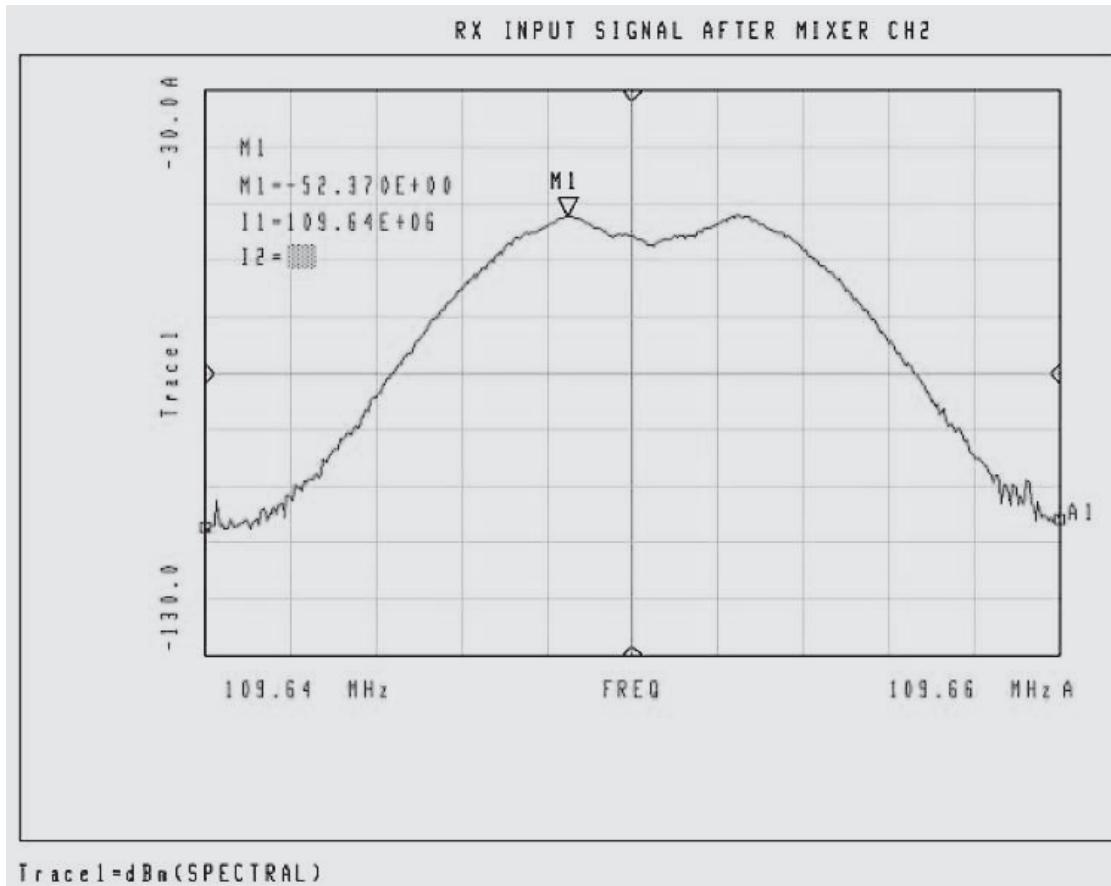

Probe point: L10.

Typical RX signal with 1 kHz modulation. Display shows modulation components of carrier.

7.5.31 PP27 Crystal Filter Out

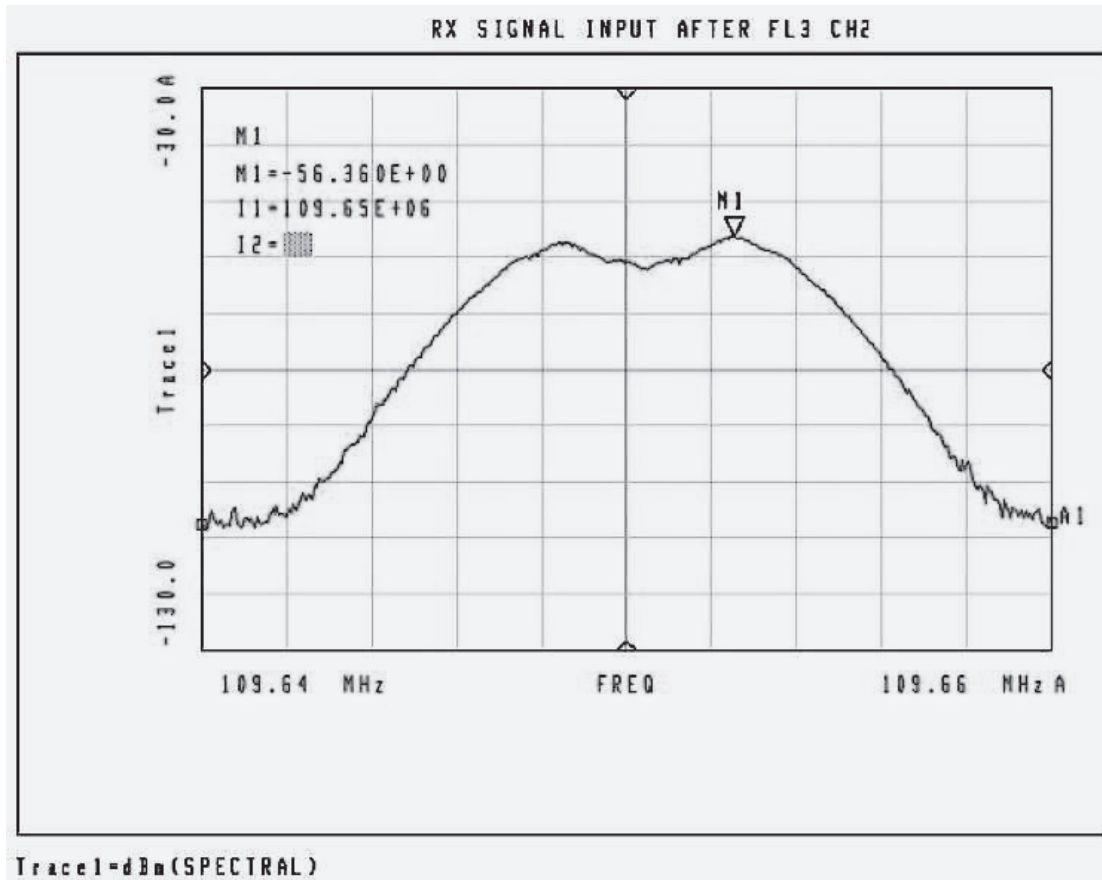

Probe point: C413.

7.5.32 PP28 Abacus Analog 3V

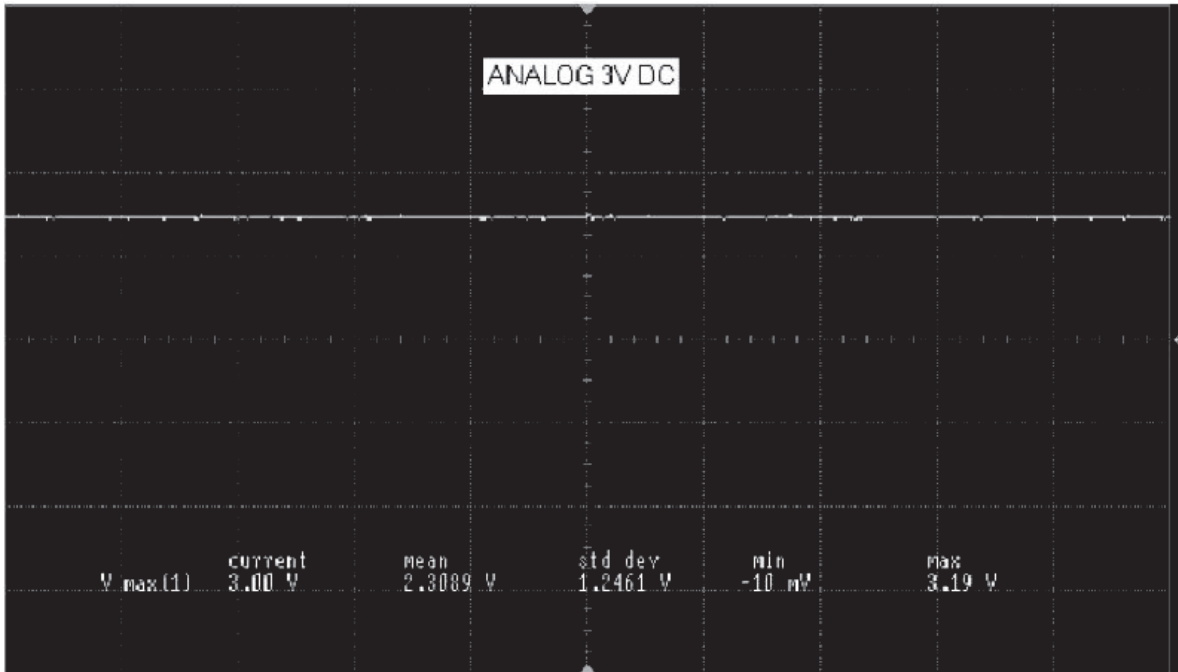

Probe point: U501, pin 5.

7.5.33 PP29 2nd LO Control Voltage

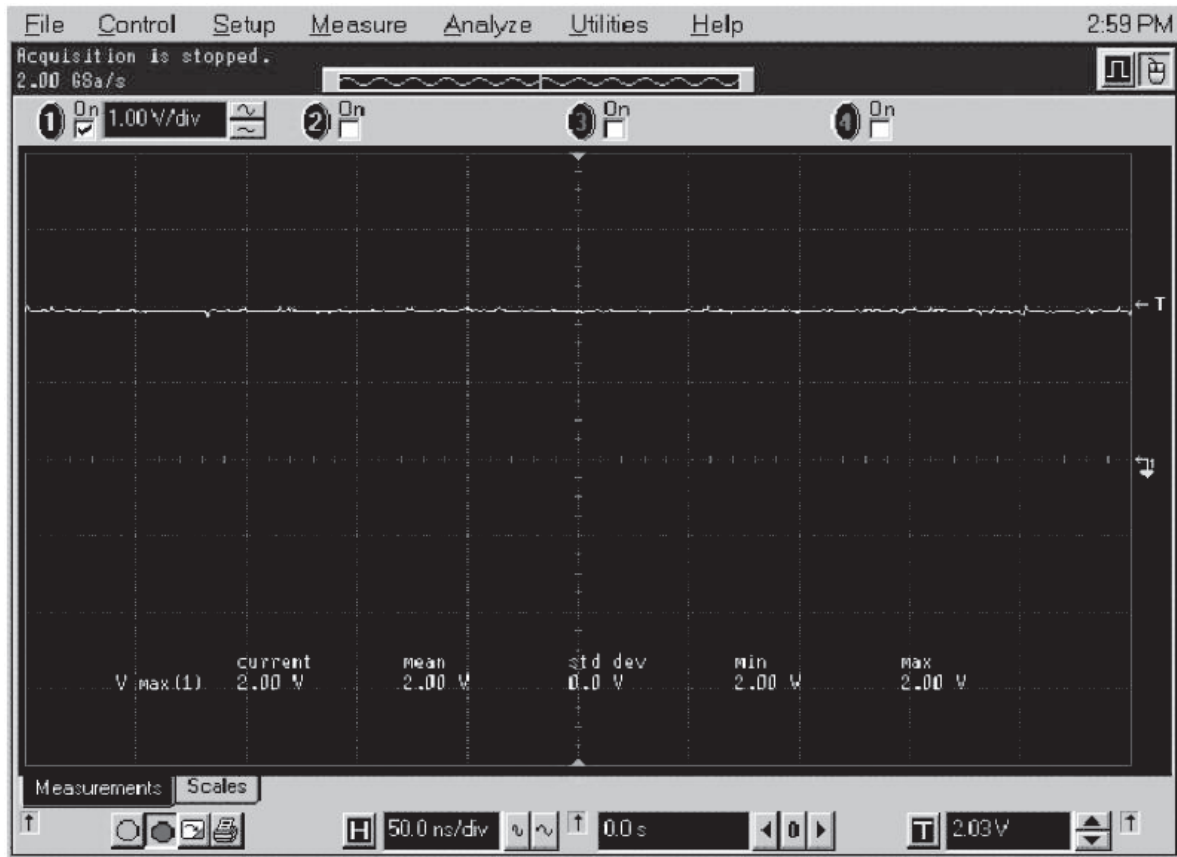

Probe point: U401, pin 38 (located under shield).

7.5.34 PP30 2nd LO VCO Buffer Output

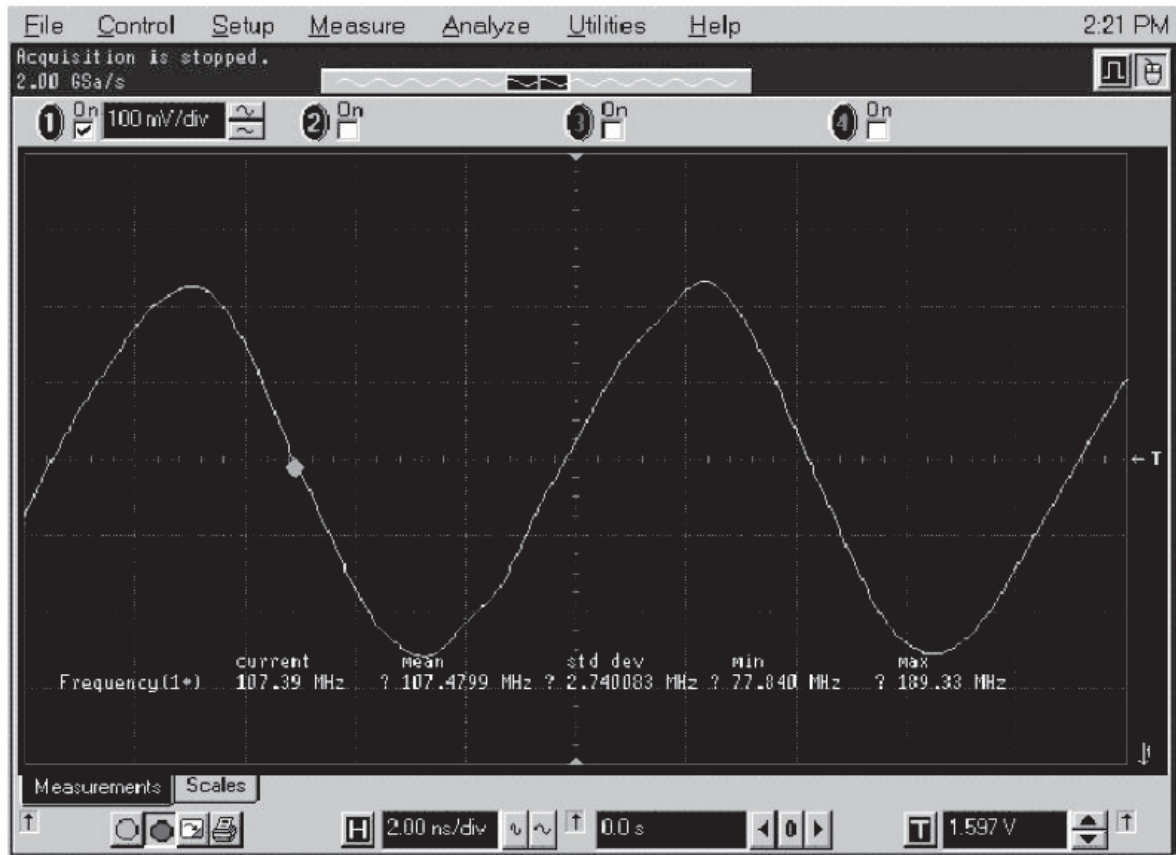

Probe point: Shield C407.

7.5.35 PP31 Analog 5V DC

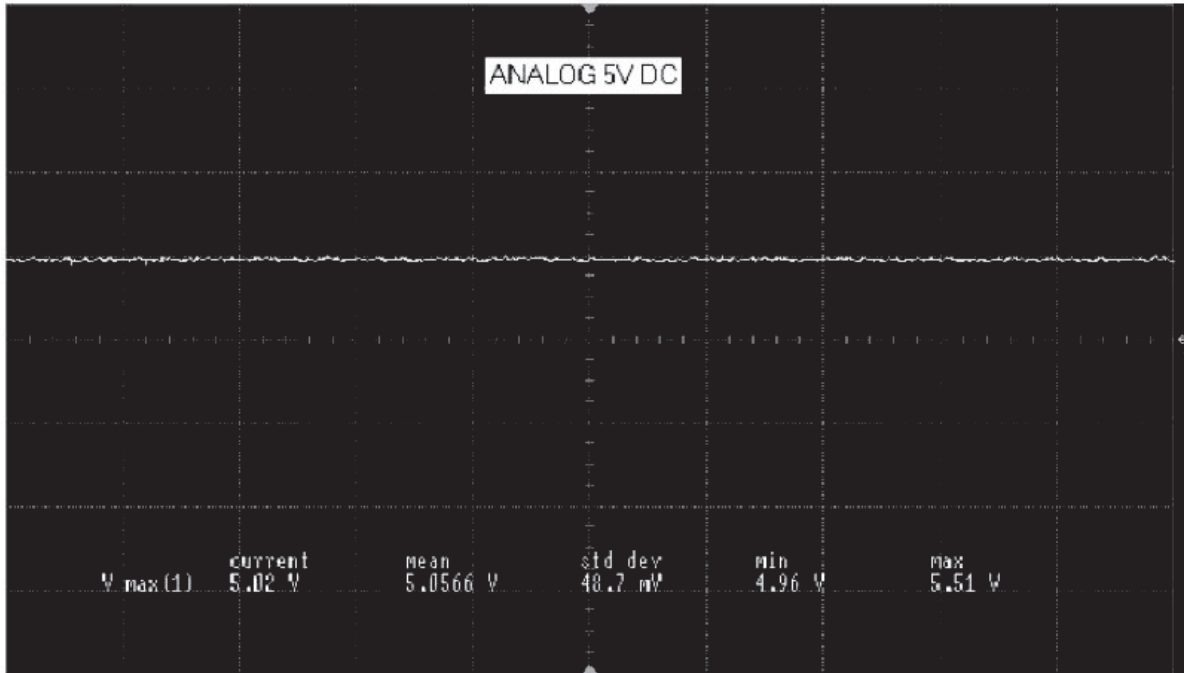

Probe point: U500, pin 5.

7.5.36 PP32 Abacus Digital 3V

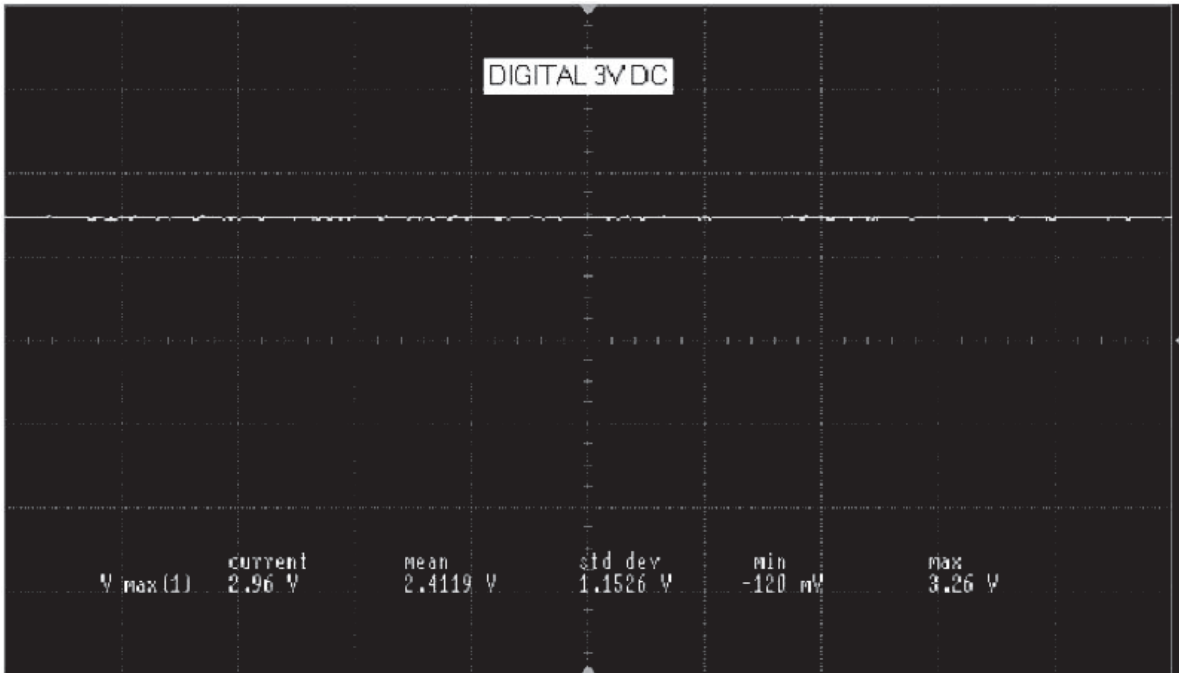

Probe point: U502, pin 5.

7.5.37 TX Audio 1 kHz Tone

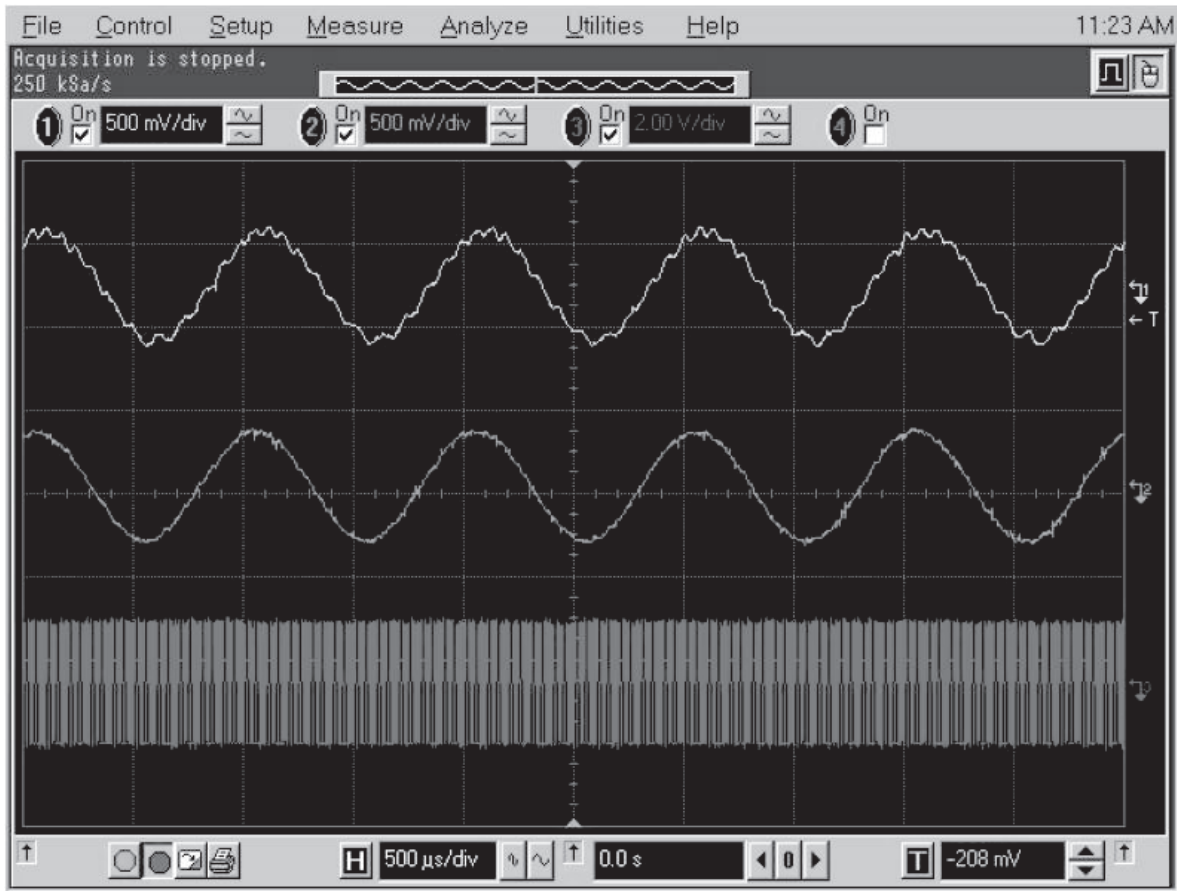

Trace 1: TP203 Mod In (640 mVp-p 1 kHz tone 1.5 Vdc)

Trace 2: U202, pin 1 (620 mVp-p 1 kHz tone)

Trace 3: FL200, pin 8 (1.2 MHz square wave 0 to 3 V)

Note: Transmit audio 1 kHz tone, which provides 3 kHz deviation.

7.5.38 16.8 MHz Buffer Input and Output

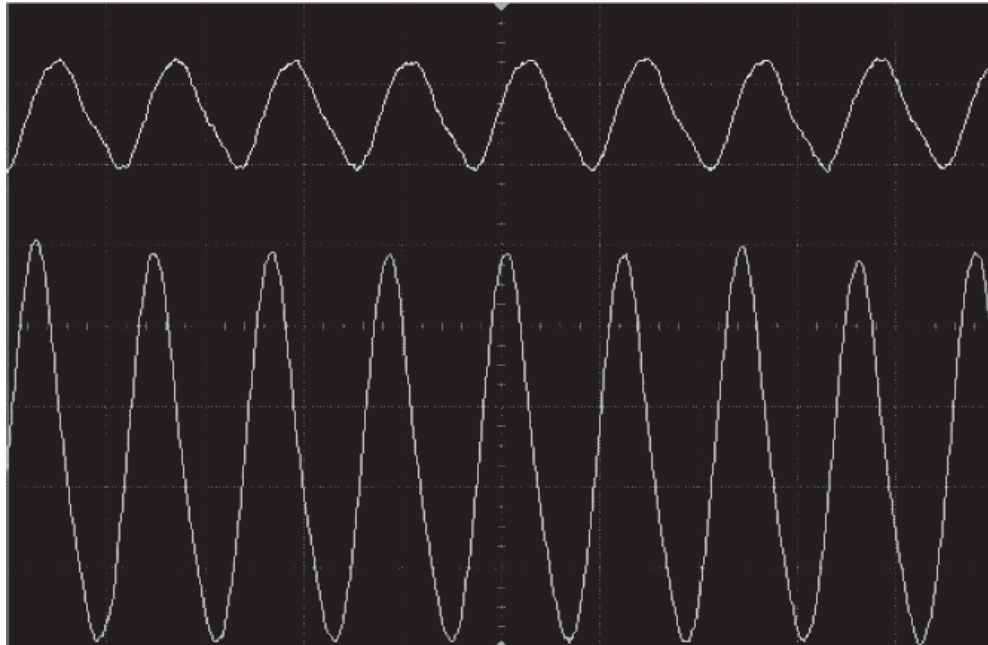

Acquisition	Sampling mode real time Configuration 4GSa/s Memory depth automatic Memory depth 1004pts Sampling rate automatic Sampling rate 2.00 GSa/s Averaging off 9-bit BW Filter off Interpolation on
Channel 1	Scale 200 nV/div Offset 644 mV Coupling DC Impedance 1M Ohm Attenuation 10.00 : 1 Atten units ratio Skew 0.0 s Ext adapter None Ext coupler None Ext gain 1.00E+00 Ext offset 0.0E+00
Channel 2	Scale 200 nV/div Offset 913 mV Coupling DC Impedance 1M Ohm Attenuation 10.00 : 1 Atten units ratio Skew 0.0 s Ext adapter None Ext coupler None Ext gain 1.00E+00 Ext offset 0.0E+00
Time base	Scale 50.0 ns/div Position 0.0 s Reference center
Trigger	Mode edge Sweep auto Hysteresis normal Holdoff time 60 ns Coupling DC Source channel 1 Trigger level 1.168 V Slope rising

Trace 1: Buffer input at R729.
Trace 2: Buffer output at C726.

Note: There should be no voltage gain between the Buffer's input and output. The 16.8MHz clock should be an approximately 1V peak-to-peak sine wave.

7.5.39 32.768 kHz Clock Outputs

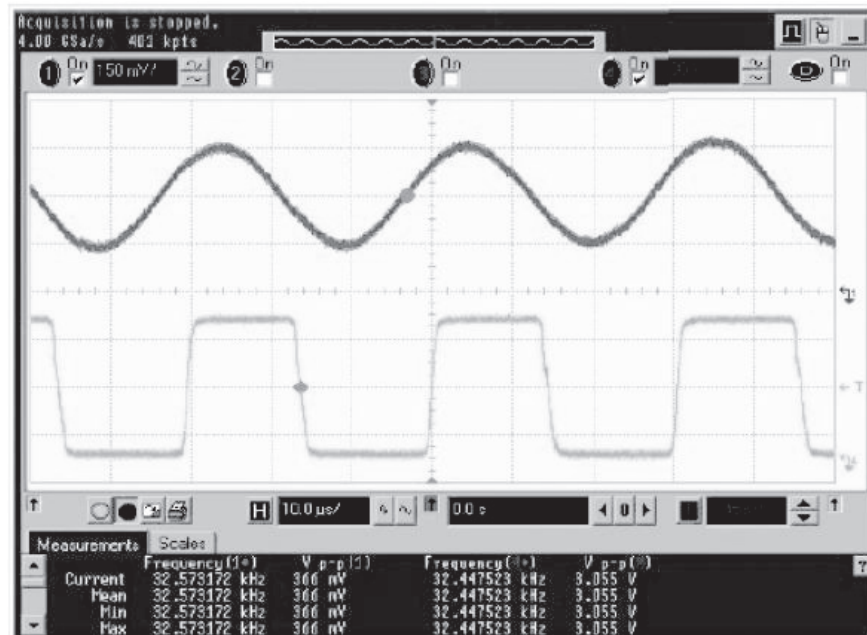

Trace 1: Output at C743.

Trace 2: Output at U712, pin 4.

7.5.40 SPI B Data

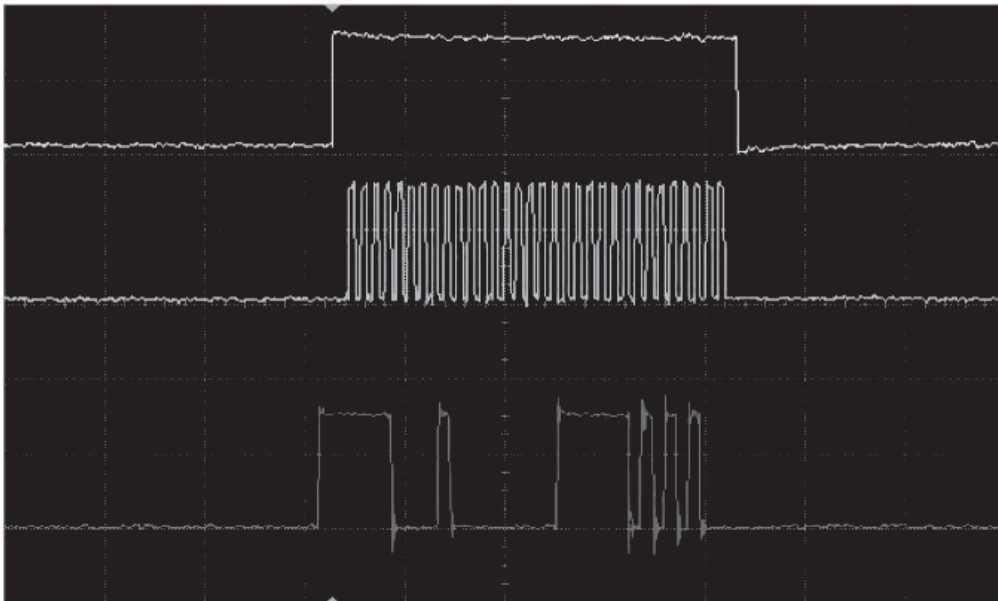

Acquisition Sampling mode real time Configuration 4GSa/s
 Memory depth automatic Memory depth 1004pts
 Sampling rate automatic Sampling rate 50 MSa/s
 Averaging off
 9-bit BW Filter off Interpolation on

Channel 1 Scale 1.99 V/div Offset -4.21 V Coupling DC Impedance 1M Ohm
 Attenuation 10.00 : 1 Atten units ratio Skew 0.0 s
 Ext adapter None Ext coupler None
 Ext gain 1.00E+00 Ext offset 0.0E+00

Channel 2 Scale 2.00 V/div Offset -260 mV Coupling DC Impedance 1M Ohm
 Attenuation 10.00 : 1 Atten units ratio Skew 0.0 s
 Ext adapter None Ext coupler None
 Ext gain 1.00E+00 Ext offset 0.0E+00

Channel 3 Scale 2.00 V/div Offset -5.76 V Coupling DC Impedance 1M Ohm
 Attenuation 10.00 : 1 Atten units ratio Skew 0.0 s
 Ext adapter None Ext coupler None
 Ext gain 1.00E+00 Ext offset 0.0E+00

Time base Scale 2.00 μ s/div Position 3.454546 μ s Reference center

Trigger Mode edge Sweep auto
 Hysteresis normal Holdoff time 60 ns Coupling DC
 Source channel 1 Trigger level 810 mV Slope rising

Trace 1: MAKO chip enable, R767 (not active high)
Trace 2: SPI data clock, C619
Trace 3: SPI data to MAKO, C617.

7.5.41 RX Serial Audio Port (SAP)

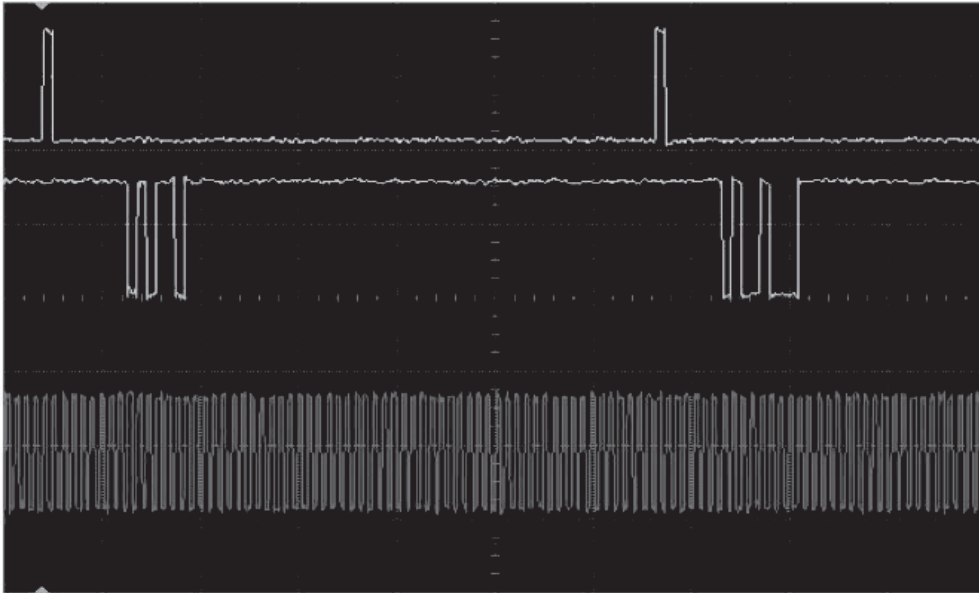

Acquisition	Sampling mode real time Configuration 4GSa/s Memory depth automatic Memory depth 1004pts Sampling rate automatic Sampling rate 5.00 MSa/s Averaging off 9-bit BW Filter off Interpolation on
Channel 1	Scale 1.99 V/div Offset -4.21 V Coupling DC Impedance 1M Ohm Attenuation 10.00 : 1 Atten units ratio Skew 0.0 s Ext adapter None Ext coupler None Ext gain 1.00E+00 Ext offset 0.0E+00
Channel 2	Scale 2.00 V/div Offset -210 mV Coupling DC Impedance 1M Ohm Attenuation 10.00 : 1 Atten units ratio Skew 0.0 s Ext adapter None Ext coupler None Ext gain 1.00E+00 Ext offset 0.0E+00
Channel 3	Scale 2.00 V/div Offset -5.55 V Coupling DC Impedance 1M Ohm Attenuation 10.00 : 1 Atten units ratio Skew 0.0 s Ext adapter None Ext coupler None Ext gain 1.00E+00 Ext offset 0.0E+00
Time base	Scale 20.0 μ s/div Position 92.181816 μ s Reference center
Trigger	Mode edge Sweep auto

Note: TX is identical, except the data is probed at test point "TX".

Trace 1: 8 kHz frame sync (each word is 13 bits after falling edge of FSYNC)

Trace 2: SAP data at R626 (audio data from MAKO CODEC to Patriot DSP)

Note: Transmit is identical, except data acquired at R625

Trace 3: 512kHz bit clock at R616. (Codec_DCLK).

7.5.42 PP33 SPI Data

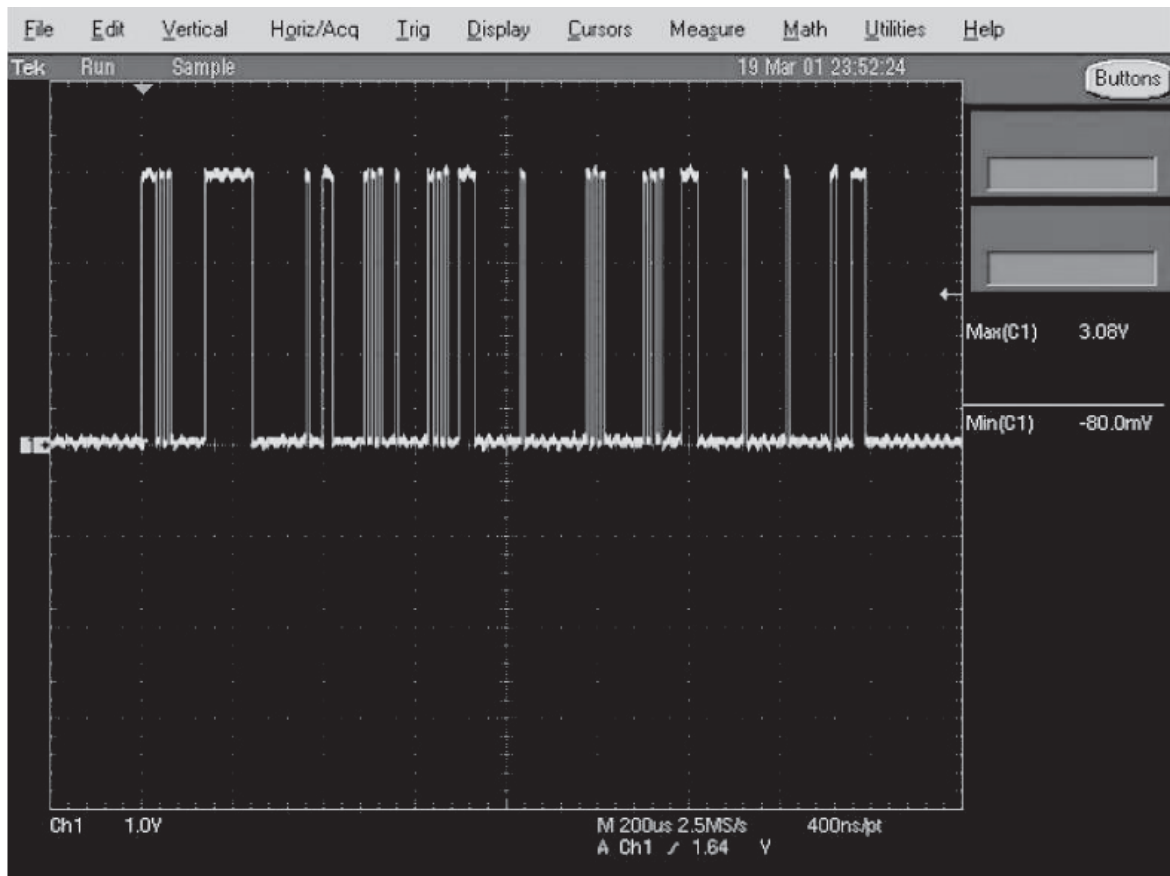

Probe Point: R802.

7.5.43 PP34 SPI CLK

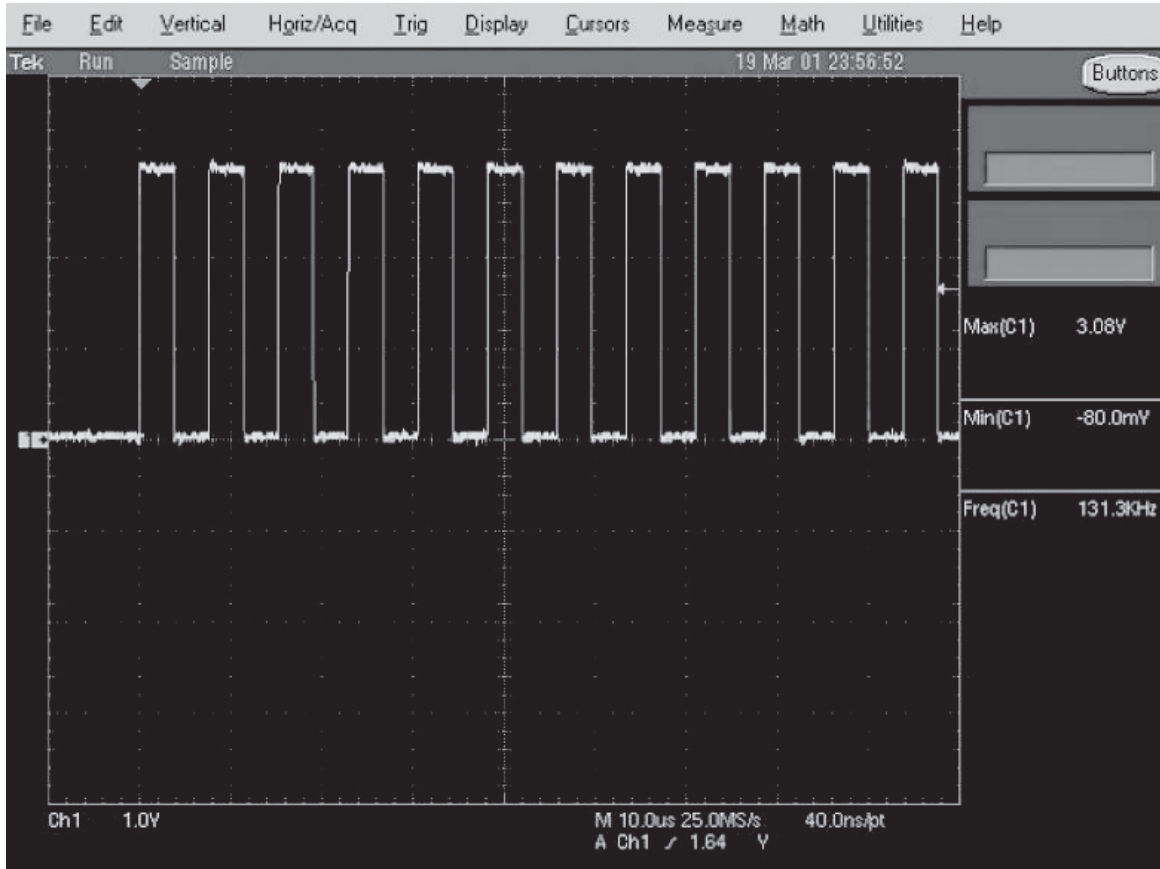

Probe Point: R803.

7.5.44 PP35 Universal Chip Select

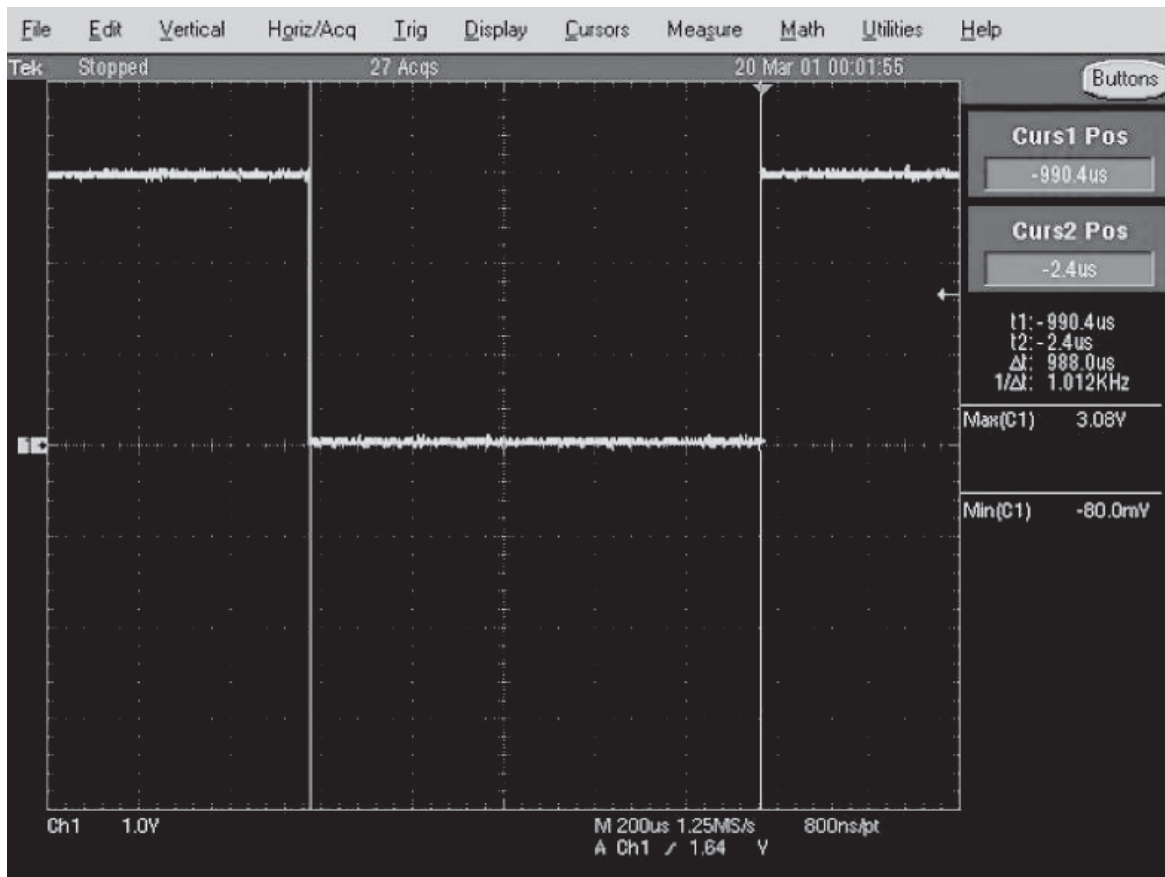

Probe Point: U102, pin 29 (located under shield).

7.5.45 PP36 Abacus Chip Select

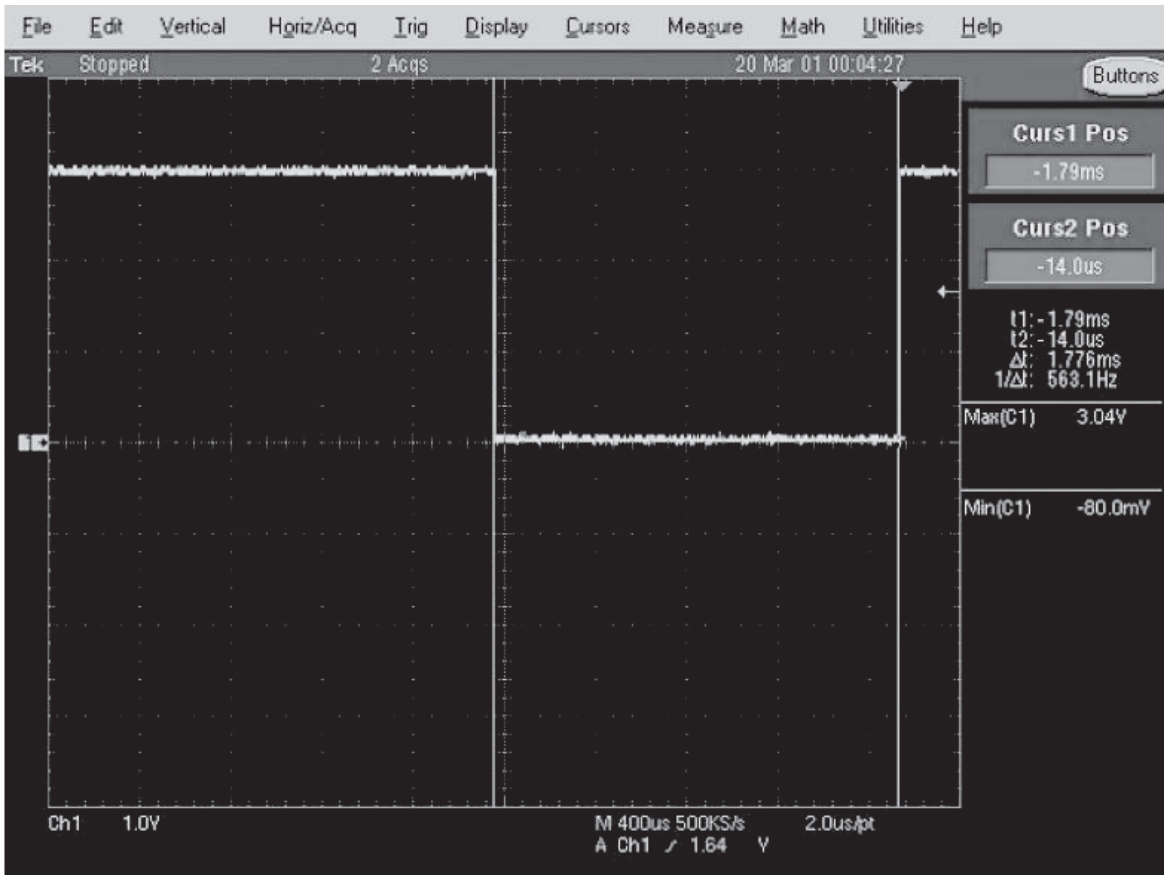

Probe Point: U401, pin 25 (located under shield).

7.5.46 TP37 RX SSI Data

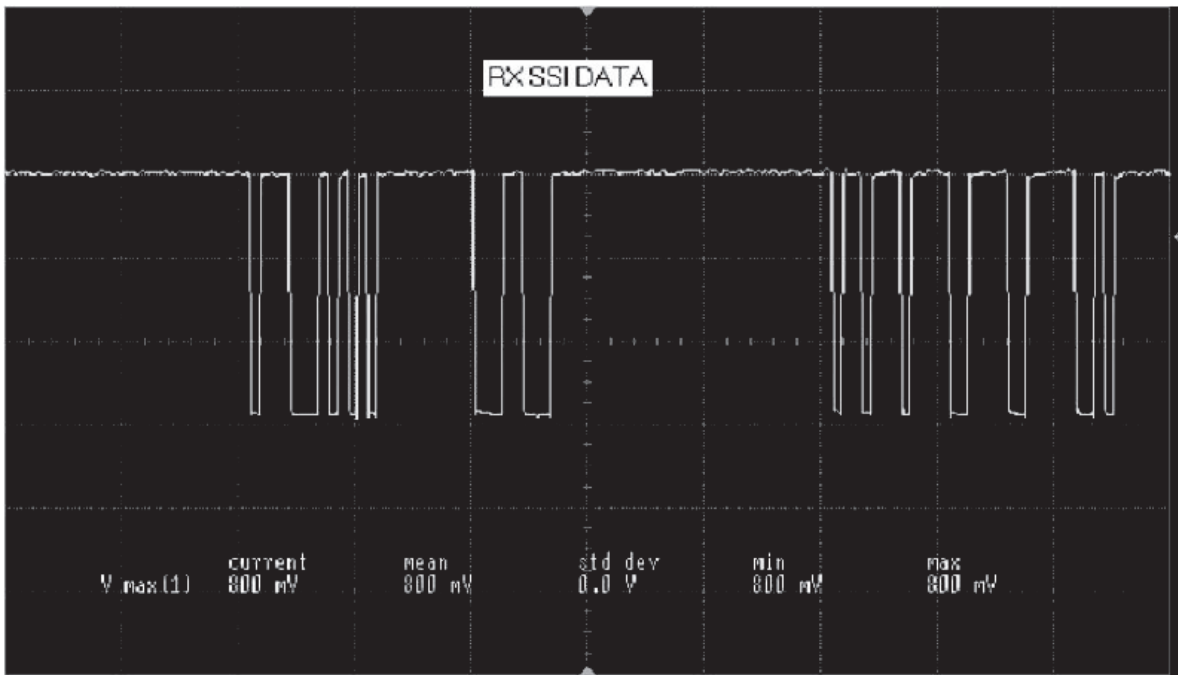

Test Point: TP403.

7.5.47 TP38 RX SSI Clock

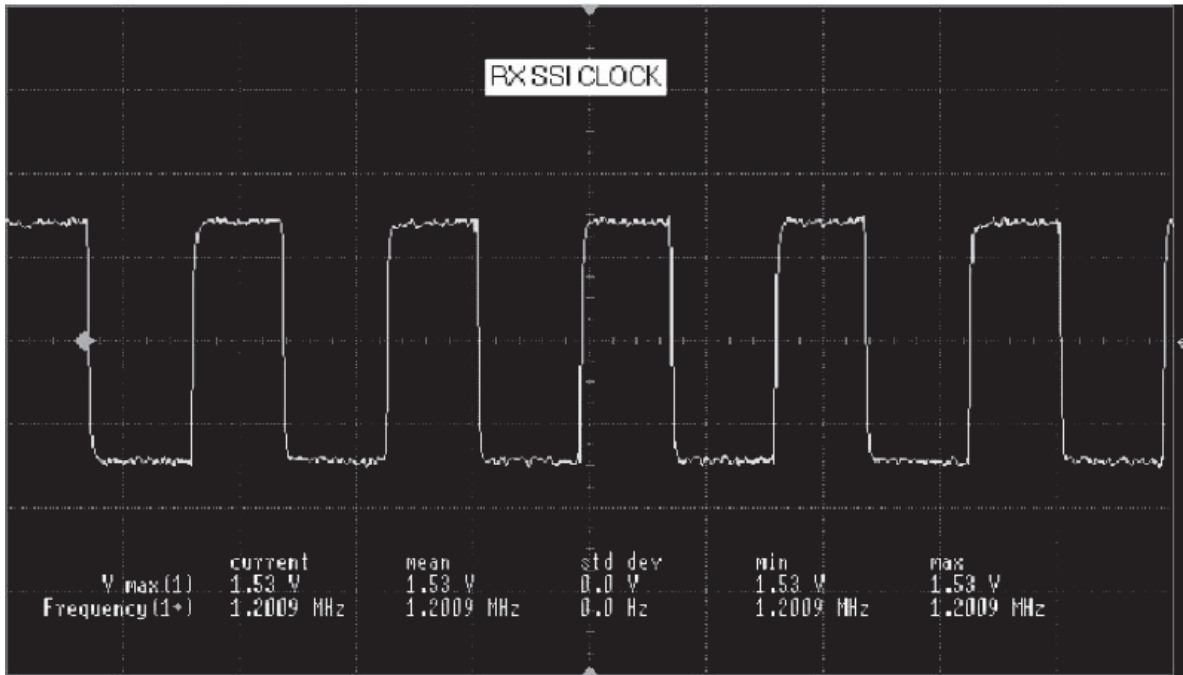

Test Point: TP404.

7.5.48 TP39 RX SSI Frame Sync

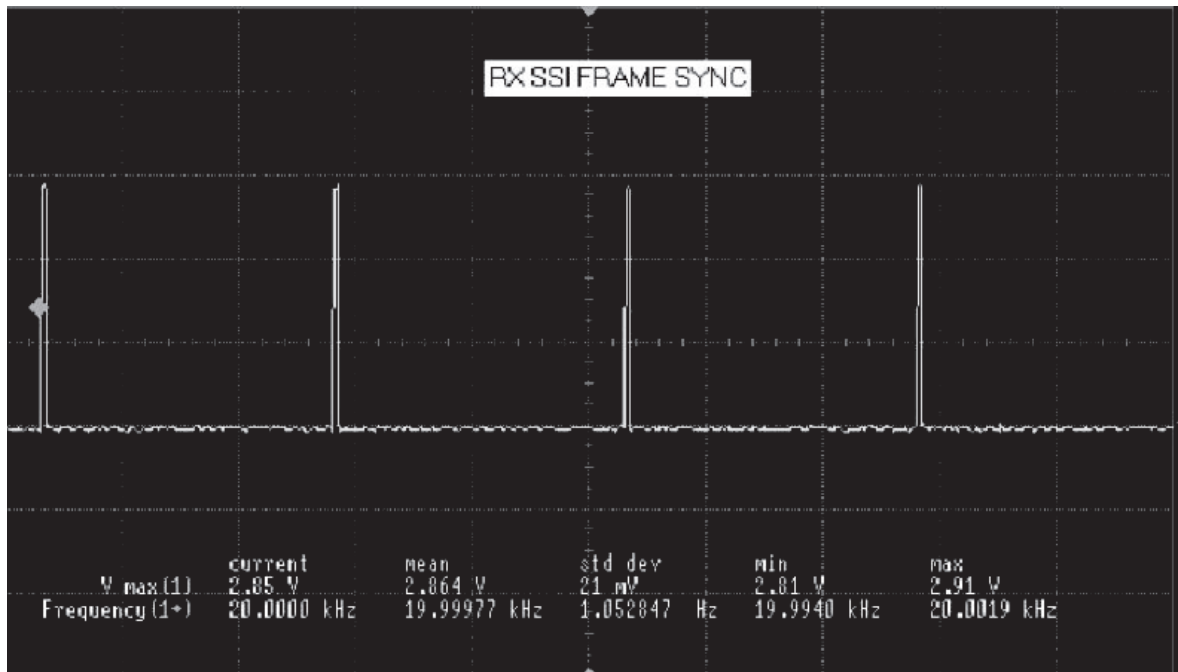

Test Point: TP402.

7.5.49 TP40 RX SSI Sync B

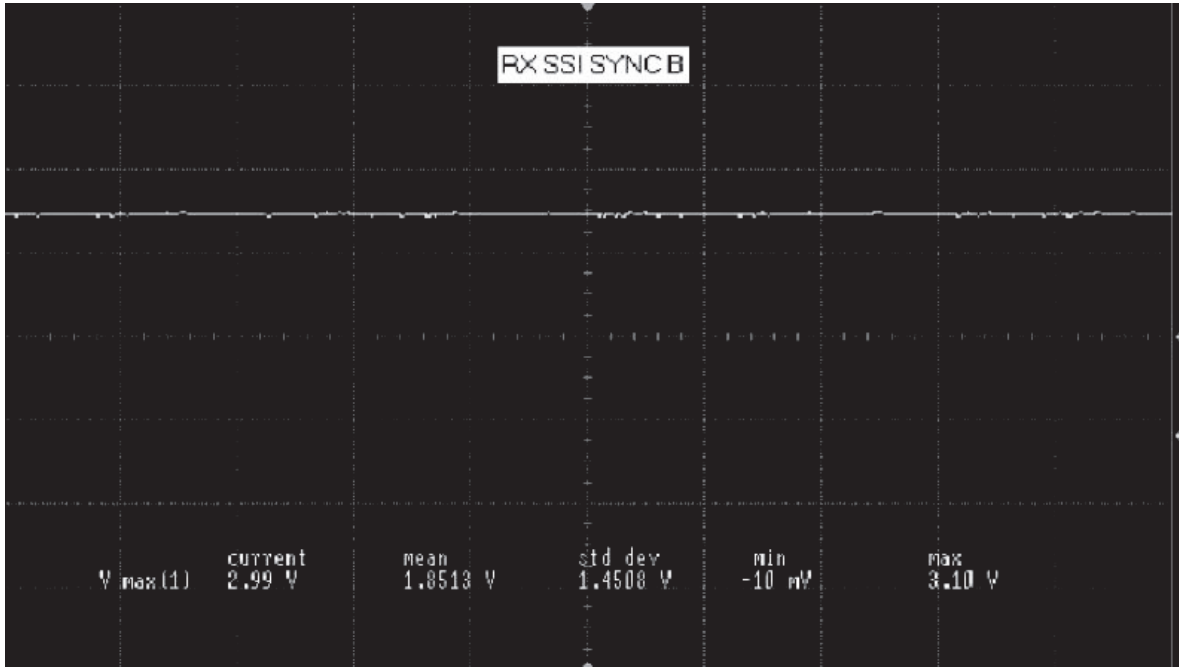

Test Point: TP401.

Chapter 8.1 VHF Troubleshooting Tables

8.1.1 Introduction

This chapter contains troubleshooting tables necessary to isolate a problem to the component level. Use these tables in conjunction with Chapter 4.1, VHF Detailed Theories of Operation (page 4.1-1), Chapter 5, Troubleshooting Procedures (page 5-1), Chapter 6.1, VHF Troubleshooting Charts (page 6.1-1), and Chapter 7.1, VHF Troubleshooting Waveforms (page 7.1-1). This manual is to be used in conjunction with the ASTRO XTS 2500/XTS 2500I Digital Portable Radios Basic Service Manual (Motorola part number 6816984H01), which uses the pass/fail service approach to radio problems.

A blank entry in the “To/From” column of J601 indicates the signal is accessible only at J601.

8.1.2 Tables

Table 8.1-1. Main Board to Keypad Board Flex Assembly (J601)

J601 Pin Number	Description	To/From
1	V1.875	L703
2	V2.9	L704
3	UNSW_B+	R701
4	SW_B+	R708
5	HOST_WAKE	
6	WAKEUP	
7	REGISTER_SEL	
8	DISPLAY_SEL	
9	SCKB	R620
10	SPI_MOSI_B	R621
11	SPI_MISO_B	R622
12	SSI_CLK	R616
13	SSI_FSYNC	R617
14	CODEC_TX	R625
15	CODEC_RX	R626
16	KEYPAD_ROW0	
17	KEYPAD_ROW1	
18	KEYPAD_ROW2	

Table 8.1-1. Main Board to Keypad Board Flex Assembly (J601) (Continued)

J601 Pin Number	Description	To/From
19	KEYPAD_ROW3	
20	KEYPAD_ROW4	
21	KEYPAD_ROW5	
22	KEYPAD_ROW6	
23	KEYPAD_COL0	
24	KEYPAD_COL1	
25	KEYPAD_COL2	
26	DO	R637
27	D1	R638
28	D2	R639
29	D3	R640
30	D4	R641
31	D5	R642
32	D6	R643
33	D7	R644
34	KEYFAIL	
35	CKIH	C726
36	BOOT*	C726
37	TEST_TAMPER	
38	DISPLAY_RESET	R647
39	UCM_SPARE1	
40	ENC_RXD (BT_RX)	
41	ENC_TXD (BT_TX)	
42	ENC_RESET	
43	BL_EN	
44	UCM_SPARE2	
45	GROUND	
46	GROUND	
47	GROUND	

Table 8.1-2. Main Board to Universal (Side) Connector Flex Assembly (J650)

J650 Pin Number	Description	To/From	Side Connector Number
1	GND	GND (TP)	8
2	INT_SPKR+	C654	
3	INT_SPKR-	C653	
4	OPT_SEL1	R608	1
5	EXT_SPKR+	EXTSP+ (TP)	2
6	EXT_MIC	EXTMIC (TP)	3
7	OPT_B+_VPP	VPP (TP)	4
8	OPT_SEL2	R666	5
9	SPKR_COM	EXT_SP (TP)	6
10	RTS_USB_PWR	RTS1 (TP)	7
11	GND	GND(TP)	8
12	LH_BUSY	BUSY (TP)	9
13	CTS	CTS1 (TP)	10
14	RS232_TX_USB+	USB_D+ (TP)	11
15	RS232_RX_USB-	USB_D- (TP)	12
16	LH_DATA_KEYFAIL	BUS (TP)	13
17	NOT USED		
18	INT_MIC	L652	
19	GND	GND (TP)	8
20	GND	GND(TP)	8

Table 8.1-3. FLASH (U803) Pinout

U803 Pin Number	Description	To/From	Comment	Accessible on Main Board?
B4	BURSTCLK			No
E7	CS0	TP_CS0	Active Low	Yes
F8	EN_OE			No
C5	EN_WE			No
D6	WRITE PROTECT			No
C4	ADV	ADV		Yes

Table 8.1-3. FLASH (U803) Pinout (Continued)

U803 Pin Number	Description	To/From	Comment	Accessible on Main Board?
B5	RESET	CR800, pin 2	1.875V	Yes
E8	ADDRESS 1			No
D8	ADDRESS 2			No
C8	ADDRESS 3			No
B8	ADDRESS 4			No
A8	ADDRESS 5			No
B7	ADDRESS 6			No
A7	ADDRESS 7			No
C7	ADDRESS 8			No
A2	ADDRESS 9			No
B2	ADDRESS 10			No
C2	ADDRESS 11			No
A1	ADDRESS 12			No
B1	ADDRESS 13			No
C1	ADDRESS 14			No
D2	ADDRESS 15			No
D1	ADDRESS 16			No
D4	ADDRESS 17			No
B6	ADDRESS 18			No
A6	ADDRESS 19			No
C6	ADDRESS 20			No
B3	ADDRESS 21			No
C3	ADDRESS 22			No
D7	ADDRESS 23	R814		Yes
A3	GROUND			No
F1	GROUND			No
G2	GROUND			No
G8	GROUND			No
E2	DATA 15			No
F2	DATA 14			No
F3	DATA 13			No

Table 8.1-3. FLASH (U803) Pinout (Continued)

U803 Pin Number	Description	To/From	Comment	Accessible on Main Board?
D5	DATA 12			No
F4	DATA 11			No
F5	DATA 10			No
F6	DATA 9			No
G7	DATA 8			No
G1	DATA 7			No
E3	DATA 6			No
G3	DATA 5			No
E4	DATA 4			No
G5	DATA 3			No
E5	DATA 2			No
E6	DATA 1			No
F7	DATA 0			No
A5	VPP	CR801, pin 2	1.875V	Yes
G6	V1.875	C850	1.875V	Yes
E1	V1.875	C850	1.875V	Yes
G4	V1.875	C850	1.875V	Yes
A4	V1.875	C850	1.875V	Yes

Table 8.1-4. SRAM (U804) Pinout

U804 Pin Number	Description	To/From	Comment	Accessible on Main Board?
A2	EN_OE			No
G5	R_W			Yes
A1	Byte Low Enable			No
B2	Byte High Enable			No
B5	CS2			No
A6	CE2			No
A3	ADDRESS 1			No
A4	ADDRESS 2			No
A5	ADDRESS 3			No
B3	ADDRESS 4			No
B4	ADDRESS 5			No
C3	ADDRESS 6			No
C4	ADDRESS 7			No
D4	ADDRESS 8			No
H2	ADDRESS 9			No
H3	ADDRESS 10			No
H4	ADDRESS 11			No
H5	ADDRESS 12			No
G3	ADDRESS 13			No
G4	ADDRESS 14			No
F3	ADDRESS 15			No
F4	ADDRESS 16			No
E4	ADDRESS 17			No
D3	ADDRESS 18			No
H1	ADDRESS 19			No
D1	GROUND			No
E6	GROUND			No
E3	GROUND			No
H6	NOT USED			No

Table 8.1-4. SRAM (U804) Pinout (Continued)

U804 Pin Number	Description	To/From	Comment	Accessible on Main Board?
G2	NOT USED			No
G1	DATA 15			No
F1	DATA 14			No
F2	DATA 13			No
E2	DATA 12			No
D2	DATA 11			No
C2	DATA 10			No
C1	DATA 9			No
B1	DATA 8			No
G6	DATA 7	R644		Yes
F6	DATA 6	R643		Yes
F5	DATA 5	R642		Yes
E5	DATA 4	R641		Yes
D5	DATA 3	R640		Yes
C6	DATA 2	R639		Yes
C5	DATA 1	R638		Yes
B6	DATA 0	R637		Yes
D6	VSW2	C818	1.875V	Yes
E1	VSW2	C818	1.875V	Yes

Table 8.1-5. Patriot MCU/DSP (U800) Pinout

U800 Pin Number	Description	To/From	Comment	Accessible on Main Board?
H10	NOT USED			Yes
J14	NOT USED			Yes
C14	NOT USED			Yes
B14	V2.9			No
F6	ONE-WIRE_UP			Yes
E5	32K_SEL	U712, pin 6	Active Low	Yes
J6	INT_PTT	R507	Active Low	Yes

Table 8.1-5. Patriot MCU/DSP (U800) Pinout (Continued)

U800 Pin Number	Description	To/From	Comment	Accessible on Main Board?
J5	MAKO_INT*	MAKO_INT (Test Point)		Yes
J4	OPT_SEL1	U201 pin 1		Yes
J3	NOT USED			No
C16	CODEC_FSYNC	SYNC	8 KHz Pulse	Yes
G11	OPT_SEL2_IN	U601 pin 1		Yes
F1	KEYPAD_ROW0	J601, pin 16		Yes
H4	KEYPAD_ROW1	J601, pin 17		Yes
H6	KEYPAD_ROW2	J601, pin 18		Yes
G2	KEYPAD_ROW3	J601, pin 19		Yes
G11	KEYPAD_ROW4	J601, pin 20		Yes
G7	KEYPAD_ROW5	J601, pin 21		Yes
H7	KEYPAD_ROW6	J601, pin22		Yes
H1	UCM_SPARE1	J601, pin 39		Yes
D1	KEYPAD_COL0	J601, pin 23		Yes
G5	KEYPAD_COL1	J601, pin 24		Yes
F3	KEYPAD_COL2	J601, pin 25		Yes
G4	ENC_RESET	J601, pin 42		Yes
F2	BOOT*			No
E1	WAKEUP	J601, pin 6		Yes
H6	SPARE2_ENC	J601, pin 44		Yes
G3	NOT USED			No
E7	NOT USED			No
A8	HAB_MOD			No
F8	MISOA_SEL	Q801, pin 1	Data Line	Yes
E8	SB3	R510		Yes
G8	SB2	R509		Yes
C3	SB1	R508		Yes
D4	LOCK_DET	C123	Active Low	Yes
A2	NOT USED			No
B2	RTA3	VR596, pin 2		Yes

Table 8.1-5. Patriot MCU/DSP (U800) Pinout (Continued)

U800 Pin Number	Description	To/From	Comment	Accessible on Main Board?
A3	RTA2	VR593, pin 2		Yes
B3	RTA1	VR595, pin 1		Yes
B4	RTA0	VR594, pin 2		Yes
A7	V1.875	E801	1.875V	Yes
P3	V1.875	E801	1.875V	Yes
P6	V1.875	E801	1.875V	Yes
T9	V1.875	E801	1.875V	Yes
N10	V1.875	E801	1.875V	Yes
R16	V1.875	E801	1.875V	Yes
H9	V2.9	E800	3.0V	Yes
G9	V2.9	E800	3.0V	Yes
E15	V2.9	E800	3.0V	Yes
A16	V2.9	E800	3.0V	Yes
K10	V2.9	E800	3.0V	Yes
C12	V2.9	E800	3.0V	Yes
D8	V2.9	E800	3.0V	Yes
B7	V2.9	E800	3.0V	Yes
A4	V2.9	E800	3.0V	Yes
A16	V2.9	E800	3.0V	Yes
H2	V2.9	E800	3.0V	Yes
K3	V1.875	E801	1.875V	Yes
R8	V1.875	E801	1.875V	Yes
G15	V1.875	E801	1.875V	Yes
C10	V1.875	E801	1.875V	Yes
K12	URXD1_USB_VMI			No
L16	URTS1_XRXD			No
F13	ADTRIG			No
B16	P-URXD2			No
D14	P-URTS2			No
B12	RX_SSI_DATA	SSI_D	Data From Abacus to DSP	Yes

Table 8.1-5. Patriot MCU/DSP (U800) Pinout (Continued)

U800 Pin Number	Description	To/From	Comment	Accessible on Main Board?
C11	TX_SSI_CLK	R259	1.536 MHz	Yes
B10	RED_LED	Q501, pin 3	Active High	Yes
D10	GREEN_LED	Q501, pin 5	Active High	Yes
B11	TX_SSI_FSYNC	R251	48 KHz	Yes
J10	CODEC_TX	TX	MAKO to DSP Tx Audio Data	Yes
J15	CODEC_DCLK	DCLK	512 KHz	Yes
K16	CODEC_FSYNC	SYNC	8 KHz Pulse	Yes
D7	MISOA	U801, pin 4	SPI A Data Out	Yes
D3	MISOB	BMISO	SPI B Data Out	Yes
E6	NOT USED			No
F7	NOT USED			No
D6	NOT USED			No
C5	NOT USED			No
A9	NOT USED			No
B8	NOT USED			No
B9	NOT USED			No
A10	NOT USED			No
G6	BT_DISABLE			No
D13	NOT USED			No
S15	BT_WAKE			No
F11	RX_SSI_CLK	SSI_CK		Yes
B15	OPT_SEL2_OUT	R666		Yes
J13	NOT USED			Yes
J16	NOT USED			Yes
J12	NOT USED			Yes
H11	NOT USED			Yes
A5	GROUND	GROUND		No
N6	GROUND	GROUND		No
P8	GROUND	GROUND		No

Table 8.1-5. Patriot MCU/DSP (U800) Pinout (Continued)

U800 Pin Number	Description	To/From	Comment	Accessible on Main Board?
P11	GROUND	GROUND		No
M11	GROUND	GROUND		No
L15	GROUND	GROUND		No
H16	GROUND	GROUND		No
F14	GROUND	GROUND		No
G14	GROUND	GROUND		No
E13	GROUND	GROUND		No
B13	GROUND	GROUND		No
K15	GROUND	GROUND		No
D9	GROUND	GROUND		No
C8	GROUND	GROUND		No
B5	GROUND	GROUND		No
C2	GROUND	GROUND		No
C1	GROUND	GROUND		No
H3	GROUND	GROUND		No
K15	GROUND	GROUND		No
T8	GROUND	GROUND		No
H15	GROUND	GROUND		No
C9	GROUND	GROUND		No
B6	ABACUS_CS*	U401, pin 25	Active Low	Yes
E2	UNIVERSAL_SPI_CS*	C222	Active Low	Yes
D2	NOT USED			No
E3	MAKO_CE		Active High	No
E4	SCKB	B_CLK	SPI B Clock	Yes
B1	NOT USED			No
F4	NOT USED			No
F5	SPI_MOSI_B	BMOSI	SPI B Data (VOCON)	Yes
C7	SPI_CLK_A	SCKA	SPI A Clock	Yes
C6	MOSIA	R802	SPI A Data (RF Devices)	Yes
G10	NOT USED			No

Table 8.1-5. Patriot MCU/DSP (U800) Pinout (Continued)

U800 Pin Number	Description	To/From	Comment	Accessible on Main Board?
G16	NOT USED			No
J11	CODEC_RX	R775	DSP to MAKO Rx Audio Data	Yes
A12	RX_SSI_FSYNC	SSI_FS	20 KHz pulse	Yes
A11	RX_SSI_CLK	SSI_CK	1.2 MHz	Yes
E9	TX_SSI_DATA	U201, pin 4	Data From DSP to A/D	Yes
C15	BSY_OUT_CTS*			No
F12	UTXD2			No
D15	NOT USED			No
E14	BOOT_NORM*			No
D16	RS232_USB*			No
G12	UCTS1_USB_SPEED*			No
K11	UTXD1_USB_VPO			No
K14	USB_VMO			No
K13	USB_TX_EN			No
D5	8 KHZ_INT	SYNC	8 KHz Pulse	R406
H14	BL_EN	J601, pin 43		Yes
K4	LV_DETECT	D511, pin 1	3.0V	Yes
F9	NOT USED			No
J2	SC_FILT_EN	FL200, pin 7		No
A6	16_8MHZ	C726	16.8 MHz	Yes
J7	GATED_32_KHZ	U712, pin 4	32.768 KHz	Yes
G13	NOT USED			No
J1	MOD	R634	Bootstrap mode > 2.7V	Yes
A13	NOT USED			No
M6	NOT USED			No
R1	NOT USED			No
N3	NOT USED			No
M5	NOT USED			No
P2	NOT USED			No

Table 8.1-5. Patriot MCU/DSP (U800) Pinout (Continued)

U800 Pin Number	Description	To/From	Comment	Accessible on Main Board?
P1	NOT USED			No
N1	NOT USED			No
M4	NOT USED			No
M3	NOT USED			No
M2	NOT USED			No
M1	NOT USED			No
L4	NOT USED			No
L3	NOT USED			No
L1	NOT USED			No
L2	NOT USED			No
K2	NOT USED			No
T1	NOT USED			No
R2	NOT USED			No
T2	NOT USED			No
K7	NOT USED			No
N2	NOT USED			No
L5	NOT USED			No
L6	NOT USED			No
C4	NOT USED			No
L13	NOT USED			No
D11	NOT USED			No
E16	KVL_USB_DET*		Active Low	No
F15	16.8_MHZ_OUT	16out (TP)		No
K5	NOT USED			Yes
H8	NOT USED			No
F16	RESET	R808	Reset = 0V	Yes
K6	USB_VPI			No
H12	BL_FREQ			No
H13	NOT USED			No
E10	NOT USED			No
F10	NOT USED			No

Table 8.1-5. Patriot MCU/DSP (U800) Pinout (Continued)

U800 Pin Number	Description	To/From	Comment	Accessible on Main Board?
D12	TCK	TCK	ONCE/JTAG	Yes
C13	TMS	TMS	ONCE/JTAG	Yes
E11	TRST	TRST	ONCE/JTAG	Yes
A14	TDO	TDO	ONCE/JTAG	Yes
E12	TDI	TDI	ONCE/JTAG	Yes
M16	NOT USED			No
L14	NOT USED			No
P15	NOT USED			No
L11	NOT USED			No
M14	NOT USED			No
N16	NOT USED			No
L12	NOT USED			No
M12	CKO	CKO	Disabled	Yes
N15	NOT USED			No
M15	NOT USED			No
R12	ADDRESS 0	J601, pin 7		Yes
T13	ADDRESS 1			No
M10	ADDRESS 2			No
T12	ADDRESS 3			No
P13	ADDRESS 4			No
M9	ADDRESS 5			No
P10	ADDRESS 6			No
P12	ADDRESS 7			No
N9	ADDRESS 8			No
R10	ADDRESS 9			No
P9	ADDRESS 10			No
L10	ADDRESS 11			No
T10	ADDRESS 12			No
R9	ADDRESS 13			No
L9	ADDRESS 14			No
K9	ADDRESS 15			No

Table 8.1-5. Patriot MCU/DSP (U800) Pinout (Continued)

U800 Pin Number	Description	To/From	Comment	Accessible on Main Board?
J9	ADDRESS 16			No
L8	ADDRESS 17			No
M8	ADDRESS 18			No
N8	ADDRESS 19			No
K8	ADDRESS 20			No
L7	ADDRESS 21			No
T7	ADDRESS 22			No
R7	ADDRESS 23	R814		Yes
R3	DATA 15			No
T3	DATA 14			No
N4	DATA 13			No
P4	DATA 12			No
R4	DATA 11			No
J8	DATA 10			No
T4	DATA 9			No
N5	DATA 8			No
P5	DATA 7	R644		Yes
R5	DATA 6	R643		Yes
T5	DATA 5	R642		Yes
R6	DATA 4	R641		Yes
T6	DATA 3	R640		Yes
M7	DATA 2	R639		Yes
N7	DATA 1	R638		Yes
P7	DATA 0	R637		Yes
N11	R_W			No
T11	NOT USED			No
R14	NOT USED			No
N12	CS3*			No
T14	CS2			No
R11	NOT USED			No
R15	CS0	TP_CS0	Active Low	Yes

Table 8.1-5. Patriot MCU/DSP (U800) Pinout (Continued)

U800 Pin Number	Description	To/From	Comment	Accessible on Main Board?
P16	OE_EN			No
M13	EB1_N			No
R13	EBO_N			No
N14	NOT USED			No
T16	WAIT			No
P14	NOT USED			No
N13	ADV			No
T15	B_CLK			No

Table 8.1-6. MAKO (U701) Pinout

Pin Ref Number	U701 Pin Name	To/From	Comment	Accessible on Main Board?
A4	VREF	GND	1.231	Yes
N3	UCM_SS	UCM_SS	2.9	No
P9	ONE_WIRE_1	ONE_WIRE_OPT	2.9	Yes
A5	BBP_CLK	TX_SSI_CLK	1.536MHz	Yes
H4	VCM2	GND	1/2 B+ (3.75V)	Yes
J1	EXT_MIC_M	GND	3.3V	Yes
J2	EXT_MIC_P	EXT_MIC	3.3V	Yes
J3	VCM1	GND	3.3V	Yes
K1	INT_MIC_M	GND	3.3V	Yes
K2	INT_MIC_P	INT_MIC	3.3V	Yes
B5	BBP_SYNC	TX_SSI_FSYNC	48KHz	Yes
E7	VC_DCLK	CODEC_DCLK	520Hz	Yes
L10	VMES	GND	5V	Yes
L11	ATOD_2	EMERG	5V	Yes
L2	MIC_BIAS	EXT_MIC	5V	Yes
L6	USB_CONNECT	Q704	5V	Yes
L8	ONE_WIRE_BATT	BAT_STATUS	5V	Yes
M10	TXDO_BDI_5V	RS232_DO_USB+	5V	Yes

Table 8.1-6. MAKO (U701) Pinout (Continued)

Pin Ref Number	U701 Pin Name	To/From	Comment	Accessible on Main Board?
M11	RTS_FILLSEN_5V	RTS	5V	Yes
M12	ADC_VREF	GND	5V	Yes
M13	ATOD_1	VOLUME	5V	Yes
N12	RXDIN_5V	RS232_DI_USB-	5V	Yes
N13	SB96_BUS_BUSY	SB9600_BUSY	5V	Yes
N6	USB1_DP	RS232_DI_USB-	5V	Yes
N9	SB96_BDO_KF_5V	LHDATA_KEYFAIL	5V	Yes
P13	CTS_CABLE_DET_5V	CTS	5V	Yes
P7	USB1_DM	RS232_DI_USB+	5V	Yes
D7	VC_FSYNC	CODEC_FSYNC	8KHz	Yes
F1	INT_SPKR_P	INT_SPKR_POS	B+(7.5V)	Yes
F2	INT_SPKR_M	INT_SPKR_NEG	B+(7.5V)	Yes
G1	EXT_SPKR_M	EXT_SPKR_NEG	B+(7.5V)	Yes
G2	PA_IN_P	VC_OUT_P	B+(7.5V)	Yes
G3	PA_IN_M	VC_OUT_N	B+(7.5V)	Yes
H1	EXT_SPKR_P	EXT_SPKR_POS	B+(7.5V)	Yes
H2	VC_OUT_M	PA_IN_N	B+(7.5V)	Yes
H3	VC_OUT_P	PA_IN_P	B+(7.5V)	Yes
A3	TEST	GND	GND	No
C4	SCAN_EN	GND	GND	No
E8	VFUSE	GND	GND	No
B11	AD_TRIG	ADTRIG	NA	No
B6	SPI_DI	SPI_MOSIB	NA	No
C6	SPI_DO	SPI_MISOB	NA	No
A11	TX_RX	NC	NC	No
B12	OPTION_INTX	NC	NC	No
B7	VC_TX	NC	NC	No
C10	USB_INTX	NC	NC	No
C11	OPT_GPIO1	NC	NC	No
D11	OPT_GPIO3	NC	NC	No

Table 8.1-6. MAKO (U701) Pinout (Continued)

Pin Ref Number	U701 Pin Name	To/From	Comment	Accessible on Main Board?
F10	OPT_GPIO0	NC	NC	No
G10	OPT_GPIO2	NC	NC	No
J5	TXDO_BDI_UP_3V	NC	NC	No
K12	ATOD_7	NC	NC	No
K13	ATOD_8	NC	NC	No
K6	TXDO_BDI_ENC_3V	NC	NC	No
K7	OPTA_SEL1	NC	NC	No
K8	OPTB_SEL1	NC	NC	No
L3	FE_TUNE1	NC	NC	No
M14	ATOD_3	NC	NC	No
M2	FE_TUNE2	NC	NC	No
M3	RTS_FILLSEN_3V	NC	NC	No
M8	ONE_WIRE_2	NC	NC	No
M9	OPTA_SEL2	NC	NC	No
N1	PWR_CTRL	NC	NC	No
N10	OPTA_SEL3	NC	NC	No
N11	OPTB_SEL3	NC	NC	No
N2	RXDIN_ENC_3V	NC	NC	No
N7	USB2_DP	NC	NC	No
N8	SB96D_BDO_KF_3V	NC	NC	No
P10	OPTA_SEL0	NC	NC	No
P11	OPTB_SEL0	NC	NC	No
P12	OPTB_SEL2	NC	NC	No
P2	RXDIN_3V	NC	NC	No
P8	USB2_DN	NC	NC	No
E1	PA_BPLUS	SW_B+	SW_B+(7.5V)	Yes
E3	BPLUS	BPLUS	UNSW_B+(7.5V)	No
A7	VC_RX	CODEC_RX	V1.55(1.6V)	Yes
A6	LOGIC_VDD	V2.9	V2.9	No
A8	RS232_USB_X	RS232_USB_X	V2.9	Yes

Table 8.1-6. MAKO (U701) Pinout (Continued)

Pin Ref Number	U701 Pin Name	To/From	Comment	Accessible on Main Board?
K11	ATOD_6	V2.9	V2.9	Yes
L13	ATOD_5	V2.9	V2.9	Yes
L5	APCO	V2.9	V2.9	Yes
M4	VC_TX3V	CODEC_TX	V2.9	Yes
N14	ATOD_0	V2.9	V2.9	No
L12	ATOD_4	BAT_STATUS	VCC5(5V)	Yes
A10	UART2_RXD_OD	SB96D_BDO_KF_3V/ V2.9/URXD3	VDD(1.65-3.6V)	Yes
A9	USB2_OE_RCV_RTS	URTS1_XRXD	VDD(1.65-3.6V)	Yes
B10	CTS_X	UCTS_USB_SPEED	VDD(1.65-3.6V)	Yes
B8	USB1_OE	USB_TXENAB	VDD(1.65-3.6V)	Yes
B9	USB2_DAT_VP	USB_VPI	VDD(1.65-3.6V)	Yes
C12	BUSY_IN	URTS2	VDD(1.65-3.6V)	Yes
C7	BOOT_NORM_X	BOOT_NORM_X	VDD(1.65-3.6V)	Yes
C8	USB1_DAT_TXD	TXD1_USB_VPO	VDD(1.65-3.6V)	Yes
C9	USB2_SE0_VM_RXD	URXD1_USB_VMI	VDD(1.65-3.6V)	Yes
D10	CABLE_DET_3V	KVL_USB_DET	VDD(1.65-3.6V)	Yes
D6	SPI_CS	MAKO_CE	VDD(1.65-3.6V)	Yes
D8	USB1_SE0	USB_VMO	VDD(1.65-3.6V)	Yes
E11	BUSY_OUT	UCTS2	VDD(1.65-3.6V)	Yes
E6	SPI_CLK	SCKB	VDD(1.65-3.6V)	Yes
E9	UART2_TXD	UTXD2	VDD(1.65-3.6V)	Yes
L7	ONE_WIRE_UP	ONE_WIRE_UP/V2.9	VDD(1.65-3.6V)	Yes
	POWER MANAGE- MENT BLOCK			
B2	BAT_TYPE	GND	0-5V	Yes
D2	BAT_3V6	GND	0-5V	Yes
D3	REG_3V6	GND	0-5V	Yes
G4	HV_BG	GND	1.2V	Yes
M1	TXCO_IN	16_8MHz	16.8MHz (2.5-3.3V)	Yes
J13	SW2_VOUT	GND	2.3V	Yes

Table 8.1-6. MAKO (U701) Pinout (Continued)

Pin Ref Number	U701 Pin Name	To/From	Comment	Accessible on Main Board?
J14	SW2_LX	GND	2.3V	Yes
A2	PGLD03	VSAVE	2.5V	Yes
C2	VSAVE	VSAVE	2.5V	Yes
E4	MECH_SW	SW_B+	2.5V	Yes
N5	V04_O	GND	2.775V	Yes
P6	V07_O	GND	2.8V	Yes
A12	XOUT	XTAL FREQ	24.576MHz (3.3V)	Yes
A13	XIN	XTAL FREQ	24.576MHz (3.3V)	Yes
L1	V09_O	GND	3.3V	Yes
M6	V10_O	GND	3.3V	Yes
B1	XTAL32_OUT	32.768KHz	32.768MHz (2.5-3.3V)	Yes
C1	XTAL32_IN	32.768KHz	32.768MHz (2.5-3.3V)	Yes
F5	GATED_32K_CLK	MAKO_32KHZ	32KHZ(VDD)	Yes
K4	V08_O	VCC5 SUPPLY	5V	Yes
E2	FET_ENX	VPP_EN/UNSW_B+/ SW_B+	B+(7.5V)	Yes
F14	SW1_PHASE	VSW1	B+(7.5V)	Yes
F3	BAT_RTC	GND	B+(7.5V)	Yes
B3	SW_TYPE	GND	GND	No
C3	PGLD02	GND	GND	No
D14	GND7	GND	GND	No
D4	TCXO_SEL_16_24	GND	GND	No
D9	GND9	GND	GND	No
G5	GND4	GND	GND	No
H14	SW1_GND	Q502	GND	No
H5	GND8	GND	GND	No
J4	GND3	GND	GND	No
K9	GND5	GND	GND	No
L14	SW2_GND	GND	GND	No
L4	GND6	GND	GND	No
L9	V10_GND	GND	GND	No

Table 8.1-6. MAKO (U701) Pinout (Continued)

Pin Ref Number	U701 Pin Name	To/From	Comment	Accessible on Main Board?
M7	GND2	GND	GND	No
P5	GND1	GND	GND	No
B13	VBUS_SUPPLY	NC	NC	No
B4	IGN_X	NC	NC	No
C13	VBUS2_CMD	NC	NC	No
C14	VBUS1_CMD	NC	NC	No
D12	VBUS2	NC	NC	No
D13	SW5_VDD	NC	NC	No
E12	VBUS1_SENS	NC	NC	No
E13	SW5_SUMCOMP	NC	NC	No
E14	SW5_VSENSE	NC	NC	No
F11	VBUS2_SENS	NC	NC	No
F12	SW5_VOUT	NC	NC	No
F13	SW5_VDDHV	NC	NC	No
F4	EMERG_PB	NC	NC	No
G11	SW5_PHASE	NC	NC	No
H10	VBUS1	NC	NC	No
H13	SW1_DH	NC	NC	No
J11	SW1_VSEN_BST	NC	NC	No
NC1	NC1	NC	NC	No
NC2	NC2	NC	NC	No
NC3	NC3	NC	NC	No
NC4	NC4	NC	NC	No
NC5	NC5	NC	NC	No
NC6	NC6	NC	NC	No
G12	SW1_VDDHV	SW_B+	SW_B+(7.5V)	Yes
H11	SW1_VSEN_BUK	SW_B+	SW_B+(7.5V)	Yes
K3	V08_I	SW_B+	SW_B+(7.5V)	Yes
D1	BAT_7V5	UNSW_B+	UNSW_B+(7.5V)	Yes
P4	V03_O	V1.55	V1.55(1.6V)	Yes

Table 8.1-6. MAKO (U701) Pinout (Continued)

Pin Ref Number	U701 Pin Name	To/From	Comment	Accessible on Main Board?
N4	V02_O	V1.875	V1.875	Yes
P3	V06_O	V2.9	V2.9	Yes
C5	RESETX	MAKO RESET	VDD(1.65-3.6V)	Yes
D5	INT_X	MAKO_INT_X	VDD(1.65-3.6V)	Yes
G13	SW1_VDD	Q702	VDD(1.65-3.6V)	Yes
G14	SW1_SUMCOMP_DL	Q702	VSW1 (3.6V)	Yes
H12	SW1_VOUT	VSW1	VSW1 (3.6V)	No
J10	V10_I	VSW1	VSW1 (3.6V)	Yes
J12	SW2_VCC	VSW1	VSW1 (3.6V)	Yes
K14	SW2_VCCS	VSW1	VSW1 (3.6V)	Yes

Chapter 8.2 UHF1 Troubleshooting Tables

8.2.1 Introduction

This chapter contains troubleshooting tables necessary to isolate a problem to the component level. Use these tables in conjunction with Chapter 4.2, UHF1 Detailed Theories of Operation (page 4.2-1), Chapter 5, Troubleshooting Procedures (page 5-1), Chapter 6.2, UHF1 Troubleshooting Charts (page 6.2-1), and Chapter 7.2, UHF1 Troubleshooting Waveforms (page 7.2-1). This manual is to be used in conjunction with the ASTRO XTS 2500/XTS 2500I Digital Portable Radios Basic Service Manual (Motorola part number 6816984H01), which uses the pass/fail service approach to radio problems.

A blank entry in the “To/From” column of J601 indicates the signal is accessible only at J601.

8.2.2 Tables

Table 8.2-1. Main Board to Keypad Board Flex Assembly (J601)

J601 Pin Number	Description	To/From
1	V1.875	L703
2	V2.9	L704
3	UNSW_B+	R701
4	SW_B+	R708
5	HOST_WAKE	
6	WAKEUP	
7	REGISTER_SEL	
8	DISPLAY_SEL	
9	SCKB	R620
10	SPI_MOSI_B	R621
11	SPI_MISO_B	R622
12	SSI_CLK	R616
13	SSI_FSYNC	R617
14	CODEC_TX	R625
15	CODEC_RX	R626
16	KEYPAD_ROW0	
17	KEYPAD_ROW1	
18	KEYPAD_ROW2	

Table 8.2-1. Main Board to Keypad Board Flex Assembly (J601) (Continued)

J601 Pin Number	Description	To/From
19	KEYPAD_ROW3	
20	KEYPAD_ROW4	
21	KEYPAD_ROW5	
22	KEYPAD_ROW6	
23	KEYPAD_COL0	
24	KEYPAD_COL1	
25	KEYPAD_COL2	
26	DO	R637
27	D1	R638
28	D2	R639
29	D3	R640
30	D4	R641
31	D5	R642
32	D6	R643
33	D7	R644
34	KEYFAIL	
35	CKIH	C726
36	BOOT*	C726
37	TEST_TAMPER	
38	DISPLAY_RESET	R647
39	UCM_SPARE1	
40	ENC_RXD (BT_RX)	
41	ENC_TXD (BT_TX)	
42	ENC_RESET	
43	BL_EN	
44	UCM_SPARE2	
45	GROUND	
46	GROUND	
47	GROUND	

Table 8.2-2. Main Board to Universal (Side) Connector Flex Assembly (J650)

J650 Pin Number	Description	To/From	Side Connector Number
1	GND	GND (TP)	8
2	INT_SPKR+	C654	
3	INT_SPKR-	C653	
4	OPT_SEL1	R608	1
5	EXT_SPKR+	EXTSP+ (TP)	2
6	EXT_MIC	EXTMIC (TP)	3
7	OPT_B+_VPP	VPP (TP)	4
8	OPT_SEL2	R666	5
9	SPKR_COM	EXT_SP (TP)	6
10	RTS_USB_PWR	RTS1 (TP)	7
11	GND	GND(TP)	8
12	LH_BUSY	BUSY (TP)	9
13	CTS	CTS1 (TP)	10
14	RS232_TX_USB+	USB_D+ (TP)	11
15	RS232_RX_USB-	USB_D (TP)	12
16	LH_DATA_KEYFAIL	BUS (TP)	13
17	NOT USED		
18	INT_MIC	L652	
19	GND	GND (TP)	8
20	GND	GND(TP)	8

Table 8.2-3. FLASH (U803) Pinout

U402 Pin Number	Description	To/From	Comment	Accessible on Main Board?
B4	BURSTCLK			No
E7	CS0	TP_CS0	Active Low	Yes
F8	EN_OE			No
C5	EN_WE			No
D6	WRITE PROTECT			No
C4	ADV	ADV		Yes

Table 8.2-3. FLASH (U803) Pinout (Continued)

U402 Pin Number	Description	To/From	Comment	Accessible on Main Board?
B5	RESET	CR800, pin 2	1.875V	Yes
E8	ADDRESS 0			No
D8	ADDRESS 1			No
C8	ADDRESS 2			No
B8	ADDRESS 3			No
A8	ADDRESS 4			No
B7	ADDRESS 5			No
A7	ADDRESS 6			No
C7	ADDRESS 7			No
A2	ADDRESS 8			No
B2	ADDRESS 9			No
C2	ADDRESS 10			No
A1	ADDRESS 11			No
B1	ADDRESS 12			No
C1	ADDRESS 13			No
D2	ADDRESS 14			No
D1	ADDRESS 15			No
D4	ADDRESS 16			No
B6	ADDRESS 17			No
A6	ADDRESS 18			No
C6	ADDRESS 19			No
B3	ADDRESS 20			No
C3	ADDRESS 21			No
D7	ADDRESS 22	R814		Yes
A3	GROUND			No
F1	GROUND			No
G2	GROUND			No
G8	GROUND			No
E2	DATA 15			No
F2	DATA 14			No
F3	DATA 13			No

Table 8.2-3. FLASH (U803) Pinout (Continued)

U402 Pin Number	Description	To/From	Comment	Accessible on Main Board?
D5	DATA 12			No
F4	DATA 11			No
F5	DATA 10			No
F6	DATA 9			No
G7	DATA 8			No
G1	DATA 7			No
E3	DATA 6			No
G3	DATA 5			No
E4	DATA 4			No
G5	DATA 3			No
E5	DATA 2			No
E6	DATA 1			No
F7	DATA 0			No
A5	VPP	CR801, pin 2	1.875V	Yes
G6	V1.875	C850	1.875V	Yes
E1	V1.875	C850	1.875V	Yes
G4	V1.875	C850	1.875V	Yes
A4	V1.875	C850	1.875V	Yes

Table 8.2-4. SRAM (U804) Pinout

U403 Pin Number	Description	To/From	Comment	Accessible on Main Board?
A2	EN_OE			No
G5	EN_WE			Yes
A1	Byte Low Enable			No
B2	Byte High Enable			No
B5	CS2			No
A6	CE2			No
A3	ADDRESS 0			No
A4	ADDRESS 1			No
A5	ADDRESS 2			No
B3	ADDRESS 3			No
B4	ADDRESS 4			No
C3	ADDRESS 5			No
C4	ADDRESS 6			No
D4	ADDRESS 7			No
H2	ADDRESS 8			No
H3	ADDRESS 9			No
H4	ADDRESS 10			No
H5	ADDRESS 11			No
G3	ADDRESS 12			No
G4	ADDRESS 13			No
F3	ADDRESS 14			No
F4	ADDRESS 15			No
E4	ADDRESS 16			No
D3	ADDRESS 17			No
H1	ADDRESS 18			No
D1	GROUND			No
E6	GROUND			No
E3	GROUND			No
H6	NOT USED			No

Table 8.2-4. SRAM (U804) Pinout (Continued)

U403 Pin Number	Description	To/From	Comment	Accessible on Main Board?
G2	NOT USED			No
G1	DATA 15			No
F1	DATA 14			No
F2	DATA 13			No
E2	DATA 12			No
D2	DATA 11			No
C2	DATA 10			No
C1	DATA 9			No
B1	DATA 8			No
G6	DATA 7	R644		Yes
F6	DATA 6	R643		Yes
F5	DATA 5	R642		Yes
E5	DATA 4	R641		Yes
D5	DATA 3	R640		Yes
C6	DATA 2	R639		Yes
C5	DATA 1	R638		Yes
B6	DATA 0	R637		Yes
D6	VSW2	C818	1.875V	Yes
E1	VSW2	C818	1.875V	Yes

Table 8.2-5. Patriot MCU/DSP (U800) Pinout

U401 Pin Number	Description	To/From	Comment	Accessible on Main Board?
H10	NOT USED			Yes
J14	NOT USED			Yes
C14	NOT USED			Yes
B14	V2.9			No
F6	ONE-WIRE_UP			Yes
E5	32K_SEL	U712, pin 6	Active Low	Yes
J6	INT_PTT	R507	Active Low	Yes

Table 8.2-5. Patriot MCU/DSP (U800) Pinout (Continued)

U401 Pin Number	Description	To/From	Comment	Accessible on Main Board?
J5	MAKO_INT*	MAKO_INT (Test Point)		Yes
J4	OPT_SEL1	U201 pin 1		Yes
J3	NOT USED			No
C16	CODEC_FSYNC	SYNC	8 KHz Pulse	Yes
G11	OPT_SEL2_IN	U601 pin 1		Yes
F1	KEYPAD_ROW0	J601, pin 16		Yes
H4	KEYPAD_ROW1	J601, pin 17		Yes
H6	KEYPAD_ROW2	J601, pin 18		Yes
G2	KEYPAD_ROW3	J601, pin 19		Yes
G1	KEYPAD_ROW4	J601, pin 20		Yes
G7	KEYPAD_ROW5	J601, pin 21		Yes
H7	KEYPAD_ROW6	J601, pin22		Yes
H1	UCM_SPARE1	J601, pin 39		Yes
D1	KEYPAD_COL0	J601, pin 23		Yes
G5	KEYPAD_COL1	J601, pin 24		Yes
F3	KEYPAD_COL2	J601, pin 25		Yes
G4	ENC_RESET	J601, pin 42		Yes
F2	BOOT*			No
E1	WAKEUP	J601, pin 6		Yes
H6	SPARE2_ENC	J601, pin 44		Yes
G3	NOT USED			No
E7	NOT USED			No
A8	HAB_MOD			No
F8	MISOA_SEL	Q801, pin 1	Data Line	Yes
E8	SB3	R510		Yes
G8	SB2	R509		Yes
C3	SB1	R508		Yes
D4	LOCK_DET		Active Low	Yes
A2	NOT USED			No
B2	RTA3	VR508, PIN 2		Yes

Table 8.2-5. Patriot MCU/DSP (U800) Pinout (Continued)

U401 Pin Number	Description	To/From	Comment	Accessible on Main Board?
A3	RTA2	VR509, PIN 2		Yes
B3	RTA1	VR510, PIN 2		Yes
B4	RTA0	VR511, PIN 2		Yes
A7	V1.875	E801	1.875V	Yes
P3	V1.875	E801	1.875V	Yes
P6	V1.875	E801	1.875V	Yes
T9	V1.875	E801	1.875V	Yes
N10	V1.875	E801	1.875V	Yes
R16	V1.875	E801	1.875V	Yes
A1	V2.9	E800	3.0V	Yes
G9	V2.9	E800	3.0V	Yes
E15	V2.9	E800	3.0V	Yes
A16	V2.9	E800	3.0V	Yes
K10	V2.9	E800	3.0V	Yes
C12	V2.9	E800	3.0V	Yes
D8	V2.9	E800	3.0V	Yes
B7	V2.9	E800	3.0V	Yes
A4	V2.9	E800	3.0V	Yes
A16	V2.9	E800	3.0V	Yes
H2	V2.9	E800	3.0V	Yes
K3	V1.875	E801	1.875V	Yes
R8	V1.875	E801	1.875V	Yes
G15	V1.875	E801	1.875V	Yes
C10	V1.875	E801	1.875V	Yes
K12	URXD1_USB_VMI			No
L16	URTS1_XRXD			No
F13	ADTRIG			No
B16	P-URXD2			No
D14	P-URTS2			No
B12	RX_SSI_DATA	TP403	Data From Abacus to DSP	Yes

Table 8.2-5. Patriot MCU/DSP (U800) Pinout (Continued)

U401 Pin Number	Description	To/From	Comment	Accessible on Main Board?
C11	TX_SSI_CLK	R259	1.536 MHz	Yes
B10	RED_LED	Q501, pin 3	Active High	Yes
D10	GREEN_LED	Q501, pin 5	Active High	Yes
B11	TX_SSI_FSYNC	R251	48 KHz	Yes
J10	CODEC_TX	TX	MAKO to DSP Tx Audio Data	Yes
J15	CODEC_DCLK	DCLK	512 KHz	Yes
K16	CODEC_FSYNC	SYNC	8 KHz Pulse	Yes
D7	MISOA	U801, pin 4	SPI A Data Out	Yes
D3	MISOB	BMISO	SPI B Data Out	Yes
E6	NOT USED			No
F7	NOT USED			No
D6	NOT USED			No
C5	NOT USED			No
A9	NOT USED			No
B8	NOT USED			No
B9	NOT USED			No
A10	NOT USED			No
G6	NOT USED			No
D13	NOT USED			No
S15	BT_WAKE			No
F11	RX_SSI_CLK	SSI_CK		Yes
B15	OPT_SEL2_OUT	R666		Yes
J13	NOT USED			Yes
J16	NOT USED			Yes
J12	NOT USED			Yes
H11	NOT USED			Yes
A5	GROUND	GROUND		No
N6	GROUND	GROUND		No
P8	GROUND	GROUND		No

Table 8.2-5. Patriot MCU/DSP (U800) Pinout (Continued)

U401 Pin Number	Description	To/From	Comment	Accessible on Main Board?
P11	GROUND	GROUND		No
M11	GROUND	GROUND		No
L15	GROUND	GROUND		No
H16	GROUND	GROUND		No
F14	GROUND	GROUND		No
G14	GROUND	GROUND		No
E13	GROUND	GROUND		No
B13	GROUND	GROUND		No
K15	GROUND	GROUND		No
D9	GROUND	GROUND		No
C8	GROUND	GROUND		No
B5	GROUND	GROUND		No
C2	GROUND	GROUND		No
C1	GROUND	GROUND		No
H3	GROUND	GROUND		No
K15	GROUND	GROUND		No
T8	GROUND	GROUND		No
H15	GROUND	GROUND		No
C9	GROUND	GROUND		No
B6	ABACUS_CS*	U401, pin 25	Active Low	Yes
E2	UNIVERSAL_SPI_CS*		Active Low	Yes
D2	NOT USED			No
E3	MAKO_CE		Active High	No
E4	SCKB	B_CLK	SPI B Clock	Yes
B1	NOT USED			No
F4	NOT USED			No
F5	SPI_MOSI_B	BMOSI	SPI B Data (VOCON)	Yes
C7	SPI_CLK_A	SCKA	SPI A Clock	Yes
C6	MOSIA	R802	SPI A Data (RF Devices)	Yes
G10	USM_SS			No

Table 8.2-5. Patriot MCU/DSP (U800) Pinout (Continued)

U401 Pin Number	Description	To/From	Comment	Accessible on Main Board?
G16	NOT USED			No
J11	CODEC_RX	R775	DSP to MAKO Rx Audio Data	Yes
A12	RX_SSI_FSYNC	SSI_FS	20 KHz pulse	Yes
A11	RX_SSI_CLK	SSI_CK	1.2 MHz	Yes
E9	TX_SSI_DATA		Data From DSP to A/D	Yes
C15	BSY_OUT_CTS*			No
F12	UTXD2			No
D15	NOT USED			No
E14	BOOT_NORM*			No
D16	RS232_USB*			No
G12	UCTS1_USB_SPEED*			No
K11	UTXD1_USB_VPO			No
K14	USB_VMO			No
K13	USB_TX_EN			No
D5	8 KHZ_INT	SYNC	8 KHz Pulse	R406
H14	BL_EN	J601, pin 43		Yes
K4	LV_DETECT	D511, pin 1	3.0V	Yes
F9	NOT USED			No
J2	SC_FILT_EN	FL200, pin 7		No
A6	16_8MHZ	C726	16.8 MHz	Yes
J7	GATED_32_KHZ	U712, pin 4	32.768 KHz	Yes
G13	NOT USED			No
J1	MOD	R634	Bootstrap mode > 2.7V	Yes
A13	NOT USED			No
M6	NOT USED			No
R1	NOT USED			No
N3	NOT USED			No
M5	NOT USED			No
P2	NOT USED			No

Table 8.2-5. Patriot MCU/DSP (U800) Pinout (Continued)

U401 Pin Number	Description	To/From	Comment	Accessible on Main Board?
P1	NOT USED			No
N1	NOT USED			No
M4	NOT USED			No
M3	NOT USED			No
M2	NOT USED			No
M1	NOT USED			No
L4	NOT USED			No
L3	NOT USED			No
L1	NOT USED			No
L2	NOT USED			No
K2	NOT USED			No
T1	NOT USED			No
R2	NOT USED			No
T2	NOT USED			No
K7	NOT USED			No
N2	NOT USED			No
L5	NOT USED			No
L6	NOT USED			No
C4	NOT USED			No
L13	NOT USED			No
D11	NOT USED			No
E16	KVL_USB_DET*		Active Low	No
F15	16.8_MHZ_OUT	16out (TP)		No
K5	NOT USED			Yes
H8	USB_ENUM			No
F16	RESET	R808	Reset = 0V	Yes
K6	USB_VPI			No
H12	BL_FREQ			No
H13	NOT USED			No
E10	DSP_DE			No
F10	MCU_DE			No

Table 8.2-5. Patriot MCU/DSP (U800) Pinout (Continued)

U401 Pin Number	Description	To/From	Comment	Accessible on Main Board?
D12	TCK	TCK	ONCE/JTAG	Yes
C13	TMS	TMS	ONCE/JTAG	Yes
E11	TRST	TRST	ONCE/JTAG	Yes
A14	TDO	TDO	ONCE/JTAG	Yes
E12	TDI	TDI	ONCE/JTAG	Yes
M16	NOT USED			No
L14	NOT USED			No
P15	NOT USED			No
L11	NOT USED			No
M14	NOT USED			No
N16	NOT USED			No
L12	NOT USED			No
M12	CKO	CKO	Disabled	Yes
N15	NOT USED			No
M15	NOT USED			No
R12	ADDRESS 0	J601, pin 7		Yes
T13	ADDRESS 1			No
M10	ADDRESS 2			No
T12	ADDRESS 3			No
P13	ADDRESS 4			No
M9	ADDRESS 5			No
P10	ADDRESS 6			No
P12	ADDRESS 7			No
N9	ADDRESS 8			No
R10	ADDRESS 9			No
P9	ADDRESS 10			No
L10	ADDRESS 11			No
T10	ADDRESS 12			No
R9	ADDRESS 13			No
L9	ADDRESS 14			No
K9	ADDRESS 15			No

Table 8.2-5. Patriot MCU/DSP (U800) Pinout (Continued)

U401 Pin Number	Description	To/From	Comment	Accessible on Main Board?
J9	ADDRESS 16			No
L8	ADDRESS 17			No
M8	ADDRESS 18			No
N8	ADDRESS 19			No
K8	ADDRESS 20			No
L7	ADDRESS 21			No
T7	ADDRESS 22			No
R7	ADDRESS 23	R814		Yes
R3	DATA 15			No
T3	DATA 14			No
N4	DATA 13			No
P4	DATA 12			No
R4	DATA 11			No
J8	DATA 10			No
T4	DATA 9			No
N5	DATA 8			No
P5	DATA 7	R644		Yes
R5	DATA 6	R643		Yes
T5	DATA 5	R642		Yes
R6	DATA 4	R641		Yes
T6	DATA 3	R640		Yes
M7	DATA 2	R639		Yes
N7	DATA 1	R638		Yes
P7	DATA 0	R637		Yes
N11	R_W			No
T11	NOT USED			No
R14	NOT USED			No
N12	CS3*			No
T14	CS2			No
R11	NOT USED			No
R15	CS0	TP_CS0	Active Low	Yes

Table 8.2-5. Patriot MCU/DSP (U800) Pinout (Continued)

U401 Pin Number	Description	To/From	Comment	Accessible on Main Board?
P16	OE_EN			No
M13	EB1_N			No
R13	EBO_N			No
N14	NOT USED			No
T16	WAIT			No
P14	NOT USED			No
N13	ADV			No
T15	B_CLK			No

Table 8.2-6. MAKO (U701) Pinout

Pin Ref Number	U701 Pin Name	To/From	Comment	Accessible on Main Board?
A4	VREF	GND	1.231	Yes
N3	UCM_SS	UCM_SS	2.9	No
P9	ONE_WIRE_1	ONE_WIRE_OPT	2.9	Yes
A5	BBP_CLK	TX_SSI_CLK	1.536MHz	Yes
H4	VCM2	GND	1/2 B+ (3.75V)	Yes
J1	EXT_MIC_M	GND	3.3V	Yes
J2	EXT_MIC_P	EXT_MIC	3.3V	Yes
J3	VCM1	GND	3.3V	Yes
K1	INT_MIC_M	GND	3.3V	Yes
K2	INT_MIC_P	INT_MIC	3.3V	Yes
B5	BBP_SYNC	TX_SSI_FSYNC	48KHz	Yes
E7	VC_DCLK	CODEC_DCLK	520Hz	Yes
L10	VMES	GND	5V	Yes
L11	ATOD_2	EMERG	5V	Yes
L2	MIC_BIAS	EXT_MIC	5V	Yes
L6	USB_CONNECT	Q704	5V	Yes
L8	ONE_WIRE_BATT	BAT_STATUS	5V	Yes
M10	TXDO_BDI_5V	RS232_DO_USB+	5V	Yes

Table 8.2-6. MAKO (U701) Pinout (Continued)

Pin Ref Number	U701 Pin Name	To/From	Comment	Accessible on Main Board?
M11	RTS_FILLSEN_5V	RTS	5V	Yes
M12	ADC_VREF	GND	5V	Yes
M13	ATOD_1	VOLUME	5V	Yes
N12	RXDIN_5V	RS232_DI_USB-	5V	Yes
N13	SB96_BUS_BUSY	SB9600_BUSY	5V	Yes
N6	USB1_DP	RS232_D0_USB+	5V	Yes
N9	SB96_BDO_KF_5V	LHDATA_KEYFAIL	5V	Yes
P13	CTS_CABLE_DET_5V	CTS	5V	Yes
P7	USB1_DM	RS232_DI_USB-	5V	Yes
D7	VC_FSYNC	CODEC_FSYNC	8KHz	Yes
F1	INT_SPKR_P	INT_SPKR_POS	B+(7.5V)	Yes
F2	INT_SPKR_M	INT_SPKR_NEG	B+(7.5V)	Yes
G1	EXT_SPKR_M	EXT_SPKR_NEG	B+(7.5V)	Yes
G2	PA_IN_P	VC_OUT_P	B+(7.5V)	Yes
G3	PA_IN_M	VC_OUT_M	B+(7.5V)	Yes
H1	EXT_SPKR_P	EXT_SPKR_POS	B+(7.5V)	Yes
H2	VC_OUT_M	PA_IN_N	B+(7.5V)	Yes
H3	VC_OUT_P	PA_IN_P	B+(7.5V)	Yes
A3	TEST	GND	GND	No
C4	SCAN_EN	GND	GND	No
E8	VFUSE	GND	GND	No
B11	AD_TRIG	ADTRIG	NA	No
B6	SPI_DI	SPI_MOSIB	NA	No
C6	SPI_DO	SPI_MISOB	NA	No
A11	TX_RX	NC	NC	No
B12	OPTION_INTX	NC	NC	No
B7	VC_TX	NC	NC	No
C10	USB_INTX	NC	NC	No
C11	OPT_GPIO1	NC	NC	No
D11	OPT_GPIO3	NC	NC	No

Table 8.2-6. MAKO (U701) Pinout (Continued)

Pin Ref Number	U701 Pin Name	To/From	Comment	Accessible on Main Board?
F10	OPT_GPIO0	NC	NC	No
G10	OPT_GPIO2	NC	NC	No
J5	TXDO_BDI_UP_3V	TXDO_BDI_ENC_3V	NC	No
K12	ATOD_7	NC	NC	No
K13	ATOD_8	NC	NC	No
K6	TXDO_BDI_ENC_3V	TXDO_BDI_UP_3V	NC	No
K7	OPTA_SEL1	NC	NC	No
K8	OPTB_SEL1	NC	NC	No
L3	FE_TUNE1	NC	NC	No
M14	ATOD_3	NC	NC	No
M2	FE_TUNE2	NC	NC	No
M3	RTS_FILLSEN_3V	NC	NC	No
M8	ONE_WIRE_2	NC	NC	No
M9	OPTA_SEL2	NC	NC	No
N1	PWR_CTRL	NC	NC	No
N10	OPTA_SEL3	NC	NC	No
N11	OPTB_SEL3	NC	NC	No
N2	RXDIN_ENC_3V	RXDIN_3V	NC	No
N7	USB2_DP	NC	NC	No
N8	SB96D_BDO_KF_3V	UART2_RXD_OD	NC	No
P10	OPTA_SEL0	NC	NC	No
P11	OPTB_SEL0	NC	NC	No
P12	OPTB_SEL2	NC	NC	No
P2	RXDIN_3V	RXDIN_ENC_3V	NC	No
P8	USB2_DM	NC	NC	No
E1	PA_BPLUS	SW_B+	SW_B+(7.5V)	Yes
E3	BPLUS	BPLUS	UNSW_B+(7.5V)	No
A7	VC_RX	CODEC_RX	V1.55(1.6V)	Yes
A6	LOGIC_VDD	V2.9	V2.9	No
A8	RS232_USB_X	RS232_USB_X	V2.9	Yes

Table 8.2-6. MAKO (U701) Pinout (Continued)

Pin Ref Number	U701 Pin Name	To/From	Comment	Accessible on Main Board?
K11	ATOD_6	V2.9	V2.9	Yes
L13	ATOD_5	V2.9	V2.9	Yes
L5	APCO	V2.9	V2.9	Yes
M4	VC_TX3V	CODEC_TX	V2.9	Yes
N14	ATOD_0	V2.9	V2.9	No
L12	ATOD_4	BAT_STATUS	VCC5(5V)	Yes
A10	UART2_RXD_OD	SB96D_BDO_KF_3V/ V2.9/URXD3	VDD(1.65-3.6V)	Yes
A9	USB2_OE_RCV_RTS	URTS1_XRXD	VDD(1.65-3.6V)	Yes
B10	CTS_X	UCTS_USB_SPEED	VDD(1.65-3.6V)	Yes
B8	USB1_OE	USB_TXENAB	VDD(1.65-3.6V)	Yes
B9	USB2_DAT_VP	USB_VPI	VDD(1.65-3.6V)	Yes
C12	BUSY_IN	BUSY_IN_RTS	VDD(1.65-3.6V)	Yes
C7	BOOT_NORM_X	BOOT_NORM_X	VDD(1.65-3.6V)	Yes
C8	USB1_DAT_TXD	TXD1_USB_VPO	VDD(1.65-3.6V)	Yes
C9	USB2_SE0_VM_RXD	URXD1_USB_VMI	VDD(1.65-3.6V)	Yes
D10	CABLE_DET_3V	KVL_USB_DET	VDD(1.65-3.6V)	Yes
D6	SPI_CS	MAKO_CE	VDD(1.65-3.6V)	Yes
D8	USB1_SE0	USB_VMO	VDD(1.65-3.6V)	Yes
E11	BUSY_OUT	BUSY_OUT_CTS	VDD(1.65-3.6V)	Yes
E6	SPI_CLK	SCKB	VDD(1.65-3.6V)	Yes
E9	UART2_TXD	UTXD2	VDD(1.65-3.6V)	Yes
L7	ONE_WIRE_UP	ONE_WIRE_UP/V2.9	VDD(1.65-3.6V)	Yes
	POWER MANAGE- MENT BLOCK			
B2	BAT_TYPE	GND	0-5V	Yes
D2	BAT_3V6	GND	0-5V	Yes
D3	REG_3V6	GND	0-5V	Yes
G4	HV_BG	GND	1.2V	Yes
M1	TXCO_IN	16_8MHz	16.8MHz (2.5-3.3V)	Yes
J13	SW2_VOUT	GND	2.3V	Yes

Table 8.2-6. MAKO (U701) Pinout (Continued)

Pin Ref Number	U701 Pin Name	To/From	Comment	Accessible on Main Board?
J14	SW2_LX	GND	2.3V	Yes
A2	PGLD03	VSAVE	2.5V	Yes
C2	VSAVE	VSAVE	2.5V	Yes
E4	MECH_SW	MECH_SW	2.5V	Yes
N5	V04_O	GND	2.775V	Yes
P6	V07_O	GND	2.8V	Yes
A12	XOUT	XTAL FREQ	24.576MHz (3.3V)	Yes
A13	XIN	XTAL FREQ	24.576MHz (3.3V)	Yes
L1	V09_O	GND	3.3V	Yes
M6	V10_O	GND	3.3V	Yes
B1	XTAL32_OUT	32.768KHz	32.768MHz (2.5-3.3V)	Yes
C1	XTAL32_IN	32.768KHz	32.768MHz (2.5-3.3V)	Yes
F5	GATED_32K_CLK	MAKO_32KHZ	32KHZ(VDD)	Yes
K4	V08_O	VCC5 SUPPLY	5V	Yes
E2	FET_ENX	VPP_EN/UNSW_B+/ SW_B+	B+(7.5V)	Yes
F14	SW1_PHASE	VSW1	B+(7.5V)	Yes
F3	BAT_RTC	GND	B+(7.5V)	Yes
B3	SW_TYPE	GND	GND	No
C3	PGLD02	GND	GND	No
D14	GND7	GND	GND	No
D4	TCXO_SEL_16_24	GND	GND	No
D9	GND9	GND	GND	No
G5	GND4	GND	GND	No
H14	SW1_GND	Q702	GND	No
H5	GND8	GND	GND	No
J4	GND3	GND	GND	No
K9	GND5	GND	GND	No
L14	SW2_GND	GND	GND	No
L4	GND6	GND	GND	No
L9	V10_GND	GND	GND	No

Table 8.2-6. MAKO (U701) Pinout (Continued)

Pin Ref Number	U701 Pin Name	To/From	Comment	Accessible on Main Board?
M7	GND2	GND	GND	No
P5	GND1	GND	GND	No
B13	VBUS_SUPPLY	NC	NC	No
B4	IGN_X	NC	NC	No
C13	VBUS2_CMD	NC	NC	No
C14	VBUS1_CMD	NC	NC	No
D12	VBUS2	NC	NC	No
D13	SW5_VDD	NC	NC	No
E12	VBUS1_SENS	NC	NC	No
E13	SW5_SUMCOMP	NC	NC	No
E14	SW5_VSENSE	NC	NC	No
F11	VBUS2_SENS	NC	NC	No
F12	SW5_VOUT	NC	NC	No
F13	SW5_VDDHV	NC	NC	No
F4	EMERG_PB	NC	NC	No
G11	SW5_PHASE	NC	NC	No
H10	VBUS1	NC	NC	No
H13	SW1_DH	NC	NC	No
J11	SW1_VSEN_BST	NC	NC	No
NC1	NC1	NC	NC	No
NC2	NC2	NC	NC	No
NC3	NC3	NC	NC	No
NC4	NC4	NC	NC	No
NC5	NC5	NC	NC	No
NC6	NC6	NC	NC	No
G12	SW1_VDDHV	SW_B+	SW_B+(7.5V)	Yes
H11	SW1_VSEN_BUK	SW_B+	SW_B+(7.5V)	Yes
K3	V08_I	SW_B+	SW_B+(7.5V)	Yes
D1	BAT_7V5	UNSW_B+	UNSW_B+(7.5V)	Yes
P4	V03_O	V1.55	V1.55(1.6V)	Yes

Table 8.2-6. MAKO (U701) Pinout (Continued)

Pin Ref Number	U701 Pin Name	To/From	Comment	Accessible on Main Board?
N4	V02_O	V1.875	V1.875	Yes
P3	V06_O	V2.9	V2.9	Yes
C5	RESETX	MAKO RESET	VDD(1.65-3.6V)	Yes
D5	INT_X	MAKO_INT_X	VDD(1.65-3.6V)	Yes
G13	SW1_VDD	Q702	VDD(1.65-3.6V)	Yes
G14	SW1_SUMCOMP_DL	Q702	VSW1 (3.6V)	Yes
H12	SW1_VOUT	VSW1	VSW1 (3.6V)	No
J10	V10_I	VSW1	VSW1 (3.6V)	Yes
J12	SW2_VCC	VSW1	VSW1 (3.6V)	Yes
K14	SW2_VCCS	VSW1	VSW1 (3.6V)	Yes

Chapter 8.3 UHF2 Troubleshooting Tables

8.3.1 Introduction

This chapter contains troubleshooting tables necessary to isolate a problem to the component level. Use these tables in conjunction with Chapter 4.3, UHF2 Detailed Theories of Operation (page 4.3-1), Chapter 5, Troubleshooting Procedures (page 5-1), Chapter 6.3, UHF2 Troubleshooting Charts (page 6.3-1), and Chapter 7.3, UHF2 Troubleshooting Waveforms (page 7.3-1). This manual is to be used in conjunction with the ASTRO XTS 2500/XTS 2500I Digital Portable Radios Basic Service Manual (Motorola part number 6816984H01), which uses the pass/fail service approach to radio problems.

A blank entry in the “To/From” column of J601 indicates the signal is accessible only at J601.

8.3.2 Tables

Table 8.3-1. Main Board to Keypad Board Flex Assembly (J601)

J601 Pin Number	Description	To/From
1	V1.875	L703
2	V2.9	L704
3	UNSW_B+	R701
4	SW_B+	R708
5	HOST_WAKE	
6	WAKEUP	
7	REGISTER_SEL	
8	DISPLAY_SEL	
9	SCKB	R620
10	SPI_MOSI_B	R621
11	SPI_MISO_B	R622
12	SSI_CLK	R616
13	SSI_FSYNC	R617
14	CODEC_TX	R625
15	CODEC_RX	R626
16	KEYPAD_ROW0	
17	KEYPAD_ROW1	
18	KEYPAD_ROW2	

Table 8.3-1. Main Board to Keypad Board Flex Assembly (J601) (Continued)

J601 Pin Number	Description	To/From
19	KEYPAD_ROW3	
20	KEYPAD_ROW4	
21	KEYPAD_ROW5	
22	KEYPAD_ROW6	
23	KEYPAD_COL0	
24	KEYPAD_COL1	
25	KEYPAD_COL2	
26	DO	R637
27	D1	R638
28	D2	R639
29	D3	R640
30	D4	R641
31	D5	R642
32	D6	R643
33	D7	R644
34	KEYFAIL	
35	CKIH	C726
36	BOOT*	C726
37	TEST_TAMPER	
38	DISPLAY_RESET	R647
39	UCM_SPARE1	
40	ENC_RXD (BT_RX)	
41	ENC_TXD (BT_TX)	
42	ENC_RESET	
43	BL_EN	
44	UCM_SPARE2	
45	GROUND	
46	GROUND	
47	GROUND	

Table 8.3-2. Main Board to Universal (Side) Connector Flex Assembly (J650)

J650 Pin Number	Description	To/From	Side Connector Number
1	GND	GND (TP)	8
2	INT_SPKR+	C654	
3	INT_SPKR-	C653	
4	OPT_SEL1	R608	1
5	EXT_SPKR+	EXTSP+ (TP)	2
6	EXT_MIC	EXTMIC (TP)	3
7	OPT_B+_VPP	VPP (TP)	4
8	OPT_SEL2	R666	5
9	SPKR_COM	EXT_SP (TP)	6
10	RTS_USB_PWR	RTS1 (TP)	7
11	GND	GND(TP)	8
12	LH_BUSY	BUSY (TP)	9
13	CTS	CTS1 (TP)	10
14	RS232_TX_USB+	USB_D+ (TP)	11
15	RS232_RX_USB-	USB_D (TP)	12
16	LH_DATA_KEYFAIL	BUS (TP)	13
17	NOT USED		
18	INT_MIC	L652	
19	GND	GND (TP)	8
20	GND	GND(TP)	8

Table 8.3-3. FLASH (U803) Pinout

U402 Pin Number	Description	To/From	Comment	Accessible on Main Board?
B4	BURSTCLK			No
E7	CS0	TP_CS0	Active Low	Yes
F8	EN_OE			No
C5	EN_WE			No
D6	WRITE PROTECT			No
C4	ADV	ADV		Yes

Table 8.3-3. FLASH (U803) Pinout (Continued)

U402 Pin Number	Description	To/From	Comment	Accessible on Main Board?
B5	RESET	CR800, pin 2	1.875V	Yes
E8	ADDRESS 0			No
D8	ADDRESS 1			No
C8	ADDRESS 2			No
B8	ADDRESS 3			No
A8	ADDRESS 4			No
B7	ADDRESS 5			No
A7	ADDRESS 6			No
C7	ADDRESS 7			No
A2	ADDRESS 8			No
B2	ADDRESS 9			No
C2	ADDRESS 10			No
A1	ADDRESS 11			No
B1	ADDRESS 12			No
C1	ADDRESS 13			No
D2	ADDRESS 14			No
D1	ADDRESS 15			No
D4	ADDRESS 16			No
B6	ADDRESS 17			No
A6	ADDRESS 18			No
C6	ADDRESS 19			No
B3	ADDRESS 20			No
C3	ADDRESS 21			No
D7	ADDRESS 22	R814		Yes
A3	GROUND			No
F1	GROUND			No
G2	GROUND			No
G8	GROUND			No
E2	DATA 15			No
F2	DATA 14			No
F3	DATA 13			No

Table 8.3-3. FLASH (U803) Pinout (Continued)

U402 Pin Number	Description	To/From	Comment	Accessible on Main Board?
D5	DATA 12			No
F4	DATA 11			No
F5	DATA 10			No
F6	DATA 9			No
G7	DATA 8			No
G1	DATA 7			No
E3	DATA 6			No
G3	DATA 5			No
E4	DATA 4			No
G5	DATA 3			No
E5	DATA 2			No
E6	DATA 1			No
F7	DATA 0			No
A5	VPP	CR801, pin 2	1.875V	Yes
G6	V1.875	C850	1.875V	Yes
E1	V1.875	C850	1.875V	Yes
G4	V1.875	C850	1.875V	Yes
A4	V1.875	C850	1.875V	Yes

Table 8.3-4. SRAM (U804) Pinout

U403 Pin Number	Description	To/From	Comment	Accessible on Main Board?
A2	EN_OE			No
G5	EN_WE			Yes
A1	Byte Low Enable			No
B2	Byte High Enable			No
B5	CS2			No
A6	CE2			No
A3	ADDRESS 0			No
A4	ADDRESS 1			No
A5	ADDRESS 2			No
B3	ADDRESS 3			No
B4	ADDRESS 4			No
C3	ADDRESS 5			No
C4	ADDRESS 6			No
D4	ADDRESS 7			No
H2	ADDRESS 8			No
H3	ADDRESS 9			No
H4	ADDRESS 10			No
H5	ADDRESS 11			No
G3	ADDRESS 12			No
G4	ADDRESS 13			No
F3	ADDRESS 14			No
F4	ADDRESS 15			No
E4	ADDRESS 16			No
D3	ADDRESS 17			No
H1	ADDRESS 18			No
D1	GROUND			No
E6	GROUND			No
E3	GROUND			No
H6	NOT USED			No

Table 8.3-4. SRAM (U804) Pinout (Continued)

U403 Pin Number	Description	To/From	Comment	Accessible on Main Board?
G2	NOT USED			No
G1	DATA 15			No
F1	DATA 14			No
F2	DATA 13			No
E2	DATA 12			No
D2	DATA 11			No
C2	DATA 10			No
C1	DATA 9			No
B1	DATA 8			No
G6	DATA 7	R644		Yes
F6	DATA 6	R643		Yes
F5	DATA 5	R642		Yes
E5	DATA 4	R641		Yes
D5	DATA 3	R640		Yes
C6	DATA 2	R639		Yes
C5	DATA 1	R638		Yes
B6	DATA 0	R637		Yes
D6	VSW2	C818	1.875V	Yes
E1	VSW2	C818	1.875V	Yes

Table 8.3-5. Patriot MCU/DSP (U800) Pinout

U401 Pin Number	Description	To/From	Comment	Accessible on Main Board?
H10	NOT USED			Yes
J14	NOT USED			Yes
C14	NOT USED			Yes
B14	V2.9			No
F6	ONE-WIRE_UP			Yes
E5	32K_SEL	U712, pin 6	Active Low	Yes
J6	INT_PTT	R507	Active Low	Yes

Table 8.3-5. Patriot MCU/DSP (U800) Pinout (Continued)

U401 Pin Number	Description	To/From	Comment	Accessible on Main Board?
J5	MAKO_INT*	MAKO_INT (Test Point)		Yes
J4	OPT_SEL1	U201 pin 1		Yes
J3	NOT USED			No
C16	CODEC_FSYNC	SYNC	8 KHz Pulse	Yes
G11	OPT_SEL2_IN	U601 pin 1		Yes
F1	KEYPAD_ROW0	J601, pin 16		Yes
H4	KEYPAD_ROW1	J601, pin 17		Yes
H6	KEYPAD_ROW2	J601, pin 18		Yes
G2	KEYPAD_ROW3	J601, pin 19		Yes
G1	KEYPAD_ROW4	J601, pin 20		Yes
G7	KEYPAD_ROW5	J601, pin 21		Yes
H7	KEYPAD_ROW6	J601, pin22		Yes
H1	UCM_SPARE1	J601, pin 39		Yes
D1	KEYPAD_COL0	J601, pin 23		Yes
G5	KEYPAD_COL1	J601, pin 24		Yes
F3	KEYPAD_COL2	J601, pin 25		Yes
G4	ENC_RESET	J601, pin 42		Yes
F2	BOOT*			No
E1	WAKEUP	J601, pin 6		Yes
H6	SPARE2_ENC	J601, pin 44		Yes
G3	NOT USED			No
E7	NOT USED			No
A8	HAB_MOD			No
F8	MISOA_SEL	Q801, pin 1	Data Line	Yes
E8	SB3	R510		Yes
G8	SB2	R509		Yes
C3	SB1	R508		Yes
D4	LOCK_DET		Active Low	Yes
A2	NOT USED			No
B2	RTA3	VR508, PIN 2		Yes

Table 8.3-5. Patriot MCU/DSP (U800) Pinout (Continued)

U401 Pin Number	Description	To/From	Comment	Accessible on Main Board?
A3	RTA2	VR509, PIN 2		Yes
B3	RTA1	VR510, PIN 2		Yes
B4	RTA0	VR511, PIN 2		Yes
A7	V1.875	E801	1.875V	Yes
P3	V1.875	E801	1.875V	Yes
P6	V1.875	E801	1.875V	Yes
T9	V1.875	E801	1.875V	Yes
N10	V1.875	E801	1.875V	Yes
R16	V1.875	E801	1.875V	Yes
A1	V2.9	E800	3.0V	Yes
G9	V2.9	E800	3.0V	Yes
E15	V2.9	E800	3.0V	Yes
A16	V2.9	E800	3.0V	Yes
K10	V2.9	E800	3.0V	Yes
C12	V2.9	E800	3.0V	Yes
D8	V2.9	E800	3.0V	Yes
B7	V2.9	E800	3.0V	Yes
A4	V2.9	E800	3.0V	Yes
A16	V2.9	E800	3.0V	Yes
H2	V2.9	E800	3.0V	Yes
K3	V1.875	E801	1.875V	Yes
R8	V1.875	E801	1.875V	Yes
G15	V1.875	E801	1.875V	Yes
C10	V1.875	E801	1.875V	Yes
K12	URXD1_USB_VMI			No
L16	URTS1_XRXD			No
F13	ADTRIG			No
B16	P-URXD2			No
D14	P-URTS2			No
B12	RX_SSI_DATA	TP403	Data From Abacus to DSP	Yes

Table 8.3-5. Patriot MCU/DSP (U800) Pinout (Continued)

U401 Pin Number	Description	To/From	Comment	Accessible on Main Board?
C11	TX_SSI_CLK	R259	1.536 MHz	Yes
B10	RED_LED	Q501, pin 3	Active High	Yes
D10	GREEN_LED	Q501, pin 5	Active High	Yes
B11	TX_SSI_FSYNC	R251	48 KHz	Yes
J10	CODEC_TX	TX	MAKO to DSP Tx Audio Data	Yes
J15	CODEC_DCLK	DCLK	512 KHz	Yes
K16	CODEC_FSYNC	SYNC	8 KHz Pulse	Yes
D7	MISOA	U801, pin 4	SPI A Data Out	Yes
D3	MISOB	BMISO	SPI B Data Out	Yes
E6	NOT USED			No
F7	NOT USED			No
D6	NOT USED			No
C5	NOT USED			No
A9	NOT USED			No
B8	NOT USED			No
B9	NOT USED			No
A10	NOT USED			No
G6	NOT USED			No
D13	NOT USED			No
S15	BT_WAKE			No
F11	RX_SSI_CLK	SSI_CK		Yes
B15	OPT_SEL2_OUT	R666		Yes
J13	NOT USED			Yes
J16	NOT USED			Yes
J12	NOT USED			Yes
H11	NOT USED			Yes
A5	GROUND	GROUND		No
N6	GROUND	GROUND		No
P8	GROUND	GROUND		No

Table 8.3-5. Patriot MCU/DSP (U800) Pinout (Continued)

U401 Pin Number	Description	To/From	Comment	Accessible on Main Board?
P11	GROUND	GROUND		No
M11	GROUND	GROUND		No
L15	GROUND	GROUND		No
H16	GROUND	GROUND		No
F14	GROUND	GROUND		No
G14	GROUND	GROUND		No
E13	GROUND	GROUND		No
B13	GROUND	GROUND		No
K15	GROUND	GROUND		No
D9	GROUND	GROUND		No
C8	GROUND	GROUND		No
B5	GROUND	GROUND		No
C2	GROUND	GROUND		No
C1	GROUND	GROUND		No
H3	GROUND	GROUND		No
K15	GROUND	GROUND		No
T8	GROUND	GROUND		No
H15	GROUND	GROUND		No
C9	GROUND	GROUND		No
B6	ABACUS_CS*	U401, pin 25	Active Low	Yes
E2	UNIVERSAL_SPI_CS*		Active Low	Yes
D2	NOT USED			No
E3	MAKO_CE		Active High	No
E4	SCKB	B_CLK	SPI B Clock	Yes
B1	NOT USED			No
F4	NOT USED			No
F5	SPI_MOSI_B	BMOSI	SPI B Data (VOCON)	Yes
C7	SPI_CLK_A	SCKA	SPI A Clock	Yes
C6	MOSIA	R802	SPI A Data (RF Devices)	Yes
G10	USM_SS			No

Table 8.3-5. Patriot MCU/DSP (U800) Pinout (Continued)

U401 Pin Number	Description	To/From	Comment	Accessible on Main Board?
G16	NOT USED			No
J11	CODEC_RX	R775	DSP to MAKO Rx Audio Data	Yes
A12	RX_SSI_FSYNC	SSI_FS	20 KHz pulse	Yes
A11	RX_SSI_CLK	SSI_CK	1.2 MHz	Yes
E9	TX_SSI_DATA		Data From DSP to A/D	Yes
C15	BSY_OUT_CTS*			No
F12	UTXD2			No
D15	NOT USED			No
E14	BOOT_NORM*			No
D16	RS232_USB*			No
G12	UCTS1_USB_SPEED*			No
K11	UTXD1_USB_VPO			No
K14	USB_VMO			No
K13	USB_TX_EN			No
D5	8 KHZ_INT	SYNC	8 KHz Pulse	R406
H14	BL_EN	J601, pin 43		Yes
K4	LV_DETECT	D511, pin 1	3.0V	Yes
F9	NOT USED			No
J2	SC_FILT_EN	FL200, pin 7		No
A6	16_8MHZ	C726	16.8 MHz	Yes
J7	GATED_32_KHZ	U712, pin 4	32.768 KHz	Yes
G13	NOT USED			No
J1	MOD	R634	Bootstrap mode > 2.7V	Yes
A13	NOT USED			No
M6	NOT USED			No
R1	NOT USED			No
N3	NOT USED			No
M5	NOT USED			No
P2	NOT USED			No

Table 8.3-5. Patriot MCU/DSP (U800) Pinout (Continued)

U401 Pin Number	Description	To/From	Comment	Accessible on Main Board?
P1	NOT USED			No
N1	NOT USED			No
M4	NOT USED			No
M3	NOT USED			No
M2	NOT USED			No
M1	NOT USED			No
L4	NOT USED			No
L3	NOT USED			No
L1	NOT USED			No
L2	NOT USED			No
K2	NOT USED			No
T1	NOT USED			No
R2	NOT USED			No
T2	NOT USED			No
K7	NOT USED			No
N2	NOT USED			No
L5	NOT USED			No
L6	NOT USED			No
C4	NOT USED			No
L13	NOT USED			No
D11	NOT USED			No
E16	KVL_USB_DET*		Active Low	No
F15	16.8_MHZ_OUT	16out (TP)		No
K5	NOT USED			Yes
H8	USB_ENUM			No
F16	RESET	R808	Reset = 0V	Yes
K6	USB_VPI			No
H12	BL_FREQ			No
H13	NOT USED			No
E10	DSP_DE			No
F10	MCU_DE			No

Table 8.3-5. Patriot MCU/DSP (U800) Pinout (Continued)

U401 Pin Number	Description	To/From	Comment	Accessible on Main Board?
D12	TCK	TCK	ONCE/JTAG	Yes
C13	TMS	TMS	ONCE/JTAG	Yes
E11	TRST	TRST	ONCE/JTAG	Yes
A14	TDO	TDO	ONCE/JTAG	Yes
E12	TDI	TDI	ONCE/JTAG	Yes
M16	NOT USED			No
L14	NOT USED			No
P15	NOT USED			No
L11	NOT USED			No
M14	NOT USED			No
N16	NOT USED			No
L12	NOT USED			No
M12	CKO	CKO	Disabled	Yes
N15	NOT USED			No
M15	NOT USED			No
R12	ADDRESS 0	J601, pin 7		Yes
T13	ADDRESS 1			No
M10	ADDRESS 2			No
T12	ADDRESS 3			No
P13	ADDRESS 4			No
M9	ADDRESS 5			No
P10	ADDRESS 6			No
P12	ADDRESS 7			No
N9	ADDRESS 8			No
R10	ADDRESS 9			No
P9	ADDRESS 10			No
L10	ADDRESS 11			No
T10	ADDRESS 12			No
R9	ADDRESS 13			No
L9	ADDRESS 14			No
K9	ADDRESS 15			No

Table 8.3-5. Patriot MCU/DSP (U800) Pinout (Continued)

U401 Pin Number	Description	To/From	Comment	Accessible on Main Board?
J9	ADDRESS 16			No
L8	ADDRESS 17			No
M8	ADDRESS 18			No
N8	ADDRESS 19			No
K8	ADDRESS 20			No
L7	ADDRESS 21			No
T7	ADDRESS 22			No
R7	ADDRESS 23	R814		Yes
R3	DATA 15			No
T3	DATA 14			No
N4	DATA 13			No
P4	DATA 12			No
R4	DATA 11			No
J8	DATA 10			No
T4	DATA 9			No
N5	DATA 8			No
P5	DATA 7	R644		Yes
R5	DATA 6	R643		Yes
T5	DATA 5	R642		Yes
R6	DATA 4	R641		Yes
T6	DATA 3	R640		Yes
M7	DATA 2	R639		Yes
N7	DATA 1	R638		Yes
P7	DATA 0	R637		Yes
N11	R_W			No
T11	NOT USED			No
R14	NOT USED			No
N12	CS3*			No
T14	CS2			No
R11	NOT USED			No
R15	CS0	TP_CS0	Active Low	Yes

Table 8.3-5. Patriot MCU/DSP (U800) Pinout (Continued)

U401 Pin Number	Description	To/From	Comment	Accessible on Main Board?
P16	OE_EN			No
M13	EB1_N			No
R13	EBO_N			No
N14	NOT USED			No
T16	WAIT			No
P14	NOT USED			No
N13	ADV			No
T15	B_CLK			No

Table 8.3-6. MAKO (U701) Pinout

Pin Ref Number	U701 Pin Name	To/From	Comment	Accessible on Main Board?
A4	VREF	GND	1.231	Yes
N3	UCM_SS	UCM_SS	2.9	No
P9	ONE_WIRE_1	ONE_WIRE_OPT	2.9	Yes
A5	BBP_CLK	TX_SSI_CLK	1.536MHz	Yes
H4	VCM2	GND	1/2 B+ (3.75V)	Yes
J1	EXT_MIC_M	GND	3.3V	Yes
J2	EXT_MIC_P	EXT_MIC	3.3V	Yes
J3	VCM1	GND	3.3V	Yes
K1	INT_MIC_M	GND	3.3V	Yes
K2	INT_MIC_P	INT_MIC	3.3V	Yes
B5	BBP_SYNC	TX_SSI_FSYNC	48KHz	Yes
E7	VC_DCLK	CODEC_DCLK	520Hz	Yes
L10	VMES	GND	5V	Yes
L11	ATOD_2	EMERG	5V	Yes
L2	MIC_BIAS	EXT_MIC	5V	Yes
L6	USB_CONNECT	Q704	5V	Yes
L8	ONE_WIRE_BATT	BAT_STATUS	5V	Yes
M10	TXDO_BDI_5V	RS232_DO_USB+	5V	Yes

Table 8.3-6. MAKO (U701) Pinout (Continued)

Pin Ref Number	U701 Pin Name	To/From	Comment	Accessible on Main Board?
M11	RTS_FILLSEN_5V	RTS	5V	Yes
M12	ADC_VREF	GND	5V	Yes
M13	ATOD_1	VOLUME	5V	Yes
N12	RXDIN_5V	RS232_DI_USB-	5V	Yes
N13	SB96_BUS_BUSY	SB9600_BUSY	5V	Yes
N6	USB1_DP	RS232_D0_USB+	5V	Yes
N9	SB96_BDO_KF_5V	LHDATA_KEYFAIL	5V	Yes
P13	CTS_CABLE_DET_5V	CTS	5V	Yes
P7	USB1_DM	RS232_DI_USB-	5V	Yes
D7	VC_FSYNC	CODEC_FSYNC	8KHz	Yes
F1	INT_SPKR_P	INT_SPKR_POS	B+(7.5V)	Yes
F2	INT_SPKR_M	INT_SPKR_NEG	B+(7.5V)	Yes
G1	EXT_SPKR_M	EXT_SPKR_NEG	B+(7.5V)	Yes
G2	PA_IN_P	VC_OUT_P	B+(7.5V)	Yes
G3	PA_IN_M	VC_OUT_M	B+(7.5V)	Yes
H1	EXT_SPKR_P	EXT_SPKR_POS	B+(7.5V)	Yes
H2	VC_OUT_M	PA_IN_N	B+(7.5V)	Yes
H3	VC_OUT_P	PA_IN_P	B+(7.5V)	Yes
A3	TEST	GND	GND	No
C4	SCAN_EN	GND	GND	No
E8	VFUSE	GND	GND	No
B11	AD_TRIG	ADTRIG	NA	No
B6	SPI_DI	SPI_MOSIB	NA	No
C6	SPI_DO	SPI_MISOB	NA	No
A11	TX_RX	NC	NC	No
B12	OPTION_INTX	NC	NC	No
B7	VC_TX	NC	NC	No
C10	USB_INTX	NC	NC	No
C11	OPT_GPIO1	NC	NC	No
D11	OPT_GPIO3	NC	NC	No

Table 8.3-6. MAKO (U701) Pinout (Continued)

Pin Ref Number	U701 Pin Name	To/From	Comment	Accessible on Main Board?
F10	OPT_GPIO0	NC	NC	No
G10	OPT_GPIO2	NC	NC	No
J5	TXDO_BDI_UP_3V	TXDO_BDI_ENC_3V	NC	No
K12	ATOD_7	NC	NC	No
K13	ATOD_8	NC	NC	No
K6	TXDO_BDI_ENC_3V	TXDO_BDI_UP_3V	NC	No
K7	OPTA_SEL1	NC	NC	No
K8	OPTB_SEL1	NC	NC	No
L3	FE_TUNE1	NC	NC	No
M14	ATOD_3	NC	NC	No
M2	FE_TUNE2	NC	NC	No
M3	RTS_FILLSEN_3V	NC	NC	No
M8	ONE_WIRE_2	NC	NC	No
M9	OPTA_SEL2	NC	NC	No
N1	PWR_CTRL	NC	NC	No
N10	OPTA_SEL3	NC	NC	No
N11	OPTB_SEL3	NC	NC	No
N2	RXDIN_ENC_3V	RXDIN_3V	NC	No
N7	USB2_DP	NC	NC	No
N8	SB96D_BDO_KF_3V	UART2_RXD_OD	NC	No
P10	OPTA_SEL0	NC	NC	No
P11	OPTB_SEL0	NC	NC	No
P12	OPTB_SEL2	NC	NC	No
P2	RXDIN_3V	RXDIN_ENC_3V	NC	No
P8	USB2_DM	NC	NC	No
E1	PA_BPLUS	SW_B+	SW_B+(7.5V)	Yes
E3	BPLUS	BPLUS	UNSW_B+(7.5V)	No
A7	VC_RX	CODEC_RX	V1.55(1.6V)	Yes
A6	LOGIC_VDD	V2.9	V2.9	No
A8	RS232_USB_X	RS232_USB_X	V2.9	Yes

Table 8.3-6. MAKO (U701) Pinout (Continued)

Pin Ref Number	U701 Pin Name	To/From	Comment	Accessible on Main Board?
K11	ATOD_6	V2.9	V2.9	Yes
L13	ATOD_5	V2.9	V2.9	Yes
L5	APCO	V2.9	V2.9	Yes
M4	VC_TX3V	CODEC_TX	V2.9	Yes
N14	ATOD_0	V2.9	V2.9	No
L12	ATOD_4	BAT_STATUS	VCC5(5V)	Yes
A10	UART2_RXD_OD	SB96D_BDO_KF_3V/ V2.9/URXD3	VDD(1.65-3.6V)	Yes
A9	USB2_OE_RCV_RTS	URTS1_XRXD	VDD(1.65-3.6V)	Yes
B10	CTS_X	UCTS_USB_SPEED	VDD(1.65-3.6V)	Yes
B8	USB1_OE	USB_TXENAB	VDD(1.65-3.6V)	Yes
B9	USB2_DAT_VP	USB_VPI	VDD(1.65-3.6V)	Yes
C12	BUSY_IN	BUSY_IN_RTS	VDD(1.65-3.6V)	Yes
C7	BOOT_NORM_X	BOOT_NORM_X	VDD(1.65-3.6V)	Yes
C8	USB1_DAT_TXD	TXD1_USB_VPO	VDD(1.65-3.6V)	Yes
C9	USB2_SE0_VM_RXD	URXD1_USB_VMI	VDD(1.65-3.6V)	Yes
D10	CABLE_DET_3V	KVL_USB_DET	VDD(1.65-3.6V)	Yes
D6	SPI_CS	MAKO_CE	VDD(1.65-3.6V)	Yes
D8	USB1_SE0	USB_VMO	VDD(1.65-3.6V)	Yes
E11	BUSY_OUT	BUSY_OUT_CTS	VDD(1.65-3.6V)	Yes
E6	SPI_CLK	SCKB	VDD(1.65-3.6V)	Yes
E9	UART2_TXD	UTXD2	VDD(1.65-3.6V)	Yes
L7	ONE_WIRE_UP	ONE_WIRE_UP/V2.9	VDD(1.65-3.6V)	Yes
	POWER MANAGE- MENT BLOCK			
B2	BAT_TYPE	GND	0-5V	Yes
D2	BAT_3V6	GND	0-5V	Yes
D3	REG_3V6	GND	0-5V	Yes
G4	HV_BG	GND	1.2V	Yes
M1	TXCO_IN	16_8MHz	16.8MHz (2.5-3.3V)	Yes
J13	SW2_VOUT	GND	2.3V	Yes

Table 8.3-6. MAKO (U701) Pinout (Continued)

Pin Ref Number	U701 Pin Name	To/From	Comment	Accessible on Main Board?
J14	SW2_LX	GND	2.3V	Yes
A2	PGLD03	VSAVE	2.5V	Yes
C2	VSAVE	VSAVE	2.5V	Yes
E4	MECH_SW	MECH_SW	2.5V	Yes
N5	V04_O	GND	2.775V	Yes
P6	V07_O	GND	2.8V	Yes
A12	XOUT	XTAL FREQ	24.576MHz (3.3V)	Yes
A13	XIN	XTAL FREQ	24.576MHz (3.3V)	Yes
L1	V09_O	GND	3.3V	Yes
M6	V10_O	GND	3.3V	Yes
B1	XTAL32_OUT	32.768KHz	32.768MHz (2.5-3.3V)	Yes
C1	XTAL32_IN	32.768KHz	32.768MHz (2.5-3.3V)	Yes
F5	GATED_32K_CLK	MAKO_32KHZ	32KHZ(VDD)	Yes
K4	V08_O	VCC5 SUPPLY	5V	Yes
E2	FET_ENX	VPP_EN/UNSW_B+/ SW_B+	B+(7.5V)	Yes
F14	SW1_PHASE	VSW1	B+(7.5V)	Yes
F3	BAT_RTC	GND	B+(7.5V)	Yes
B3	SW_TYPE	GND	GND	No
C3	PGLD02	GND	GND	No
D14	GND7	GND	GND	No
D4	TCXO_SEL_16_24	GND	GND	No
D9	GND9	GND	GND	No
G5	GND4	GND	GND	No
H14	SW1_GND	Q702	GND	No
H5	GND8	GND	GND	No
J4	GND3	GND	GND	No
K9	GND5	GND	GND	No
L14	SW2_GND	GND	GND	No
L4	GND6	GND	GND	No
L9	V10_GND	GND	GND	No

Table 8.3-6. MAKO (U701) Pinout (Continued)

Pin Ref Number	U701 Pin Name	To/From	Comment	Accessible on Main Board?
M7	GND2	GND	GND	No
P5	GND1	GND	GND	No
B13	VBUS_SUPPLY	NC	NC	No
B4	IGN_X	NC	NC	No
C13	VBUS2_CMD	NC	NC	No
C14	VBUS1_CMD	NC	NC	No
D12	VBUS2	NC	NC	No
D13	SW5_VDD	NC	NC	No
E12	VBUS1_SENS	NC	NC	No
E13	SW5_SUMCOMP	NC	NC	No
E14	SW5_VSENSE	NC	NC	No
F11	VBUS2_SENS	NC	NC	No
F12	SW5_VOUT	NC	NC	No
F13	SW5_VDDHV	NC	NC	No
F4	EMERG_PB	NC	NC	No
G11	SW5_PHASE	NC	NC	No
H10	VBUS1	NC	NC	No
H13	SW1_DH	NC	NC	No
J11	SW1_VSEN_BST	NC	NC	No
NC1	NC1	NC	NC	No
NC2	NC2	NC	NC	No
NC3	NC3	NC	NC	No
NC4	NC4	NC	NC	No
NC5	NC5	NC	NC	No
NC6	NC6	NC	NC	No
G12	SW1_VDDHV	SW_B+	SW_B+(7.5V)	Yes
H11	SW1_VSEN_BUK	SW_B+	SW_B+(7.5V)	Yes
K3	V08_I	SW_B+	SW_B+(7.5V)	Yes
D1	BAT_7V5	UNSW_B+	UNSW_B+(7.5V)	Yes
P4	V03_O	V1.55	V1.55(1.6V)	Yes

Table 8.3-6. MAKO (U701) Pinout (Continued)

Pin Ref Number	U701 Pin Name	To/From	Comment	Accessible on Main Board?
N4	V02_O	V1.875	V1.875	Yes
P3	V06_O	V2.9	V2.9	Yes
C5	RESETX	MAKO RESET	VDD(1.65-3.6V)	Yes
D5	INT_X	MAKO_INT_X	VDD(1.65-3.6V)	Yes
G13	SW1_VDD	Q702	VDD(1.65-3.6V)	Yes
G14	SW1_SUMCOMP_DL	Q702	VSW1 (3.6V)	Yes
H12	SW1_VOUT	VSW1	VSW1 (3.6V)	No
J10	V10_I	VSW1	VSW1 (3.6V)	Yes
J12	SW2_VCC	VSW1	VSW1 (3.6V)	Yes
K14	SW2_VCCS	VSW1	VSW1 (3.6V)	Yes

Chapter 8.4 700/800 MHz Troubleshooting Tables

8.4.1 Introduction

This chapter contains troubleshooting tables necessary to isolate a problem to the component level. Use these tables in conjunction with Chapter 4.4, 700/800 MHz Detailed Theories of Operation (page 4.4-1), Chapter 5, Troubleshooting Procedures (page 5-1), Chapter 6.4, 700/800 MHz Troubleshooting Charts (page 6.4-1), and Chapter 7.4, 700/800 MHz Troubleshooting Waveforms (page 7.4-1). This manual is to be used in conjunction with the ASTRO XTS 2500/XTS 2500I Digital Portable Radios Basic Service Manual (Motorola part number 6816984H01), which uses the pass/fail service approach to radio problems.

A blank entry in the “To/From” column of J601 indicates the signal is accessible only at J601.

8.4.2 Tables

Table 8.4-1. Main Board to Keypad Board Flex Assembly (J601)

J601 Pin Number	Description	To/From
1	V1.875	L703
2	V2.9	L704
3	UNSW_B+	R701
4	SW_B+	R708
5	HOST_WAKE	
6	WAKEUP	
7	REGISTER_SEL	
8	DISPLAY_SEL	
9	SCKB	R620
10	SPI_MOSI_B	R621
11	SPI_MISO_B	R622
12	SSI_CLK	R616
13	SSI_FSYNC	R617
14	CODEC_TX	R625
15	CODEC_RX	R626
16	KEYPAD_ROW0	
17	KEYPAD_ROW1	
18	KEYPAD_ROW2	

Table 8.4-1. Main Board to Keypad Board Flex Assembly (J601) (Continued)

J601 Pin Number	Description	To/From
19	KEYPAD_ROW3	
20	KEYPAD_ROW4	
21	KEYPAD_ROW5	
22	KEYPAD_ROW6	
23	KEYPAD_COL0	
24	KEYPAD_COL1	
25	KEYPAD_COL2	
26	DO	R637
27	D1	R638
28	D2	R639
29	D3	R640
30	D4	R641
31	D5	R642
32	D6	R643
33	D7	R644
34	KEYFAIL	
35	CKIH	C726
36	BOOT*	C726
37	TEST_TAMPER	
38	DISPLAY_RESET	R647
39	UCM_SPARE1	
40	ENC_RXD (BT_RX)	
41	ENC_TXD (BT_TX)	
42	ENC_RESET	
43	BL_EN	
44	UCM_SPARE2	
45	GROUND	
46	GROUND	
47	GROUND	

Table 8.4-2. Main Board to Universal (Side) Connector Flex Assembly (J650)

J650 Pin Number	Description	To/From	Side Connector Number
1	GND	GND (TP)	8
2	INT_SPKR+	C654	
3	INT_SPKR-	C653	
4	OPT_SEL1	R608	1
5	EXT_SPKR+	EXTSP+ (TP)	2
6	EXT_MIC	EXTMIC (TP)	3
7	OPT_B+_VPP	VPP (TP)	4
8	OPT_SEL2	R666	5
9	SPKR_COM	EXT_SP (TP)	6
10	RTS_USB_PWR	RTS1 (TP)	7
11	GND	GND(TP)	8
12	LH_BUSY	BUSY (TP)	9
13	CTS	CTS1 (TP)	10
14	RS232_TX_USB+	USB_D+ (TP)	11
15	RS232_RX_USB-	USB_D- (TP)	12
16	LH_DATA_KEYFAIL	BUS (TP)	13
17	NOT USED		
18	INT_MIC	L652	
19	GND	GND (TP)	8
20	GND	GND(TP)	8

Table 8.4-3. FLASH (U803) Pinout

U402 Pin Number	Description	To/From	Comment	Accessible on Main Board?
B4	BURSTCLK			No
E7	CS0	TP_CS0	Active Low	Yes
F8	EN_OE			No
C5	EN_WE			No
D6	WRITE PROTECT			No
C4	ADV	ADV		Yes

Table 8.4-3. FLASH (U803) Pinout (Continued)

U402 Pin Number	Description	To/From	Comment	Accessible on Main Board?
B5	RESET	CR800, pin 2	1.875V	Yes
E8	ADDRESS 1			No
D8	ADDRESS 2			No
C8	ADDRESS 3			No
B8	ADDRESS 4			No
A8	ADDRESS 5			No
B7	ADDRESS 6			No
A7	ADDRESS 7			No
C7	ADDRESS 8			No
A2	ADDRESS 9			No
B2	ADDRESS 10			No
C2	ADDRESS 11			No
A1	ADDRESS 12			No
B1	ADDRESS 13			No
C1	ADDRESS 14			No
D2	ADDRESS 15			No
D1	ADDRESS 16			No
D4	ADDRESS 17			No
B6	ADDRESS 18			No
A6	ADDRESS 19			No
C6	ADDRESS 20			No
B3	ADDRESS 21			No
C3	ADDRESS 22			No
D7	ADDRESS 23	R814		Yes
A3	GROUND			No
F1	GROUND			No
G2	GROUND			No
G8	GROUND			No
E2	DATA 15			No
F2	DATA 14			No
F3	DATA 13			No

Table 8.4-3. FLASH (U803) Pinout (Continued)

U402 Pin Number	Description	To/From	Comment	Accessible on Main Board?
D5	DATA 12			No
F4	DATA 11			No
F5	DATA 10			No
F6	DATA 9			No
G7	DATA 8			No
G1	DATA 7			No
E3	DATA 6			No
G3	DATA 5			No
E4	DATA 4			No
G5	DATA 3			No
E5	DATA 2			No
E6	DATA 1			No
F7	DATA 0			No
A5	VPP	CR801, pin 2	1.875V	Yes
G6	V1.875	C850	1.875V	Yes
E1	V1.875	C850	1.875V	Yes
G4	V1.875	C850	1.875V	Yes
A4	V1.875	C850	1.875V	Yes

Table 8.4-4. SRAM (U804) Pinout

U403 Pin Number	Description	To/From	Comment	Accessible on Main Board?
A2	EN_OE			No
G5	R_W			Yes
A1	Byte Low Enable			No
B2	Byte High Enable			No
B5	CS2			No
A6	CE2			No
A3	ADDRESS 1			No
A4	ADDRESS 2			No
A5	ADDRESS 3			No
B3	ADDRESS 4			No
B4	ADDRESS 5			No
C3	ADDRESS 6			No
C4	ADDRESS 7			No
D4	ADDRESS 8			No
H2	ADDRESS 9			No
H3	ADDRESS 10			No
H4	ADDRESS 11			No
H5	ADDRESS 12			No
G3	ADDRESS 13			No
G4	ADDRESS 14			No
F3	ADDRESS 15			No
F4	ADDRESS 16			No
E4	ADDRESS 17			No
D3	ADDRESS 18			No
H1	ADDRESS 19			No
D1	GROUND			No
E6	GROUND			No
E3	GROUND			No
H6	NOT USED			No

Table 8.4-4. SRAM (U804) Pinout (Continued)

U403 Pin Number	Description	To/From	Comment	Accessible on Main Board?
G2	NOT USED			No
G1	DATA 15			No
F1	DATA 14			No
F2	DATA 13			No
E2	DATA 12			No
D2	DATA 11			No
C2	DATA 10			No
C1	DATA 9			No
B1	DATA 8			No
G6	DATA 7	R644		Yes
F6	DATA 6	R643		Yes
F5	DATA 5	R642		Yes
E5	DATA 4	R641		Yes
D5	DATA 3	R640		Yes
C6	DATA 2	R639		Yes
C5	DATA 1	R638		Yes
B6	DATA 0	R637		Yes
D6	VSW2	C818	1.875V	Yes
E1	VSW2	C818	1.875V	Yes

Table 8.4-5. Patriot MCU/DSP (U800) Pinout

U401 Pin Number	Description	To/From	Comment	Accessible on Main Board?
H10	NOT USED			Yes
J14	NOT USED			Yes
C14	NOT USED			Yes
B14	V2.9			No
F6	ONE-WIRE_UP			Yes
E5	32K_SEL	U712, pin 6	Active Low	Yes
J6	INT_PTT	R507	Active Low	Yes

Table 8.4-5. Patriot MCU/DSP (U800) Pinout (Continued)

U401 Pin Number	Description	To/From	Comment	Accessible on Main Board?
J5	MAKO_INT*	MAKO_INT (Test Point)		Yes
J4	OPT_SEL1	U201 pin 1		Yes
J3	NOT USED			No
C16	CODEC_FSYNC	SYNC	8 KHz Pulse	Yes
G11	OPT_SEL2_IN	U601 pin 1		Yes
F1	KEYPAD_ROW0	J601, pin 16		Yes
H4	KEYPAD_ROW1	J601, pin 17		Yes
H6	KEYPAD_ROW2	J601, pin 18		Yes
G2	KEYPAD_ROW3	J601, pin 19		Yes
G11	KEYPAD_ROW4	J601, pin 20		Yes
G7	KEYPAD_ROW5	J601, pin 21		Yes
H7	KEYPAD_ROW6	J601, pin22		Yes
H1	UCM_SPARE1	J601, pin 39		Yes
D1	KEYPAD_COL0	J601, pin 23		Yes
G5	KEYPAD_COL1	J601, pin 24		Yes
F3	KEYPAD_COL2	J601, pin 25		Yes
G4	ENC_RESET	J601, pin 42		Yes
F2	BOOT*			No
E1	WAKEUP	J601, pin 6		Yes
H6	SPARE2_ENC	J601, pin 44		Yes
G3	NOT USED			No
E7	NOT USED			No
A8	HAB_MOD			No
F8	MISOA_SEL	Q801, pin 1	Data Line	Yes
E8	SB3	R510		Yes
G8	SB2	R509		Yes
C3	SB1	R508		Yes
D4	LOCK_DET	C123	Active Low	Yes
A2	NOT USED			No
B2	RTA3	VR596, pin 2		Yes

Table 8.4-5. Patriot MCU/DSP (U800) Pinout (Continued)

U401 Pin Number	Description	To/From	Comment	Accessible on Main Board?
A3	RTA2	VR593, pin 2		Yes
B3	RTA1	VR595, pin 1		Yes
B4	RTA0	VR594, pin 2		Yes
A7	V1.875	E801	1.875V	Yes
P3	V1.875	E801	1.875V	Yes
P6	V1.875	E801	1.875V	Yes
T9	V1.875	E801	1.875V	Yes
N10	V1.875	E801	1.875V	Yes
R16	V1.875	E801	1.875V	Yes
H9	V2.9	E800	3.0V	Yes
G9	V2.9	E800	3.0V	Yes
E15	V2.9	E800	3.0V	Yes
A16	V2.9	E800	3.0V	Yes
K10	V2.9	E800	3.0V	Yes
C12	V2.9	E800	3.0V	Yes
D8	V2.9	E800	3.0V	Yes
B7	V2.9	E800	3.0V	Yes
A4	V2.9	E800	3.0V	Yes
A16	V2.9	E800	3.0V	Yes
H2	V2.9	E800	3.0V	Yes
K3	V1.875	E801	1.875V	Yes
R8	V1.875	E801	1.875V	Yes
G15	V1.875	E801	1.875V	Yes
C10	V1.875	E801	1.875V	Yes
K12	URXD1_USB_VMI			No
L16	URTS1_XRXD			No
F13	ADTRIG			No
B16	P-URXD2			No
D14	P-URTS2			No
B12	RX_SSI_DATA	TP403	Data From Abacus to DSP	Yes

Table 8.4-5. Patriot MCU/DSP (U800) Pinout (Continued)

U401 Pin Number	Description	To/From	Comment	Accessible on Main Board?
C11	TX_SSI_CLK	R259	1.536 MHz	Yes
B10	RED_LED	Q501, pin 3	Active High	Yes
D10	GREEN_LED	Q501, pin 5	Active High	Yes
B11	TX_SSI_FSYNC	R251	48 KHz	Yes
J10	CODEC_TX	TX	MAKO to DSP Tx Audio Data	Yes
J15	CODEC_DCLK	DCLK	512 KHz	Yes
K16	CODEC_FSYNC	SYNC	8 KHz Pulse	Yes
D7	MISOA	U801, pin 4	SPI A Data Out	Yes
D3	MISOB	BMISO	SPI B Data Out	Yes
E6	NOT USED			No
F7	NOT USED			No
D6	NOT USED			No
C5	NOT USED			No
A9	NOT USED			No
B8	NOT USED			No
B9	NOT USED			No
A10	NOT USED			No
G6	BT_DISABLE			No
D13	NOT USED			No
S15	BT_WAKE			No
F11	RX_SSI_CLK	SSI_CK		Yes
B15	OPT_SEL2_OUT	R666		Yes
J13	NOT USED			Yes
J16	NOT USED			Yes
J12	NOT USED			Yes
H11	NOT USED			Yes
A5	GROUND	GROUND		No
N6	GROUND	GROUND		No
P8	GROUND	GROUND		No

Table 8.4-5. Patriot MCU/DSP (U800) Pinout (Continued)

U401 Pin Number	Description	To/From	Comment	Accessible on Main Board?
P11	GROUND	GROUND		No
M11	GROUND	GROUND		No
L15	GROUND	GROUND		No
H16	GROUND	GROUND		No
F14	GROUND	GROUND		No
G14	GROUND	GROUND		No
E13	GROUND	GROUND		No
B13	GROUND	GROUND		No
K15	GROUND	GROUND		No
D9	GROUND	GROUND		No
C8	GROUND	GROUND		No
B5	GROUND	GROUND		No
C2	GROUND	GROUND		No
C1	GROUND	GROUND		No
H3	GROUND	GROUND		No
K15	GROUND	GROUND		No
T8	GROUND	GROUND		No
H15	GROUND	GROUND		No
C9	GROUND	GROUND		No
B6	ABACUS_CS*	U401, pin 25	Active Low	Yes
E2	UNIVERSAL_SPI_CS*	C222	Active Low	Yes
D2	NOT USED			No
E3	MAKO_CE		Active High	No
E4	SCKB	B_CLK	SPI B Clock	Yes
B1	NOT USED			No
F4	NOT USED			No
F5	SPI_MOSI_B	BMOSI	SPI B Data (VOCON)	Yes
C7	SPI_CLK_A	SCKA	SPI A Clock	Yes
C6	MOSIA	R802	SPI A Data (RF Devices)	Yes
G10	NOT USED			No

Table 8.4-5. Patriot MCU/DSP (U800) Pinout (Continued)

U401 Pin Number	Description	To/From	Comment	Accessible on Main Board?
G16	NOT USED			No
J11	CODEC_RX	R775	DSP to MAKO Rx Audio Data	Yes
A12	RX_SSI_FSYNC	SSI_FS	20 KHz pulse	Yes
A11	RX_SSI_CLK	SSI_CK	1.2 MHz	Yes
E9	TX_SSI_DATA	U201, pin 4	Data From DSP to A/D	Yes
C15	BSY_OUT_CTS*			No
F12	UTXD2			No
D15	NOT USED			No
E14	BOOT_NORM*			No
D16	RS232_USB*			No
G12	UCTS1_USB_SPEED*			No
K11	UTXD1_USB_VPO			No
K14	USB_VMO			No
K13	USB_TX_EN			No
D5	8 KHZ_INT	SYNC	8 KHz Pulse	R406
H14	BL_EN	J601, pin 43		Yes
K4	LV_DETECT	D511, pin 1	3.0V	Yes
F9	NOT USED			No
J2	SC_FILT_EN	FL200, pin 7		No
A6	16_8MHZ	C726	16.8 MHz	Yes
J7	GATED_32_KHZ	U712, pin 4	32.768 KHz	Yes
G13	NOT USED			No
J1	MOD	R634	Bootstrap mode > 2.7V	Yes
A13	NOT USED			No
M6	NOT USED			No
R1	NOT USED			No
N3	NOT USED			No
M5	NOT USED			No
P2	NOT USED			No

Table 8.4-5. Patriot MCU/DSP (U800) Pinout (Continued)

U401 Pin Number	Description	To/From	Comment	Accessible on Main Board?
P1	NOT USED			No
N1	NOT USED			No
M4	NOT USED			No
M3	NOT USED			No
M2	NOT USED			No
M1	NOT USED			No
L4	NOT USED			No
L3	NOT USED			No
L1	NOT USED			No
L2	NOT USED			No
K2	NOT USED			No
T1	NOT USED			No
R2	NOT USED			No
T2	NOT USED			No
K7	NOT USED			No
N2	NOT USED			No
L5	NOT USED			No
L6	NOT USED			No
C4	NOT USED			No
L13	NOT USED			No
D11	NOT USED			No
E16	KVL_USB_DET*		Active Low	No
F15	16.8_MHZ_OUT	16out (TP)		No
K5	NOT USED			Yes
H8	NOT USED			No
F16	RESET	R808	Reset = 0V	Yes
K6	USB_VPI			No
H12	BL_FREQ			No
H13	NOT USED			No
E10	NOT USED			No
F10	NOT USED			No

Table 8.4-5. Patriot MCU/DSP (U800) Pinout (Continued)

U401 Pin Number	Description	To/From	Comment	Accessible on Main Board?
D12	TCK	TCK	ONCE/JTAG	Yes
C13	TMS	TMS	ONCE/JTAG	Yes
E11	TRST	TRST	ONCE/JTAG	Yes
A14	TDO	TDO	ONCE/JTAG	Yes
E12	TDI	TDI	ONCE/JTAG	Yes
M16	NOT USED			No
L14	NOT USED			No
P15	NOT USED			No
L11	NOT USED			No
M14	NOT USED			No
N16	NOT USED			No
L12	NOT USED			No
M12	CKO	CKO	Disabled	Yes
N15	NOT USED			No
M15	NOT USED			No
R12	ADDRESS 0	J601, pin 7		Yes
T13	ADDRESS 1			No
M10	ADDRESS 2			No
T12	ADDRESS 3			No
P13	ADDRESS 4			No
M9	ADDRESS 5			No
P10	ADDRESS 6			No
P12	ADDRESS 7			No
N9	ADDRESS 8			No
R10	ADDRESS 9			No
P9	ADDRESS 10			No
L10	ADDRESS 11			No
T10	ADDRESS 12			No
R9	ADDRESS 13			No
L9	ADDRESS 14			No
K9	ADDRESS 15			No

Table 8.4-5. Patriot MCU/DSP (U800) Pinout (Continued)

U401 Pin Number	Description	To/From	Comment	Accessible on Main Board?
J9	ADDRESS 16			No
L8	ADDRESS 17			No
M8	ADDRESS 18			No
N8	ADDRESS 19			No
K8	ADDRESS 20			No
L7	ADDRESS 21			No
T7	ADDRESS 22			No
R7	ADDRESS 23	R814		Yes
R3	DATA 15			No
T3	DATA 14			No
N4	DATA 13			No
P4	DATA 12			No
R4	DATA 11			No
J8	DATA 10			No
T4	DATA 9			No
N5	DATA 8			No
P5	DATA 7	R644		Yes
R5	DATA 6	R643		Yes
T5	DATA 5	R642		Yes
R6	DATA 4	R641		Yes
T6	DATA 3	R640		Yes
M7	DATA 2	R639		Yes
N7	DATA 1	R638		Yes
P7	DATA 0	R637		Yes
N11	R_W			No
T11	NOT USED			No
R14	NOT USED			No
N12	CS3*			No
T14	CS2			No
R11	NOT USED			No
R15	CS0	TP_CS0	Active Low	Yes

Table 8.4-5. Patriot MCU/DSP (U800) Pinout (Continued)

U401 Pin Number	Description	To/From	Comment	Accessible on Main Board?
P16	OE_EN			No
M13	EB1_N			No
R13	EBO_N			No
N14	NOT USED			No
T16	WAIT			No
P14	NOT USED			No
N13	ADV			No
T15	B_CLK			No

Table 8.4-6. MAKO (U701) Pinout

Pin Ref Number	U701 Pin Name	To/From	Comment	Accessible on Main Board?
A4	VREF	GND	1.231	Yes
N3	UCM_SS	UCM_SS	2.9	No
P9	ONE_WIRE_1	ONE_WIRE_OPT	2.9	Yes
A5	BBP_CLK	TX_SSI_CLK	1.536MHz	Yes
H4	VCM2	GND	1/2 B+ (3.75V)	Yes
J1	EXT_MIC_M	GND	3.3V	Yes
J2	EXT_MIC_P	EXT_MIC	3.3V	Yes
J3	VCM1	GND	3.3V	Yes
K1	INT_MIC_M	GND	3.3V	Yes
K2	INT_MIC_P	INT_MIC	3.3V	Yes
B5	BBP_SYNC	TX_SSI_FSYNC	48KHz	Yes
E7	VC_DCLK	CODEC_DCLK	520Hz	Yes
L10	VMES	GND	5V	Yes
L11	ATOD_2	EMERG	5V	Yes
L2	MIC_BIAS	EXT_MIC	5V	Yes
L6	USB_CONNECT	Q704	5V	Yes
L8	ONE_WIRE_BATT	BAT_STATUS	5V	Yes
M10	TXDO_BDI_5V	RS232_DO_USB+	5V	Yes

Table 8.4-6. MAKO (U701) Pinout (Continued)

Pin Ref Number	U701 Pin Name	To/From	Comment	Accessible on Main Board?
M11	RTS_FILLSEN_5V	RTS	5V	Yes
M12	ADC_VREF	GND	5V	Yes
M13	ATOD_1	VOLUME	5V	Yes
N12	RXDIN_5V	RS232_DI_USB-	5V	Yes
N13	SB96_BUS_BUSY	SB9600_BUSY	5V	Yes
N6	USB1_DP	RS232_DI_USB-	5V	Yes
N9	SB96_BDO_KF_5V	LHDATA_KEYFAIL	5V	Yes
P13	CTS_CABLE_DET_5V	CTS	5V	Yes
P7	USB1_DM	RS232_DI_USB+	5V	Yes
D7	VC_FSYNC	CODEC_FSYNC	8KHz	Yes
F1	INT_SPKR_P	INT_SPKR_POS	B+(7.5V)	Yes
F2	INT_SPKR_M	INT_SPKR_NEG	B+(7.5V)	Yes
G1	EXT_SPKR_M	EXT_SPKR_NEG	B+(7.5V)	Yes
G2	PA_IN_P	VC_OUT_P	B+(7.5V)	Yes
G3	PA_IN_M	VC_OUT_N	B+(7.5V)	Yes
H1	EXT_SPKR_P	EXT_SPKR_POS	B+(7.5V)	Yes
H2	VC_OUT_M	PA_IN_N	B+(7.5V)	Yes
H3	VC_OUT_P	PA_IN_P	B+(7.5V)	Yes
A3	TEST	GND	GND	No
C4	SCAN_EN	GND	GND	No
E8	VFUSE	GND	GND	No
B11	AD_TRIG	ADTRIG	NA	No
B6	SPI_DI	SPI_MOSIB	NA	No
C6	SPI_DO	SPI_MISOB	NA	No
A11	TX_RX	NC	NC	No
B12	OPTION_INTX	NC	NC	No
B7	VC_TX	NC	NC	No
C10	USB_INTX	NC	NC	No
C11	OPT_GPIO1	NC	NC	No
D11	OPT_GPIO3	NC	NC	No

Table 8.4-6. MAKO (U701) Pinout (Continued)

Pin Ref Number	U701 Pin Name	To/From	Comment	Accessible on Main Board?
F10	OPT_GPIO0	NC	NC	No
G10	OPT_GPIO2	NC	NC	No
J5	TXDO_BDI_UP_3V	NC	NC	No
K12	ATOD_7	NC	NC	No
K13	ATOD_8	NC	NC	No
K6	TXDO_BDI_ENC_3V	NC	NC	No
K7	OPTA_SEL1	NC	NC	No
K8	OPTB_SEL1	NC	NC	No
L3	FE_TUNE1	NC	NC	No
M14	ATOD_3	NC	NC	No
M2	FE_TUNE2	NC	NC	No
M3	RTS_FILLSEN_3V	NC	NC	No
M8	ONE_WIRE_2	NC	NC	No
M9	OPTA_SEL2	NC	NC	No
N1	PWR_CTRL	NC	NC	No
N10	OPTA_SEL3	NC	NC	No
N11	OPTB_SEL3	NC	NC	No
N2	RXDIN_ENC_3V	NC	NC	No
N7	USB2_DP	NC	NC	No
N8	SB96D_BDO_KF_3V	NC	NC	No
P10	OPTA_SEL0	NC	NC	No
P11	OPTB_SEL0	NC	NC	No
P12	OPTB_SEL2	NC	NC	No
P2	RXDIN_3V	NC	NC	No
P8	USB2_DN	NC	NC	No
E1	PA_BPLUS	SW_B+	SW_B+(7.5V)	Yes
E3	BPLUS	BPLUS	UNSW_B+(7.5V)	No
A7	VC_RX	CODEC_RX	V1.55(1.6V)	Yes
A6	LOGIC_VDD	V2.9	V2.9	No
A8	RS232_USB_X	RS232_USB_X	V2.9	Yes

Table 8.4-6. MAKO (U701) Pinout (Continued)

Pin Ref Number	U701 Pin Name	To/From	Comment	Accessible on Main Board?
K11	ATOD_6	V2.9	V2.9	Yes
L13	ATOD_5	V2.9	V2.9	Yes
L5	APCO	V2.9	V2.9	Yes
M4	VC_TX3V	CODEC_TX	V2.9	Yes
N14	ATOD_0	V2.9	V2.9	No
L12	ATOD_4	BAT_STATUS	VCC5(5V)	Yes
A10	UART2_RXD_OD	SB96D_BDO_KF_3V/ V2.9/URXD3	VDD(1.65-3.6V)	Yes
A9	USB2_OE_RCV_RTS	URTS1_XRXD	VDD(1.65-3.6V)	Yes
B10	CTS_X	UCTS_USB_SPEED	VDD(1.65-3.6V)	Yes
B8	USB1_OE	USB_TXENAB	VDD(1.65-3.6V)	Yes
B9	USB2_DAT_VP	USB_VPI	VDD(1.65-3.6V)	Yes
C12	BUSY_IN	URTS2	VDD(1.65-3.6V)	Yes
C7	BOOT_NORM_X	BOOT_NORM_X	VDD(1.65-3.6V)	Yes
C8	USB1_DAT_TXD	TXD1_USB_VPO	VDD(1.65-3.6V)	Yes
C9	USB2_SE0_VM_RXD	URXD1_USB_VMI	VDD(1.65-3.6V)	Yes
D10	CABLE_DET_3V	KVL_USB_DET	VDD(1.65-3.6V)	Yes
D6	SPI_CS	MAKO_CE	VDD(1.65-3.6V)	Yes
D8	USB1_SE0	USB_VMO	VDD(1.65-3.6V)	Yes
E11	BUSY_OUT	UCTS2	VDD(1.65-3.6V)	Yes
E6	SPI_CLK	SCKB	VDD(1.65-3.6V)	Yes
E9	UART2_TXD	UTXD2	VDD(1.65-3.6V)	Yes
L7	ONE_WIRE_UP	ONE_WIRE_UP/V2.9	VDD(1.65-3.6V)	Yes
	POWER MANAGE- MENT BLOCK			
B2	BAT_TYPE	GND	0-5V	Yes
D2	BAT_3V6	GND	0-5V	Yes
D3	REG_3V6	GND	0-5V	Yes
G4	HV_BG	GND	1.2V	Yes
M1	TXCO_IN	16_8MHz	16.8MHz (2.5-3.3V)	Yes
J13	SW2_VOUT	GND	2.3V	Yes

Table 8.4-6. MAKO (U701) Pinout (Continued)

Pin Ref Number	U701 Pin Name	To/From	Comment	Accessible on Main Board?
J14	SW2_LX	GND	2.3V	Yes
A2	PGLD03	VSAVE	2.5V	Yes
C2	VSAVE	VSAVE	2.5V	Yes
E4	MECH_SW	SW_B+	2.5V	Yes
N5	V04_O	GND	2.775V	Yes
P6	V07_O	GND	2.8V	Yes
A12	XOUT	XTAL FREQ	24.576MHz (3.3V)	Yes
A13	XIN	XTAL FREQ	24.576MHz (3.3V)	Yes
L1	V09_O	GND	3.3V	Yes
M6	V10_O	GND	3.3V	Yes
B1	XTAL32_OUT	32.768KHz	32.768MHz (2.5-3.3V)	Yes
C1	XTAL32_IN	32.768KHz	32.768MHz (2.5-3.3V)	Yes
F5	GATED_32K_CLK	MAKO_32KHZ	32KHZ(VDD)	Yes
K4	V08_O	VCC5 SUPPLY	5V	Yes
E2	FET_ENX	VPP_EN/UNSW_B+/ SW_B+	B+(7.5V)	Yes
F14	SW1_PHASE	VSW1	B+(7.5V)	Yes
F3	BAT_RTC	GND	B+(7.5V)	Yes
B3	SW_TYPE	GND	GND	No
C3	PGLD02	GND	GND	No
D14	GND7	GND	GND	No
D4	TCXO_SEL_16_24	GND	GND	No
D9	GND9	GND	GND	No
G5	GND4	GND	GND	No
H14	SW1_GND	Q502	GND	No
H5	GND8	GND	GND	No
J4	GND3	GND	GND	No
K9	GND5	GND	GND	No
L14	SW2_GND	GND	GND	No
L4	GND6	GND	GND	No
L9	V10_GND	GND	GND	No

Table 8.4-6. MAKO (U701) Pinout (Continued)

Pin Ref Number	U701 Pin Name	To/From	Comment	Accessible on Main Board?
M7	GND2	GND	GND	No
P5	GND1	GND	GND	No
B13	VBUS_SUPPLY	NC	NC	No
B4	IGN_X	NC	NC	No
C13	VBUS2_CMD	NC	NC	No
C14	VBUS1_CMD	NC	NC	No
D12	VBUS2	NC	NC	No
D13	SW5_VDD	NC	NC	No
E12	VBUS1_SENS	NC	NC	No
E13	SW5_SUMCOMP	NC	NC	No
E14	SW5_VSENSE	NC	NC	No
F11	VBUS2_SENS	NC	NC	No
F12	SW5_VOUT	NC	NC	No
F13	SW5_VDDHV	NC	NC	No
F4	EMERG_PB	NC	NC	No
G11	SW5_PHASE	NC	NC	No
H10	VBUS1	NC	NC	No
H13	SW1_DH	NC	NC	No
J11	SW1_VSEN_BST	NC	NC	No
NC1	NC1	NC	NC	No
NC2	NC2	NC	NC	No
NC3	NC3	NC	NC	No
NC4	NC4	NC	NC	No
NC5	NC5	NC	NC	No
NC6	NC6	NC	NC	No
G12	SW1_VDDHV	SW_B+	SW_B+(7.5V)	Yes
H11	SW1_VSEN_BUK	SW_B+	SW_B+(7.5V)	Yes
K3	V08_I	SW_B+	SW_B+(7.5V)	Yes
D1	BAT_7V5	UNSW_B+	UNSW_B+(7.5V)	Yes
P4	V03_O	V1.55	V1.55(1.6V)	Yes

Table 8.4-6. MAKO (U701) Pinout (Continued)

Pin Ref Number	U701 Pin Name	To/From	Comment	Accessible on Main Board?
N4	V02_O	V1.875	V1.875	Yes
P3	V06_O	V2.9	V2.9	Yes
C5	RESETX	MAKO RESET	VDD(1.65-3.6V)	Yes
D5	INT_X	MAKO_INT_X	VDD(1.65-3.6V)	Yes
G13	SW1_VDD	Q702	VDD(1.65-3.6V)	Yes
G14	SW1_SUMCOMP_DL	Q702	VSW1 (3.6V)	Yes
H12	SW1_VOUT	VSW1	VSW1 (3.6V)	No
J10	V10_I	VSW1	VSW1 (3.6V)	Yes
J12	SW2_VCC	VSW1	VSW1 (3.6V)	Yes
K14	SW2_VCCS	VSW1	VSW1 (3.6V)	Yes

Chapter 8.5 900MHz Troubleshooting Tables

8.5.1 Introduction

This chapter contains troubleshooting tables necessary to isolate a problem to the component level. Use these tables in conjunction with Chapter 4.5, 900 MHz Detailed Theories of Operation (page 4.5-1), Chapter 5, Troubleshooting Procedures (page 5-1), Chapter 6.5, 900 MHz Troubleshooting Charts (page 6.5-1), and Chapter 7.5, Troubleshooting Waveforms (page 7.5-1). This manual is to be used in conjunction with the ASTRO XTS 2500/XTS 2500I Digital Portable Radios Basic Service Manual (Motorola part number 6816984H01), which uses the pass/fail service approach to radio problems.

A blank entry in the “To/From” column of J601 indicates the signal is accessible only at J601.

8.5.2 Tables

Table 8.5-1. Main Board to Keypad Board Flex Assembly (J601)

J601 Pin Number	Description	To/From
1	V1.875	L703
2	V2.9	L704
3	UNSW_B+	R701
4	SW_B+	R708
5	HOST_WAKE	
6	WAKEUP	
7	REGISTER_SEL	
8	DISPLAY_SEL	
9	SCKB	R620
10	SPI_MOSI_B	R621
11	SPI_MISO_B	R622
12	SSI_CLK	R616
13	SSI_FSYNC	R617
14	CODEC_TX	R625
15	CODEC_RX	R626
16	KEYPAD_ROW0	
17	KEYPAD_ROW1	
18	KEYPAD_ROW2	

Table 8.5-1. Main Board to Keypad Board Flex Assembly (J601) (Continued)

J601 Pin Number	Description	To/From
19	KEYPAD_ROW3	
20	KEYPAD_ROW4	
21	KEYPAD_ROW5	
22	KEYPAD_ROW6	
23	KEYPAD_COL0	
24	KEYPAD_COL1	
25	KEYPAD_COL2	
26	DO	R637
27	D1	R638
28	D2	R639
29	D3	R640
30	D4	R641
31	D5	R642
32	D6	R643
33	D7	R644
34	KEYFAIL	
35	CKIH	C726
36	BOOT*	C726
37	TEST_TAMPER	
38	DISPLAY_RESET	R647
39	UCM_SPARE1	
40	ENC_RXD (BT_RX)	
41	ENC_TXD (BT_TX)	
42	ENC_RESET	
43	BL_EN	
44	UCM_SPARE2	
45	GROUND	
46	GROUND	
47	GROUND	

Table 8.5-2. Main Board to Universal (Side) Connector Flex Assembly (J650)

J650 Pin Number	Description	To/From	Side Connector Number
1	GND	GND (TP)	8
2	INT_SPKR+	C654	
3	INT_SPKR-	C653	
4	OPT_SEL1	R608	1
5	EXT_SPKR+	EXTSP+ (TP)	2
6	EXT_MIC	EXTMIC (TP)	3
7	OPT_B+_VPP	VPP (TP)	4
8	OPT_SEL2	R666	5
9	SPKR_COM	EXT_SP (TP)	6
10	RTS_USB_PWR	RTS1 (TP)	7
11	GND	GND(TP)	8
12	LH_BUSY	BUSY (TP)	9
13	CTS	CTS1 (TP)	10
14	RS232_TX_USB+	USB_D+ (TP)	11
15	RS232_RX_USB-	USB_D- (TP)	12
16	LH_DATA_KEYFAIL	BUS (TP)	13
17	NOT USED		
18	INT_MIC	L652	
19	GND	GND (TP)	8
20	GND	GND(TP)	8

Table 8.5-3. FLASH (U803) Pinout

U402 Pin Number	Description	To/From	Comment	Accessible on Main Board?
B4	BURSTCLK			No
E7	CS0	TP_CS0	Active Low	Yes
F8	EN_OE			No
C5	EN_WE			No
D6	WRITE PROTECT			No
C4	ADV	ADV		Yes

Table 8.5-3. FLASH (U803) Pinout (Continued)

U402 Pin Number	Description	To/From	Comment	Accessible on Main Board?
B5	RESET	CR800, pin 2	1.875V	Yes
E8	ADDRESS 1			No
D8	ADDRESS 2			No
C8	ADDRESS 3			No
B8	ADDRESS 4			No
A8	ADDRESS 5			No
B7	ADDRESS 6			No
A7	ADDRESS 7			No
C7	ADDRESS 8			No
A2	ADDRESS 9			No
B2	ADDRESS 10			No
C2	ADDRESS 11			No
A1	ADDRESS 12			No
B1	ADDRESS 13			No
C1	ADDRESS 14			No
D2	ADDRESS 15			No
D1	ADDRESS 16			No
D4	ADDRESS 17			No
B6	ADDRESS 18			No
A6	ADDRESS 19			No
C6	ADDRESS 20			No
B3	ADDRESS 21			No
C3	ADDRESS 22			No
D7	ADDRESS 23	R814		Yes
A3	GROUND			No
F1	GROUND			No
G2	GROUND			No
G8	GROUND			No
E2	DATA 15			No
F2	DATA 14			No
F3	DATA 13			No

Table 8.5-3. FLASH (U803) Pinout (Continued)

U402 Pin Number	Description	To/From	Comment	Accessible on Main Board?
D5	DATA 12			No
F4	DATA 11			No
F5	DATA 10			No
F6	DATA 9			No
G7	DATA 8			No
G1	DATA 7			No
E3	DATA 6			No
G3	DATA 5			No
E4	DATA 4			No
G5	DATA 3			No
E5	DATA 2			No
E6	DATA 1			No
F7	DATA 0			No
A5	VPP	CR801, pin 2	1.875V	Yes
G6	V1.875	C850	1.875V	Yes
E1	V1.875	C850	1.875V	Yes
G4	V1.875	C850	1.875V	Yes
A4	V1.875	C850	1.875V	Yes

Table 8.5-4. SRAM (U804) Pinout

U403 Pin Number	Description	To/From	Comment	Accessible on Main Board?
A2	EN_OE			No
G5	R_W			Yes
A1	Byte Low Enable			No
B2	Byte High Enable			No
B5	CS2			No
A6	CE2			No
A3	ADDRESS 1			No
A4	ADDRESS 2			No
A5	ADDRESS 3			No
B3	ADDRESS 4			No
B4	ADDRESS 5			No
C3	ADDRESS 6			No
C4	ADDRESS 7			No
D4	ADDRESS 8			No
H2	ADDRESS 9			No
H3	ADDRESS 10			No
H4	ADDRESS 11			No
H5	ADDRESS 12			No
G3	ADDRESS 13			No
G4	ADDRESS 14			No
F3	ADDRESS 15			No
F4	ADDRESS 16			No
E4	ADDRESS 17			No
D3	ADDRESS 18			No
H1	ADDRESS 19			No
D1	GROUND			No
E6	GROUND			No
E3	GROUND			No
H6	NOT USED			No

Table 8.5-4. SRAM (U804) Pinout (Continued)

U403 Pin Number	Description	To/From	Comment	Accessible on Main Board?
G2	NOT USED			No
G1	DATA 15			No
F1	DATA 14			No
F2	DATA 13			No
E2	DATA 12			No
D2	DATA 11			No
C2	DATA 10			No
C1	DATA 9			No
B1	DATA 8			No
G6	DATA 7	R644		Yes
F6	DATA 6	R643		Yes
F5	DATA 5	R642		Yes
E5	DATA 4	R641		Yes
D5	DATA 3	R640		Yes
C6	DATA 2	R639		Yes
C5	DATA 1	R638		Yes
B6	DATA 0	R637		Yes
D6	VSW2	C818	1.875V	Yes
E1	VSW2	C818	1.875V	Yes

Table 8.5-5. Patriot MCU/DSP (U800) Pinout

U401 Pin Number	Description	To/From	Comment	Accessible on Main Board?
H10	NOT USED			Yes
J14	NOT USED			Yes
C14	NOT USED			Yes
B14	V2.9			No
F6	ONE-WIRE_UP			Yes
E5	32K_SEL	U712, pin 6	Active Low	Yes
J6	INT_PTT	R507	Active Low	Yes

Table 8.5-5. Patriot MCU/DSP (U800) Pinout (Continued)

U401 Pin Number	Description	To/From	Comment	Accessible on Main Board?
J5	MAKO_INT*	MAKO_INT (Test Point)		Yes
J4	OPT_SEL1	U201 pin 1		Yes
J3	NOT USED			No
C16	CODEC_FSYNC	SYNC	8 KHz Pulse	Yes
G11	OPT_SEL2_IN	U601 pin 1		Yes
F1	KEYPAD_ROW0	J601, pin 16		Yes
H4	KEYPAD_ROW1	J601, pin 17		Yes
H6	KEYPAD_ROW2	J601, pin 18		Yes
G2	KEYPAD_ROW3	J601, pin 19		Yes
G11	KEYPAD_ROW4	J601, pin 20		Yes
G7	KEYPAD_ROW5	J601, pin 21		Yes
H7	KEYPAD_ROW6	J601, pin22		Yes
H1	UCM_SPARE1	J601, pin 39		Yes
D1	KEYPAD_COL0	J601, pin 23		Yes
G5	KEYPAD_COL1	J601, pin 24		Yes
F3	KEYPAD_COL2	J601, pin 25		Yes
G4	ENC_RESET	J601, pin 42		Yes
F2	BOOT*			No
E1	WAKEUP	J601, pin 6		Yes
H6	SPARE2_ENC	J601, pin 44		Yes
G3	NOT USED			No
E7	NOT USED			No
A8	HAB_MOD			No
F8	MISOA_SEL	Q801, pin 1	Data Line	Yes
E8	SB3	R510		Yes
G8	SB2	R509		Yes
C3	SB1	R508		Yes
D4	LOCK_DET	C123	Active Low	Yes
A2	NOT USED			No
B2	RTA3	VR596, pin 2		Yes

Table 8.5-5. Patriot MCU/DSP (U800) Pinout (Continued)

U401 Pin Number	Description	To/From	Comment	Accessible on Main Board?
A3	RTA2	VR593, pin 2		Yes
B3	RTA1	VR595, pin 1		Yes
B4	RTA0	VR594, pin 2		Yes
A7	V1.875	E801	1.875V	Yes
P3	V1.875	E801	1.875V	Yes
P6	V1.875	E801	1.875V	Yes
T9	V1.875	E801	1.875V	Yes
N10	V1.875	E801	1.875V	Yes
R16	V1.875	E801	1.875V	Yes
H9	V2.9	E800	3.0V	Yes
G9	V2.9	E800	3.0V	Yes
E15	V2.9	E800	3.0V	Yes
A16	V2.9	E800	3.0V	Yes
K10	V2.9	E800	3.0V	Yes
C12	V2.9	E800	3.0V	Yes
D8	V2.9	E800	3.0V	Yes
B7	V2.9	E800	3.0V	Yes
A4	V2.9	E800	3.0V	Yes
A16	V2.9	E800	3.0V	Yes
H2	V2.9	E800	3.0V	Yes
K3	V1.875	E801	1.875V	Yes
R8	V1.875	E801	1.875V	Yes
G15	V1.875	E801	1.875V	Yes
C10	V1.875	E801	1.875V	Yes
K12	URXD1_USB_VMI			No
L16	URTS1_XRXD			No
F13	ADTRIG			No
B16	P-URXD2			No
D14	P-URTS2			No
B12	RX_SSI_DATA	TP403	Data From Abacus to DSP	Yes

Table 8.5-5. Patriot MCU/DSP (U800) Pinout (Continued)

U401 Pin Number	Description	To/From	Comment	Accessible on Main Board?
C11	TX_SSI_CLK	R259	1.536 MHz	Yes
B10	RED_LED	Q501, pin 3	Active High	Yes
D10	GREEN_LED	Q501, pin 5	Active High	Yes
B11	TX_SSI_FSYNC	R251	48 KHz	Yes
J10	CODEC_TX	TX	MAKO to DSP Tx Audio Data	Yes
J15	CODEC_DCLK	DCLK	512 KHz	Yes
K16	CODEC_FSYNC	SYNC	8 KHz Pulse	Yes
D7	MISOA	U801, pin 4	SPI A Data Out	Yes
D3	MISOB	BMISO	SPI B Data Out	Yes
E6	NOT USED			No
F7	NOT USED			No
D6	NOT USED			No
C5	NOT USED			No
A9	NOT USED			No
B8	NOT USED			No
B9	NOT USED			No
A10	NOT USED			No
G6	BT_DISABLE			No
D13	NOT USED			No
S15	BT_WAKE			No
F11	RX_SSI_CLK	SSI_CK		Yes
B15	OPT_SEL2_OUT	R666		Yes
J13	NOT USED			Yes
J16	NOT USED			Yes
J12	NOT USED			Yes
H11	NOT USED			Yes
A5	GROUND	GROUND		No
N6	GROUND	GROUND		No
P8	GROUND	GROUND		No

Table 8.5-5. Patriot MCU/DSP (U800) Pinout (Continued)

U401 Pin Number	Description	To/From	Comment	Accessible on Main Board?
P11	GROUND	GROUND		No
M11	GROUND	GROUND		No
L15	GROUND	GROUND		No
H16	GROUND	GROUND		No
F14	GROUND	GROUND		No
G14	GROUND	GROUND		No
E13	GROUND	GROUND		No
B13	GROUND	GROUND		No
K15	GROUND	GROUND		No
D9	GROUND	GROUND		No
C8	GROUND	GROUND		No
B5	GROUND	GROUND		No
C2	GROUND	GROUND		No
C1	GROUND	GROUND		No
H3	GROUND	GROUND		No
K15	GROUND	GROUND		No
T8	GROUND	GROUND		No
H15	GROUND	GROUND		No
C9	GROUND	GROUND		No
B6	ABACUS_CS*	U401, pin 25	Active Low	Yes
E2	UNIVERSAL_SPI_CS*	C222	Active Low	Yes
D2	NOT USED			No
E3	MAKO_CE		Active High	No
E4	SCKB	B_CLK	SPI B Clock	Yes
B1	NOT USED			No
F4	NOT USED			No
F5	SPI_MOSI_B	BMOSI	SPI B Data (VOCON)	Yes
C7	SPI_CLK_A	SCKA	SPI A Clock	Yes
C6	MOSIA	R802	SPI A Data (RF Devices)	Yes
G10	NOT USED			No

Table 8.5-5. Patriot MCU/DSP (U800) Pinout (Continued)

U401 Pin Number	Description	To/From	Comment	Accessible on Main Board?
G16	NOT USED			No
J11	CODEC_RX	R775	DSP to MAKO Rx Audio Data	Yes
A12	RX_SSI_FSYNC	SSI_FS	20 KHz pulse	Yes
A11	RX_SSI_CLK	SSI_CK	1.2 MHz	Yes
E9	TX_SSI_DATA	U201, pin 4	Data From DSP to A/D	Yes
C15	BSY_OUT_CTS*			No
F12	UTXD2			No
D15	NOT USED			No
E14	BOOT_NORM*			No
D16	RS232_USB*			No
G12	UCTS1_USB_SPEED*			No
K11	UTXD1_USB_VPO			No
K14	USB_VMO			No
K13	USB_TX_EN			No
D5	8 KHZ_INT	SYNC	8 KHz Pulse	R406
H14	BL_EN	J601, pin 43		Yes
K4	LV_DETECT	D511, pin 1	3.0V	Yes
F9	NOT USED			No
J2	SC_FILT_EN	FL200, pin 7		No
A6	16_8MHZ	C726	16.8 MHz	Yes
J7	GATED_32_KHZ	U712, pin 4	32.768 KHz	Yes
G13	NOT USED			No
J1	MOD	R634	Bootstrap mode > 2.7V	Yes
A13	NOT USED			No
M6	NOT USED			No
R1	NOT USED			No
N3	NOT USED			No
M5	NOT USED			No
P2	NOT USED			No

Table 8.5-5. Patriot MCU/DSP (U800) Pinout (Continued)

U401 Pin Number	Description	To/From	Comment	Accessible on Main Board?
P1	NOT USED			No
N1	NOT USED			No
M4	NOT USED			No
M3	NOT USED			No
M2	NOT USED			No
M1	NOT USED			No
L4	NOT USED			No
L3	NOT USED			No
L1	NOT USED			No
L2	NOT USED			No
K2	NOT USED			No
T1	NOT USED			No
R2	NOT USED			No
T2	NOT USED			No
K7	NOT USED			No
N2	NOT USED			No
L5	NOT USED			No
L6	NOT USED			No
C4	NOT USED			No
L13	NOT USED			No
D11	NOT USED			No
E16	KVL_USB_DET*		Active Low	No
F15	16.8_MHZ_OUT	16out (TP)		No
K5	NOT USED			Yes
H8	NOT USED			No
F16	RESET	R808	Reset = 0V	Yes
K6	USB_VPI			No
H12	BL_FREQ			No
H13	NOT USED			No
E10	NOT USED			No
F10	NOT USED			No

Table 8.5-5. Patriot MCU/DSP (U800) Pinout (Continued)

U401 Pin Number	Description	To/From	Comment	Accessible on Main Board?
D12	TCK	TCK	ONCE/JTAG	Yes
C13	TMS	TMS	ONCE/JTAG	Yes
E11	TRST	TRST	ONCE/JTAG	Yes
A14	TDO	TDO	ONCE/JTAG	Yes
E12	TDI	TDI	ONCE/JTAG	Yes
M16	NOT USED			No
L14	NOT USED			No
P15	NOT USED			No
L11	NOT USED			No
M14	NOT USED			No
N16	NOT USED			No
L12	NOT USED			No
M12	CKO	CKO	Disabled	Yes
N15	NOT USED			No
M15	NOT USED			No
R12	ADDRESS 0	J601, pin 7		Yes
T13	ADDRESS 1			No
M10	ADDRESS 2			No
T12	ADDRESS 3			No
P13	ADDRESS 4			No
M9	ADDRESS 5			No
P10	ADDRESS 6			No
P12	ADDRESS 7			No
N9	ADDRESS 8			No
R10	ADDRESS 9			No
P9	ADDRESS 10			No
L10	ADDRESS 11			No
T10	ADDRESS 12			No
R9	ADDRESS 13			No
L9	ADDRESS 14			No
K9	ADDRESS 15			No

Table 8.5-5. Patriot MCU/DSP (U800) Pinout (Continued)

U401 Pin Number	Description	To/From	Comment	Accessible on Main Board?
J9	ADDRESS 16			No
L8	ADDRESS 17			No
M8	ADDRESS 18			No
N8	ADDRESS 19			No
K8	ADDRESS 20			No
L7	ADDRESS 21			No
T7	ADDRESS 22			No
R7	ADDRESS 23	R814		Yes
R3	DATA 15			No
T3	DATA 14			No
N4	DATA 13			No
P4	DATA 12			No
R4	DATA 11			No
J8	DATA 10			No
T4	DATA 9			No
N5	DATA 8			No
P5	DATA 7	R644		Yes
R5	DATA 6	R643		Yes
T5	DATA 5	R642		Yes
R6	DATA 4	R641		Yes
T6	DATA 3	R640		Yes
M7	DATA 2	R639		Yes
N7	DATA 1	R638		Yes
P7	DATA 0	R637		Yes
N11	R_W			No
T11	NOT USED			No
R14	NOT USED			No
N12	CS3*			No
T14	CS2			No
R11	NOT USED			No
R15	CS0	TP_CS0	Active Low	Yes

Table 8.5-5. Patriot MCU/DSP (U800) Pinout (Continued)

U401 Pin Number	Description	To/From	Comment	Accessible on Main Board?
P16	OE_EN			No
M13	EB1_N			No
R13	EBO_N			No
N14	NOT USED			No
T16	WAIT			No
P14	NOT USED			No
N13	ADV			No
T15	B_CLK			No

Table 8.5-6. MAKO (U701) Pinout

Pin Ref Number	U701 Pin Name	To/From	Comment	Accessible on Main Board?
A4	VREF	GND	1.231	Yes
N3	UCM_SS	UCM_SS	2.9	No
P9	ONE_WIRE_1	ONE_WIRE_OPT	2.9	Yes
A5	BBP_CLK	TX_SSI_CLK	1.536MHz	Yes
H4	VCM2	GND	1/2 B+ (3.75V)	Yes
J1	EXT_MIC_M	GND	3.3V	Yes
J2	EXT_MIC_P	EXT_MIC	3.3V	Yes
J3	VCM1	GND	3.3V	Yes
K1	INT_MIC_M	GND	3.3V	Yes
K2	INT_MIC_P	INT_MIC	3.3V	Yes
B5	BBP_SYNC	TX_SSI_FSYNC	48KHz	Yes
E7	VC_DCLK	CODEC_DCLK	520Hz	Yes
L10	VMES	GND	5V	Yes
L11	ATOD_2	EMERG	5V	Yes
L2	MIC_BIAS	EXT_MIC	5V	Yes
L6	USB_CONNECT	Q704	5V	Yes
L8	ONE_WIRE_BATT	BAT_STATUS	5V	Yes
M10	TXDO_BDI_5V	RS232_DO_USB+	5V	Yes

Table 8.5-6. MAKO (U701) Pinout (Continued)

Pin Ref Number	U701 Pin Name	To/From	Comment	Accessible on Main Board?
M11	RTS_FILLSEN_5V	RTS	5V	Yes
M12	ADC_VREF	GND	5V	Yes
M13	ATOD_1	VOLUME	5V	Yes
N12	RXDIN_5V	RS232_DI_USB-	5V	Yes
N13	SB96_BUS_BUSY	SB9600_BUSY	5V	Yes
N6	USB1_DP	RS232_DI_USB-	5V	Yes
N9	SB96_BDO_KF_5V	LHDATA_KEYFAIL	5V	Yes
P13	CTS_CABLE_DET_5V	CTS	5V	Yes
P7	USB1_DM	RS232_DI_USB+	5V	Yes
D7	VC_FSYNC	CODEC_FSYNC	8KHz	Yes
F1	INT_SPKR_P	INT_SPKR_POS	B+(7.5V)	Yes
F2	INT_SPKR_M	INT_SPKR_NEG	B+(7.5V)	Yes
G1	EXT_SPKR_M	EXT_SPKR_NEG	B+(7.5V)	Yes
G2	PA_IN_P	VC_OUT_P	B+(7.5V)	Yes
G3	PA_IN_M	VC_OUT_N	B+(7.5V)	Yes
H1	EXT_SPKR_P	EXT_SPKR_POS	B+(7.5V)	Yes
H2	VC_OUT_M	PA_IN_N	B+(7.5V)	Yes
H3	VC_OUT_P	PA_IN_P	B+(7.5V)	Yes
A3	TEST	GND	GND	No
C4	SCAN_EN	GND	GND	No
E8	VFUSE	GND	GND	No
B11	AD_TRIG	ADTRIG	NA	No
B6	SPI_DI	SPI_MOSIB	NA	No
C6	SPI_DO	SPI_MISOB	NA	No
A11	TX_RX	NC	NC	No
B12	OPTION_INTX	NC	NC	No
B7	VC_TX	NC	NC	No
C10	USB_INTX	NC	NC	No
C11	OPT_GPIO1	NC	NC	No
D11	OPT_GPIO3	NC	NC	No

Table 8.5-6. MAKO (U701) Pinout (Continued)

Pin Ref Number	U701 Pin Name	To/From	Comment	Accessible on Main Board?
F10	OPT_GPIO0	NC	NC	No
G10	OPT_GPIO2	NC	NC	No
J5	TXDO_BDI_UP_3V	NC	NC	No
K12	ATOD_7	NC	NC	No
K13	ATOD_8	NC	NC	No
K6	TXDO_BDI_ENC_3V	NC	NC	No
K7	OPTA_SEL1	NC	NC	No
K8	OPTB_SEL1	NC	NC	No
L3	FE_TUNE1	NC	NC	No
M14	ATOD_3	NC	NC	No
M2	FE_TUNE2	NC	NC	No
M3	RTS_FILLSEN_3V	NC	NC	No
M8	ONE_WIRE_2	NC	NC	No
M9	OPTA_SEL2	NC	NC	No
N1	PWR_CTRL	NC	NC	No
N10	OPTA_SEL3	NC	NC	No
N11	OPTB_SEL3	NC	NC	No
N2	RXDIN_ENC_3V	NC	NC	No
N7	USB2_DP	NC	NC	No
N8	SB96D_BDO_KF_3V	NC	NC	No
P10	OPTA_SEL0	NC	NC	No
P11	OPTB_SEL0	NC	NC	No
P12	OPTB_SEL2	NC	NC	No
P2	RXDIN_3V	NC	NC	No
P8	USB2_DN	NC	NC	No
E1	PA_BPLUS	SW_B+	SW_B+(7.5V)	Yes
E3	BPLUS	BPLUS	UNSW_B+(7.5V)	No
A7	VC_RX	CODEC_RX	V1.55(1.6V)	Yes
A6	LOGIC_VDD	V2.9	V2.9	No
A8	RS232_USB_X	RS232_USB_X	V2.9	Yes

Table 8.5-6. MAKO (U701) Pinout (Continued)

Pin Ref Number	U701 Pin Name	To/From	Comment	Accessible on Main Board?
K11	ATOD_6	V2.9	V2.9	Yes
L13	ATOD_5	V2.9	V2.9	Yes
L5	APCO	V2.9	V2.9	Yes
M4	VC_TX3V	CODEC_TX	V2.9	Yes
N14	ATOD_0	V2.9	V2.9	No
L12	ATOD_4	BAT_STATUS	VCC5(5V)	Yes
A10	UART2_RXD_OD	SB96D_BDO_KF_3V/ V2.9/URXD3	VDD(1.65-3.6V)	Yes
A9	USB2_OE_RCV_RTS	URTS1_XRXD	VDD(1.65-3.6V)	Yes
B10	CTS_X	UCTS_USB_SPEED	VDD(1.65-3.6V)	Yes
B8	USB1_OE	USB_TXENAB	VDD(1.65-3.6V)	Yes
B9	USB2_DAT_VP	USB_VPI	VDD(1.65-3.6V)	Yes
C12	BUSY_IN	URTS2	VDD(1.65-3.6V)	Yes
C7	BOOT_NORM_X	BOOT_NORM_X	VDD(1.65-3.6V)	Yes
C8	USB1_DAT_TXD	TXD1_USB_VPO	VDD(1.65-3.6V)	Yes
C9	USB2_SE0_VM_RXD	URXD1_USB_VMI	VDD(1.65-3.6V)	Yes
D10	CABLE_DET_3V	KVL_USB_DET	VDD(1.65-3.6V)	Yes
D6	SPI_CS	MAKO_CE	VDD(1.65-3.6V)	Yes
D8	USB1_SE0	USB_VMO	VDD(1.65-3.6V)	Yes
E11	BUSY_OUT	UCTS2	VDD(1.65-3.6V)	Yes
E6	SPI_CLK	SCKB	VDD(1.65-3.6V)	Yes
E9	UART2_TXD	UTXD2	VDD(1.65-3.6V)	Yes
L7	ONE_WIRE_UP	ONE_WIRE_UP/V2.9	VDD(1.65-3.6V)	Yes
	POWER MANAGE- MENT BLOCK			
B2	BAT_TYPE	GND	0-5V	Yes
D2	BAT_3V6	GND	0-5V	Yes
D3	REG_3V6	GND	0-5V	Yes
G4	HV_BG	GND	1.2V	Yes
M1	TXCO_IN	16_8MHz	16.8MHz (2.5-3.3V)	Yes
J13	SW2_VOUT	GND	2.3V	Yes

Table 8.5-6. MAKO (U701) Pinout (Continued)

Pin Ref Number	U701 Pin Name	To/From	Comment	Accessible on Main Board?
J14	SW2_LX	GND	2.3V	Yes
A2	PGLD03	VSAVE	2.5V	Yes
C2	VSAVE	VSAVE	2.5V	Yes
E4	MECH_SW	SW_B+	2.5V	Yes
N5	V04_O	GND	2.775V	Yes
P6	V07_O	GND	2.8V	Yes
A12	XOUT	XTAL FREQ	24.576MHz (3.3V)	Yes
A13	XIN	XTAL FREQ	24.576MHz (3.3V)	Yes
L1	V09_O	GND	3.3V	Yes
M6	V10_O	GND	3.3V	Yes
B1	XTAL32_OUT	32.768KHz	32.768MHz (2.5-3.3V)	Yes
C1	XTAL32_IN	32.768KHz	32.768MHz (2.5-3.3V)	Yes
F5	GATED_32K_CLK	MAKO_32KHZ	32KHZ(VDD)	Yes
K4	V08_O	VCC5 SUPPLY	5V	Yes
E2	FET_ENX	VPP_EN/UNSW_B+/ SW_B+	B+(7.5V)	Yes
F14	SW1_PHASE	VSW1	B+(7.5V)	Yes
F3	BAT_RTC	GND	B+(7.5V)	Yes
B3	SW_TYPE	GND	GND	No
C3	PGLD02	GND	GND	No
D14	GND7	GND	GND	No
D4	TCXO_SEL_16_24	GND	GND	No
D9	GND9	GND	GND	No
G5	GND4	GND	GND	No
H14	SW1_GND	Q502	GND	No
H5	GND8	GND	GND	No
J4	GND3	GND	GND	No
K9	GND5	GND	GND	No
L14	SW2_GND	GND	GND	No
L4	GND6	GND	GND	No
L9	V10_GND	GND	GND	No

Table 8.5-6. MAKO (U701) Pinout (Continued)

Pin Ref Number	U701 Pin Name	To/From	Comment	Accessible on Main Board?
M7	GND2	GND	GND	No
P5	GND1	GND	GND	No
B13	VBUS_SUPPLY	NC	NC	No
B4	IGN_X	NC	NC	No
C13	VBUS2_CMD	NC	NC	No
C14	VBUS1_CMD	NC	NC	No
D12	VBUS2	NC	NC	No
D13	SW5_VDD	NC	NC	No
E12	VBUS1_SENS	NC	NC	No
E13	SW5_SUMCOMP	NC	NC	No
E14	SW5_VSENSE	NC	NC	No
F11	VBUS2_SENS	NC	NC	No
F12	SW5_VOUT	NC	NC	No
F13	SW5_VDDHV	NC	NC	No
F4	EMERG_PB	NC	NC	No
G11	SW5_PHASE	NC	NC	No
H10	VBUS1	NC	NC	No
H13	SW1_DH	NC	NC	No
J11	SW1_VSEN_BST	NC	NC	No
NC1	NC1	NC	NC	No
NC2	NC2	NC	NC	No
NC3	NC3	NC	NC	No
NC4	NC4	NC	NC	No
NC5	NC5	NC	NC	No
NC6	NC6	NC	NC	No
G12	SW1_VDDHV	SW_B+	SW_B+(7.5V)	Yes
H11	SW1_VSEN_BUK	SW_B+	SW_B+(7.5V)	Yes
K3	V08_I	SW_B+	SW_B+(7.5V)	Yes
D1	BAT_7V5	UNSW_B+	UNSW_B+(7.5V)	Yes
P4	V03_O	V1.55	V1.55(1.6V)	Yes

Table 8.5-6. MAKO (U701) Pinout (Continued)

Pin Ref Number	U701 Pin Name	To/From	Comment	Accessible on Main Board?
N4	V02_O	V1.875	V1.875	Yes
P3	V06_O	V2.9	V2.9	Yes
C5	RESETX	MAKO RESET	VDD(1.65-3.6V)	Yes
D5	INT_X	MAKO_INT_X	VDD(1.65-3.6V)	Yes
G13	SW1_VDD	Q702	VDD(1.65-3.6V)	Yes
G14	SW1_SUMCOMP_DL	Q702	VSW1 (3.6V)	Yes
H12	SW1_VOUT	VSW1	VSW1 (3.6V)	No
J10	V10_I	VSW1	VSW1 (3.6V)	Yes
J12	SW2_VCC	VSW1	VSW1 (3.6V)	Yes
K14	SW2_VCCS	VSW1	VSW1 (3.6V)	Yes

Chapter 9.1 VHF Schematics, Board Overlays, and Parts Lists

9.1.1 Introduction

This chapter contains the schematics, board layouts, and parts lists for the XTS 2500/2500I/2250/1500 radios. Use them in conjunction with the theory of operation and the troubleshooting procedures, charts, and waveforms to isolate a problem to the component level.

Table 9.1-1. VHF Schematics, Board Overlays and Parts Lists

Schematic/Board Layout	Page No.
Radio Interconnect Block Diagram	9.1-2
PMLD4303A/ PMLD4303D Top Level Schematic	9.1-3
PMLD4303A/ PMLD4303D Controller Interface Schematic	9.1-4
PMLD4303A/ PMLD4303D Interface and Accessories Schematic	9.1-5
PMLD4303A/ PMLD4303D Side Connector Schematic	9.1-6
PMLD4303A/ PMLD4303D Controller Schematic	9.1-7
PMLD4303A/ PMLD4303D Patriot Bravo (U800) Schematic	9.1-8
PMLD4303A/ PMLD4303D MAKO DC and Audio Schematic - Sheet 1 of 2	9.1-9
PMLD4303A/ PMLD4303D MAKO DC and Audio Schematic - Sheet 2 of 2	9.1-10
PMLD4303A/ PMLD4303D Memory Schematic	9.1-11
PMLD4303A/ PMLD4303D Frequency Generation Unit (FGU) and Digital to Analog Converter (DAC) Schematic	9.1-12
PMLD4303A Frequency Generation Unit (FGU) Schematic - Sheet 1 of 3	9.1-13
PMLD4303D Frequency Generation Unit (FGU) Schematic - Sheet 1 of 3	9.1-14
PMLD4303A/ PMLD4303D Frequency Generation Unit (FGU) Schematic - Sheet 2 of 3	9.1-15
PMLD4303A/ PMLD4303D Frequency Generation Unit (FGU) Schematic - Sheet 3 of 3	9.1-16
PMLD4303A/ PMLD4303D Receiver Front End and DC Schematic	9.1-17
PMLD4303A/ PMLD4303D Receiver Front End Schematic	9.1-18
PMLD4303A/ PMLD4303D Receiver Schematic - Sheet 1 of 4	9.1-19
PMLD4303A/ PMLD4303D Receiver Schematic - Sheet 2 of 4	9.1-20
PMLD4303A/ PMLD4303D Receiver Schematic - Sheet 3 of 4	9.1-21
PMLD4303A/ PMLD4303D Receiver Schematic (Regulators) - Sheet 4 of 4	9.1-22
PMLD4303A/ PMLD4303D RF Schematic	9.1-23
PMLD4303A/ PMLD4303D Transmitter Schematic	9.1-24
PMLD4303A RF Controls Schematic	9.1-25
PMLD4303D RF Controls Schematic	9.1-26
PMLD4303A/ PMLD4303D Main Circuit Board Component Location Detail - Side 1	9.1-27
PMLD4303A/ PMLD4303D Main Circuit Board Component Location Detail - Side 2	9.1-28
PMLD4303A/ PMLD4303D Main Circuit Board Electrical Parts List	9.1-29

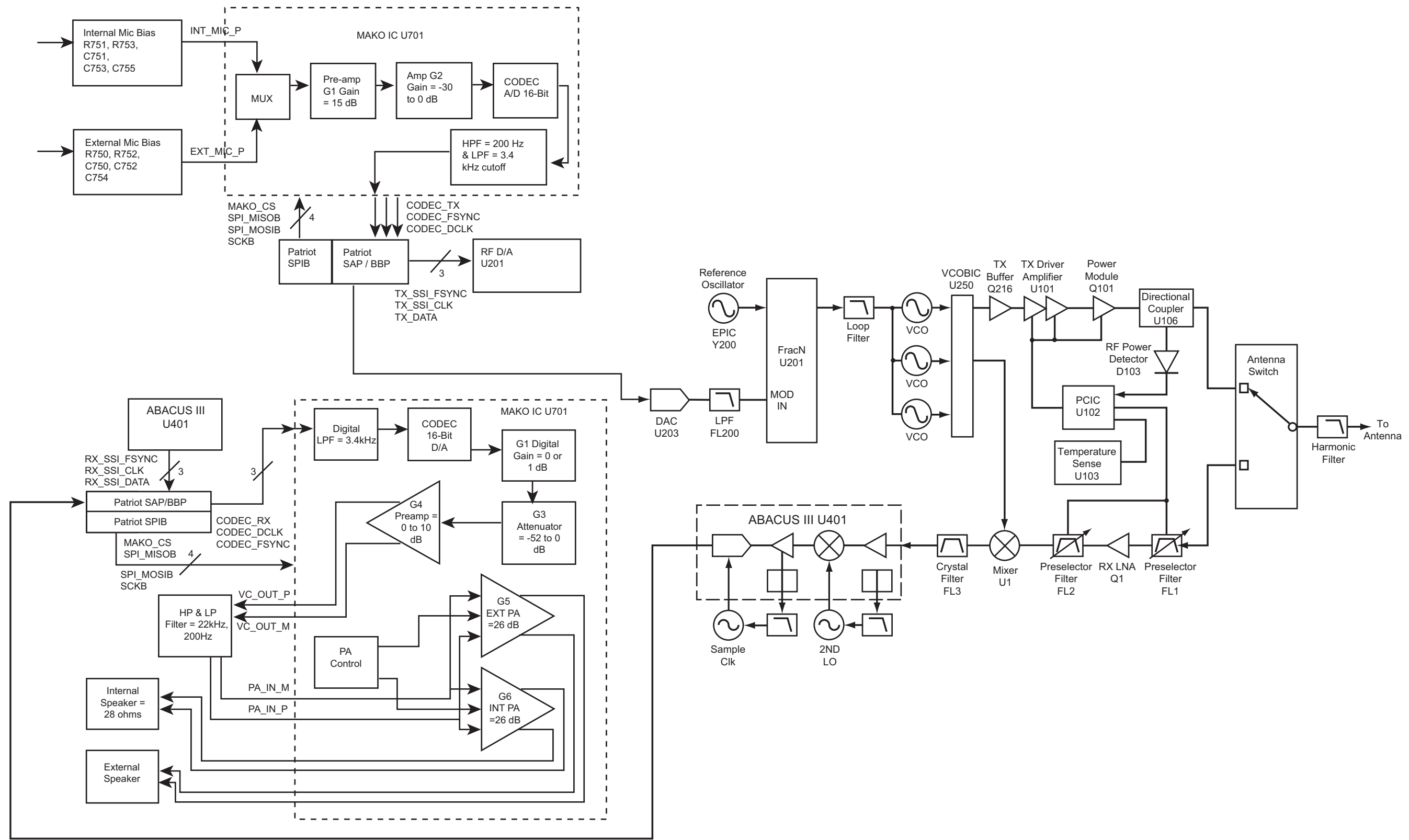

MAEPF-27352-O

Figure 9.1-1. Radio Interconnect Block Diagram

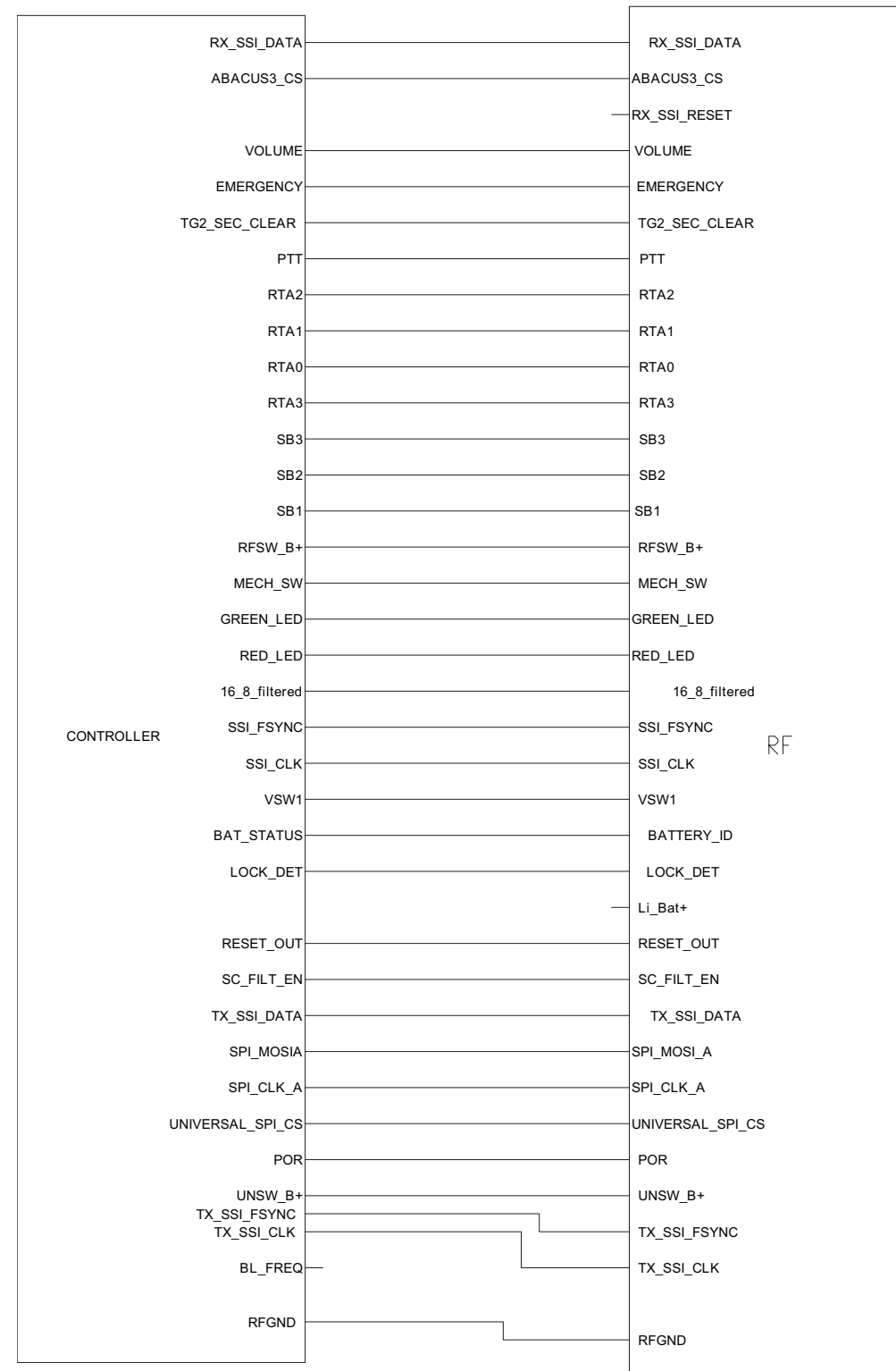

Figure 9.1-2. PMLD4303A/ PMLD4303D Top Level Schematic

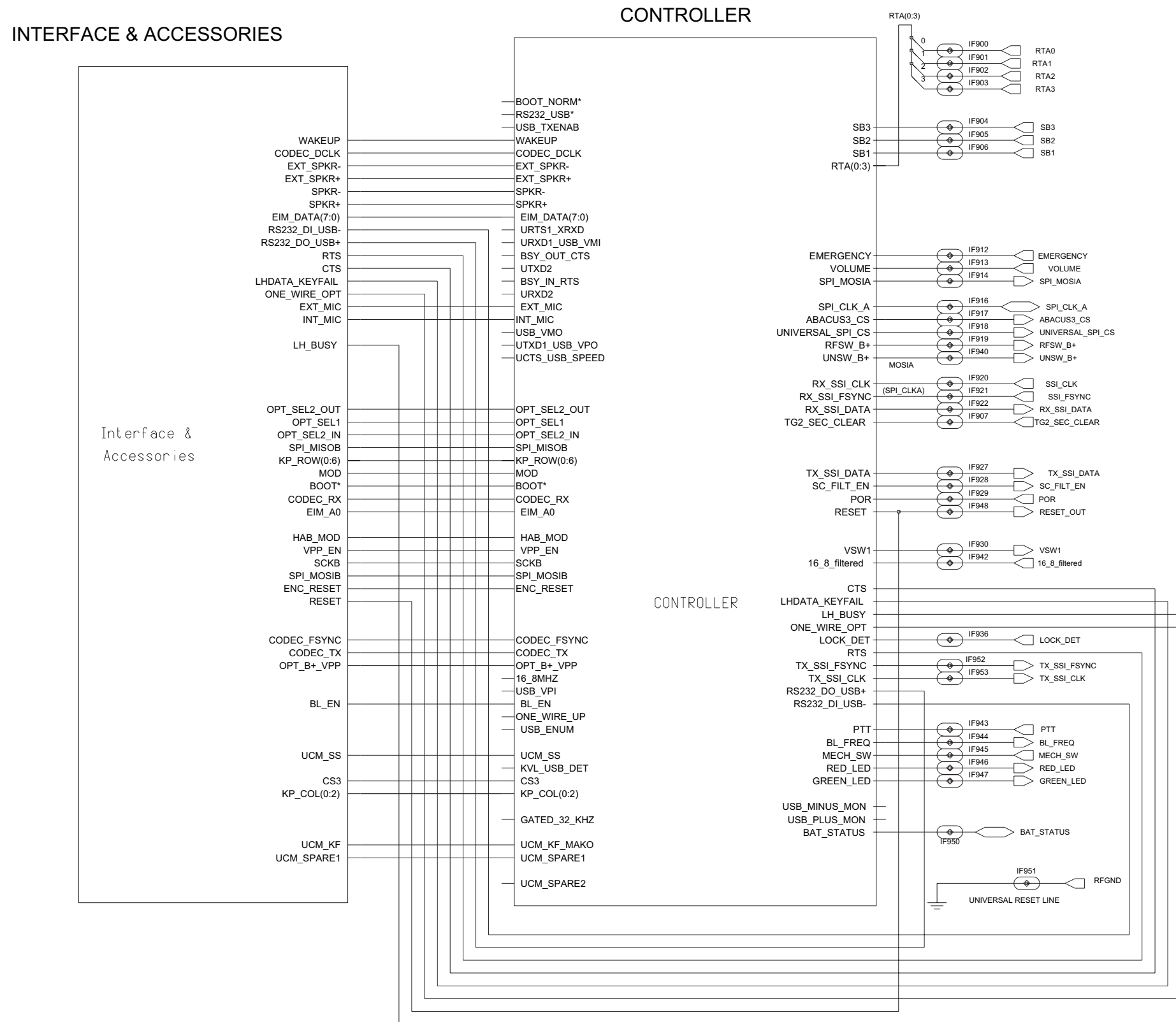

Figure 9.1-3. PMLD4303A/ PMLD4303D Controller Interface Schematic

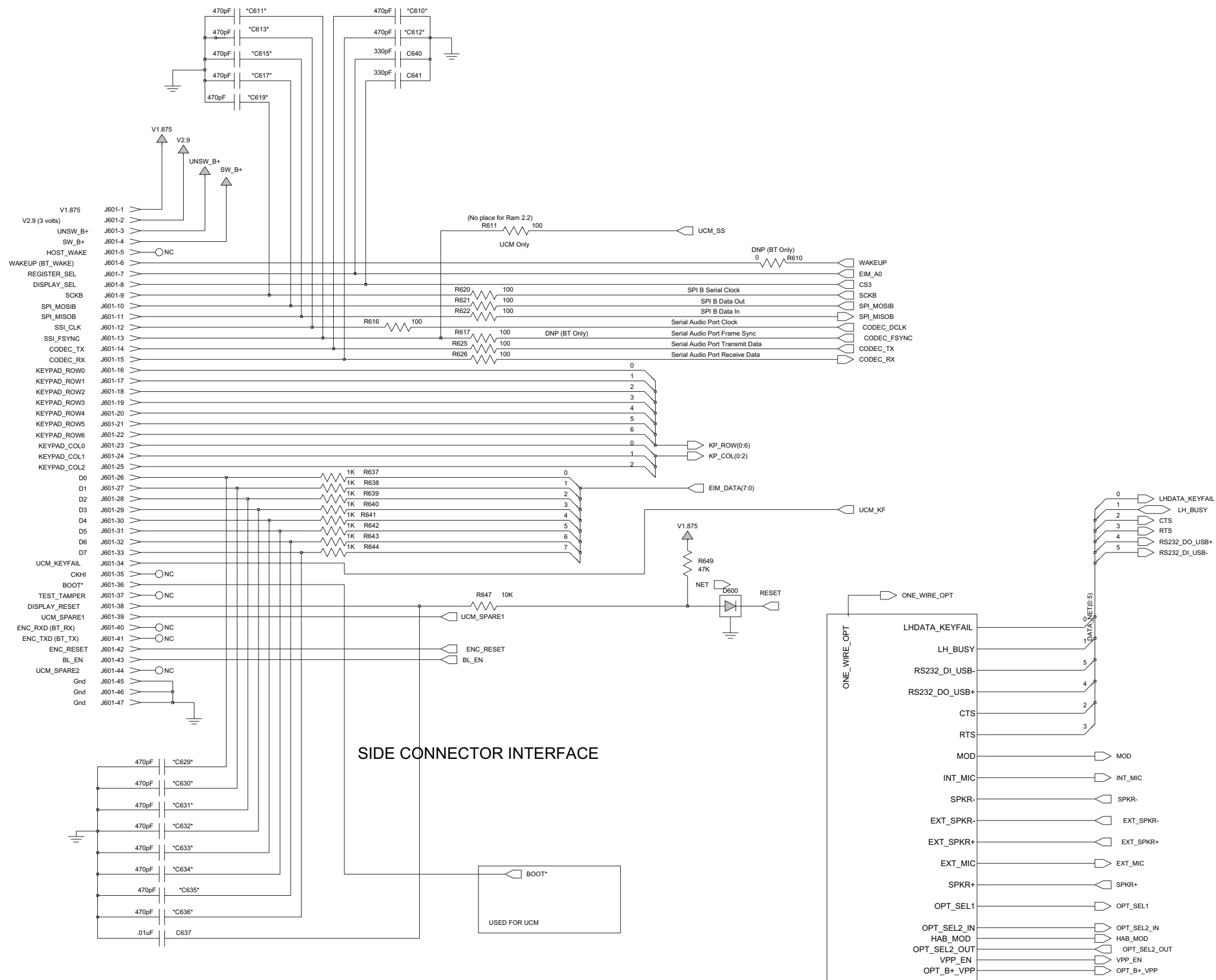

Figure 9.1-4. PMLD4303A/ PMLD4303D Interface and Accessories Schematic

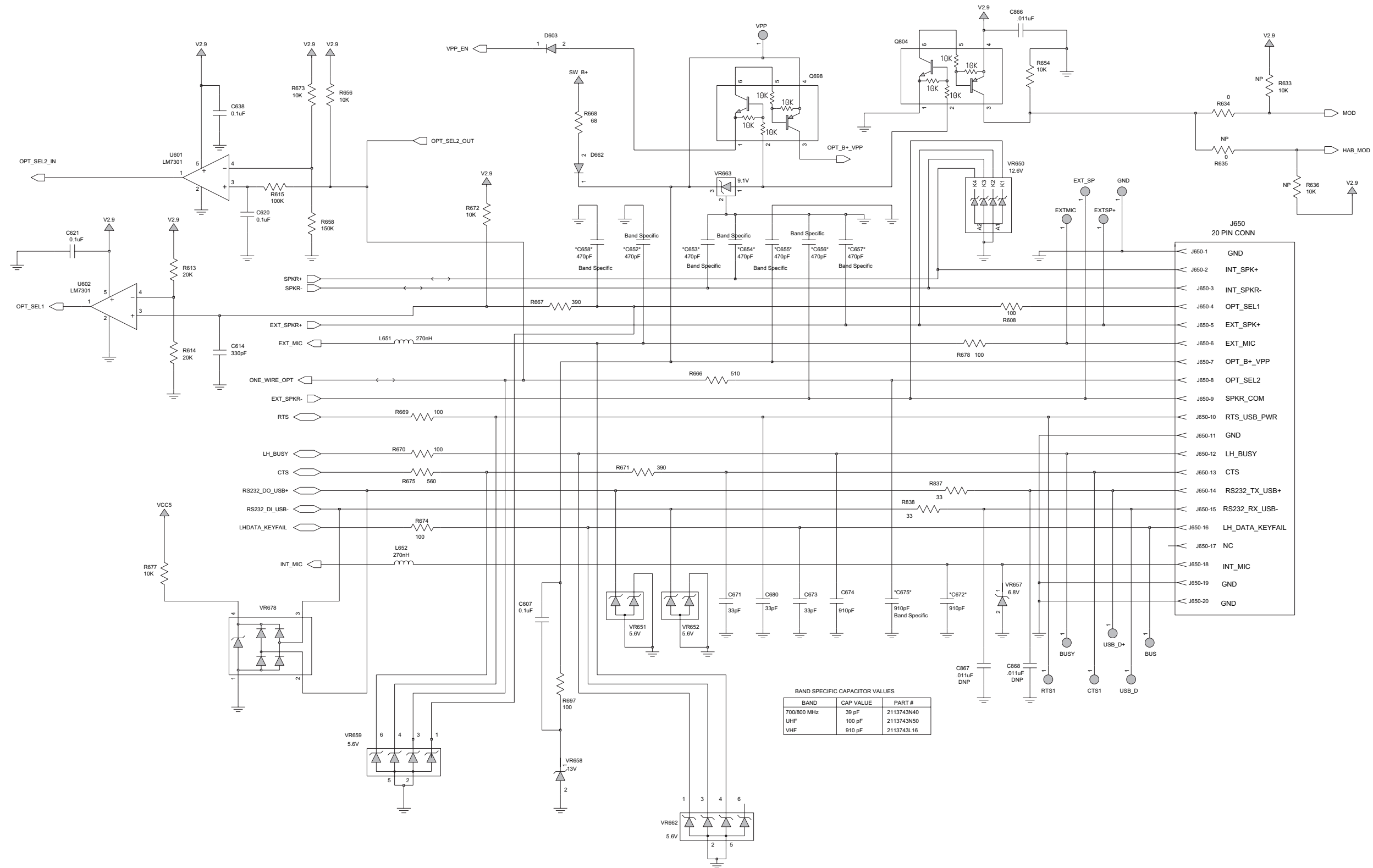

Figure 9.1-5. PMLD4303A/ PMLD4303D Side Connector Schematic

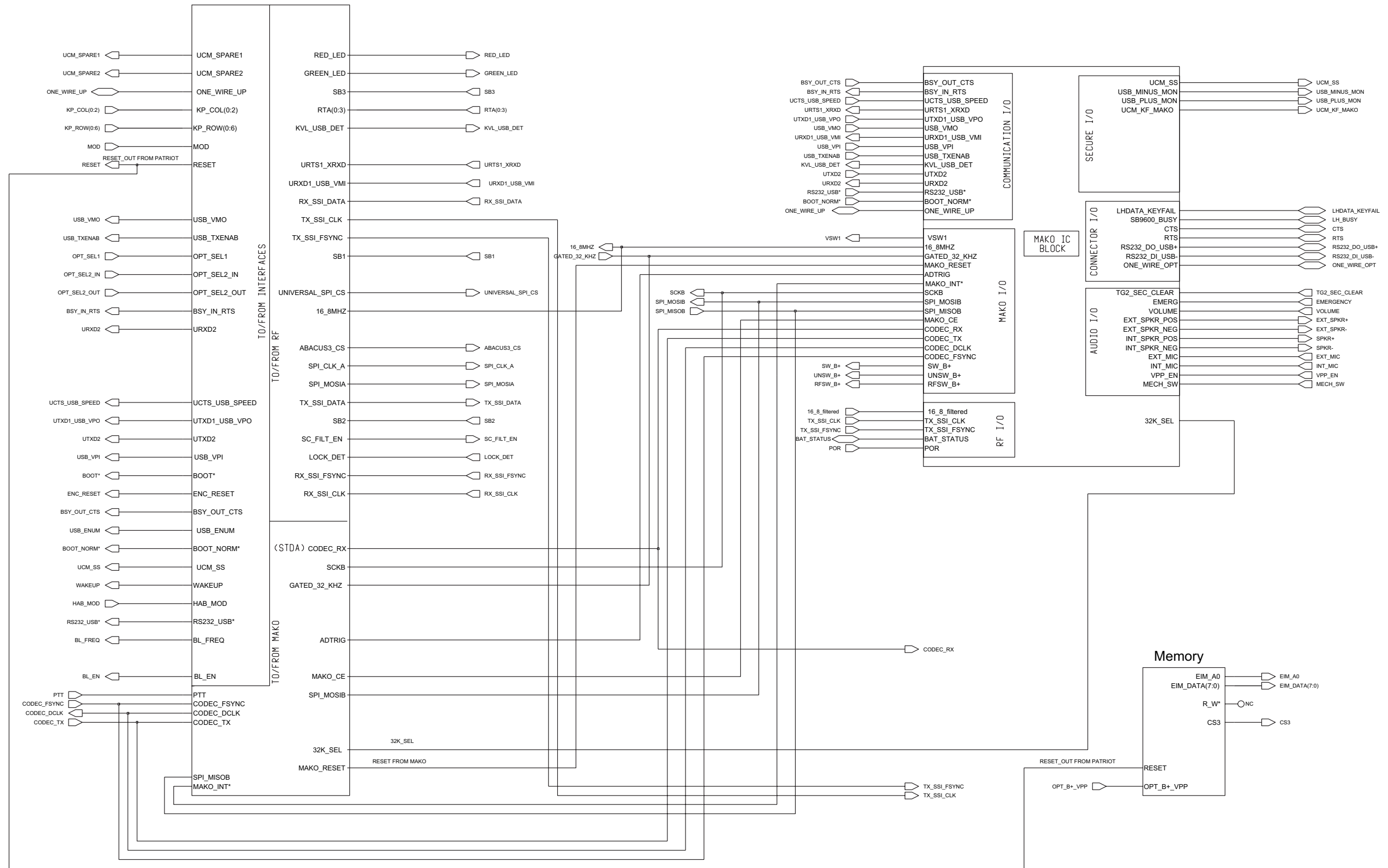

Figure 9.1-6. PMLD4303A/ PMLD4303D Controller Schematic

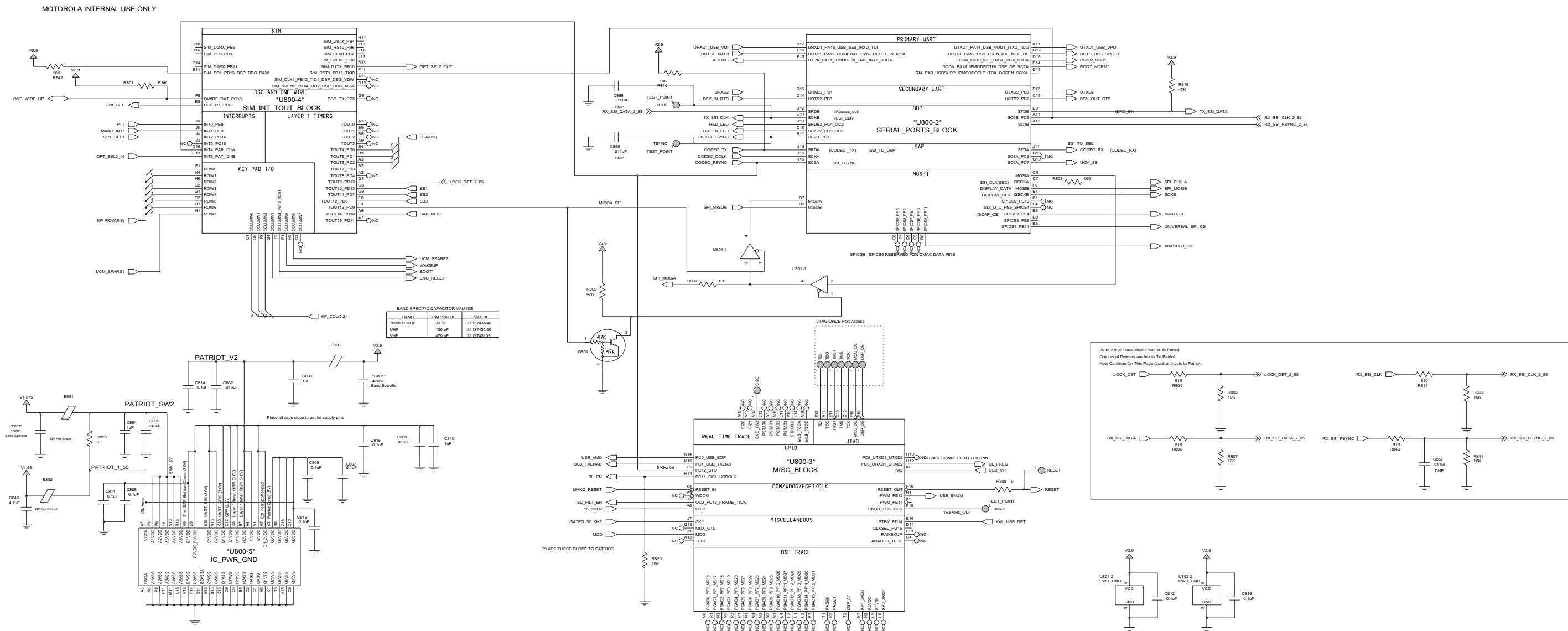

Figure 9.1-7. PMLD4303A/PMLD4303D Patriot Bravo (U800) Schematic

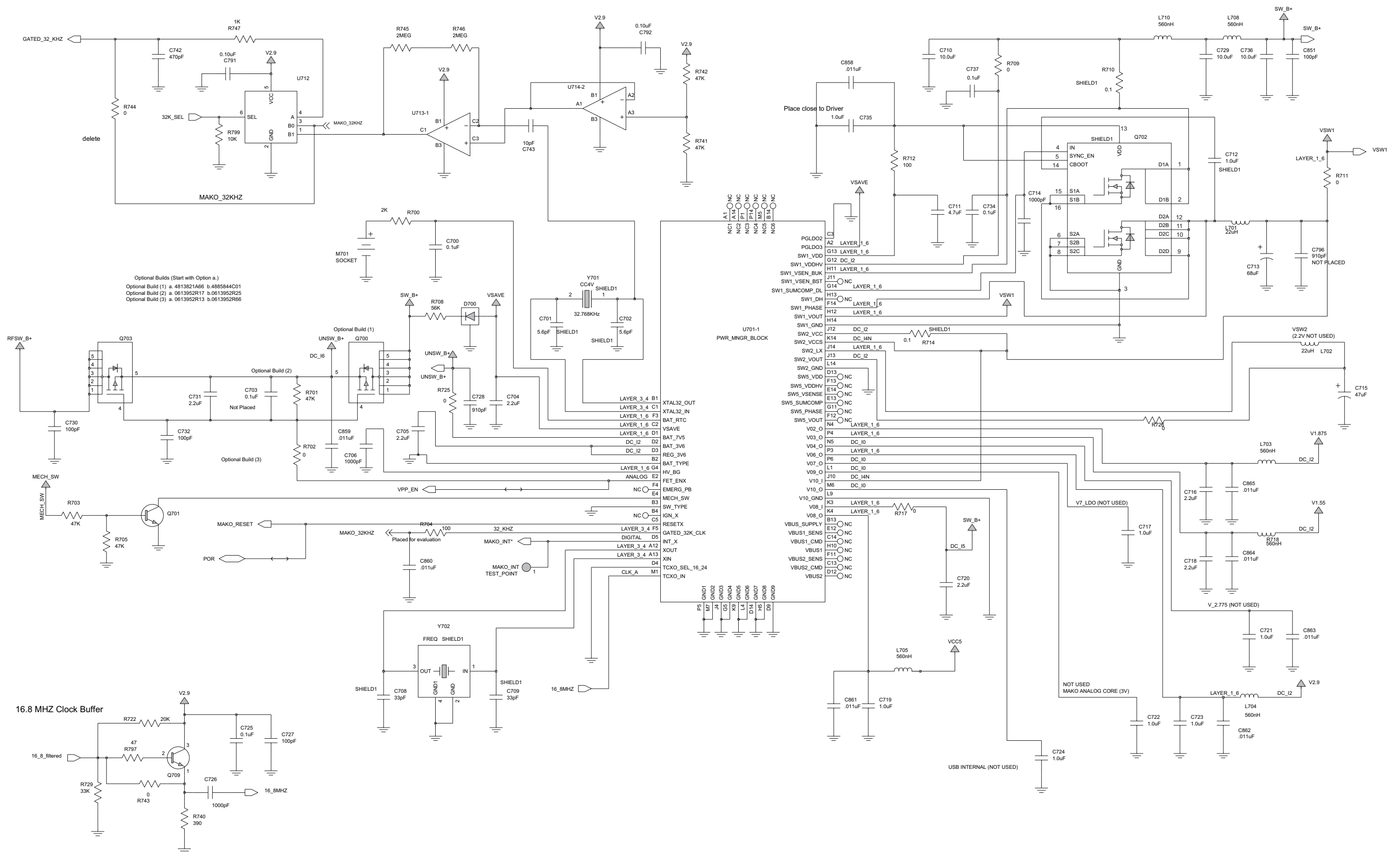

Figure 9.1-8. PMLD4303A/ PMLD4303D MAKO DC and Audio Schematic - Sheet 1 of 2

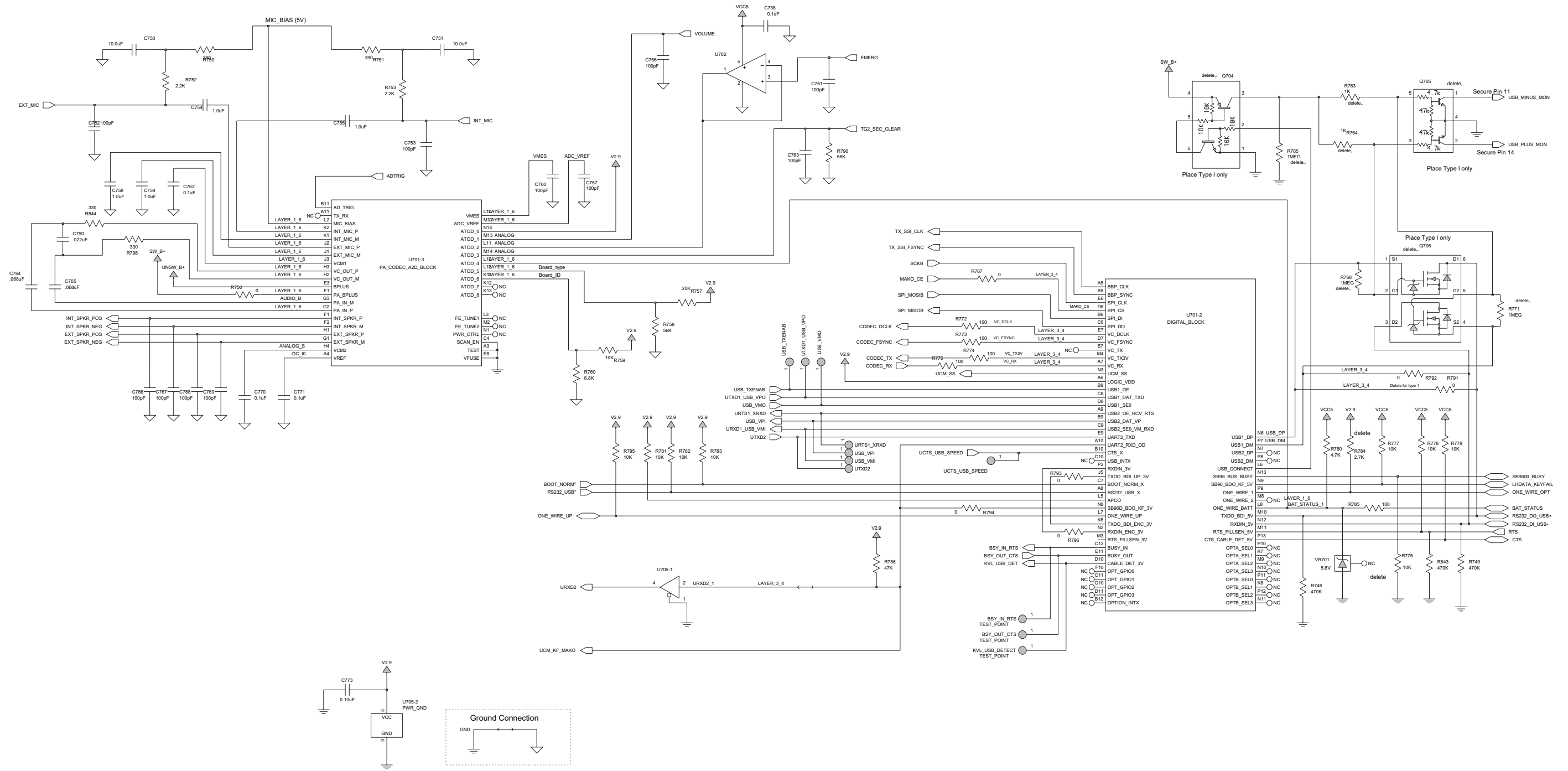

Figure 9.1-9. PMLD4303A/ PMLD4303D MAKO DC and Audio Schematic - Sheet 2 of 2

MOTOROLA CONFIDENTIAL PROPRIETARY

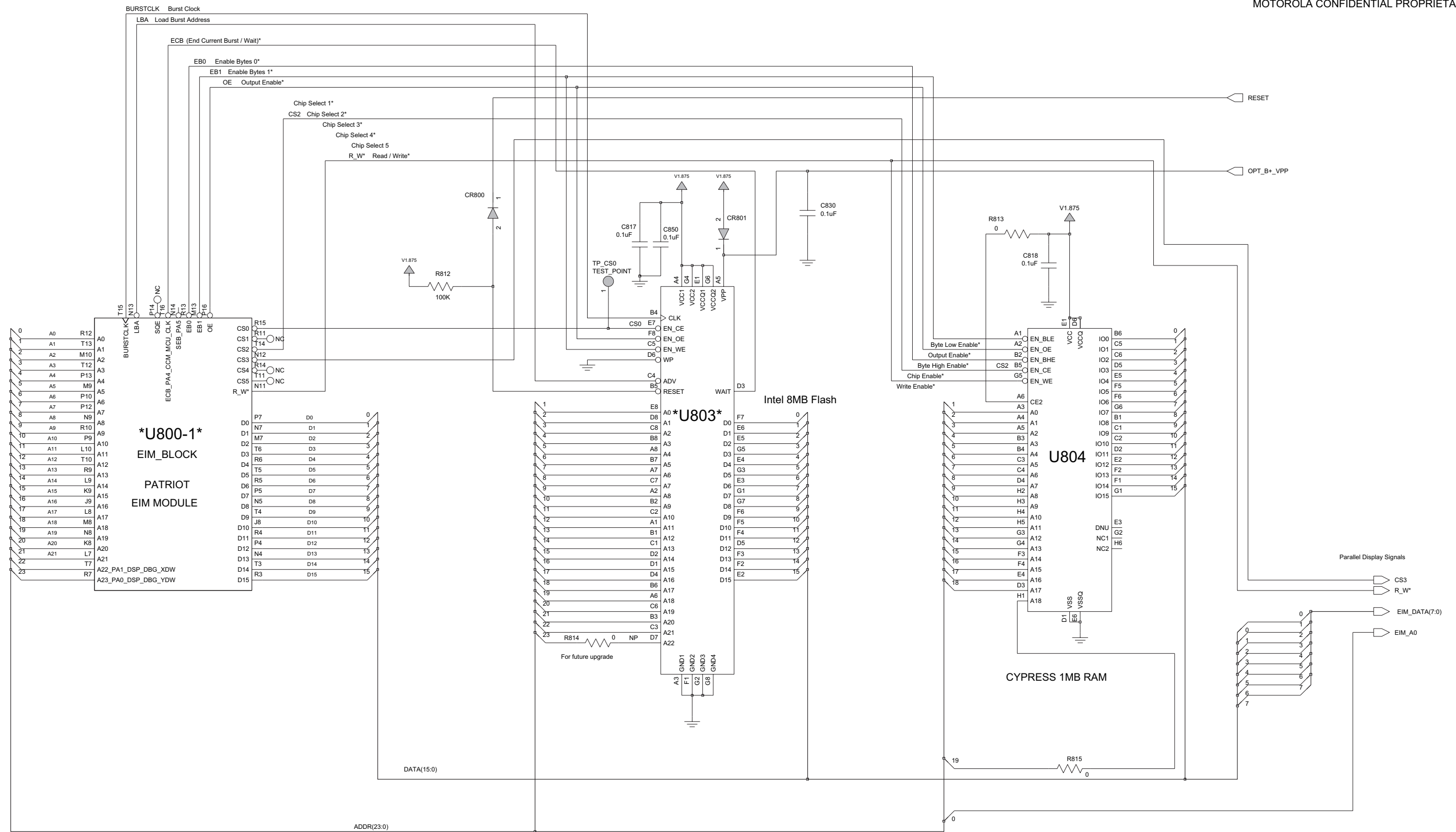

Figure 9.1-10. PMLD4303A/ PMLD4303D Memory Schematic

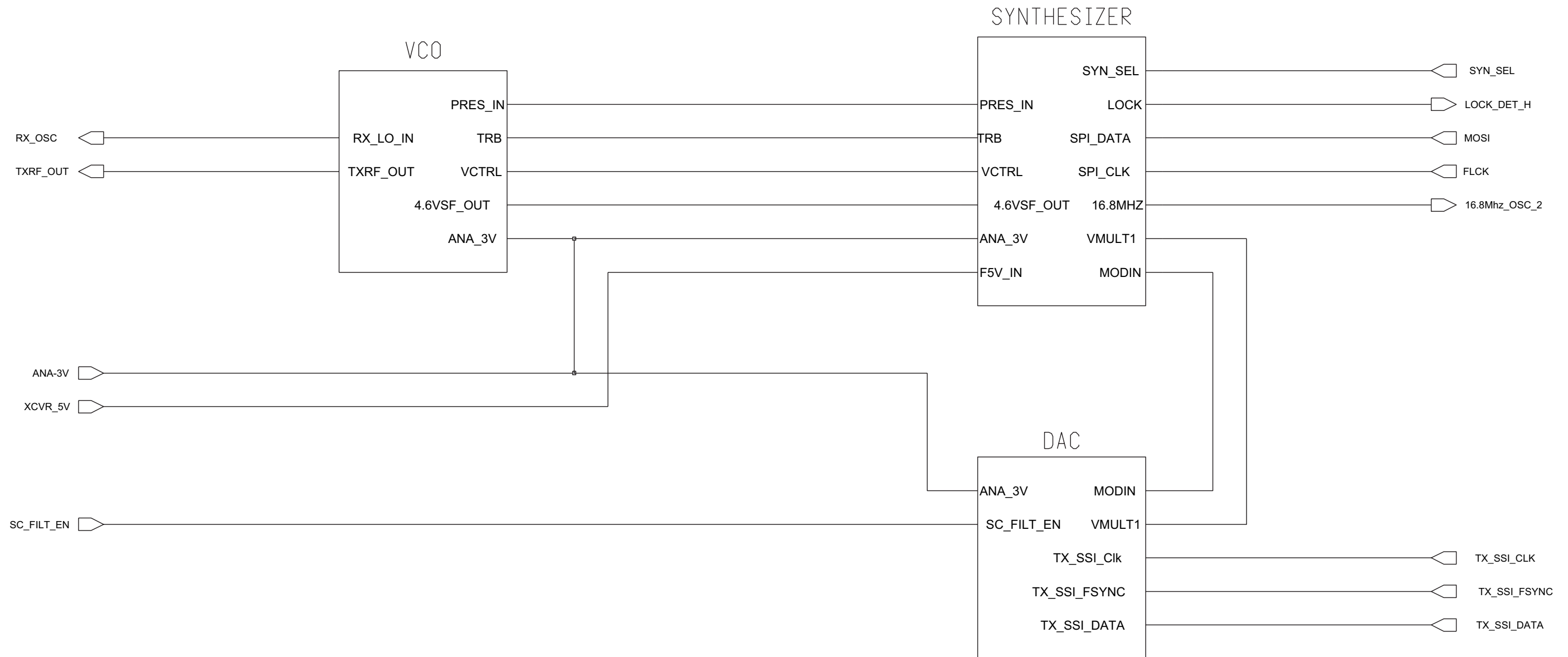

Figure 9.1-11. PMLD4303A/ PMLD4303D Frequency Generation Unit (FGU) and Digital to Analog Converter (DAC) Schematic

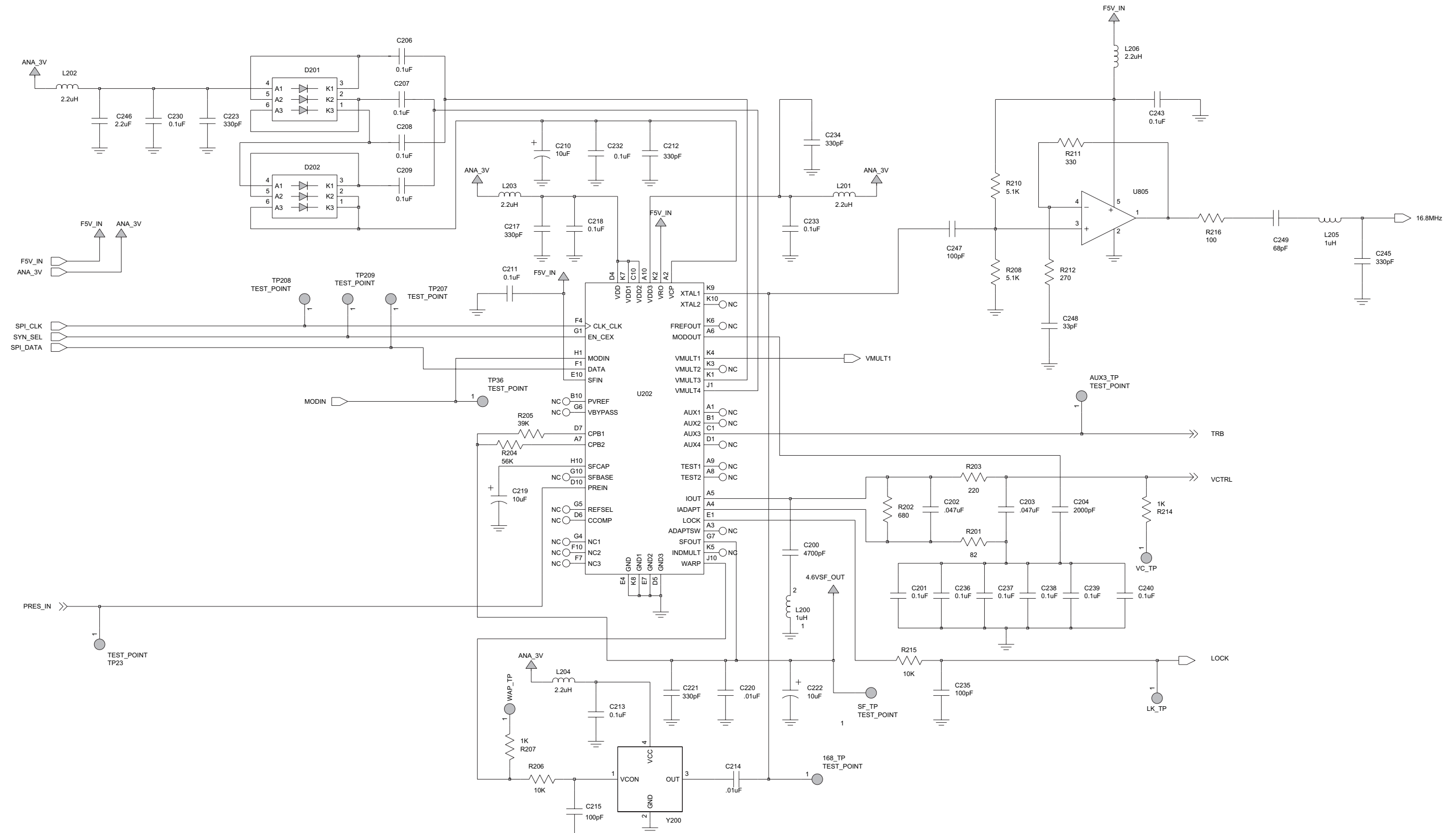

Figure 9.1-12. PMLD4303A Frequency Generation Unit (FGU) Schematic - Sheet 1 of 3

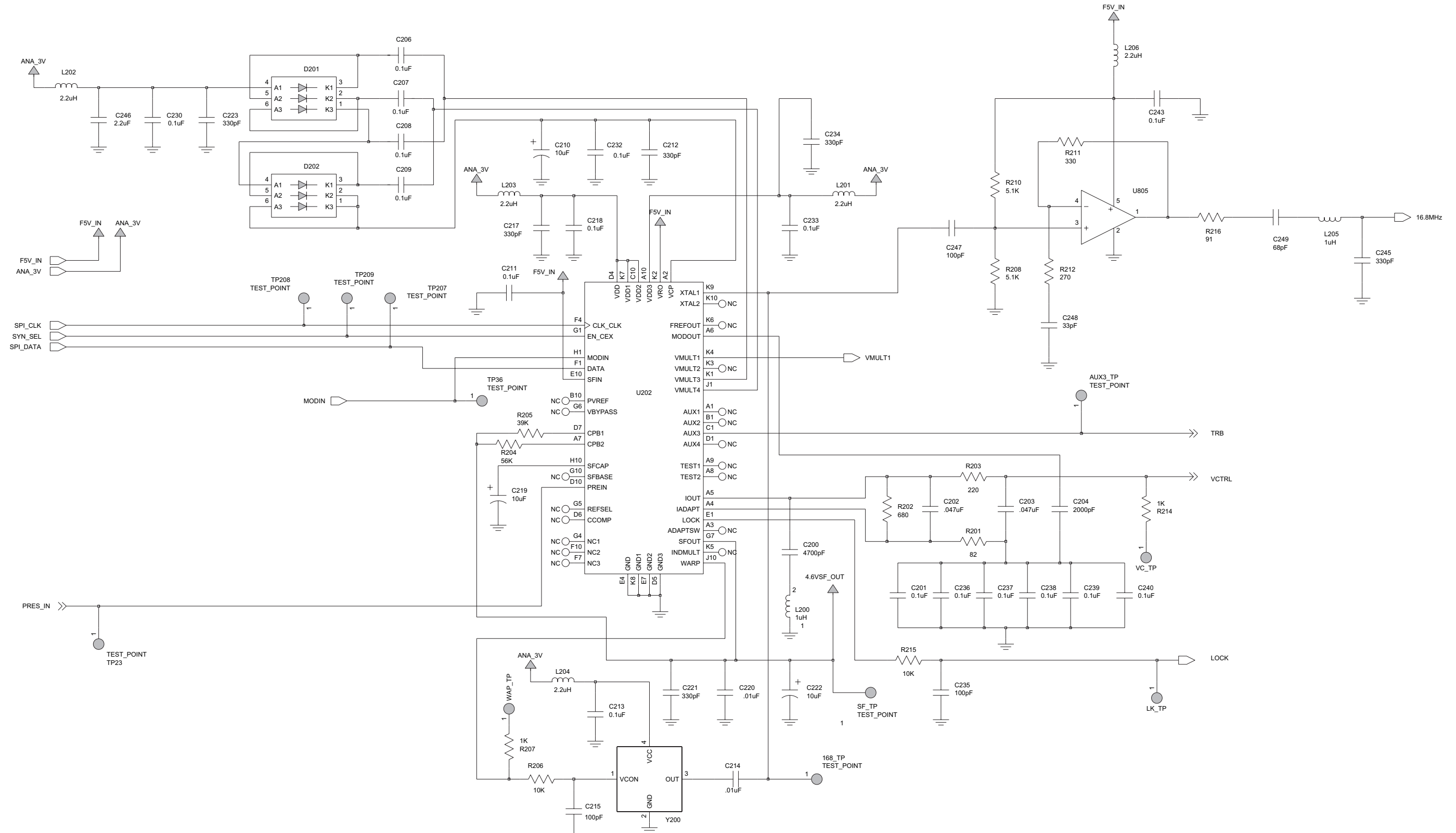
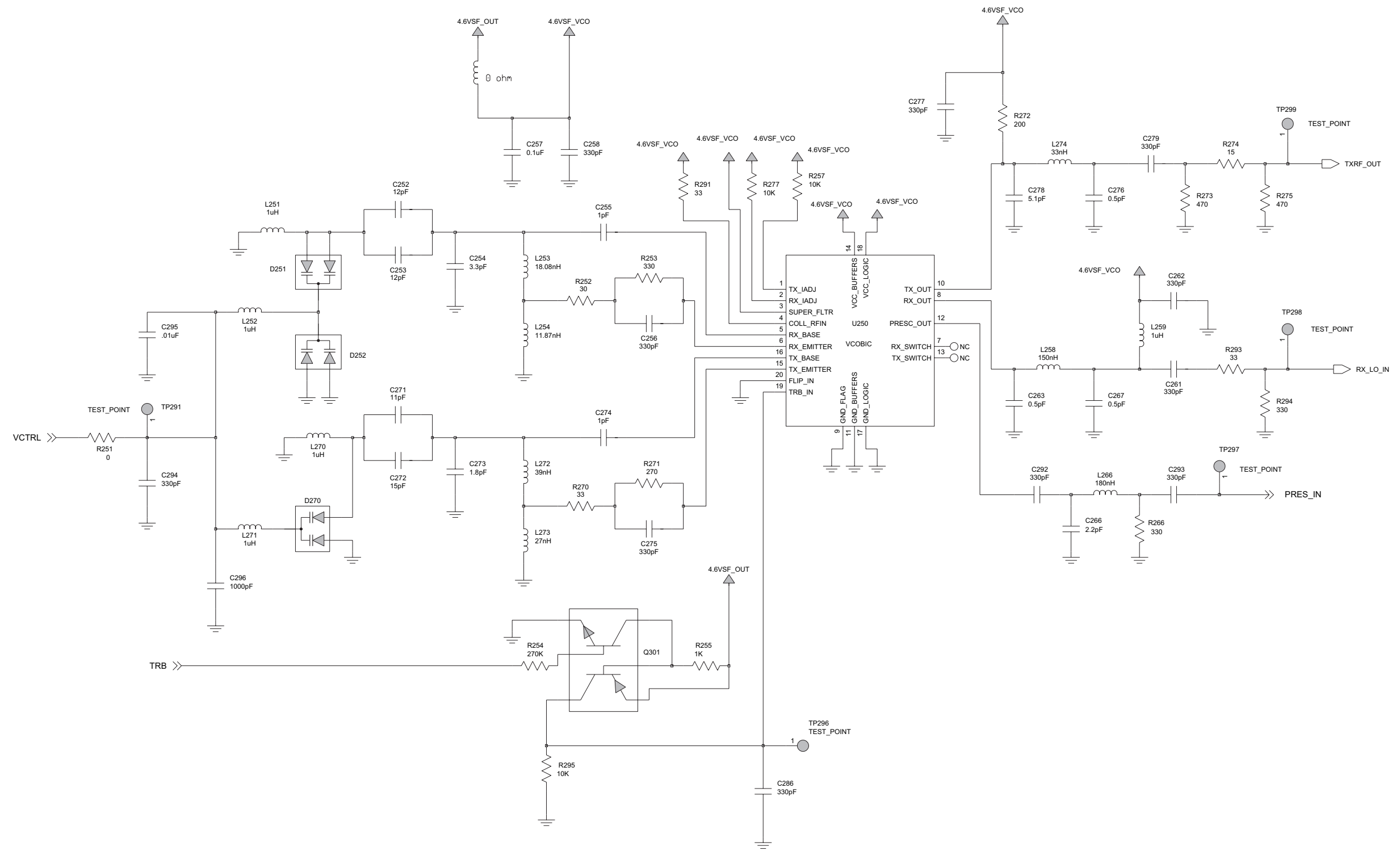

Figure 9.1-13. PMLD4303D Frequency Generation Unit (FGU) Schematic - Sheet 1 of 3



VHF XTS 2500
8485866E01

Figure 9.1-14. PMLD4303A/ PMLD4303D Frequency Generation Unit (FGU) Schematic - Sheet 2 of 3

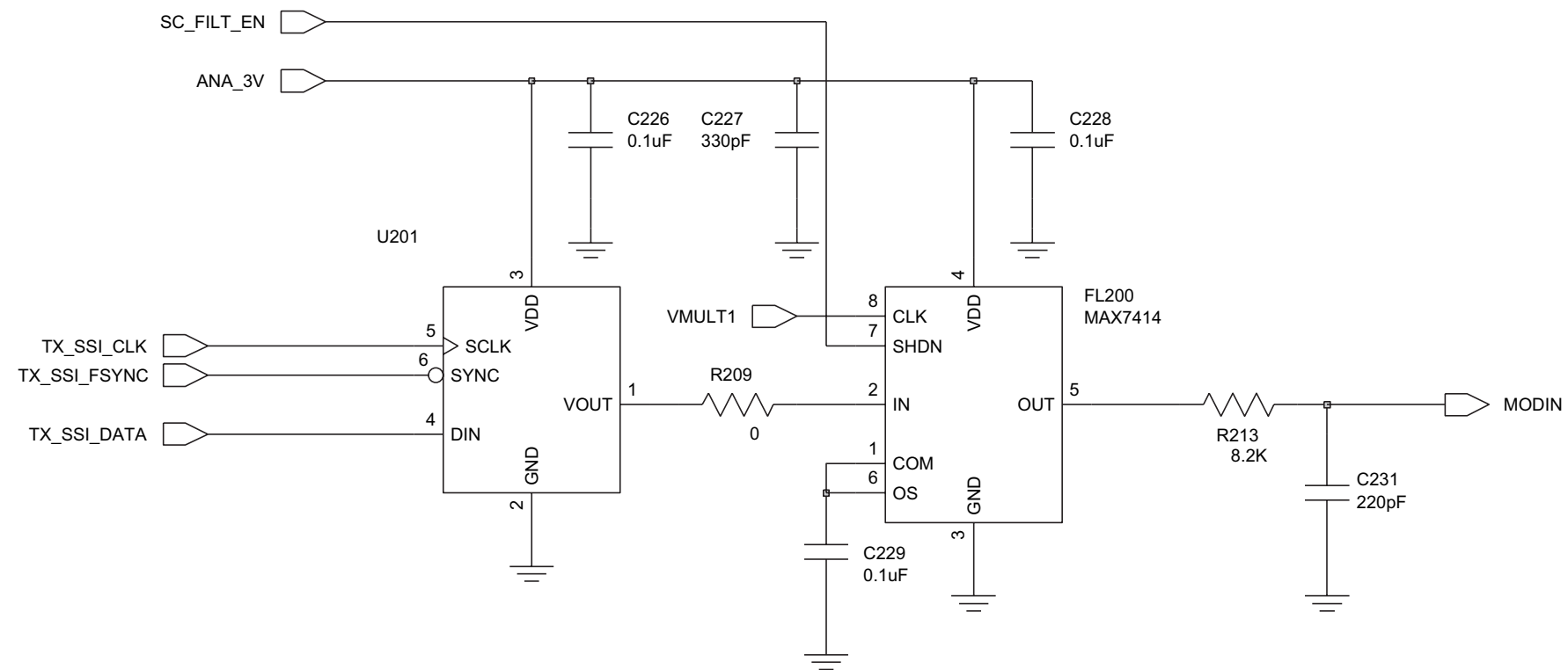

Figure 9.1-15. PMLD4303A/ PMLD4303D Frequency Generation Unit (FGU) Schematic - Sheet 3 of 3

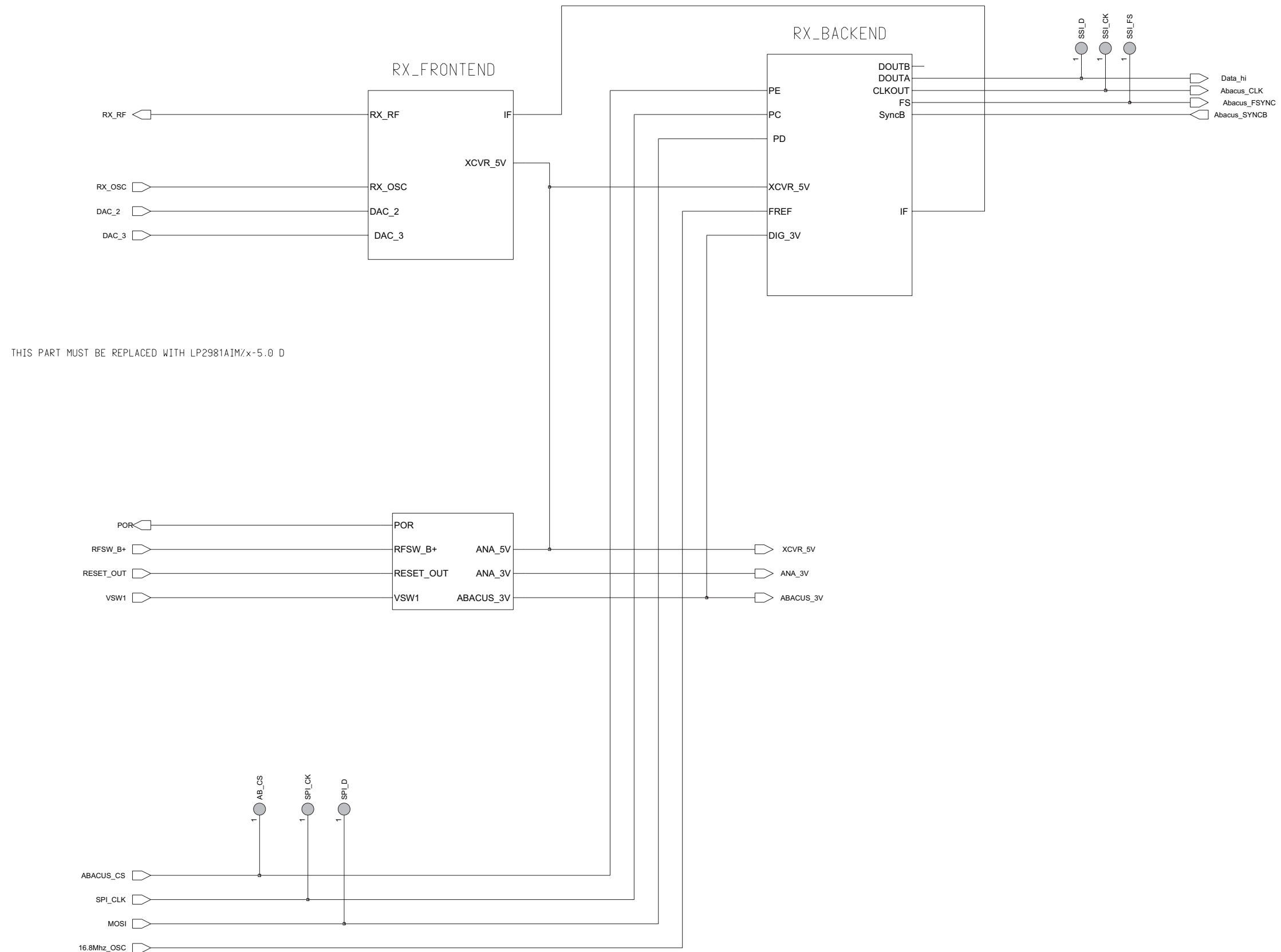

Figure 9.1-16. PMLD4303A/ PMLD4303D Receiver Front End and DC Schematic

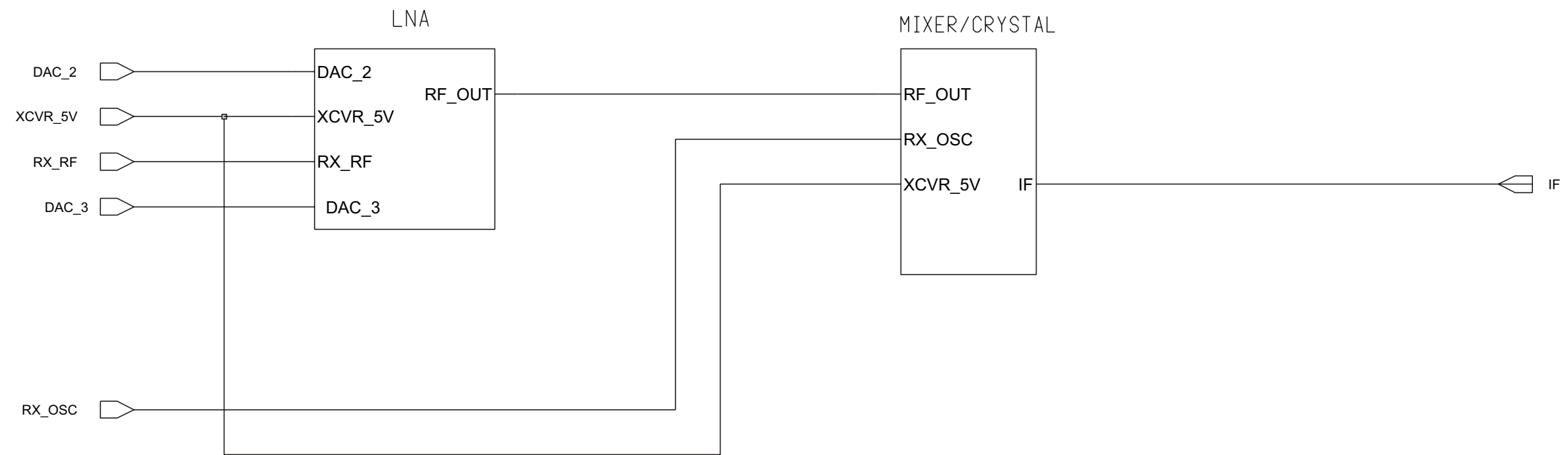

Figure 9.1-17. PMLD4303A/ PMLD4303D Receiver Front End Schematic

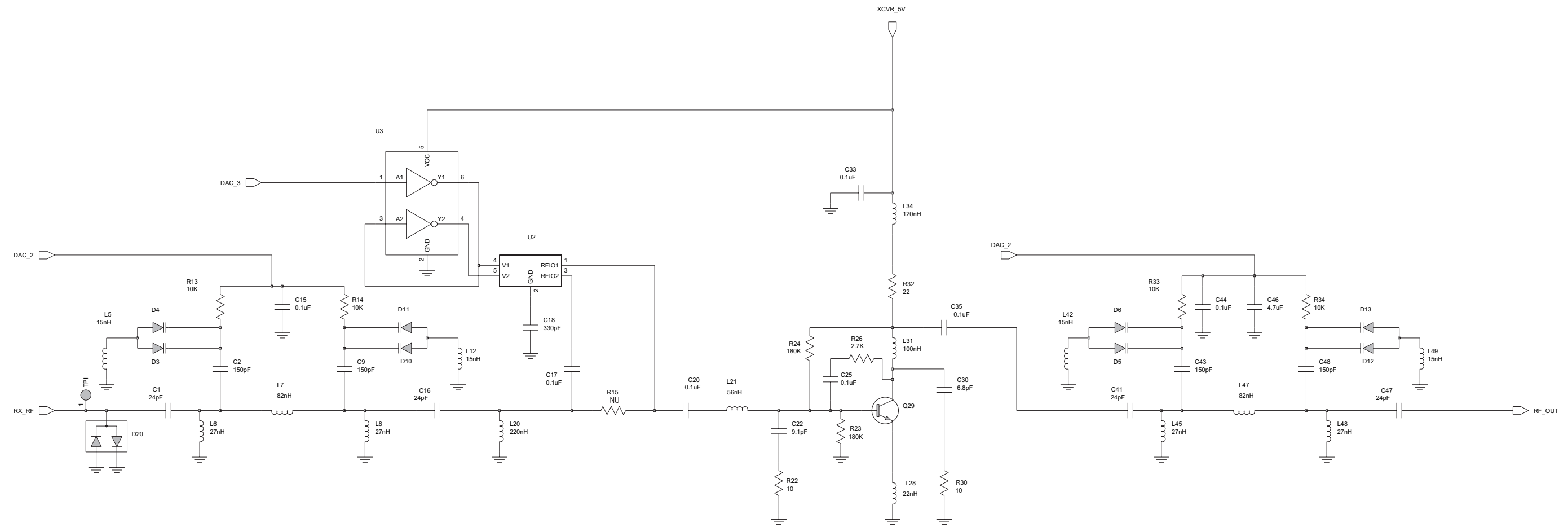

Figure 9.1-18. PMLD4303A/ PMLD4303D Receiver Schematic - Sheet 1 of 4

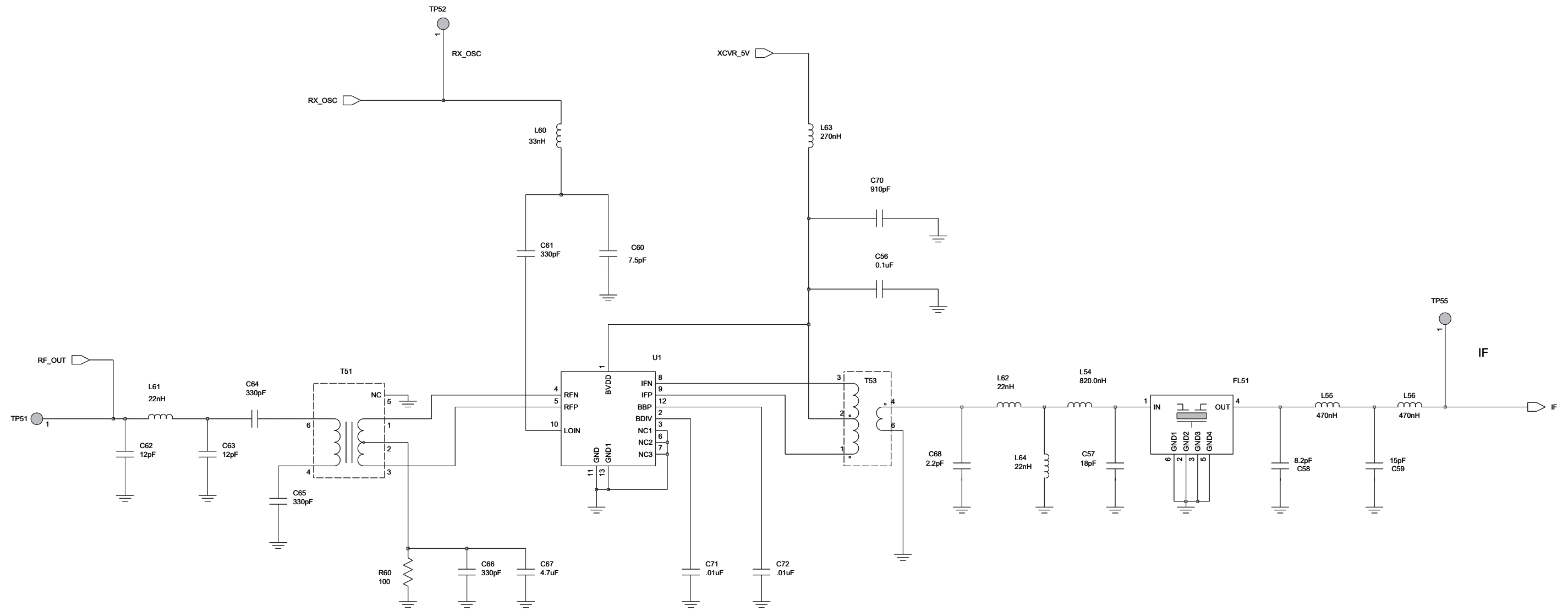

Figure 9.1-19. PMLD4303A/ PMLD4303D Receiver Schematic - Sheet 2 of 4

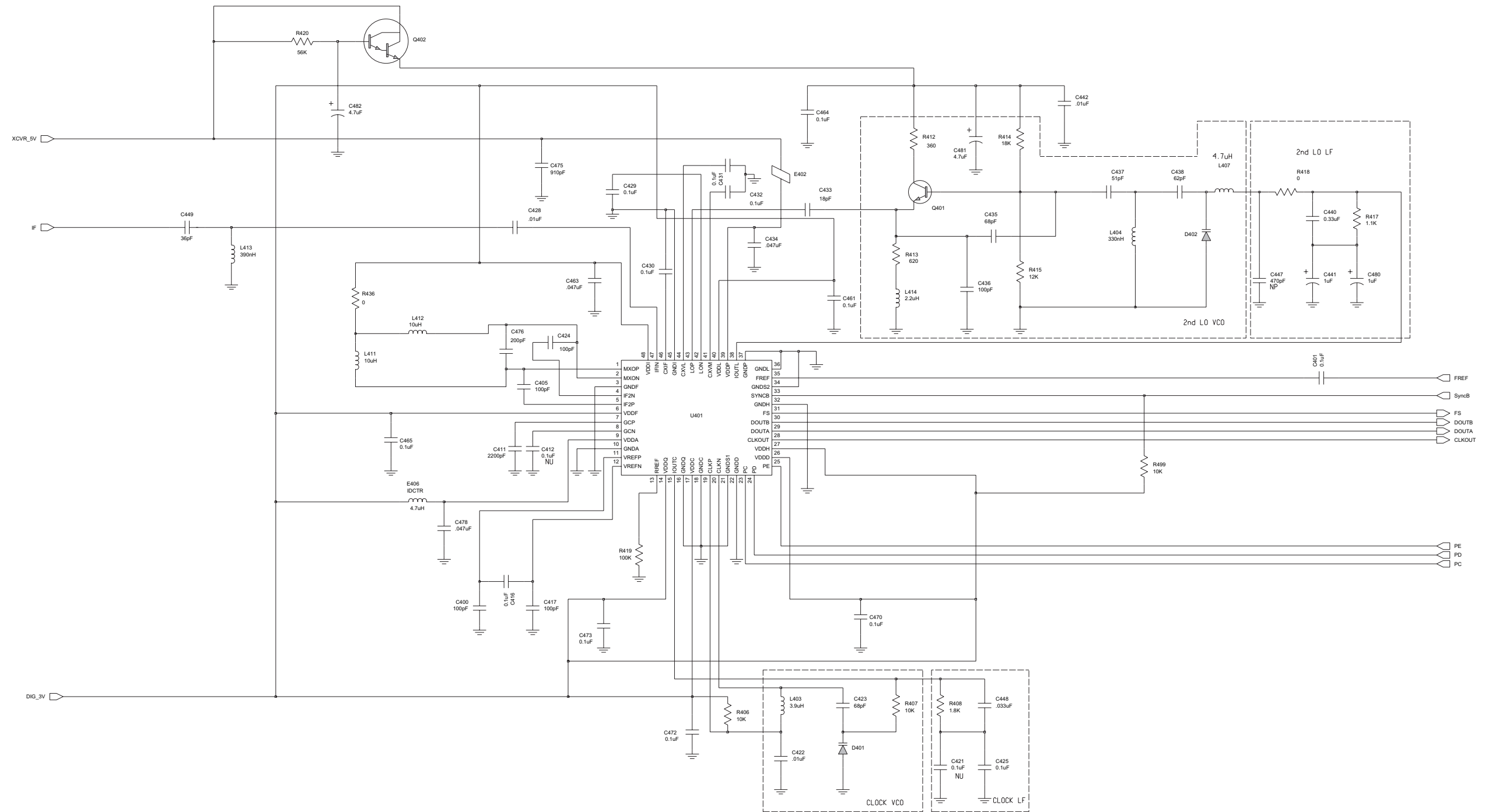

Figure 9.1-20. PMLD4303A/ PMLD4303D Receiver Schematic - Sheet 3 of 4

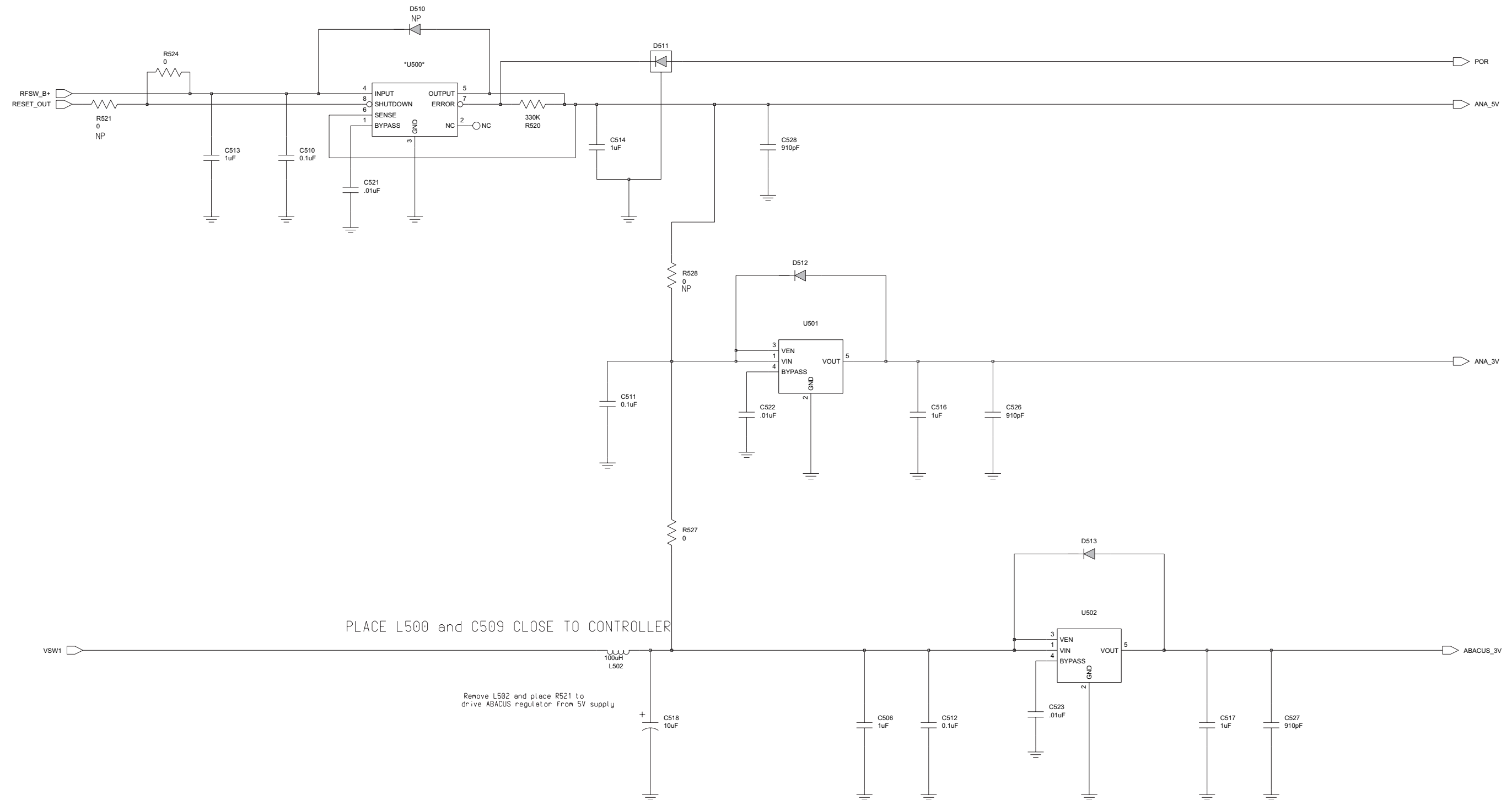

Figure 9.1-21. PMLD4303A/ PMLD4303D Receiver Schematic (Regulators) - Sheet 4 of 4

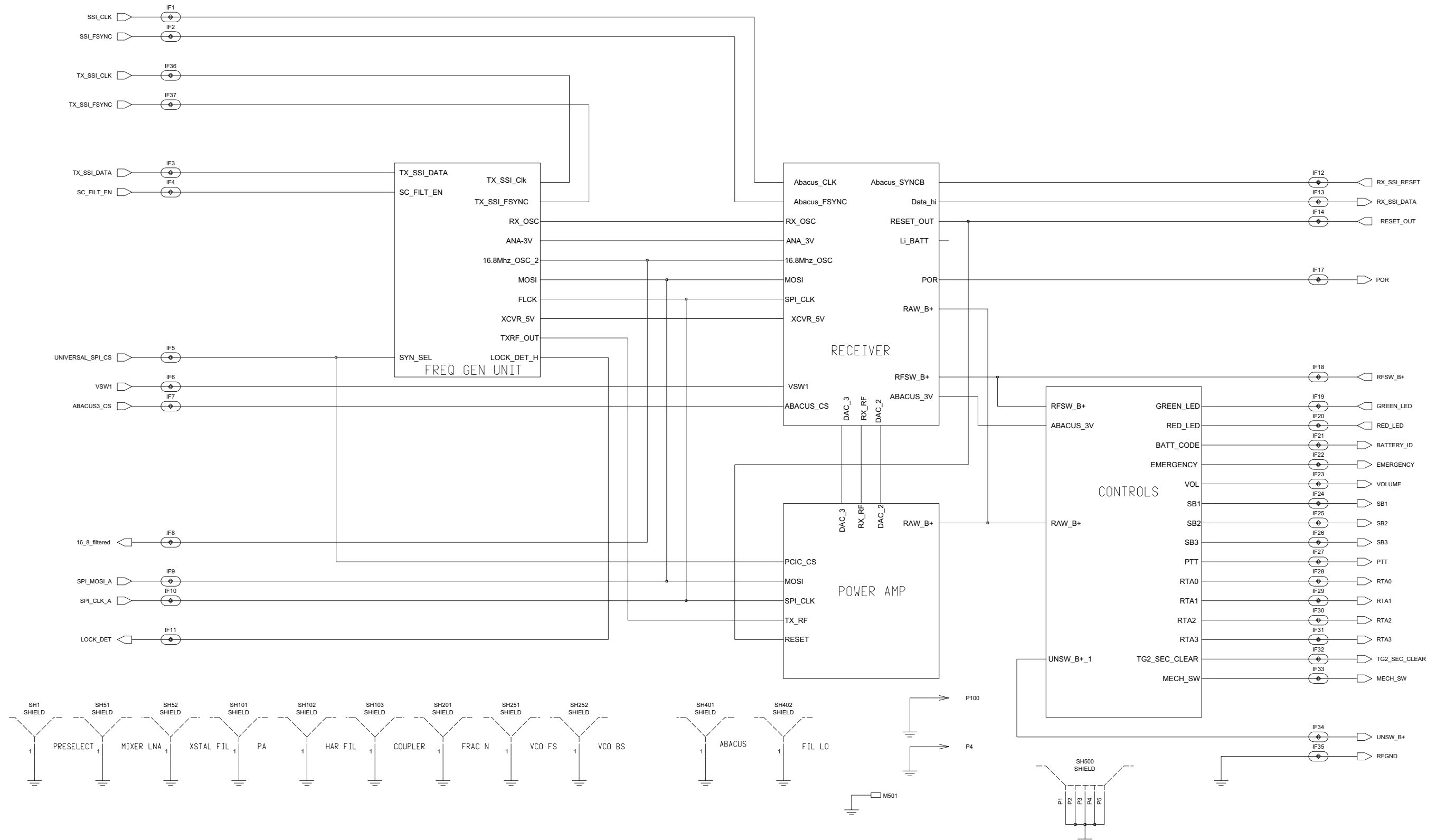

Figure 9.1-22. PMLD4303A/ PMLD4303D RF Schematic

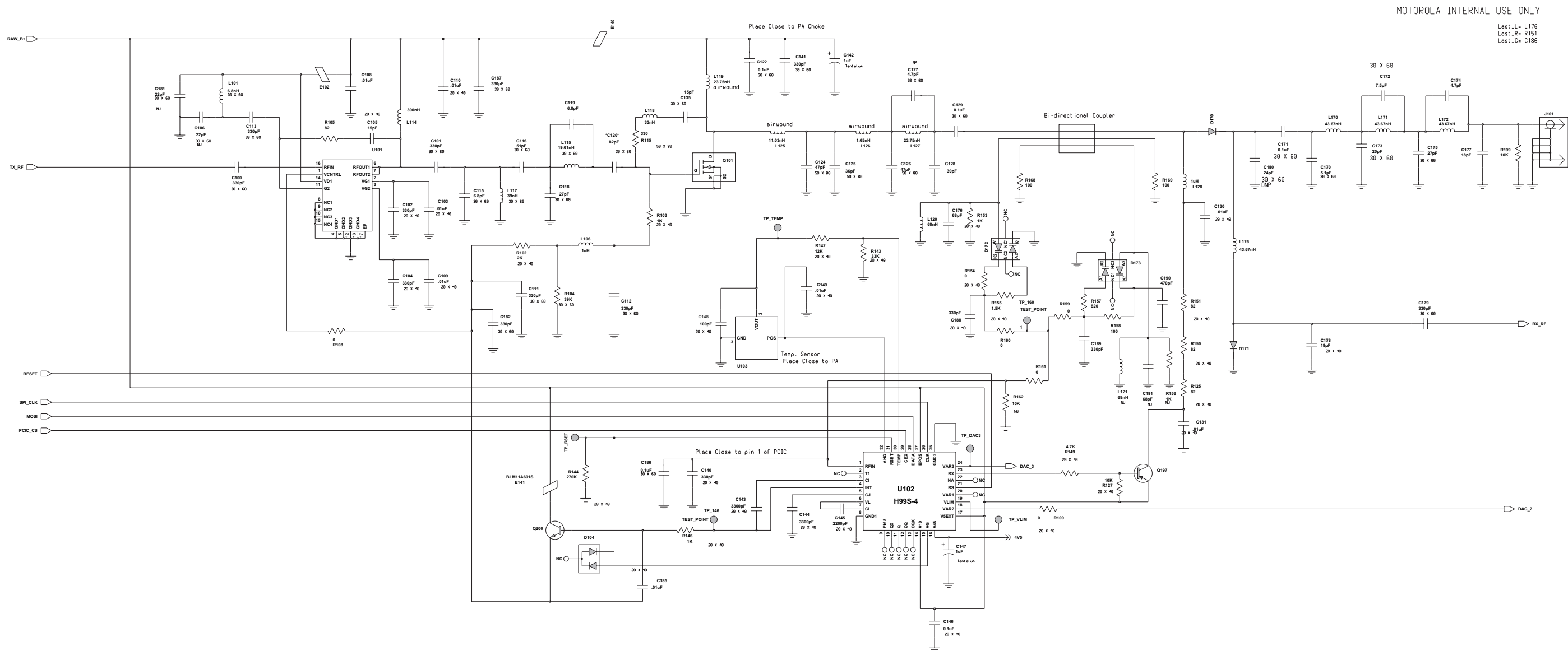

Figure 9.1-23. PMLD4303A/ PMLD4303D Transmitter Schematic

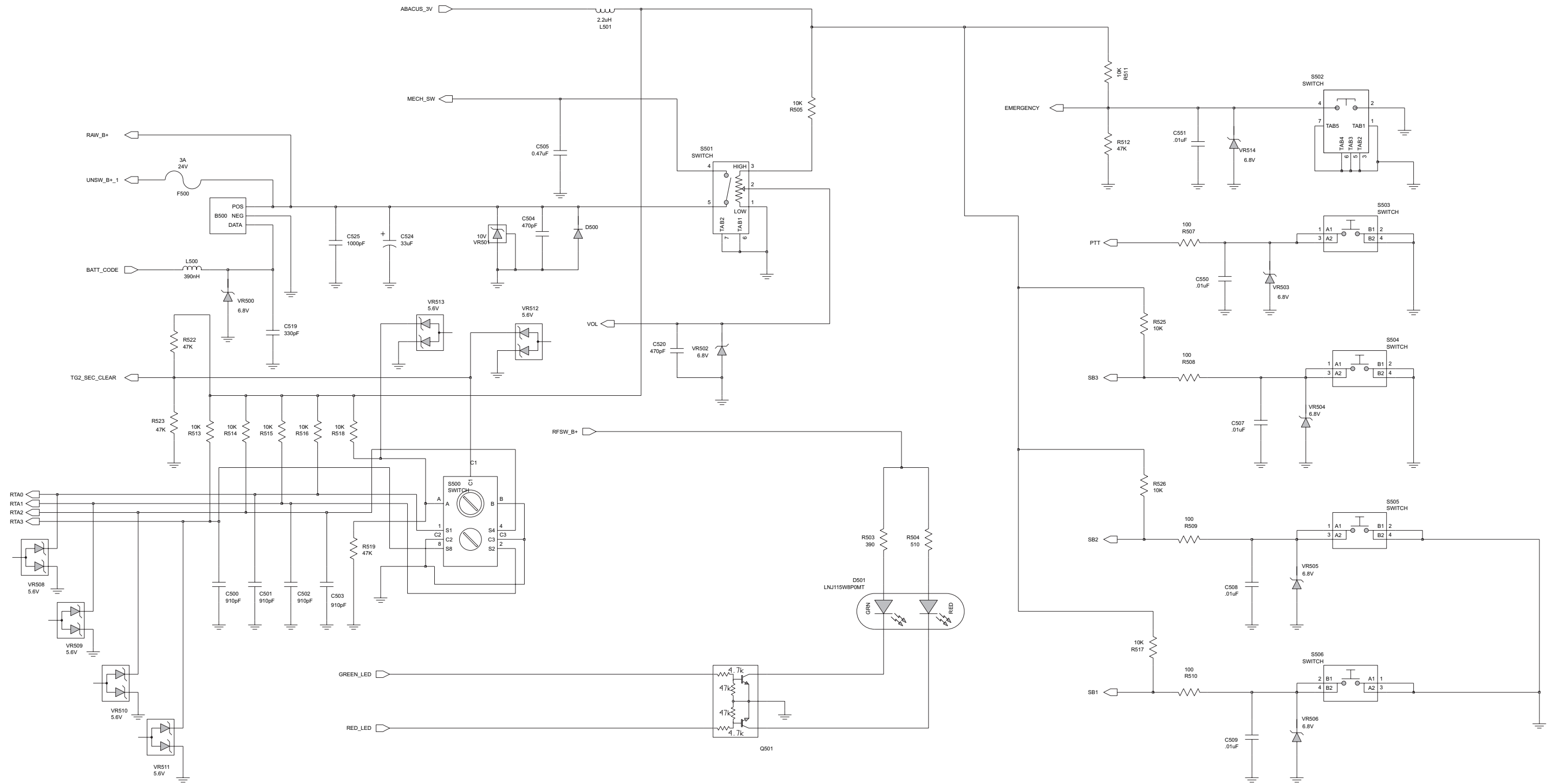

Figure 9.1-24. PMLD4303A RF Controls Schematic

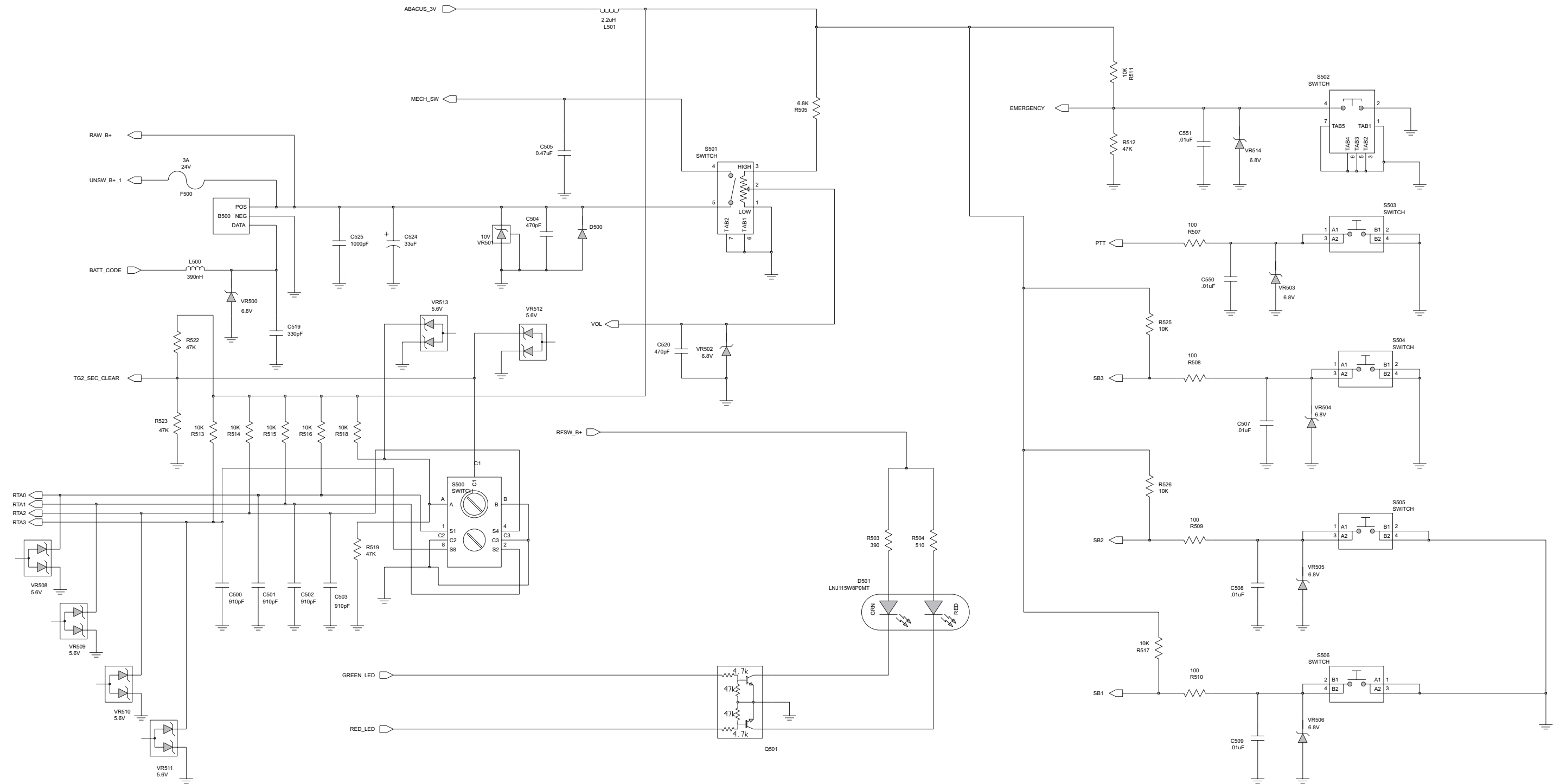

Figure 9.1-25. PMLD4303D RF Controls Schematic

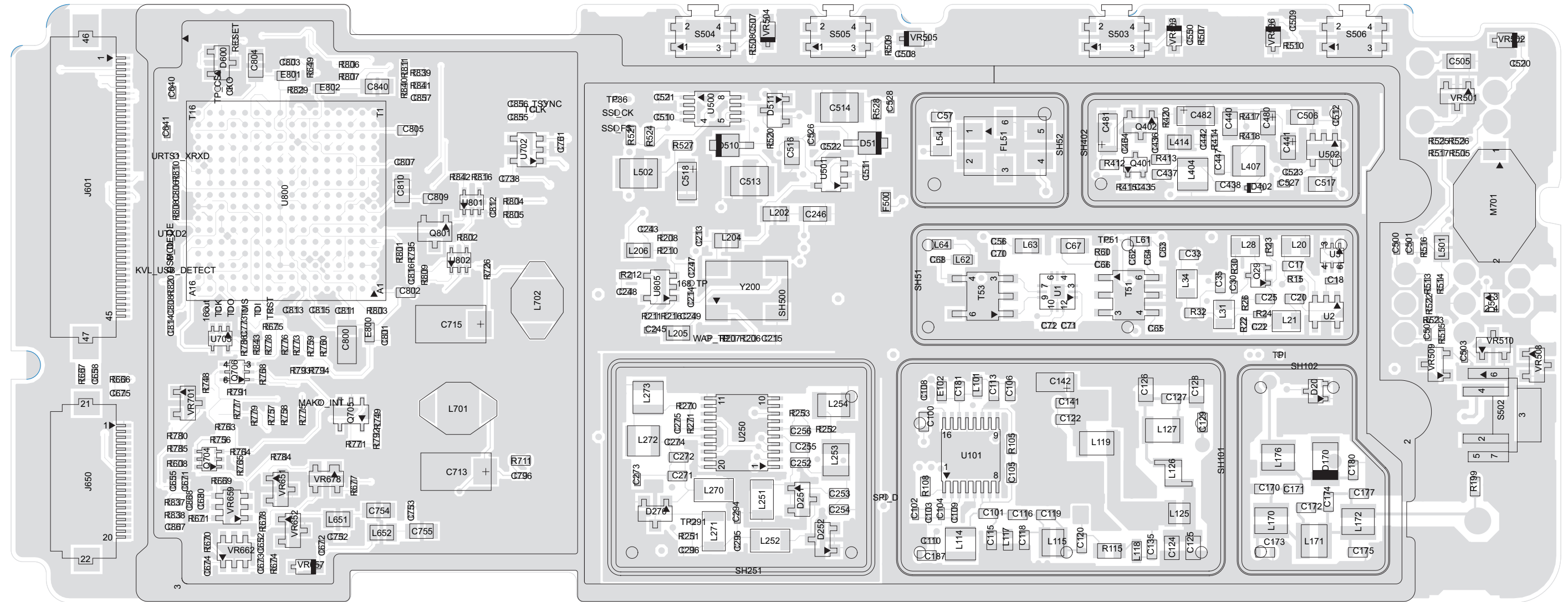

Figure 9.1-26. PMLD4303A/ PMLD4303D Main Circuit Board Component Location Detail - Side 1

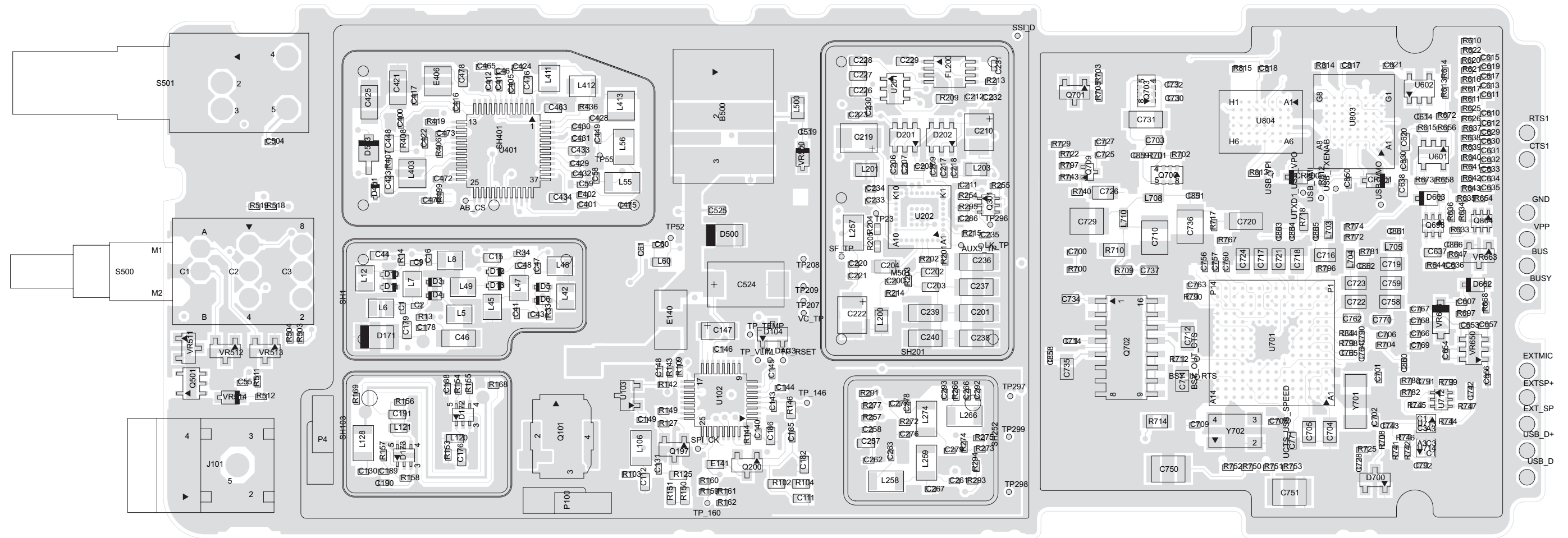

Figure 9.1-27. PMLD4303A/ PMLD4303D Main Circuit Board Component Location Detail - Side 2

PMLD4303A/ PMLD4303D Main Circuit Board
Electrical Parts List

ITEM	MOTOROLA PART NUMBER	DESCRIPTION
B500	0986237A02	CONNECTOR (CONTACT BATTERY)
B500	0986237A02	CONNECTOR (CONTACT BATTERY)
C1	2115075H01	CAP CHIP 24PF 5% COG
C100	2113944C04	CAP CER CHP 330.0PF 50V 5%
C101	2113944C04	CAP CER CHP 330.0PF 50V 5%
C102	2113945A03	CAP CER CHP 330PF 50V 10%
C103	2113945B02	CAP CER CHP 10,000PF 25V 10%
C104	2113945A03	CAP CER CHP 330PF 50V 10%
C105	NOTPLACED	
C106	NOTPLACED	
C108	2113945B02	CAP CER CHP 10,000PF 25V 10%
C109	2113945B02	CAP CER CHP 10,000PF 25V 10%
C110	2113945B02	CAP CER CHP 10,000PF 25V 10%
C111	2113944C04	CAP CER CHP 330.0PF 50V 5%
C112	2113944C04	CAP CER CHP 330.0PF 50V 5%
C113	2113944C04	CAP CER CHP 330.0PF 50V 5%
C115	2113944M14	CAP,FXD,6.8PF,.1PF+/-,50V-DC,0603,C
C116	2113944M35	CAP,FXD,51PF,+2%,-2%,50V-DC,0603,C0
C118	2113944M33	CAP,FXD,43PF,+2%,-2%,50V-DC,0603,C0
C119	2113944M14	CAP,FXD,6.8PF,.1PF+/-,50V-DC,0603,C
C120	2113944C45	CAP CER CHP 100.0PF 50V 5%
C122	2113945C31	CAP,FXD,.1UF,+10%,-10%,50V-DC,0603,
C124	2113944F58	CAP,FXD,47PF,+5%,-5%,50V-DC,0805,C0
C125	2113944F58	CAP,FXD,47PF,+5%,-5%,50V-DC,0805,C0
C126	2113944F58	CAP,FXD,47PF,+5%,-5%,50V-DC,0805,C0

ITEM	MOTOROLA PART NUMBER	DESCRIPTION
C127	2113944M09	CAP,FXD,4.3PF,.1PF+/-,50V-DC,0603
C128	2113944F56	CAP,FXD,39PF,+5%,-5%,50V-DC,0805,C0
C129	2113945L25	CAP,FXD,1000PF,+5%,-5%,50V-DC,0603
C130	2113945B02	CAP CER CHP 10,000PF 25V 10%
C131	2113945B02	CAP CER CHP 10,000PF 25V 10%
C135	2113945L25	CAP,FXD,1000PF,+5%,-5%,50V-DC,0603
C140	2113945A03	CAP CER CHP 330PF 50V 10%
C141	2113944C04	CAP CER CHP 330.0PF 50V 5%
C142	2313960B01	CAP,FXD,1UF,+10%,-10%,16V-DC,SM,-5
C143	2113945A10	CAP CER CHP 1500PF 50V 10%
C144	2113945A05	CAP CER CHP 470PF 50V 10%
C145	2113945B03	CAP,FXD,.015UF,+10%,-10%,25V-DC,040
C146	2113946K02	CAP CER CHP 0.10UF 16V
C147	2313960B01	CAP,FXD,1UF,+10%,-10%,16V-DC,SM,-5
C148	2113944A40	CAP CER CHP 100.0PF 50V 5%
C149	2113945B02	CAP CER CHP 10,000PF 25V 10%
C15	2113945C31	CAP,FXD,.1UF,+10%,-10%,50V-DC,0603,
C16	2115075H01	CAP CHIP 24PF 5% COG
C17	2113945C31	CAP,FXD,.1UF,+10%,-10%,50V-DC,0603,
C170	2113944M27	CAP,FXD,24PF,+2%,-2%,50V-DC,0603,C
C171	2113944C45	CAP CER CHP 100.0PF 50V 5%
C172	2113944M16	CAP,FXD,8.2PF,.1PF+/-,50V-DC,0603,C
C173	2113944M29	CAP,FXD,30PF,+2%,-2%,50V-DC,0603,C
C174	2113944M13	CAP,FXD,6.2PF,.1PF+/-,50V-DC,0603,C
C175	2113944M28	CAP,FXD,27PF,+2%,-2%,50V-DC,0603,C0

ITEM	MOTOROLA PART NUMBER	DESCRIPTION
C176	2113944M20	CAP,FXD,12PF,+2%,-2%,50V-DC,0603,C0
C177	2113944M24	CAP,FXD,18PF,+2%,-2%,50V-DC,0603,C0
C178	2113944A28	CAP CER CHP 18.0PF 50V 5%
C179	2113944C04	CAP CER CHP 330.0PF 50V 5%
C18	2113945A03	CAP CER CHP 330PF 50V 10%
C180	NOTPLACED	
C181	NOTPLACED	
C182	2113944C04	CAP CER CHP 330.0PF 50V 5%
C185	2113945B02	CAP CER CHP 10,000PF 25V 10%
C186	2113945C31	CAP,FXD,.1UF,+10%,-10%,50V-DC,0603,
C187	2113944C04	CAP CER CHP 330.0PF 50V 5%
C188	2113945A03	CAP CER CHP 330PF 50V 10%
C189	2113945A03	CAP CER CHP 330PF 50V 10%
C190	2113945A05	CAP CER CHP 470PF 50V 10%
C191	NOTPLACED	
C2	2113944A42	CAP CER CHP 150.0PF 50V 5%
C20	2113945C31	CAP,FXD,.1UF,+10%,-10%,50V-DC,0603,
C200	2113945A13	CAP CER CHP 4700PF 50V 10%
C201	2109720D14	CAP CER CHIP LOW DIST .1 UF
C202	2113945C27	CAP,FXD,.047UF,+10%,-10%,50V-DC,060
C203	2113945C27	CAP,FXD,.047UF,+10%,-10%,50V-DC,060
C204	2109720D20	CAP CHIP LOW DIST 2000 SOV
C206	2113946K02	CAP CER CHP 0.10UF 16V
C207	2113946K02	CAP CER CHP 0.10UF 16V
C208	2113946K02	CAP CER CHP 0.10UF 16V
C209	2113946K02	CAP CER CHP 0.10UF 16V
C210	2313960D07	CAP,FXD,10,+10,-10,16,SM,-55MIN,12
C211	2113946K02	CAP CER CHP 0.10UF 16V
C212	2113945A03	CAP CER CHP 330PF 50V 10%

ITEM	MOTOROLA PART NUMBER	DESCRIPTION
C213	2113946K02	CAP CER CHP 0.10UF 16V
C214	2113945B02	CAP CER CHP 10,000PF 25V 10%
C215	2113944A40	CAP CER CHP 100.0PF 50V 5%
C217	2113945A03	CAP CER CHP 330PF 50V 10%
C218	2113946K02	CAP CER CHP 0.10UF 16V
C219	2313960D07	CAP,FXD,10,+10,-10,16,SM,-55MIN,12
C22	2113944A24	CAP CER CHP 9.1PF 50V +/- 0.5PF
C220	2113945B02	CAP CER CHP 10,000PF 25V 10%
C221	2113945A03	CAP CER CHP 330PF 50V 10%
C222	2313960D07	CAP,FXD,10,+10,-10,16,SM,-55MIN,12
C223	2113945A03	CAP CER CHP 330PF 50V 10%
C226	2113945C31	CAP,FXD,.1UF,+10%,-10%,50V-DC,0603,
C227	2113945L13	CAP,FXD,330PF,+5%,-5%,50V-DC,0603,X
C228	2113945C31	CAP,FXD,.1UF,+10%,-10%,50V-DC,0603,
C229	2113945C31	CAP,FXD,.1UF,+10%,-10%,50V-DC,0603,
C230	2113946K02	CAP CER CHP 0.10UF 16V
C231	2113945A01	CAP CER CHP 220PF 50V 10%
C232	2113946K02	CAP CER CHP 0.10UF 16V
C233	2113946K02	CAP CER CHP 0.10UF 16V
C234	2113945A03	CAP CER CHP 330PF 50V 10%
C235	2113944A40	CAP CER CHP 100.0PF 50V 5%
C236	2109720D14	CAP CER CHIP LOW DIST .1 UF
C237	2109720D14	CAP CER CHIP LOW DIST .1 UF
C238	2109720D14	CAP CER CHIP LOW DIST .1 UF
C239	2109720D14	CAP CER CHIP LOW DIST .1 UF
C240	2109720D14	CAP CER CHIP LOW DIST .1 UF
C243	2113946K02	CAP CER CHP 0.10UF 16V
C245	2113944A40	CAP CER CHP 100.0PF 50V 5%
C246	2113946N03	CAP CER CHP 2.2UF 16V
C247	2113945A09	CAP CER CHP 1000PF 50V 10%

ITEM	MOTOROLA PART NUMBER	DESCRIPTION
C248	NOTPLACED	
C249	2113945A09	CAP CER CHP 1000PF 50V 10%
C25	2113945C31	CAP,FXD,.1UF,+10%,-10%,50V-DC,0603,
C252	2113944C78	CAP,FXD,13PF,+5%,-5%,50V-DC,0603,C0
C253	2113944C78	CAP,FXD,13PF,+5%,-5%,50V-DC,0603,C0
C254	2113944C18	CAP CER CHP 3.3PF 50V +/- 0.25PF
C255	2113944C63	CAP,FXD,1PF,.1PF+/-,50V-DC,0603,C0G
C256	2113945L13	CAP,FXD,330PF,+5%,-5%,50V-DC,0603,X
C257	2113945C31	CAP,FXD,.1UF,+10%,-10%,50V-DC,0603,
C258	2113945A03	CAP CER CHP 330PF 50V 10%
C261	2113945A03	CAP CER CHP 330PF 50V 10%
C262	2113945A03	CAP CER CHP 330PF 50V 10%
C263	2113944A61	CAP,FXD,.5PF,.25PF+/-,50V-DC,0402,C
C266	2113944A09	CAP CER CHP 2.2PF 50V +/- 0.25PF
C267	2113944A61	CAP,FXD,.5PF,.25PF+/-,50V-DC,0402,C
C271	2113944C32	CAP CER CHP 15.0PF 50V 5%
C272	2113944C32	CAP CER CHP 15.0PF 50V 5%
C273	2188881Y12	CAP,CERAMIC CHIP,1.8PF,.1PF+/-,16
C274	2113944V03	CAP,FXD,1PF,.1PF+/-,50V-DC,0402,C0G
C275	2113945A03	CAP CER CHP 330PF 50V 10%
C276	2113944A61	CAP,FXD,.5PF,.25PF+/-,50V-DC,0402,C
C277	2113945A03	CAP CER CHP 330PF 50V 10%
C278	2113944A18	CAP CER CHP 5.1PF 50V +/- 0.5PF
C279	2113945A03	CAP CER CHP 330PF 50V 10%
C286	2113945A03	CAP CER CHP 330PF 50V 10%
C292	2113945A03	CAP CER CHP 330PF 50V 10%

ITEM	MOTOROLA PART NUMBER	DESCRIPTION
C293	2113945A03	CAP CER CHP 330PF 50V 10%
C294	2113945A03	CAP CER CHP 330PF 50V 10%
C295	2113945B02	CAP CER CHP 10,000PF 25V 10%
C296	2113945A09	CAP CER CHP 1000PF 50V 10%
C30	2113944A21	CAP CER CHP 6.8PF 50V +/- 0.5PF
C33	2113945C31	CAP,FXD,.1UF,+10%,-10%,50V-DC,0603,
C35	2113945C31	CAP,FXD,.1UF,+10%,-10%,50V-DC,0603,
C400	2113944A40	CAP CER CHP 100.0PF 50V 5%
C401	2113946K02	CAP CER CHP 0.10UF 16V
C405	2113944A40	CAP CER CHP 100.0PF 50V 5%
C41	2115075H01	CAP CHIP 24PF 5% COG
C411	2113945A11	CAP CER CHP 2200PF 50V 10%
C412	NOTPLACED	
C416	2113946K02	CAP CER CHP 0.10UF 16V
C417	2113944A40	CAP CER CHP 100.0PF 50V 5%
C421	NOTPLACED	
C422	2113945B02	CAP CER CHP 10,000PF 25V 10%
C423	2113944C41	CAP CER CHP 68.0PF 50V 5%
C424	2113944A40	CAP CER CHP 100.0PF 50V 5%
C425	2113945H69	CAP,FXD,.1UF,+5%,-5%,50V-DC,1206,X
C428	2113944A29	CAP CER CHP 22.0PF 50V 5%
C429	2113946K02	CAP CER CHP 0.10UF 16V
C43	2113944A42	CAP CER CHP 150.0PF 50V 5%
C430	2113946K02	CAP CER CHP 0.10UF 16V
C431	2113946K02	CAP CER CHP 0.10UF 16V
C432	2113946K02	CAP CER CHP 0.10UF 16V
C433	2113944C33	CAP CER CHP 18.0PF 50V 5%
C434	2113945C27	CAP,FXD,.047UF,+10%,-10%,50V-DC,060
C435	2113944A36	CAP CER CHP 68.0PF 50V 5%
C436	2113944A40	CAP CER CHP 100.0PF 50V 5%

ITEM	MOTOROLA PART NUMBER	DESCRIPTION
C437	2113944C85	CAP,FXD,51PF,+5%,-5%,50V-DC,0603,C0
C438	2113944C40	CAP CER CHP 62.0PF 50V 5%
C44	2113945C31	CAP,FXD,.1UF,+10%,-10%,50V-DC,0603,
C440	2113945G96	CAP,FXD,.33UF,+10%,-10%,50V-DC,0805
C441	2313960M26	CAP,FXD,1UF,+10%,-10%,10V-DC,SM,-5
C442	2113945B02	CAP CER CHP 10,000PF 25V 10%
C447	NOTPLACED	
C448	2113945C25	CAP,FXD,.033UF,+10%,-10%,50V-DC,060
C449	2113944A79	CAP,FXD,16PF,+5%,-5%,50V-DC,0402,C0
C46	2113946Q01	CAP CER CHP 4.7UF 16V
C461	2113946K02	CAP CER CHP 0.10UF 16V
C463	2113945C27	CAP,FXD,.047UF,+10%,-10%,50V-DC,060
C464	2113946K02	CAP CER CHP 0.10UF 16V
C465	2113946K02	CAP CER CHP 0.10UF 16V
C47	2115075H01	CAP CHIP 24PF 5% COG
C470	2113946K02	CAP CER CHP 0.10UF 16V
C472	2113946K02	CAP CER CHP 0.10UF 16V
C473	2113946K02	CAP CER CHP 0.10UF 16V
C475	2113945A58	CAP,FXD,910PF,+10%,-10%,50V-DC,0402
C476	2113944C89	CAP,FXD,200PF,+5%,-5%,50V-DC,0603,C
C478	2113945C27	CAP,FXD,.047UF,+10%,-10%,50V-DC,060
C48	2113944A42	CAP CER CHP 150.0PF 50V 5%
C480	2313960M26	CAP,FXD,1UF,+10%,-10%,10V-DC,SM,-5
C481	2313960B30	CAP,FXD,4.7UF,+10%,-10%,10V-DC,SM,
C482	2313960B30	CAP,FXD,4.7UF,+10%,-10%,10V-DC,SM,

ITEM	MOTOROLA PART NUMBER	DESCRIPTION
C500	2113945A58	CAP,FXD,910PF,+10%,-10%,50V-DC,0402
C501	2113945A58	CAP,FXD,910PF,+10%,-10%,50V-DC,0402
C502	2113945A58	CAP,FXD,910PF,+10%,-10%,50V-DC,0402
C503	2113945A58	CAP,FXD,910PF,+10%,-10%,50V-DC,0402
C504	2113945A03	CAP CER CHP 330PF 50V 10%
C505	2113945G98	CAP,FXD,.47UF,+10%,-10%,50V-DC,0805
C506	2113946E02	CAP CER CHP 1.0UF 16V 10%
C507	2113945B02	CAP CER CHP 10,000PF 25V 10%
C508	2113945B02	CAP CER CHP 10,000PF 25V 10%
C509	2113945B02	CAP CER CHP 10,000PF 25V 10%
C510	2113946K02	CAP CER CHP 0.10UF 16V
C511	2113946K02	CAP CER CHP 0.10UF 16V
C512	2113946K02	CAP CER CHP 0.10UF 16V
C513	2113955E11	CAP,FXD,1UF,+10%,-10%,50V
C514	2113955E11	CAP,FXD,1UF,+10%,-10%,50V
C516	2113946E02	CAP CER CHP 1.0UF 16V 10%
C517	2113946E02	CAP CER CHP 1.0UF 16V 10%
C518	2313960B57	CAP,FXD,10UF,+10%,-10%,6.3V-DC,SM,-
C519	2113945A58	CAP,FXD,910PF,+10%,-10%,50V-DC,0402
C520	2113945A05	CAP CER CHP 470PF 50V 10%
C521	2113945B02	CAP CER CHP 10,000PF 25V 10%
C522	2113945B02	CAP CER CHP 10,000PF 25V 10%
C523	2113945B02	CAP CER CHP 10,000PF 25V 10%
C524	2313960H04	CAP,FXD,33UF,+10%,-10%,16V-DC,SM,-5
C525	2113945L25	CAP,FXD,1000PF,+5%,-5%,50V-DC,0603
C526	2113945A58	CAP,FXD,910PF,+10%,-10%,50V-DC,0402
C527	2113945A58	CAP,FXD,910PF,+10%,-10%,50V-DC,0402

ITEM	MOTOROLA PART NUMBER	DESCRIPTION
C528	2113945A58	CAP,FXD,910PF,+10%,-10%,50V-DC,0402
C550	2113945B02	CAP CER CHP 10,000PF 25V 10%
C551	2113945B02	CAP CER CHP 10,000PF 25V 10%
C56	2113946B04	CAP CER CHP 0.10UF 10V 10%
C57	2113944C33	CAP CER CHP 18.0PF 50V 5%
C58	NOTPLACED	
C59	2113944A28	CAP CER CHP 18.0PF 50V 5%
C60	2113944A22	CAP CER CHP 7.5PF 50V +/- 0.5PF
C607	2113946K02	CAP CER CHP 0.10UF 16V
C61	2113945A03	CAP CER CHP 330PF 50V 10%
C610	2113944A32	CAP CER CHP 39.0PF 50V 5%
C611	2113944A32	CAP CER CHP 39.0PF 50V 5%
C612	2113944A32	CAP CER CHP 39.0PF 50V 5%
C613	2113944A32	CAP CER CHP 39.0PF 50V 5%
C614	2113945A03	CAP CER CHP 330PF 50V 10%
C615	2113944A32	CAP CER CHP 39.0PF 50V 5%
C617	2113944A32	CAP CER CHP 39.0PF 50V 5%
C619	2113944A32	CAP CER CHP 39.0PF 50V 5%
C62	2113944A26	CAP CER CHP 12.0PF 50V 5%
C620	2113945C31	CAP,FXD,.1UF,+10%,-10%,50V-DC,0603,
C621	2113946K02	CAP CER CHP 0.10UF 16V
C629	2113945A03	CAP CER CHP 330PF 50V 10%
C63	2113944A26	CAP CER CHP 12.0PF 50V 5%
C630	2113945A03	CAP CER CHP 330PF 50V 10%
C631	2113945A03	CAP CER CHP 330PF 50V 10%
C632	2113945A03	CAP CER CHP 330PF 50V 10%
C633	2113945A03	CAP CER CHP 330PF 50V 10%
C634	2113945A03	CAP CER CHP 330PF 50V 10%
C635	2113945A03	CAP CER CHP 330PF 50V 10%
C636	2113945A03	CAP CER CHP 330PF 50V 10%
C637	2113945L49	CAP,FXD,.01UF,+5%,-5%,50V-DC,0603,

ITEM	MOTOROLA PART NUMBER	DESCRIPTION
C638	2113945C31	CAP,FXD,.1UF,+10%,-10%,50V-DC,0603,
C64	2113945A03	CAP CER CHP 330PF 50V 10%
C640	NOTPLACED	
C641	NOTPLACED	
C65	2113945A03	CAP CER CHP 330PF 50V 10%
C652	2113945A58	CAP,FXD,910PF,+10%,-10%,50V-DC,0402
C653	2113945A58	CAP,FXD,910PF,+10%,-10%,50V-DC,0402
C654	2113945A58	CAP,FXD,910PF,+10%,-10%,50V-DC,0402
C655	2113945A58	CAP,FXD,910PF,+10%,-10%,50V-DC,0402
C656	2113945A58	CAP,FXD,910PF,+10%,-10%,50V-DC,0402
C657	2113945A58	CAP,FXD,910PF,+10%,-10%,50V-DC,0402
C658	2113945A58	CAP,FXD,910PF,+10%,-10%,50V-DC,0402
C66	2113945A03	CAP CER CHP 330PF 50V 10%
C67	2113946F03	CAP CER CHP 4.7UF 6.3V 10%
C671	2113944A31	CAP CER CHP 33.0PF 50V 5%
C672	2113945A58	CAP,FXD,910PF,+10%,-10%,50V-DC,0402
C673	2113944A31	CAP CER CHP 33.0PF 50V 5%
C674	2113945A05	CAP CER CHP 470PF 50V 10%
C675	2113945A58	CAP,FXD,910PF,+10%,-10%,50V-DC,0402
C68	2113944A09	CAP CER CHP 2.2PF 50V +/- 0.25PF
C680	2113944A31	CAP CER CHP 33.0PF 50V 5%
C70	2113945A58	CAP,FXD,910PF,+10%,-10%,50V-DC,0402
C700	2113946B04	CAP CER CHP 0.10UF 10V 10%
C701	2113944A19	CAP CER CHP 5.6PF 50V +/- 0.5PF
C702	2113944A19	CAP CER CHP 5.6PF 50V +/- 0.5PF
C703	NOTPLACED	

ITEM	MOTOROLA PART NUMBER	DESCRIPTION
C704	2113946F01	CAP CER CHP 2.2UF 6.3V 10%
C705	2113946F01	CAP CER CHP 2.2UF 6.3V 10%
C706	2113945A09	CAP CER CHP 1000PF 50V 10%
C708	2113944A31	CAP CER CHP 33.0PF 50V 5%
C709	2113944A31	CAP CER CHP 33.0PF 50V 5%
C71	2113945B02	CAP CER CHP 10,000PF 25V 10%
C710	2113946J03	CAP CER CHP 10.0UF 16V 10%
C711	2113946F03	CAP CER CHP 4.7UF 6.3V 10%
C712	2113946E02	CAP CER CHP 1.0UF 16V 10%
C713	2311049C70 (PMLD4303A) 2314030F56 (PMLD4303D)	CAP,FXD,68UF,+10%,-10%,10V-DC,SM,-5 CAP,FXD,68UF,+10%,-10%,10V-DC,SM,-5
C714	2113945A09	CAP CER CHP 1000PF 50V 10%
C715	2311049A99 (PMLD4303A) 2313960F30 (PMLD4303D)	CAP TANT CHIP 47UF 10V 20% CAP TANT CHIP 47UF 10V 20%
C716	2113946F01	CAP CER CHP 2.2UF 6.3V 10%
C717	2113946E02	CAP CER CHP 1.0UF 16V 10%
C718	2113946F01	CAP CER CHP 2.2UF 6.3V 10%
C719	2113946E02	CAP CER CHP 1.0UF 16V 10%
C72	2113945B02	CAP CER CHP 10,000PF 25V 10%
C720	2113946G01	CAP CER CHP 2.2UF 16V 10%
C721	2113946E02	CAP CER CHP 1.0UF 16V 10%
C722	2113946E02	CAP CER CHP 1.0UF 16V 10%
C723	2113946E02	CAP CER CHP 1.0UF 16V 10%
C724	2113946E02	CAP CER CHP 1.0UF 16V 10%
C725	2113946K02	CAP CER CHP 0.10UF 16V
C726	2113944F07	CAP CER CHP 1000PF +5%, -5%, 50V-DC 0805
C727	2113944A40	CAP CER CHP 100.0PF 50V 5%
C728	2113945A58	CAP,FXD,910PF,+10%,-10%,50V-DC,0402
C729	2113946J03	CAP CER CHP 10.0UF 16V 10%
C730	2113944A40	CAP CER CHP 100.0PF 50V 5%

ITEM	MOTOROLA PART NUMBER	DESCRIPTION
C731	2113946G01	CAP CER CHP 2.2UF 16V 10%
C732	2113944A40	CAP CER CHP 100.0PF 50V 5%
C734	2113945C31	CAP,FXD,.1UF,+10%,-10%,50V-DC,0603,
C735	2113946E02	CAP CER CHP 1.0UF 16V 10%
C736	2113946J03	CAP CER CHP 10.0UF 16V 10%
C737	2113945C31	CAP,FXD,.1UF,+10%,-10%,50V-DC,0603,
C738	2113946K02	CAP CER CHP 0.10UF 16V
C742	2113945A05	CAP CER CHP 470PF 50V 10%
C743	2113944A25	CAP CER CHP 10.0PF 50V +/- 0.5PF
C750	2113946J03	CAP CER CHP 10.0UF 16V 10%
C751	2113946J03	CAP CER CHP 10.0UF 16V 10%
C752	2113944A40	CAP CER CHP 100.0PF 50V 5%
C753	2113944A40	CAP CER CHP 100.0PF 50V 5%
C754	2113946E02	CAP CER CHP 1.0UF 16V 10%
C755	2113946E02	CAP CER CHP 1.0UF 16V 10%
C756	2113944A40	CAP CER CHP 100.0PF 50V 5%
C757	2113944A40	CAP CER CHP 100.0PF 50V 5%
C758	2113946E02	CAP CER CHP 1.0UF 16V 10%
C759	2113946E02	CAP CER CHP 1.0UF 16V 10%
C760	2113944A40	CAP CER CHP 100.0PF 50V 5%
C761	2113944A40	CAP CER CHP 100.0PF 50V 5%
C762	2113945C31	CAP,FXD,.1UF,+10%,-10%,50V-DC,0603,
C763	2113944A40	CAP CER CHP 100.0PF 50V 5%
C764	2113946B03	CAP CER CHP 0.068UF 10V 10%
C765	2113946B03	CAP CER CHP 0.068UF 10V 10%
C766	2113944A40	CAP CER CHP 100.0PF 50V 5%
C767	2113944A40	CAP CER CHP 100.0PF 50V 5%
C768	2113944A40	CAP CER CHP 100.0PF 50V 5%
C769	2113944A40	CAP CER CHP 100.0PF 50V 5%
C770	2113945C31	CAP,FXD,.1UF,+10%,-10%,50V-DC,0603,

ITEM	MOTOROLA PART NUMBER	DESCRIPTION
C771	2113945C31	CAP,FXD,.1UF,+10%,-10%,50V-DC,0603,
C773	2113946K02	CAP CER CHP 0.10UF 16V
C790	2113946A02	CAP CER CHP 0.022UF 16V 10%
C791	2113946K02	CAP CER CHP 0.10UF 16V
C792	2113946K02	CAP CER CHP 0.10UF 16V
C796	NOTPLACED	
C800	2113955D31	CAP,FXD,1UF,+10%,-10%,16V-DC,1206,X
C801	2113945A05	CAP CER CHP 470PF 50V 10%
C802	2113945C20	CAP,FXD,.016UF,+10%,-10%,50V-DC,060
C803	2113945A05	CAP CER CHP 470PF 50V 10%
C804	2113946E02	CAP CER CHP 1.0UF 16V 10%
C805	2113945C20	CAP,FXD,.016UF,+10%,-10%,50V-DC,060
C806	2113946K02	CAP CER CHP 0.10UF 16V
C807	2113946K02	CAP CER CHP 0.10UF 16V
C808	2113946K02	CAP CER CHP 0.10UF 16V
C809	2113945C20	CAP,FXD,.016UF,+10%,-10%,50V-DC,060
C810	2113946E02	CAP CER CHP 1.0UF 16V 10%
C811	2113946K02	CAP CER CHP 0.10UF 16V
C812	2113946K02	CAP CER CHP 0.10UF 16V
C813	2113946K02	CAP CER CHP 0.10UF 16V
C814	2113946K02	CAP CER CHP 0.10UF 16V
C815	2113946K02	CAP CER CHP 0.10UF 16V
C816	2113946K02	CAP CER CHP 0.10UF 16V
C817	2113946K02	CAP CER CHP 0.10UF 16V
C818	2113946K02	CAP CER CHP 0.10UF 16V
C830	2113946K02	CAP CER CHP 0.10UF 16V
C840	2113946F03	CAP CER CHP 4.7UF 6.3V 10%
C850	2113945A03	CAP CER CHP 330PF 50V 10%
C851	2113944A40	CAP CER CHP 100.0PF 50V 5%
C855	NOTPLACED	

ITEM	MOTOROLA PART NUMBER	DESCRIPTION
C856	NOTPLACED	
C857	NOTPLACED	
C858	2113945B02	CAP CER CHP 10,000PF 25V 10%
C859	2113945B02	CAP CER CHP 10,000PF 25V 10%
C860	2113945B02	CAP CER CHP 10,000PF 25V 10%
C861	2113945B02	CAP CER CHP 10,000PF 25V 10%
C862	2113945B02	CAP CER CHP 10,000PF 25V 10%
C863	2113945B02	CAP CER CHP 10,000PF 25V 10%
C864	2113945B02	CAP CER CHP 10,000PF 25V 10%
C865	2113945B02	CAP CER CHP 10,000PF 25V 10%
C866	2113945B02	CAP CER CHP 10,000PF 25V 10%
C867	NOTPLACED	
C868	NOTPLACED	
C9	2113944A42	CAP CER CHP 150.0PF 50V 5%
CR800	4813978A25	DIODE, SCHOTTKY 30V SOD-323 T&R
CR801	4813978A25	DIODE, SCHOTTKY 30V SOD-323 T&R
D10	4815096H01	VARACTOR DIODE 1SV305
D104	4816487H01	DIODE MMBD7000
D11	4815096H01	VARACTOR DIODE 1SV305
D12	4815096H01	VARACTOR DIODE 1SV305
D13	4815096H01	VARACTOR DIODE 1SV305
D170	4802482J02	PIN DIODE SMD
D171	4802482J02	PIN DIODE SMD
D172	4813978A26	DIODE ARRAY,DET,SOT-363/SC-88,30V,.
D173	4813978A26	DIODE ARRAY,DET,SOT-363/SC-88,30V,.
D20	4808115L27	DIODE ARRAY
D201	4815011H01	DIODE TRIPLE
D202	4815011H01	DIODE TRIPLE
D251	4813974A01	VARACTOR 3V DUAL
D252	4813974A01	VARACTOR 3V DUAL
D270	4813974A01	VARACTOR 3V DUAL

ITEM	MOTOROLA PART NUMBER	DESCRIPTION
D3	4815096H01	VARACTOR DIODE 1SV305
D4	4815096H01	VARACTOR DIODE 1SV305
D401	4805656W87	DIODE,VCTR, @ 15V,1SV279,SOD-523/S
D402	4805656W41	DIODE VARACTOR 40PF@1V 15PF@3V
D5	4815096H01	VARACTOR DIODE 1SV305
D500	4815155H01	RECTIFIER
D501	4809118D02	LED BICOLOR LNJ115W8POMT
D510	4813978M15	DIODE,RECT,RM140,SM,1A,40V,S HTK,PB-
D511	4813978B18	DIODE,SWG,BAT54,SM,SOT-23,200MA,30V
D512	4813978M15	DIODE,RECT,RM140,SM,1A,40V,S HTK,PB-
D513	4813978M15	DIODE,RECT,RM140,SM,1A,40V,S HTK,PB-
D6	4815096H01	VARACTOR DIODE 1SV305
D600	4813978B18	DIODE,SWG,BAT54,SM,SOT-23,200MA,30V
D603	4813978A25	DIODE, SCHOTTKY 30V SOD-323 T&R
D662	4813978A25	DIODE, SCHOTTKY 30V SOD-323 T&R
D700	4813978B18	DIODE,SWG,BAT54,SM,SOT-23,200MA,30V
E102	2480574F01	CHIP INDUC-TOR,BEAD,25%,200MA,FERR,S
E140	2405688Z01	INDUCTOR FERRITE BEAD
E141	2480574F01	CHIP INDUC-TOR,BEAD,25%,200MA,FERR,S
E402	2480640Z01	SURFACE MOUNT FERRITE BEAD
E406	2414032B76	IDCTR,WW,4.7UH,5%,330MA,4OH M,CER,20
E800	2480574F01	CHIP INDUC-TOR,BEAD,25%,200MA,FERR,S
E801	2480574F01	CHIP INDUC-TOR,BEAD,25%,200MA,FERR,S
E802	0613952G67	CER CHIP RES 0.0 +/-0.050 OHM

ITEM	MOTOROLA PART NUMBER	DESCRIPTION
F500	6515076H01	FUSE CHIP SMT TR/1608FF 3A
FL200	9116848H01	FLTR SW CAP 3 POLE BUTTERW
FL51	9185367C01	XTAL FLTR 5X7 SURFACE MT MONO
J101	2880658Z08	CONNECTOR, SMA
J601	0916287H01	CONN VERT 45 PIN ZIF
J650	0916287H02	CONN 20 PIN ZIF
L101	2414017N10	IND CER CHIP 6.8 NH 5%
L106	2414032D30	IDCTR,WW,1UH,5%,320MA,2.8OH M,CER,28
L114	2414032B60	IDCTR,WW,390NH,5%,620MA,1.12 OHM,CER
L115	2460591B80	COIL AIR WOUND INDUC 19.61
L117	2414017N18	IND CER CHIP 33.0 NH 5%
L118	0613952G67	CER CHIP RES 0.0 +/-0.050 OHM
L119	2479990E01	COIL AIR WOUND/GREEN CLR 23.75
L12	2414032F24	IDCTR,WW,15NH,5%,600MA,.17O HM,CER,4
L120	NOTPLACED	
L121	NOTPLACED	
L125	2479990A02	AIR WND COIL/GREEN COLOR7.66NH
L126	2415428H01	IDCTR,1.65NH,10%,SM
L127	2479990E01	COIL AIR WOUND/GREEN CLR 23.75
L128	2414032D30	IDCTR,WW,1UH,5%,320MA,2.8OH M,CER,28
L170	2479990N01	AIR WND COIL/GREEN COLOR 43.67
L171	2479990N01	AIR WND COIL/GREEN COLOR 43.67
L172	2479990N01	AIR WND COIL/GREEN COLOR 43.67
L176	2479990N01	AIR WND COIL/GREEN COLOR 43.67
L20	2414032F38	IDCTR,WW,220NH,5%,400MA,.7O HM,CER,3

ITEM	MOTOROLA PART NUMBER	DESCRIPTION
L200	2414017Q47	IDCTR,FXD,1UH,10%,50MA,.45OHM,FERR,
L201	2414017Q20	IDCTR,FXD,2.2UH,20%,30MA,.65OHM,FER
L202	2414017Q20	IDCTR,FXD,2.2UH,20%,30MA,.65OHM,FER
L203	2414017Q20	IDCTR,FXD,2.2UH,20%,30MA,.65OHM,FER
L204	2414017Q20	IDCTR,FXD,2.2UH,20%,30MA,.65OHM,FER
L205	2414017Q47	IDCTR,FXD,1UH,10%,50MA,.45OHM,FERR,
L206	2414017Q20	IDCTR,FXD,2.2UH,20%,30MA,.65OHM,FER
L21	2414032F31	IDCTR,WW,56NH,5%,500MA,.34OHM,CER,4
L251	2414032D30	IDCTR,WW,1UH,5%,320MA,2.8OHM,CER,28
L252	2414032D30	IDCTR,WW,1UH,5%,320MA,2.8OHM,CER,28
L253	2460591C35	COIL AIR WOUND INDUC 18.08
L254	2460591C03	COIL AIR WOUND INDUC 11.87
L257	0613958T74	CER CHIP RES 0.0 OHM JMP 1206
L258	2414032D17	IDCTR,WW,150NH,5%,750MA,.31OHM,CER,
L259	2414032D30	IDCTR,WW,1UH,5%,320MA,2.8OHM,CER,28
L266	2414032D18	IDCTR,WW,180NH,5%,700MA,.43OHM,CER,
L270	2414032D30	IDCTR,WW,1UH,5%,320MA,2.8OHM,CER,28
L271	2414032D30	IDCTR,WW,1UH,5%,320MA,2.8OHM,CER,28
L272	2414032B48	IDCTR,WW,39NH,5%,1A,.15OHM,CER,5
L273	2414032B46	IDCTR,WW,27NH,5%,1A,.13OHM,CER,50Q,
L274	2414032D40	IDCTR,WW,33NH,5%,1A,.11OHM,CER,4
L28	2414032F26	IDCTR,WW,22NH,5%,500MA,.22OHM,CER,

ITEM	MOTOROLA PART NUMBER	DESCRIPTION
L31	2414032F34	IDCTR,WW,100NH,5%,400MA,.46OHM,CER
L34	2414032F35	IDCTR,WW,120NH,5%,400MA,.51OHM,CER,
L403	2414032B75	IDCTR,WW,3.9UH,5%,340MA,3.6OHM,CER,
L404	2414032B59	IDCTR,WW,330NH,5%,690MA,1.05OHM,CER
L407	2414032B76	IDCTR,WW,4.7UH,5%,330MA,4OHM,CER,20
L411	2466505A01	COIL INDUCTOR
L412	2466505A01	COIL INDUCTOR
L413	2414032B64	IDCTR,WW,680NH,5%,540MA,1.47OHM,CER
L414	2414017Q51	IDCTR,FXD,2.2UH,10%,30MA,.65OHM,FER
L42	2414032F24	IDCTR,WW,15NH,5%,600MA,.17OHM,CER,4
L45	2414032F27	IDCTR,FXD,27NH,5%,500MA,.25OHM,CER,
L47	2414032F33	IDCTR,WW,82NH,5%,400MA,.42OHM,CER,4
L48	2414032F27	IDCTR,FXD,27NH,5%,500MA,.25OHM,CER,
L49	2414032F24	IDCTR,WW,15NH,5%,600MA,.17OHM,CER,4
L5	2414032F24	IDCTR,WW,15NH,5%,600MA,.17OHM,CER,4
L500	2414017Q42	IDCTR,FXD,390NH,10%,200MA,.65OHM,FE
L501	2414017Q51	IDCTR,FXD,2.2UH,10%,30MA,.65OHM,FER
L502	2489669V01	CHIP IND 100000 NH 10%
L54	2414032F73	IDCTR,WW,820NH,5%,180MA,2.23OHM,CER
L55	0613958T74	CER CHIP RES 0.0 OHM JMP 1206
L56	2414032D25	IDCTR,WW,620NH,5%,400MA,1.6OHM,CER
L6	2414032F27	IDCTR,FXD,27NH,5%,500MA,.25OHM,CER,
L60	2414017G13	IDCTR,CHIP,33NH,5%,300MA,.65OHM,CER

ITEM	MOTOROLA PART NUMBER	DESCRIPTION
L61	2414017N16	IDCTR,CHIP,22NH,5%,600MA,.54OHM,CER
L62	2414017N16	IDCTR,CHIP,22NH,5%,600MA,.54OHM,CER
L63	2414017Q40	IDCTR,FXD,270NH,10%,250MA,.5OHM,FER
L64	NOTPLACED	
L651	2414032F75	IDCTR,CHIP,270NH,2%,350MA,1OHM,CER,
L652	2414032F75	IDCTR,CHIP,270NH,2%,350MA,1OHM,CER,
L7	2414032F33	IDCTR,WW,82NH,5%,400MA,.42OHM,CER,4
L701	2486085A01	IDCTR,22UH,20%,SHLD
L702	2486085A01	IDCTR,22UH,20%,SHLD
L703	2464675H01	IDCTR,WW,560NH,5%,550MA
L704	2464675H01	IDCTR,WW,560NH,5%,550MA
L705	2464675H01	IDCTR,WW,560NH,5%,550MA
L708	2416307H01	IDCTR,WW,680NH,5%,0603
L710	2416307H01	IDCTR,WW,680NH,5%,0603
L8	2414032F27	IDCTR,FXD,27NH,5%,500MA,.25OHM,CER,
M701	0985888K02	SKT RTC BTTY LEAP
P100	3916333H02	CONTACT ANT GRD
P4	3905643V01	CONTACT ANT GRD
Q101	4816698H02	MITSUBISHI,FET RF POWER,VHF
Q197	4813973A13	XSTR,BIP GP SS,PNP,T3906,SM,SOT-23,
Q200	4871674S01	TSTR SOT BCW 60B (RH)
Q29	4805585Q28	TRANSISTOR RF NPN 8GHZ NOPB
Q301	4816371H01	XSTR DUAL PNP W18 COMPLIANT
Q401	4805585Q28	TRANSISTOR RF NPN 8GHZ NOPB
Q402	4813973A04	XSTR NPN 30V DARLINGTON
Q501	4805921T28	XSTR, DUAL NOPB

ITEM	MOTOROLA PART NUMBER	DESCRIPTION
Q698	4813973A81	XSTR,BIP GP SS,DIG,NPN AND PNP,SOT
Q700	4813970A62	XSTR,FET GP PWR,MOSFET,P-CH,ENHN,C
Q701	4813973M07	XSTR,BIP GP SS,NPN,T3904,SM,SOT-23,
Q702	5185956E76	IC,CONV,SM,SO16,0-30 VINPUT RANGE
Q703	4813970A62	XSTR,FET GP PWR,MOSFET,P-CH,ENHN,C
Q704	NOTPLACED	
Q705	NOTPLACED	
Q706	NOTPLACED	
Q709	4885061Y01	XSTR NPN 6V 30UA 12GHZ PB-FREE
Q801	4813973A42	XSTR,BIP GP SS,NPN,SM,SC-59,SMT,50V
Q804	4813973A81	XSTR,BIP GP SS,DIG,NPN AND PNP,SOT
R102	0613952G67	CER CHIP RES 0.0 +/-0.050 OHM
R103	0613952Q73	CER CHIP RES 1000 OHM 5% 0402
R104	0613952J15	CER CHIP RES 39K OHM 5% 0603
R105	NOTPLACED	
R108	0613952G67	CER CHIP RES 0.0 +/-0.050 OHM
R109	0613952R66	CER CHIP RES 0.0 +/-0.050 OHM
R115	0613958H57	CER CHIP RES 220 OHM 5% 0805
R125	0613952H47	CER CHIP RES 82.0 OHM 5% 0603
R127	0613952R01	CER CHIP RES 10K OHM 5% 0402
R13	0613952R01	CER CHIP RES 10K OHM 5% 0402
R14	0613952R01	CER CHIP RES 10K OHM 5% 0402
R142	0613952Z55	RES,MF,12KOHM,1%,.0625W,SM,0402,200
R143	0613952Z65	RES,MF,43KOHM,1%,.0625W,SM,0402,200
R144	0613952R25	CER CHIP RES 100K OHM 5% 0402
R146	0613952H73	CER CHIP RES 1000 OHM 5% 0603

ITEM	MOTOROLA PART NUMBER	DESCRIPTION
R149	0613952Q89	CER CHIP RES 4700 OHM 5% 0402
R15	NOTPLACED	
R150	0613952H47	CER CHIP RES 82.0 OHM 5% 0603
R151	0613952H47	CER CHIP RES 82.0 OHM 5% 0603
R153	NOTPLACED	
R154	0613952R66	CER CHIP RES 0.0 +/-0.050 OHM
R155	0613952Q77	CER CHIP RES 1500 OHM 5% 0402
R156	NOTPLACED	
R157	0613952Q71	CER CHIP RES 820 OHM 5% 0402
R158	0613952Q49	CER CHIP RES 100 OHM 5% 0402
R159	0613952R66	CER CHIP RES 0.0 +/-0.050 OHM
R160	0613952R66	CER CHIP RES 0.0 +/-0.050 OHM
R161	0613952R66	CER CHIP RES 0.0 +/-0.050 OHM
R162	NOTPLACED	
R168	0613952Q49	CER CHIP RES 100 OHM 5% 0402
R169	0613952Q49	CER CHIP RES 100 OHM 5% 0402
R199	0613952J01	CER CHIP RES 10K OHM 5% 0603
R201	0613952Q47	CER CHIP RES 82.0 OHM 5% 0402
R202	0613952Q69	CER CHIP RES 680 OHM 5% 0402
R203	0613952Q57	CER CHIP RES 220 OHM 5% 0402
R204	0613952R19	CER CHIP RES 56K OHM 5% 0402
R205	0613952R15	CER CHIP RES 39K OHM 5% 0402
R206	0613952R01	CER CHIP RES 10K OHM 5% 0402
R207	0613952Q73	CER CHIP RES 1000 OHM 5% 0402
R208	0613952R13	CER CHIP RES 33K OHM 5% 0402
R209	0613952G67	CER CHIP RES 0.0 +/-0.050 OHM
R210	0613952R13	CER CHIP RES 33K OHM 5% 0402
R211	0613952Q80	CER CHIP RES 2000 OHM 5% 0402
R212	NOTPLACED	
R213	0613952Q95	CER CHIP RES 8200 OHM 5% 0402

ITEM	MOTOROLA PART NUMBER	DESCRIPTION
R214	0613952Q73	CER CHIP RES 1000 OHM 5% 0402
R215	0613952R01	CER CHIP RES 10K OHM 5% 0402
R216	0613952Q49 (PMLD4303A) 0613952K93 (PMLD4303D)	CER CHIP RES 100 OHM 5% 0402 CER CHIP RES 91 OHM 5% 0402
R22	0613952Q25	CER CHIP RES 10.0 OHM 5% 0402
R23	0613952R31	CER CHIP RES 180K OHM 5% 0402
R24	0613952R31	CER CHIP RES 180K OHM 5% 0402
R251	0613952R66	CER CHIP RES 0.0 +/-0.050 OHM
R252	0613952Q36	CER CHIP RES 30.0 OHM 5% 0402
R253	0613952Q61	CER CHIP RES 330 OHM 5% 0402
R254	0613952R35	CER CHIP RES 270K OHM 5% 0402
R255	0613952Q73	CER CHIP RES 1000 OHM 5% 0402
R257	0613952R01	CER CHIP RES 10K OHM 5% 0402
R26	0613952Q83	CER CHIP RES 2700 OHM 5% 0402
R266	0613952Q61	CER CHIP RES 330 OHM 5% 0402
R270	0613952Q38	CER CHIP RES 36.0 OHM 5% 0402
R271	0613952Q59	CER CHIP RES 270 OHM 5% 0402
R272	0613952Q56	CER CHIP RES 200 OHM 5% 0402
R273	0613952Q65	CER CHIP RES 470 OHM 5% 0402
R274	0613952Q29	CER CHIP RES 15.0 OHM 5% 0402
R275	0613952Q65	CER CHIP RES 470 OHM 5% 0402
R277	0613952R01	CER CHIP RES 10K OHM 5% 0402
R291	0613952Q37	CER CHIP RES 33.0 OHM 5% 0402
R293	0613952Q37	CER CHIP RES 33.0 OHM 5% 0402
R294	0613952Q61	CER CHIP RES 330 OHM 5% 0402
R295	0613952R01	CER CHIP RES 10K OHM 5% 0402
R30	0613952Q25	CER CHIP RES 10.0 OHM 5% 0402
R32	0613952H33	CER CHIP RES 22.0 OHM 5% 0603
R33	0613952R01	CER CHIP RES 10K OHM 5% 0402

ITEM	MOTOROLA PART NUMBER	DESCRIPTION
R34	0613952R01	CER CHIP RES 10K OHM 5% 0402
R406	0613952R01	CER CHIP RES 10K OHM 5% 0402
R407	0613952R01	CER CHIP RES 10K OHM 5% 0402
R408	0613952H79	CER CHIP RES 1800 OHM 5% 0603
R412	0613952H62	CER CHIP RES 360 OHM 5% 0603
R413	0613952H68	CER CHIP RES 620 OHM 5% 0603
R414	0613952R07	CER CHIP RES 18K OHM 5% 0402
R415	0613952R03	CER CHIP RES 12K OHM 5% 0402
R417	0613952Q74	RES,MF,1.1KOHM,5%,.0625W,SM,0402,20
R418	0613952R66	CER CHIP RES 0.0 +/-0.050 OHM
R419	0613952R25	CER CHIP RES 100K OHM 5% 0403
R420	0613952R19	CER CHIP RES 56K OHM 5% 0402
R436	0613952R66	CER CHIP RES 0.0 +/-0.050 OHM
R499	0613952R01	CER CHIP RES 10K OHM 5% 0402
R503	0613952Q63	CER CHIP RES 390 OHM 5% 0402
R504	0613952Q66	CER CHIP RES 510 OHM 5% 0402
R505	0613952R01 (PMLD4303A) 0613952Q93 (PMLD4303D)	CER CHIP RES 10K OHM 5% 0402 CER CHIP RES 6.8K OHM 5% 0402
R507	0613952Q49	CER CHIP RES 100 OHM 5% 0402
R508	0613952Q49	CER CHIP RES 100 OHM 5% 0402
R509	0613952Q49	CER CHIP RES 100 OHM 5% 0402
R510	0613952Q49	CER CHIP RES 100 OHM 5% 0402
R511	0613952R01	CER CHIP RES 10K OHM 5% 0402
R512	0613952R17	CER CHIP RES 47K OHM 5% 0402
R513	0613952R01	CER CHIP RES 10K OHM 5% 0402
R514	0613952R01	CER CHIP RES 10K OHM 5% 0402
R515	0613952R01	CER CHIP RES 10K OHM 5% 0402
R516	0613952R01	CER CHIP RES 10K OHM 5% 0402
R517	0613952R01	CER CHIP RES 10K OHM 5% 0402
R518	0613952R01	CER CHIP RES 10K OHM 5% 0402

ITEM	MOTOROLA PART NUMBER	DESCRIPTION
R519	0613952R17	CER CHIP RES 47K OHM 5% 0402
R520	0613952R37	CER CHIP RES 330K OHM 5% 0402
R521	NOTPLACED	
R522	0613952R17	CER CHIP RES 47K OHM 5% 0402
R523	0613952R17	CER CHIP RES 47K OHM 5% 0402
R524	0613952G67	CER CHIP RES 0.0 +/-0.050 OHM
R525	0613952R01	CER CHIP RES 10K OHM 5% 0402
R526	0613952R01	CER CHIP RES 10K OHM 5% 0402
R527	0613952G67	CER CHIP RES 0.0 +/-0.050 OHM
R528	NOTPLACED	
R60	0613952Q49	CER CHIP RES 100 OHM 5% 0402
R608	0613952Q49	CER CHIP RES 100 OHM 5% 0402
R610	NOTPLACED	
R611	0613952Q49	CER CHIP RES 100 OHM 5% 0402
R613	0613952R08	CER CHIP RES 20K OHM 5% 0402
R614	0613952R08	CER CHIP RES 20K OHM 5% 0402
R615	0613952R25	CER CHIP RES 100K OHM 5% 0404
R616	0613952Q49	CER CHIP RES 100 OHM 5% 0402
R617	NOTPLACED	
R620	0613952Q49	CER CHIP RES 100 OHM 5% 0402
R621	0613952Q49	CER CHIP RES 100 OHM 5% 0402
R622	0613952Q49	CER CHIP RES 100 OHM 5% 0402
R625	0613952Q49	CER CHIP RES 100 OHM 5% 0402
R626	0613952Q49	CER CHIP RES 100 OHM 5% 0402
R633	NOTPLACED	
R634	0613952R66	CER CHIP RES 0.0 +/-0.050 OHM
R635	NOTPLACED	
R636	0613952R01	CER CHIP RES 10K OHM 5% 0402
R637	0613952Q49	CER CHIP RES 100 OHM 5% 0402
R638	0613952Q49	CER CHIP RES 100 OHM 5% 0402
R639	0613952Q49	CER CHIP RES 100 OHM 5% 0402
R640	0613952Q49	CER CHIP RES 100 OHM 5% 0402

ITEM	MOTOROLA PART NUMBER	DESCRIPTION
R641	0613952Q49	CER CHIP RES 100 OHM 5% 0402
R642	0613952Q49	CER CHIP RES 100 OHM 5% 0402
R643	0613952Q49	CER CHIP RES 100 OHM 5% 0402
R644	0613952Q49	CER CHIP RES 100 OHM 5% 0402
R647	0613952R01	CER CHIP RES 10K OHM 5% 0402
R649	0613952R17	CER CHIP RES 47K OHM 5% 0402
R654	0613952R01	CER CHIP RES 10K OHM 5% 0402
R656	0613952R01	CER CHIP RES 10K OHM 5% 0402
R658	0613952P18	CER CHIP RES 150K OHM 1% 0402
R666	0613952Q42	CER CHIP RES 51.0 OHM 5% 0402
R667	0613952Q63	CER CHIP RES 390 OHM 5% 0402
R668	0613952Q45	CER CHIP RES 68.0 OHM 5% 0402
R669	0613952Q49	CER CHIP RES 100 OHM 5% 0402
R670	0613952Q49	CER CHIP RES 100 OHM 5% 0402
R671	0613952Q63	CER CHIP RES 390 OHM 5% 0402
R672	0613952R01	CER CHIP RES 10K OHM 5% 0402
R673	0613952R01	CER CHIP RES 10K OHM 5% 0402
R674	0613952Q49	CER CHIP RES 100 OHM 5% 0402
R675	0613952Q67	CER CHIP RES 560 OHM 5% 0402
R677	0613952R01	CER CHIP RES 10K OHM 5% 0402
R678	0613952Q49	CER CHIP RES 100 OHM 5% 0402
R697	0613952Q49	CER CHIP RES 100 OHM 5% 0402
R700	0613952Q80	CER CHIP RES 2000 OHM 5% 0402
R701	0613952R17	CER CHIP RES 47K OHM 5% 0402
R702	0613952R66	CER CHIP RES 0.0 +/-0.050 OHM
R703	0613952R17	CER CHIP RES 47K OHM 5% 0402
R704	0613952Q49	CER CHIP RES 100 OHM 5% 0402
R705	0613952R17	CER CHIP RES 47K OHM 5% 0402
R708	0613952R19	CER CHIP RES 56K OHM 5% 0402
R709	0613952H17	CER CHIP RES 4.7OHM 5%
R710	0689057L02	RES WSL0805 .1 OHM 1% 2X1.27MM

ITEM	MOTOROLA PART NUMBER	DESCRIPTION
R711	0613952G67	CER CHIP RES 0.0 +/-0.050 OHM
R712	0613952Q49	CER CHIP RES 100 OHM 5% 0402
R714	0689057L02	RES WSL0805 .1 OHM 1% 2X1.27MM
R717	0613952R66	CER CHIP RES 0.0 +/-0.050 OHM
R718	0613952G67	CER CHIP RES 0.0 +/-0.050 OHM
R722	0613952R08	CER CHIP RES 20K OHM 5% 0402
R725	0613952R66	CER CHIP RES 0.0 +/-0.050 OHM
R726	0613952R66	CER CHIP RES 0.0 +/-0.050 OHM
R729	0613952R13	CER CHIP RES 33K OHM 5% 0402
R740	0613952Q63	CER CHIP RES 390 OHM 5% 0402
R741	0613952R17	CER CHIP RES 47K OHM 5% 0402
R742	0613952R17	CER CHIP RES 47K OHM 5% 0402
R743	NOTPLACED	
R744	NOTPLACED	
R745	0613952R56	CER CHIP RES 2.0M OHM 5% 0402
R746	0613952R56	CER CHIP RES 2.0M OHM 5% 0402
R747	0613952Q73	CER CHIP RES 1000 OHM 5% 0402
R748	0613952R41	CER CHIP RES 470K OHM 5% 0402
R749	0613952R41	CER CHIP RES 470K OHM 5% 0402
R750	0613952Q63	CER CHIP RES 390 OHM 5% 0402
R751	0613952Q63	CER CHIP RES 390 OHM 5% 0402
R752	0613952Q81	CER CHIP RES 2200 OHM 5% 0402
R753	0613952Q81	CER CHIP RES 2200 OHM 5% 0402
R756	0613952R66	CER CHIP RES 0.0 +/-0.050 OHM
R757	0613952R08	CER CHIP RES 20K OHM 5% 0402
R758	0613952R19	CER CHIP RES 56K OHM 5% 0402
R759	0613952R01	CER CHIP RES 10K OHM 5% 0402
R760	0613952Q93	CER CHIP RES 6800 OHM 5% 0402

ITEM	MOTOROLA PART NUMBER	DESCRIPTION
R763	NOTPLACED	
R764	NOTPLACED	
R765	NOTPLACED	
R767	0613952R66	CER CHIP RES 0.0 +/-0.050 OHM
R768	NOTPLACED	
R771	NOTPLACED	
R772	0613952Q49	CER CHIP RES 100 OHM 5% 0402
R773	0613952Q49	CER CHIP RES 100 OHM 5% 0402
R774	0613952Q49	CER CHIP RES 100 OHM 5% 0402
R775	0613952Q49	CER CHIP RES 100 OHM 5% 0402
R776	NOTPLACED	
R777	0613952R01	CER CHIP RES 10K OHM 5% 0402
R778	0613952R01	CER CHIP RES 10K OHM 5% 0402
R779	0613952R01	CER CHIP RES 10K OHM 5% 0402
R780	0613952Q89	CER CHIP RES 4700 OHM 5% 0402
R781	0613952R01	CER CHIP RES 10K OHM 5% 0402
R782	0613952R01	CER CHIP RES 10K OHM 5% 0402
R783	0613952R01	CER CHIP RES 10K OHM 5% 0402
R784	NOTPLACED	
R785	0613952Q49	CER CHIP RES 100 OHM 5% 0402
R786	0613952R17	CER CHIP RES 47K OHM 5% 0402
R790	0613952R19	CER CHIP RES 56K OHM 5% 0402
R791	0613952R66	CER CHIP RES 0.0 +/-0.050 OHM
R792	0613952R66	CER CHIP RES 0.0 +/-0.050 OHM
R793	0613952R66	CER CHIP RES 0.0 +/-0.050 OHM
R794	0613952R66	CER CHIP RES 0.0 +/-0.050 OHM
R795	0613952R17	CER CHIP RES 47K OHM 5% 0402
R796	0613952R66	CER CHIP RES 0.0 +/-0.050 OHM
R797	0613952Q41	CER CHIP RES 47.0 OHM 5% 0402
R798	0613952Q61	CER CHIP RES 330 OHM 5% 0402
R799	0613952R01	CER CHIP RES 10K OHM 5% 0402
R801	NOTPLACED	
R802	0613952Q49	CER CHIP RES 100 OHM 5% 0402

ITEM	MOTOROLA PART NUMBER	DESCRIPTION
R803	0613952Q49	CER CHIP RES 100 OHM 5% 0402
R804	0613952Q66	CER CHIP RES 510 OHM 5% 0402
R805	0613952R01	CER CHIP RES 10K OHM 5% 0402
R806	0613952Q66	CER CHIP RES 510 OHM 5% 0402
R807	0613952R01	CER CHIP RES 10K OHM 5% 0402
R808	0613952R66	CER CHIP RES 0.0 +/-0.050 OHM
R809	0613952R17	CER CHIP RES 47K OHM 5% 0402
R810	0613952R01	CER CHIP RES 10K OHM 5% 0402
R811	0613952Q66	CER CHIP RES 510 OHM 5% 0402
R812	0613952R25	CER CHIP RES 100K OHM 5% 0405
R813	0613952R66	CER CHIP RES 0.0 +/-0.050 OHM
R814	NOTPLACED	
R815	0613952R66	CER CHIP RES 0.0 +/-0.050 OHM
R816	0613952R17	CER CHIP RES 47K OHM 5% 0402
R820	0613952R01	CER CHIP RES 10K OHM 5% 0402
R829	NOTPLACED	
R837	0613952Q37	CER CHIP RES 33.0 OHM 5% 0402
R838	0613952Q37	CER CHIP RES 33.0 OHM 5% 0402
R839	0613952R01	CER CHIP RES 10K OHM 5% 0402
R840	0613952Q66	CER CHIP RES 510 OHM 5% 0402
R841	0613952R01	CER CHIP RES 10K OHM 5% 0402
R842	0613952R01	CER CHIP RES 10K OHM 5% 0402
R843	0613952R41	CER CHIP RES 470K OHM 5% 0402
R844	0613952Q61	CER CHIP RES 330 OHM 5% 0402
S500	4085131E02	SWITCH FREQ DUAL FUNCTION
S501	1880619Z04	POTENTIOMETER (VOLUME)
S502	4016618H01	SWITCH TACTILE
S503	4070354A01	SW,SM,SPST,PUSH-ON,50MA,12V,REFLOWA
S504	4070354A01	SW,SM,SPST,PUSH-ON,50MA,12V,REFLOWA
S505	4070354A01	SW,SM,SPST,PUSH-ON,50MA,12V,REFLOWA

ITEM	MOTOROLA PART NUMBER	DESCRIPTION
S506	4070354A01	SW,SM,SPST,PUSH-ON,50MA,12V,REFLOWA
SH1	2686707Z02	SHIELD, SM SLDRD,CRS,PLTD
SH101	2686702Z02	SHIELD, SM SLDRD,CRS,PLTD
SH102	2686701Z02	SHIELD, SM SLDRD,CRS,PLTD
SH103	2686708Z02	SHIELD, SM SLDRD,CRS,PLTD
SH201	2686705Z02	SHIELD, SM SLDRD,CRS,PLTD
SH251	2616554H01	SHLD VCO TOP
SH252	2616559H01	SHLD PCIC
SH401	2686706Z02	SHIELD, SM SLDRD,CRS,PLTD
SH402	2686698Z02	SHIELD, SM SLDRD,CRS,PLTD
SH51	2686700Z02	SHIELD, SM SLDRD,CRS,PLTD
SH52	2686699Z02	SHIELD, SM SLDRD,CRS,PLTD
T51	2515121H01	BALUN, TRANSFORMER W18 COMP
T53	2516320H01	XFMR SMALL SIGNAL SURFACE MT
U1	5164015H81	IC,MXR,DBL BAL GILBERT,CELL,SM
U101	5115678H01	VHF/UHF/800/900 MHZ LDMOS DRIVER IC
U102	5185765B26	IC PWR CTRL IN MOS20
U103	5115022H01	IC TEMPERATURE SENSOR
U2	5185941F45	ATTEN,VAR,14.4DBMIN,15.6DBMAX,0-200
U201	5185941F40	IC, 12 BIT DAC
U202	5116245H01	CC LVFRACN
U250	5105750U56	IC PKG DIE VCO BUFFER
U3	5185143E12	DUAL INVERTER IC
U401	5185963A85	IC-ABACUS III-LP
U500	5188493T01	IC,IC MINI SO-8 HI PRCN REG
U501	5185941F35	IC, VREG, NOPB
U502	5185941F35	IC, VREG, NOPB
U601	5185941F22	IC,OPAMP,SGL,OPA237,SOT23,N OPB
U602	5185941F22	IC,OPAMP,SGL,OPA237,SOT23,N OPB

ITEM	MOTOROLA PART NUMBER	DESCRIPTION
U701	5185143E77	IC, MAKO ASIC, CMOS PWR MGMT
U702	5185941F22	IC,OPAMP,SGL,OPA237,SOT23,N OPB
U705	5114000B39	IC,BFR,1PER PKG,SM,SOT-353,PB-FR
U712	5188691V01	IC,MUX/DEMUX,NC7SB3157P6X,SM,SC70
U713	5115453H01	RAIL TO RAIL OUTPUT, 8 PIN BGA
U714	5115453H01	RAIL TO RAIL OUTPUT, 8 PIN BGA
U800	5185941F04	IC, PATRIOT BRAVO, 1.2.2,256BGA, PB
U801	5114000B39	IC,BFR,1PER PKG,SM,SOT-353,PB-FR
U802	5114000B39	IC,BFR,1PER PKG,SM,SOT-353,PB-FR
U803	5185956E69	IC,DRAM,
U804	5185941F03	IC,SRAM,
U805	5116411H01	IC,OP AMP,
VR500	4809788E21	DIODE,ZEN,MM3Z6V8ST1G,SM,S OD-323,6.
VR501	4813977M19	DIODE,ZEN,SOT-23,10V,.225W,PB-
VR502	4809788E21	DIODE,ZEN,MM3Z6V8ST1G,SM,S OD-323,6.
VR503	4809788E21	DIODE,ZEN,MM3Z6V8ST1G,SM,S OD-323,6.
VR504	4809788E21	DIODE,ZEN,MM3Z6V8ST1G,SM,S OD-323,6.
VR505	4809788E21	DIODE,ZEN,MM3Z6V8ST1G,SM,S OD-323,6.
VR506	4809788E21	DIODE,ZEN,MM3Z6V8ST1G,SM,S OD-323,6.
VR508	4813977A43	DIODE ARRAY,SUPR,SM,SOT-23,3V,24W,Z
VR509	4813977A43	DIODE ARRAY,SUPR,SM,SOT-23,3V,24W,Z
VR510	4813977A43	DIODE ARRAY,SUPR,SM,SOT-23,3V,24W,Z
VR511	4813977A43	DIODE ARRAY,SUPR,SM,SOT-23,3V,24W,Z

ITEM	MOTOROLA PART NUMBER	DESCRIPTION
VR512	4813977A43	DIODE ARRAY,SUPR,SM,SOT-23,3V,24W,Z
VR513	4813977A43	DIODE ARRAY,SUPR,SM,SOT-23,3V,24W,Z
VR514	4809788E21	DIODE,ZEN,MM3Z6V8ST1G,SM,S OD-323,6.
VR650	4813979P12	DIODE ARRAY,TRANSIENT PROTECTION,SM
VR651	4813977A43	DIODE ARRAY,SUPR,SM,SOT-23,3V,24W,Z
VR652	4813977A43	DIODE ARRAY,SUPR,SM,SOT-23,3V,24W,Z
VR657	4809788E21	DIODE,ZEN,MM3Z6V8ST1G,SM,S OD-323,6.
VR658	4813977C23	DIODE,ZEN,MMSZ5243,SM,SOD-123,13V,1
VR659	4813979P10	TRANS SUP 5.6V QUAD
VR662	4813979P10	TRANS SUP 5.6V QUAD
VR663	4813977M18	DIODE,ZEN,SOT-23,9.1V,.225W,PB
VR678	4866544A01	DIODE ARRAY,ZEN,SR05.TCT,SM,5V,
VR701	4813977M11	DIODE,ZEN,MBZ5232,SM,SOT-23,5.6V,10
Y200	4802245J68	OSC, REF 16.8 MHZ 1.5 PPM
Y701	4809995L05	RESON,QRTZ,.032768MHZ,SM,FUND,
Y702	4864005H01	RESONATOR, CRYSTAL 24.576 MHZ
	5686357Z01	CHASSIS ANTISTATIC CLAMSHELL, STINGRE
	6003710K08	BAT,LI,3.3V,3MAH,COIN-CELL,RECHARGA
	8416494H02	PCB

Notes:

- For optimum performance, order replacement diodes, transistors, and circuit modules by Motorola part number only.
- When ordering crystals, specify carrier frequency, crystal frequency, crystal type number, and Motorola part number.
- Part value notations:
 $p=10^{-12}$
 $n=10^{-9}$
 $\mu=10^{-6}$
 $m=10^{-3}$
 $k=10^3$
 $M=10^6$
- ITEM refers to the component reference designator. SIDE refers to the location of the component on the board; S1=Side 1, S2=Side 2.
- The PMLD4303A RF Board uses a 6-layer printed circuit board.

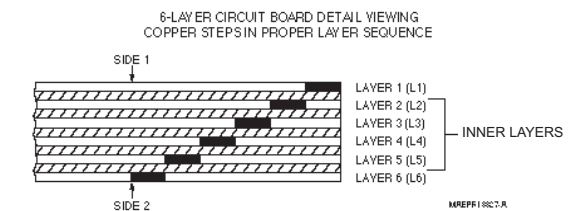

Chapter 9.2 UHF1 Schematics, Board Overlays, and Parts Lists

9.2.1 Introduction

This chapter contains the schematics, board layouts, and parts lists for the XTS 2500/2500I/2250/1500 radios. Use them in conjunction with the theory of operation and the troubleshooting procedures, charts, and waveforms to isolate a problem to the component level.

Table 9.2-1. UHF1 Schematics, Board Overlays and Parts Lists

Schematic/Board Layout	Page No.
Radio Interconnect Block Diagram	9.2-2
PMLE2537A/ PMLE2537D Top Level Schematic	9.2-3
PMLE2537A/ PMLE2537D Controller Interface Schematic	9.2-4
PMLE2537A/ PMLE2537D Controller Schematic	9.2-5
PMLE2537A/ PMLE2537D Memory Schematic	9.2-6
PMLE2537A/ PMLE2537D Patriot Bravo (U800) Schematic	9.2-7
PMLE2537A/ PMLE2537D MAKO DC and Audio Schematic - Sheet 1 of 2	9.2-8
PMLE2537A/ PMLE2537D MAKO DC and Audio Schematic - Sheet 2 of 2	9.2-9
PMLE2537A/ PMLE2537D Interface and Accessories Schematic	9.2-10
PMLE2537A/ PMLE2537D Side Connector Schematic	9.2-11
PMLE2537A/ PMLE2537D RF Schematic	9.2-12
PMLE2537A/ PMLE2537D Receiver Front End and DC Schematic	9.2-13
PMLE2537A/ PMLE2537D Receiver Front End Schematic	9.2-14
PMLE2537A/ PMLE2537D Receiver Schematic - Sheet 1 of 4	9.2-15
PMLE2537A/ PMLE2537D Receiver Schematic - Sheet 2 of 4	9.2-16
PMLE2537A/ PMLE2537D Receiver Schematic - Sheet 3 of 4	9.2-17
PMLE2537A/ PMLE2537D Receiver Schematic, Regulators - Sheet 4 of 4	9.2-18
PMLE2537A/ PMLE2537D Frequency Generation Unit (FGU) and Digital to Analog Converter (DAC) Schematic	9.2-19
PMLE2537A Frequency Generation Unit (FGU) Schematic - Sheet 1 of 4	9.2-20
PMLE2537D Frequency Generation Unit (FGU) Schematic - Sheet 1 of 4	9.2-21
PMLE2537A/ PMLE2537D Frequency Generation Unit (FGU) Schematic - Sheet 2 of 4	9.2-22
PMLE2537A/ PMLE2537D Frequency Generation Unit (FGU) Schematic - Sheet 3 of 4	9.2-23
PMLE2537A/ PMLE2537D Frequency Generation Unit (FGU) Schematic - Sheet 4 of 4	9.2-24
PMLE2537A RF Controls Schematic	9.2-25
PMLE2537D RF Controls Schematic	9.2-26
PMLE2537A/ PMLE2537D Transmitter Schematic	9.2-27
PMLE2537A/ PMLE2537D Main Circuit Board Component Location Detail - Top Side	9.2-28
PMLE2537A/ PMLE2537D Main Circuit Board Component Location Detail - Bottom Side	9.2-29
PMLE2537A/ PMLE2537D Main Circuit Board Electrical Parts List	9.2-30

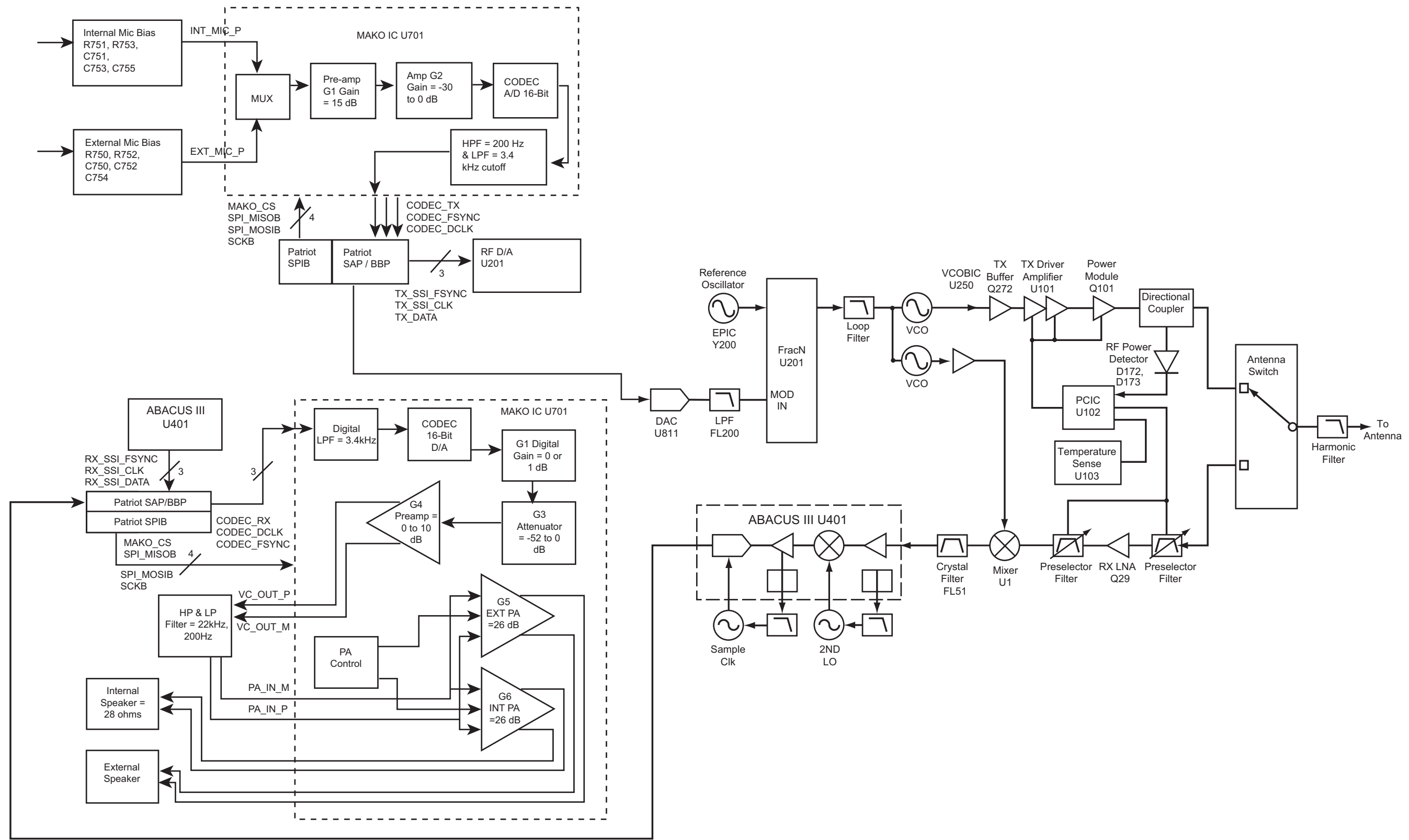

Figure 9.2-1. Radio Interconnect Block Diagram

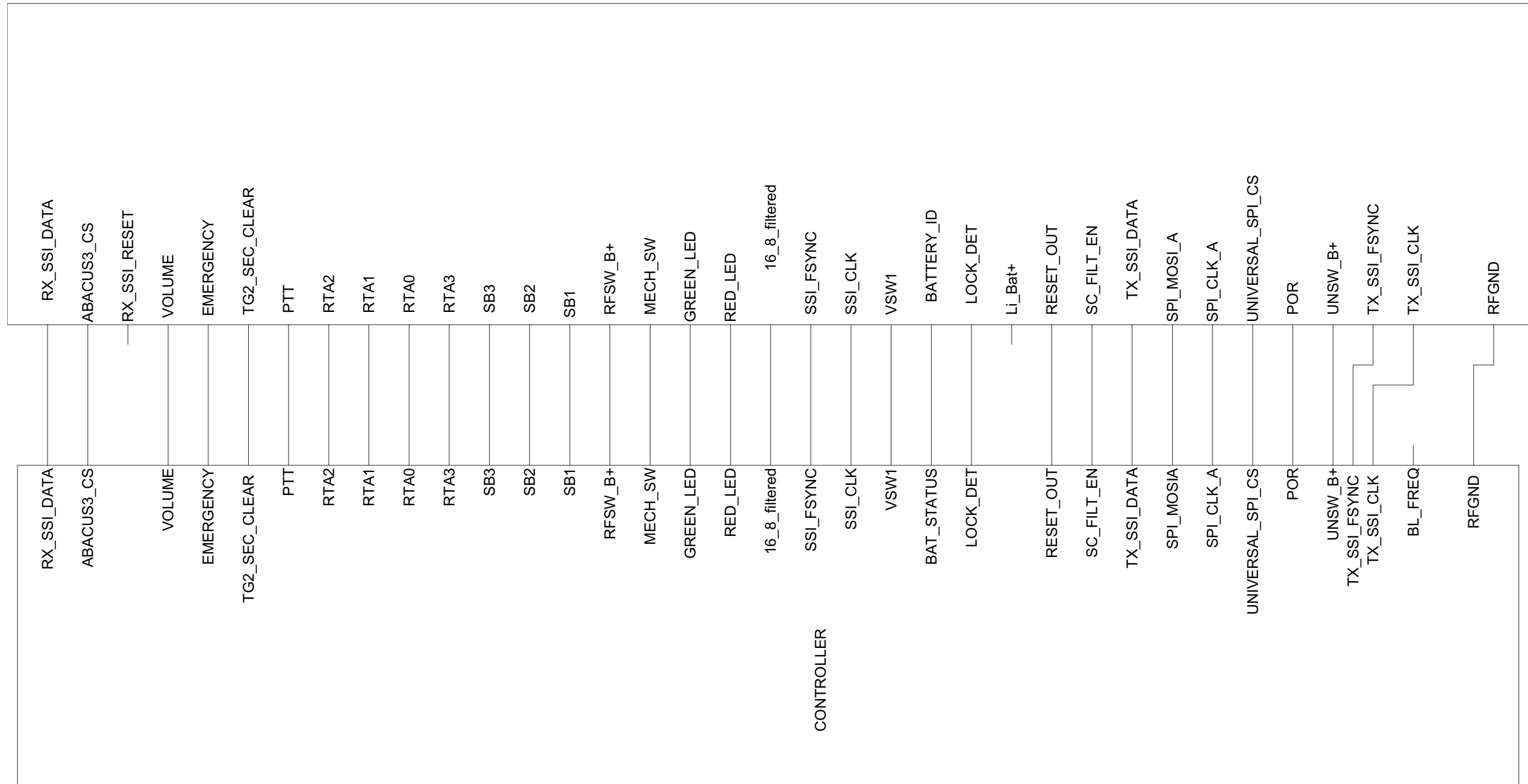

Figure 9.2-2. PMLE2537A/ PMLE2537D Top Level Schematic

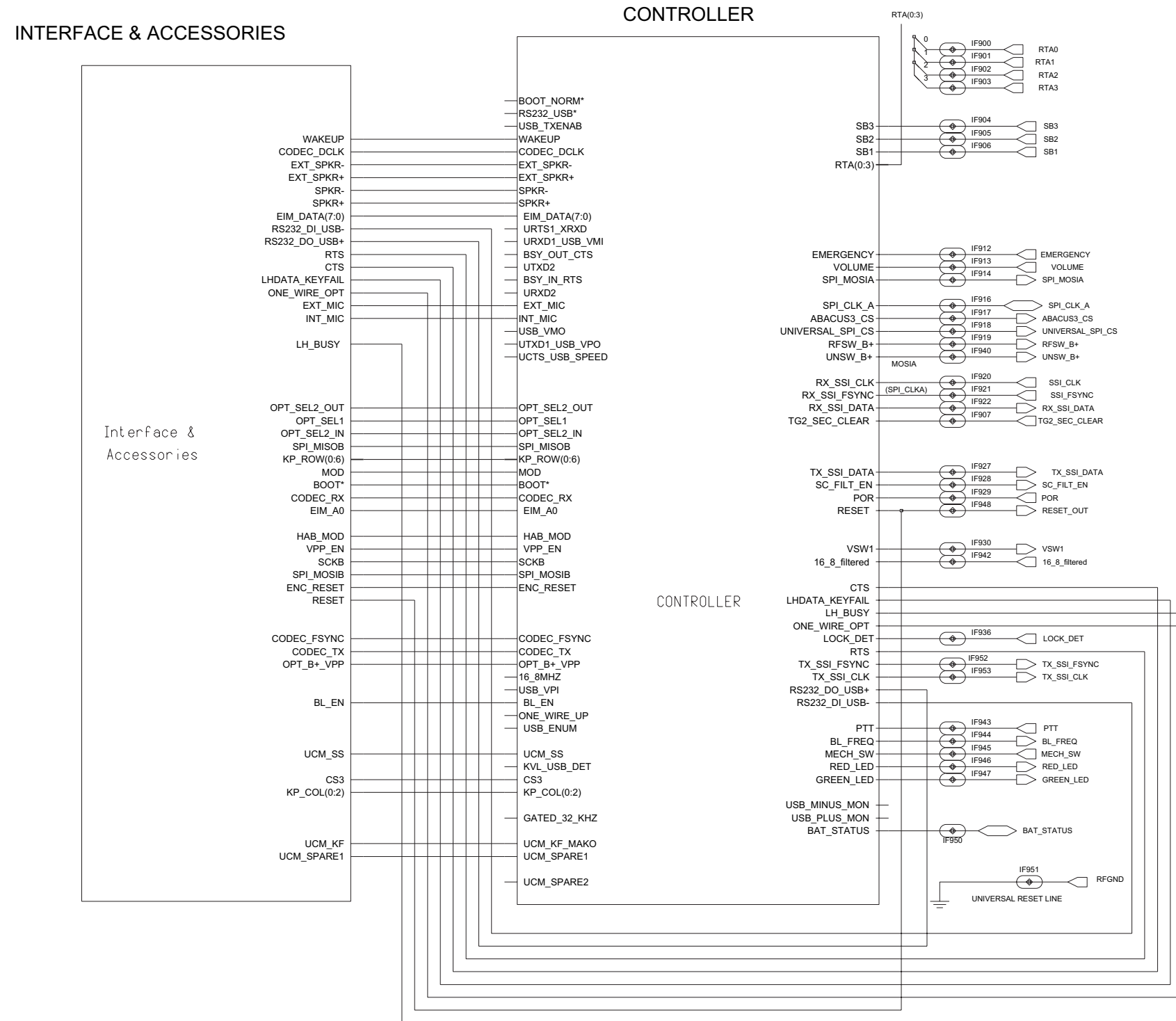

Figure 9.2-3. PMLE2537A/ PMLE2537D Controller Interface Schematic

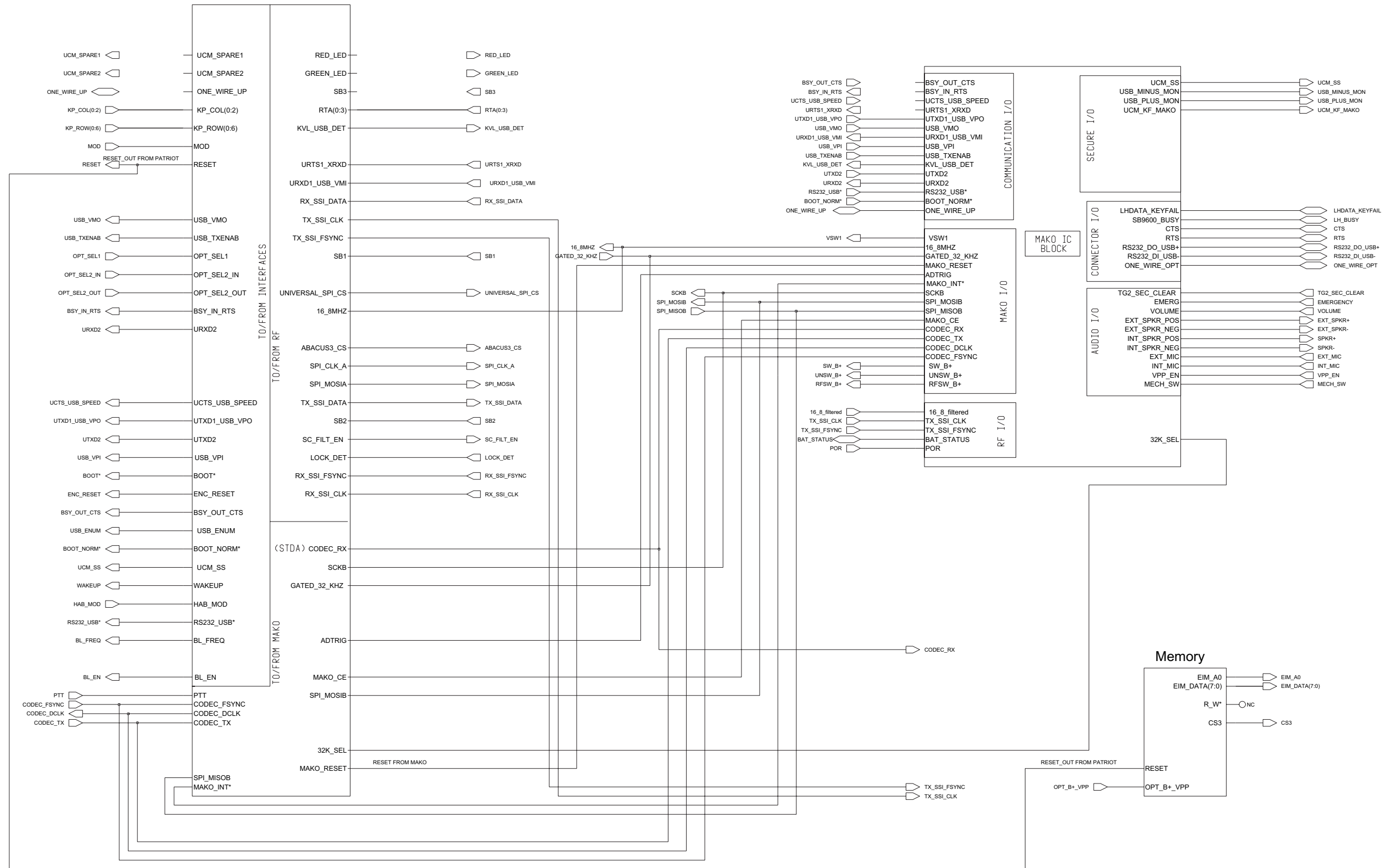

Figure 9.2-4. PMLE2537A/ PMLE2537D Controller Schematic

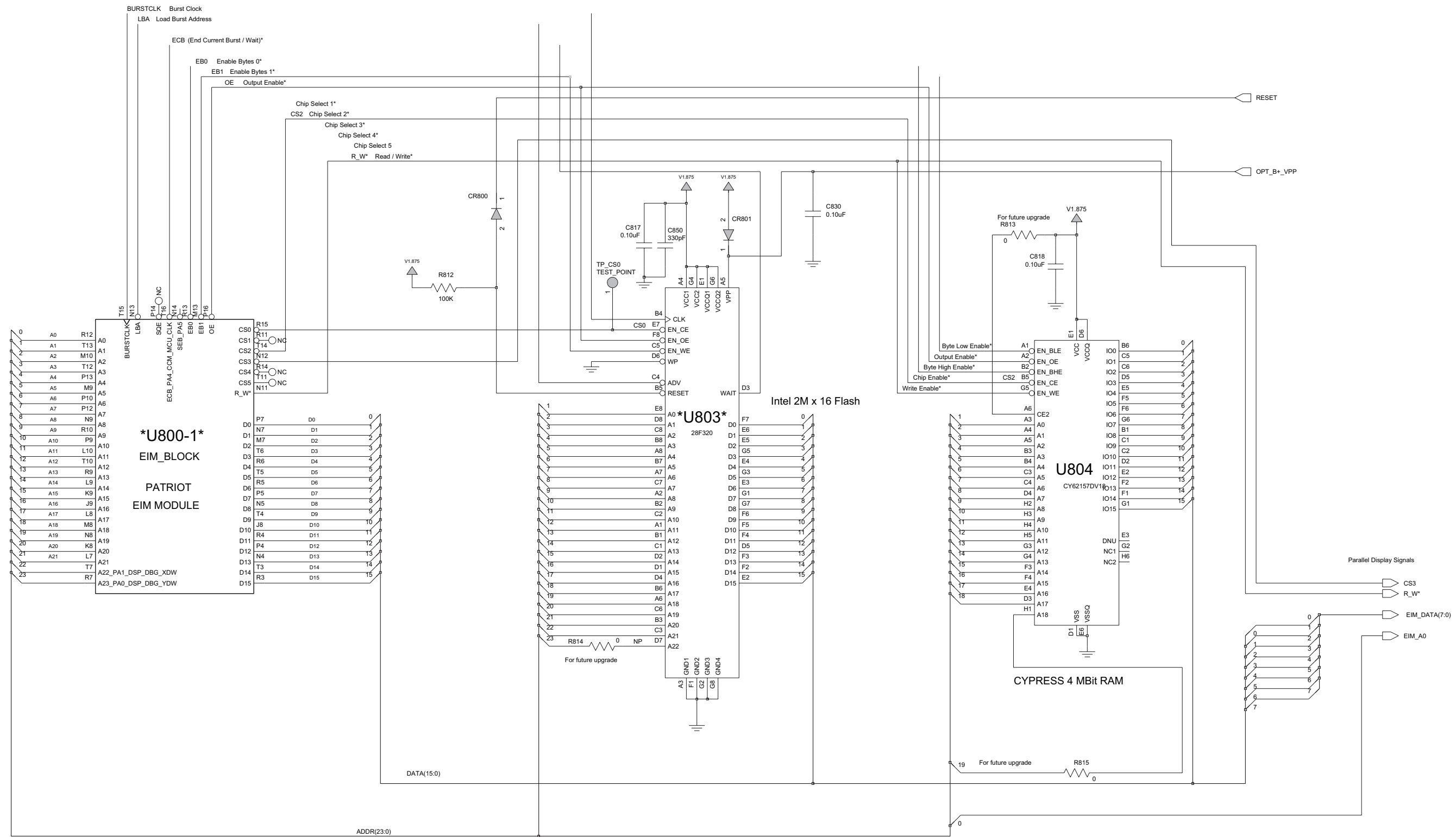

Figure 9.2-5. PMLE2537A/ PMLE2537D Memory Schematic

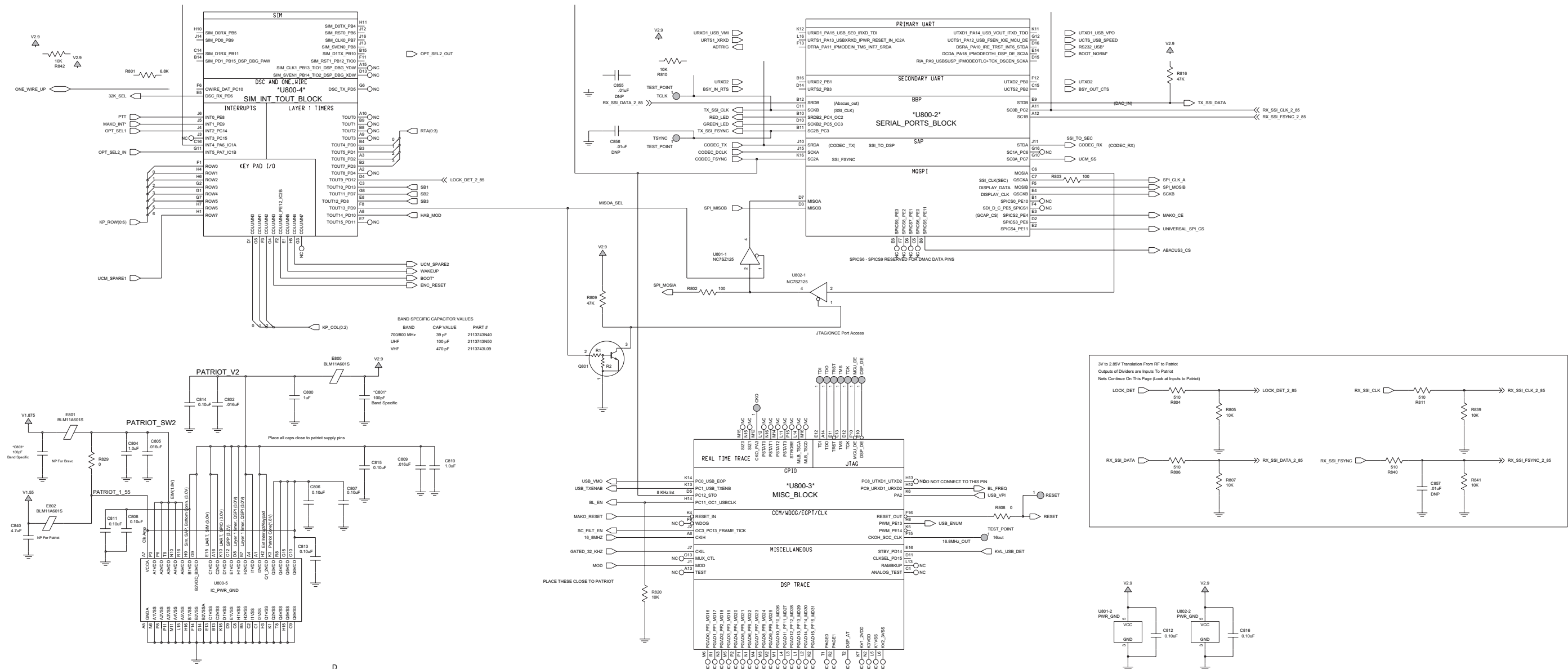

Figure 9.2-6. PMLE2537A/ PMLE2537D Patriot Bravo (U800) Schematic

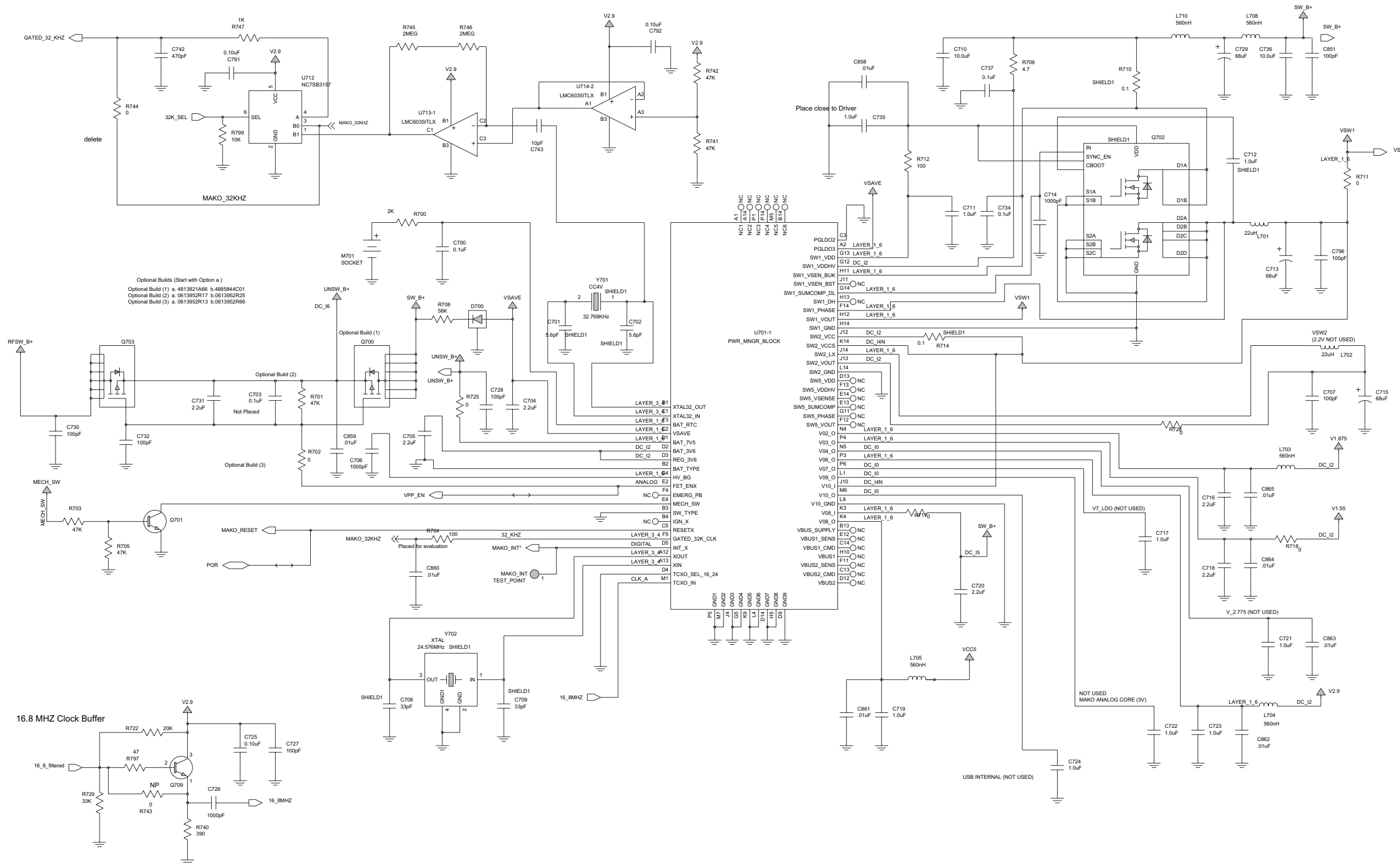

Figure 9.2-7. PMLE2537A/ PMLE2537D MAKO DC and Audio Schematic - Sheet 1 of 2

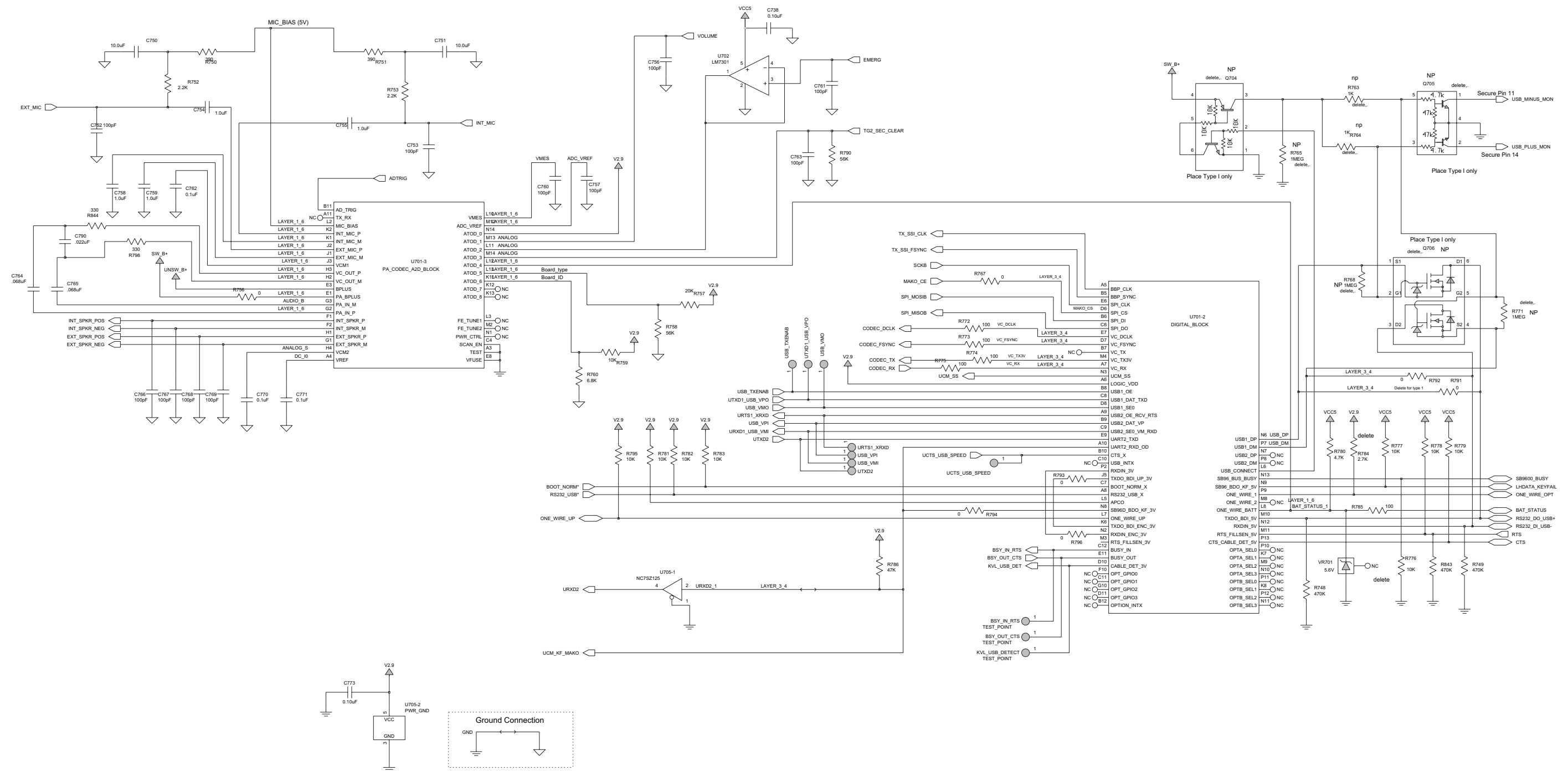

Figure 9.2-8. PMLE2537A/ PMLE2537D MAKO DC and Audio Schematic - Sheet 2 of 2

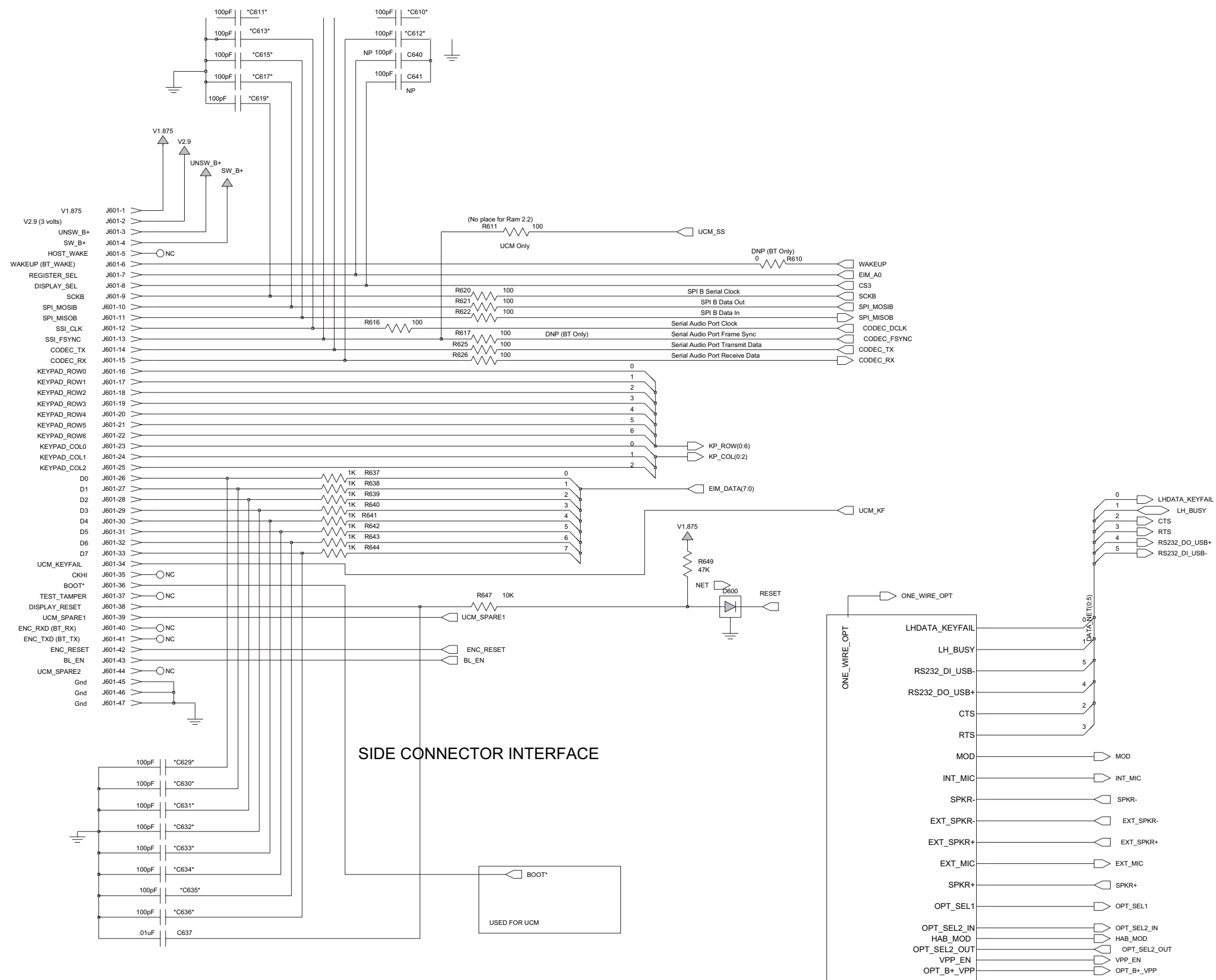

Figure 9.2-9. PMLE2537A/ PMLE2537D Interface and Accessories Schematic

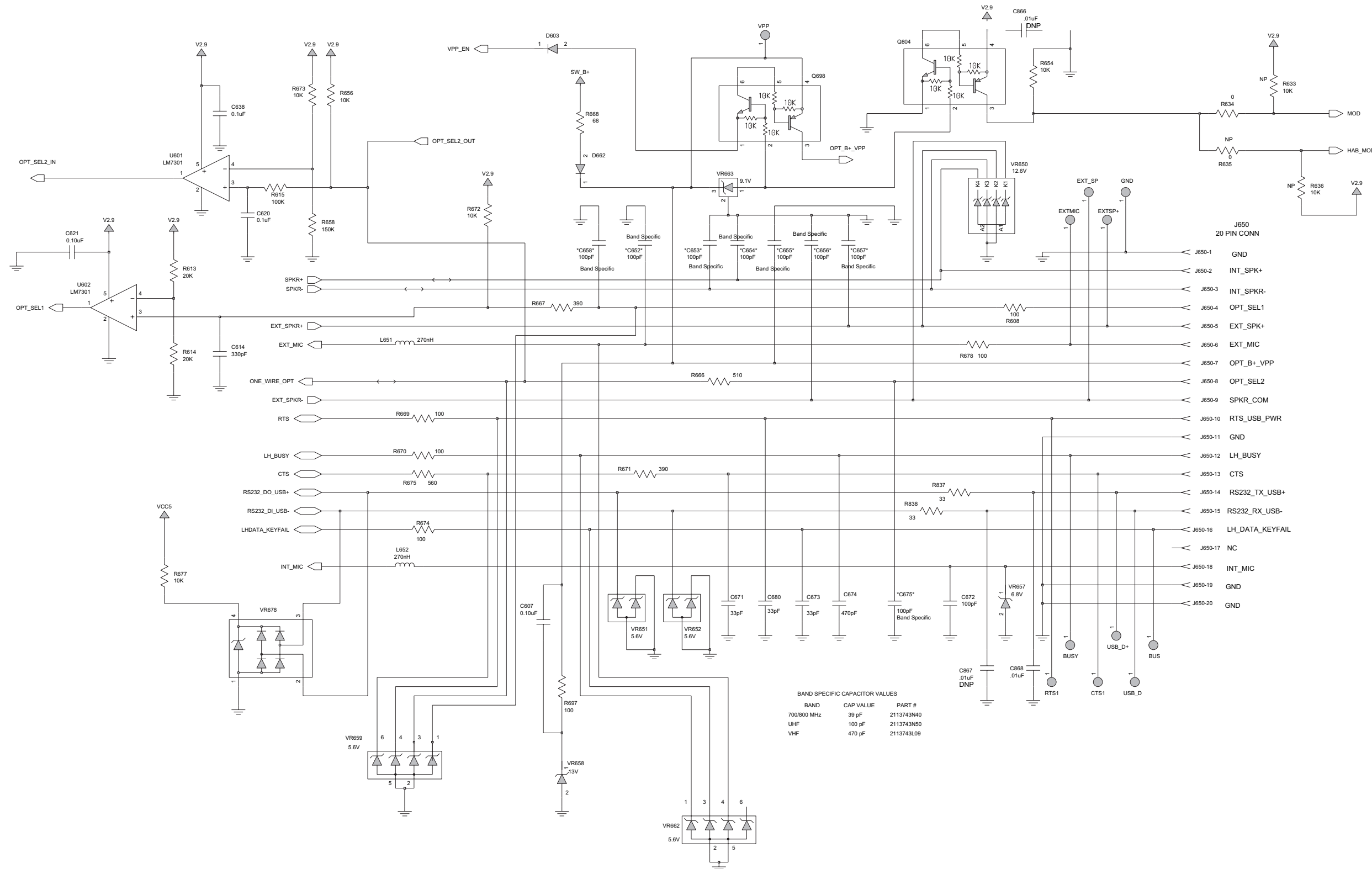

Figure 9.2-10. PMLE2537A/ PMLE2537D Side Connector Schematic

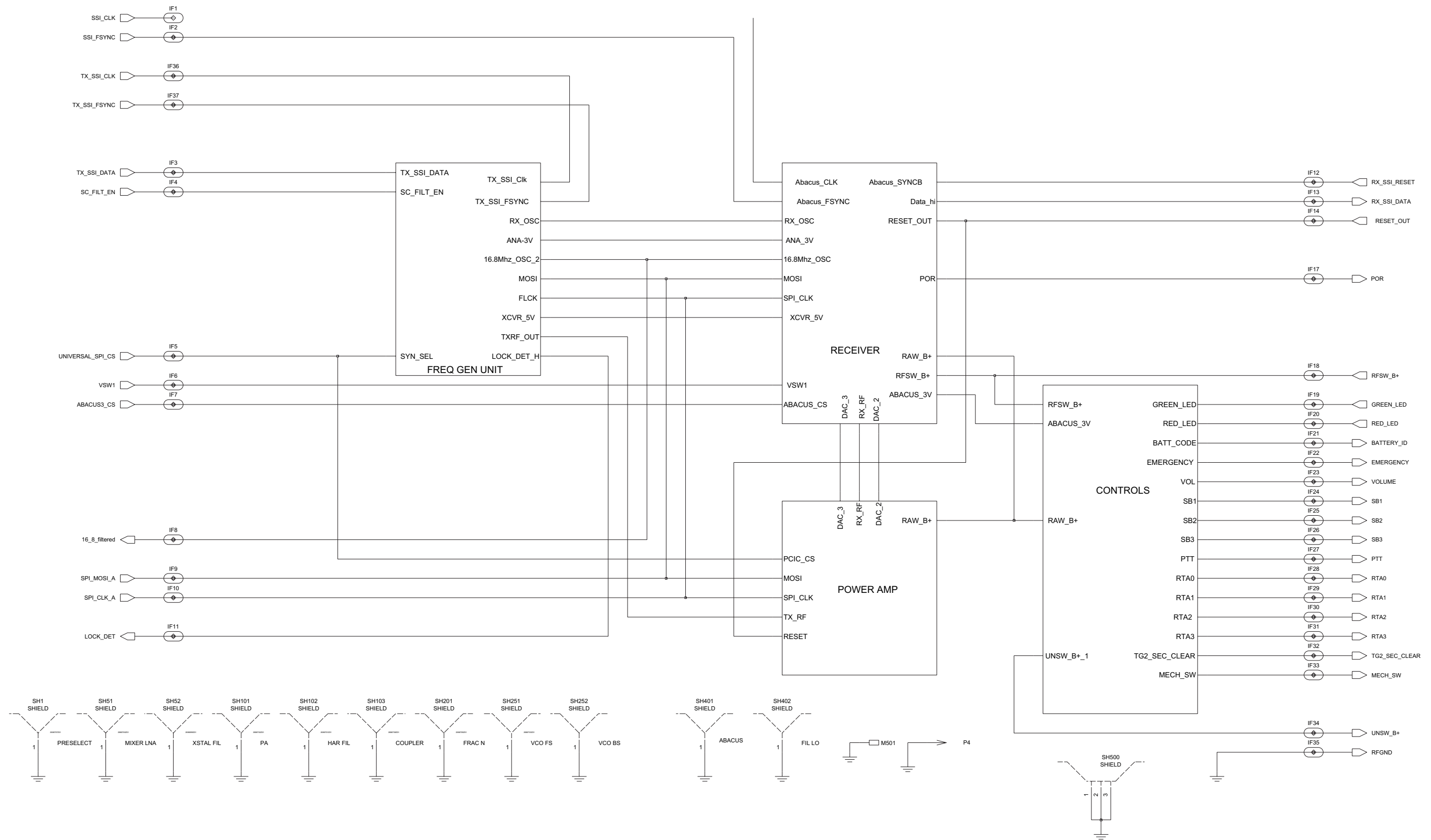

Figure 9.2-11. PMLE2537A/ PMLE2537D RF Schematic

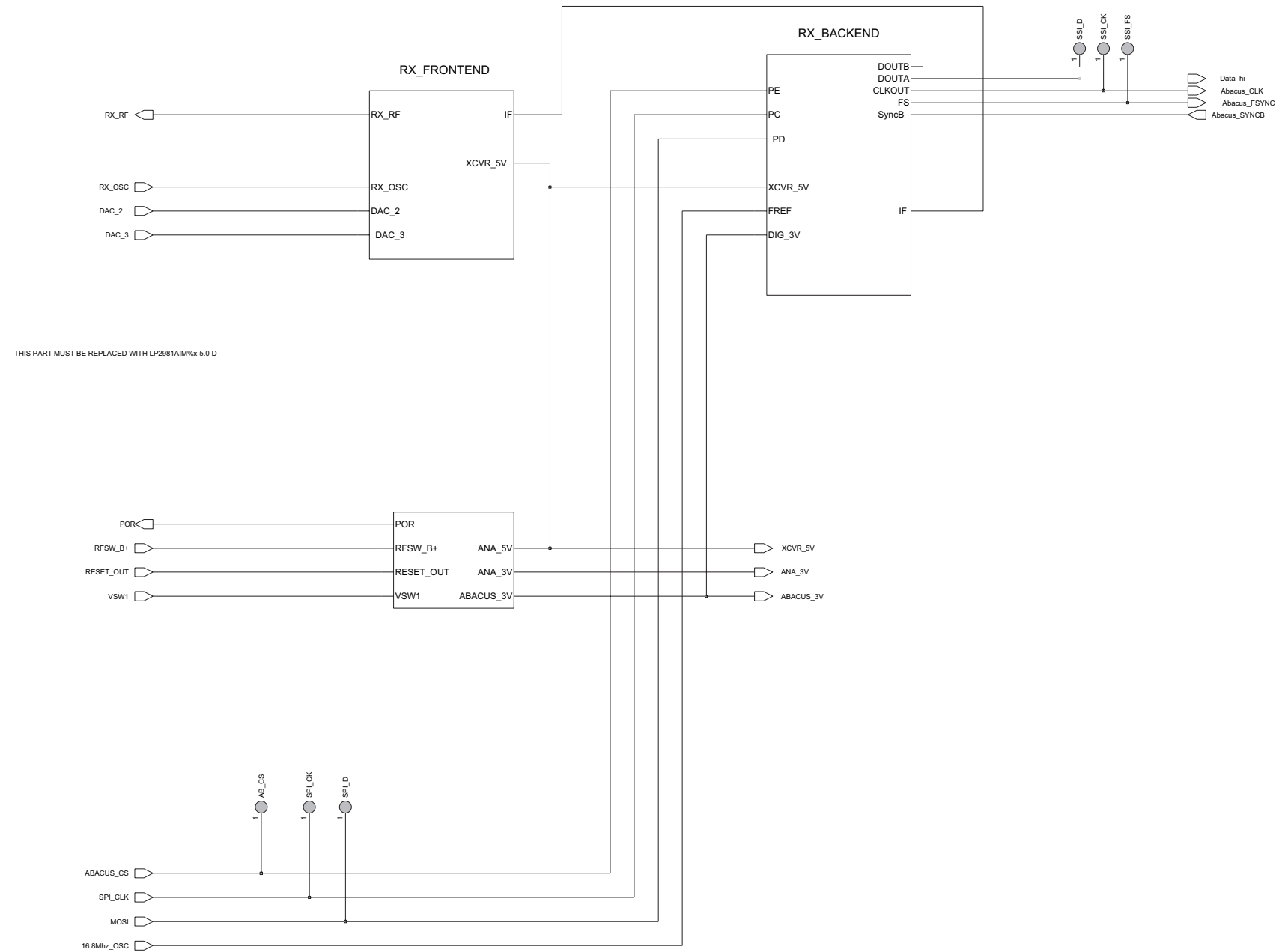

Figure 9.2-12. PMLE2537A/ PMLE2537D Receiver Front End and DC Schematic

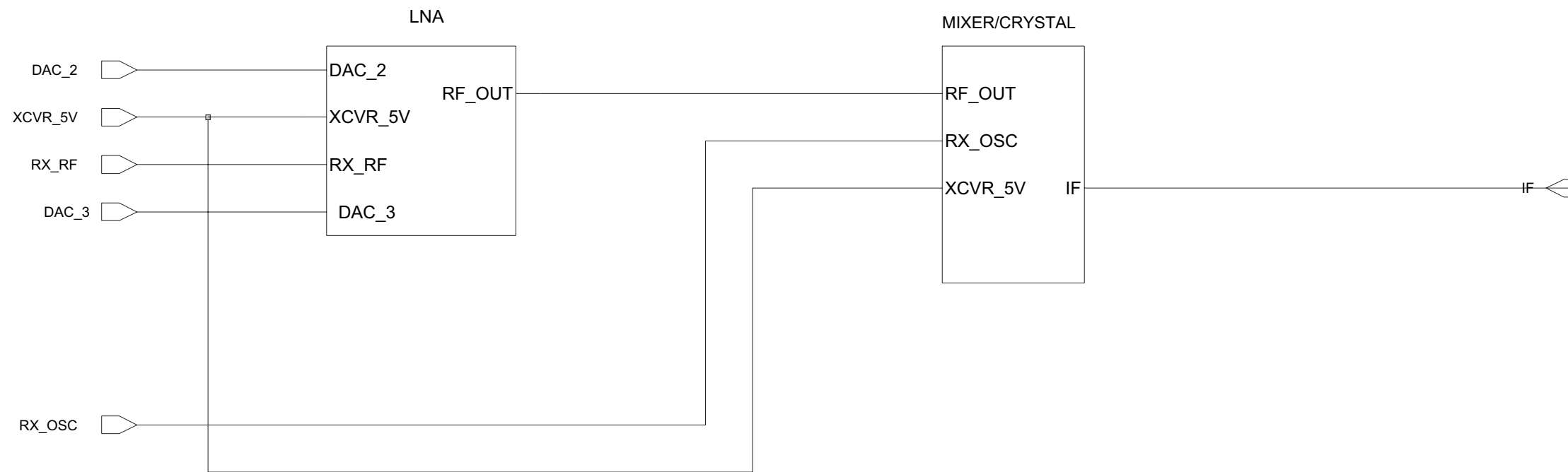

Figure 9.2-13. PMLE2537A/ PMLE2537D Receiver Front End Schematic

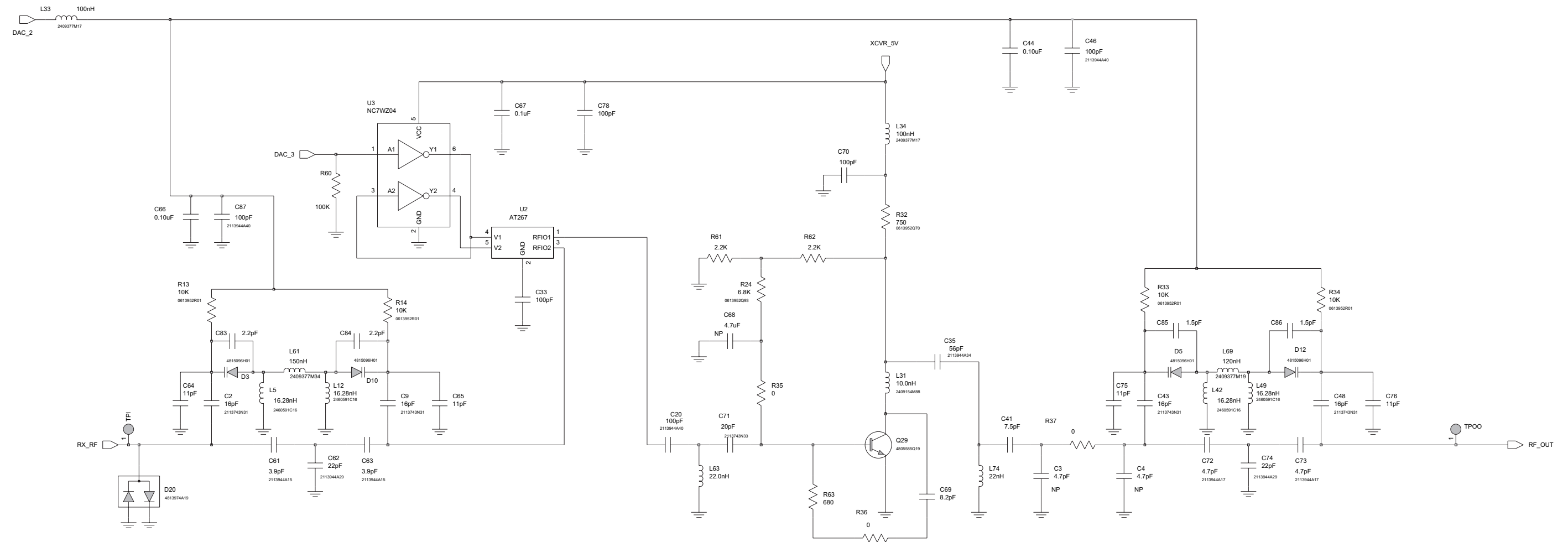

Figure 9.2-14. PMLE2537A/ PMLE2537D Receiver Schematic - Sheet 1 of 4

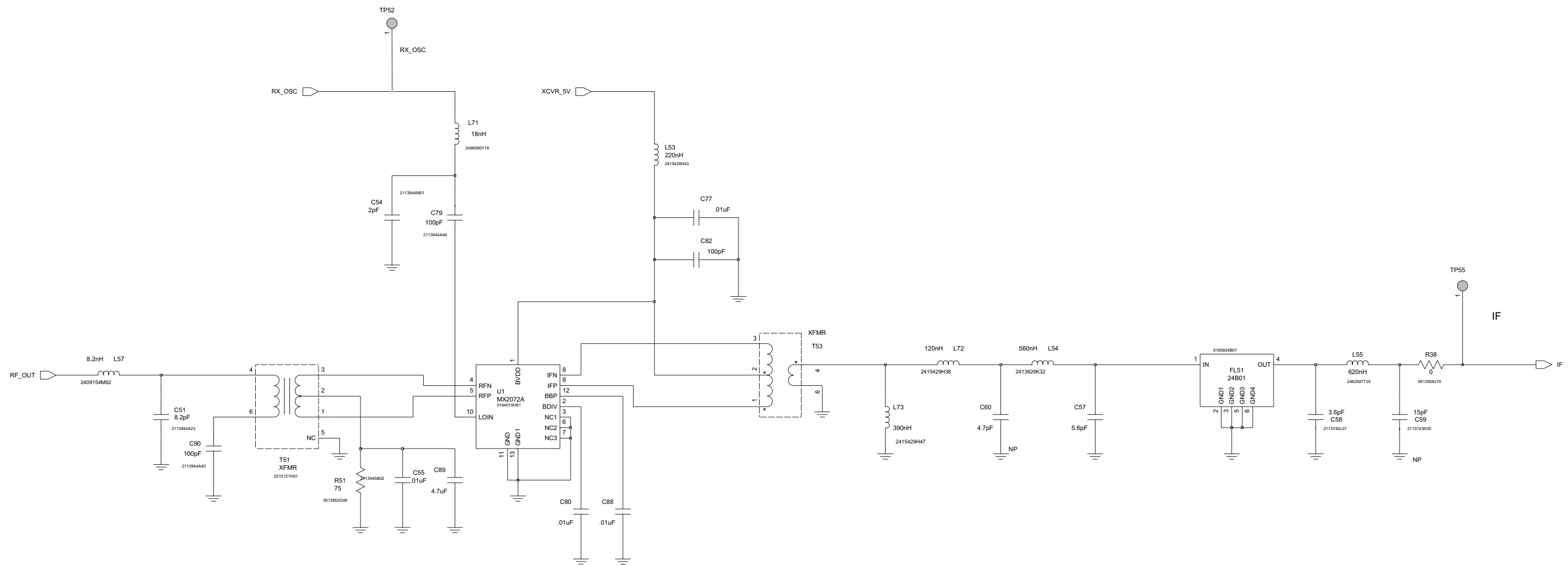

Figure 9.2-15. PMLE2537A/ PMLE2537D Receiver Schematic - Sheet 2 of 4

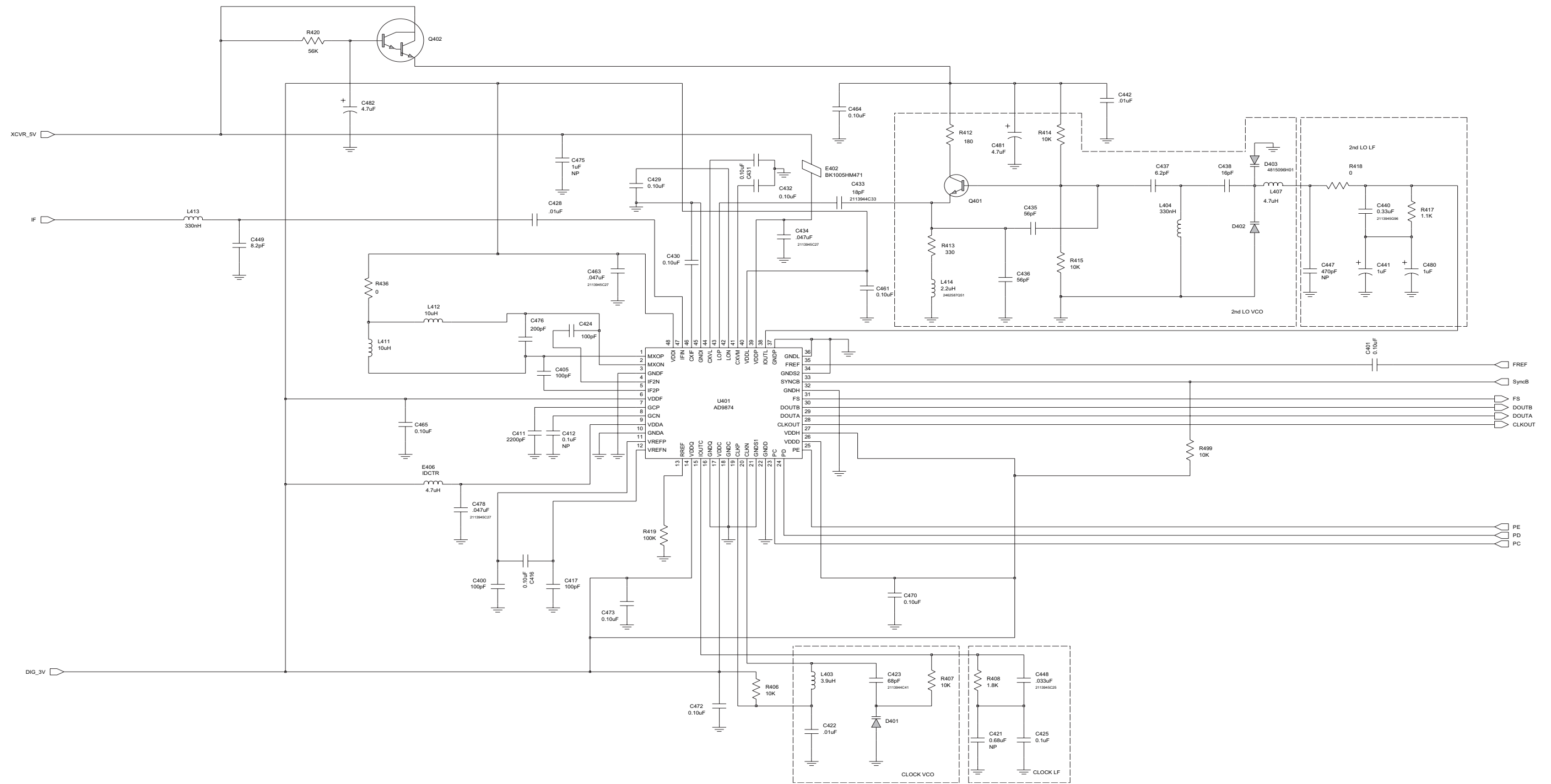

Figure 9.2-16. PMLE2537A/ PMLE2537D Receiver Schematic - Sheet 3 of 4

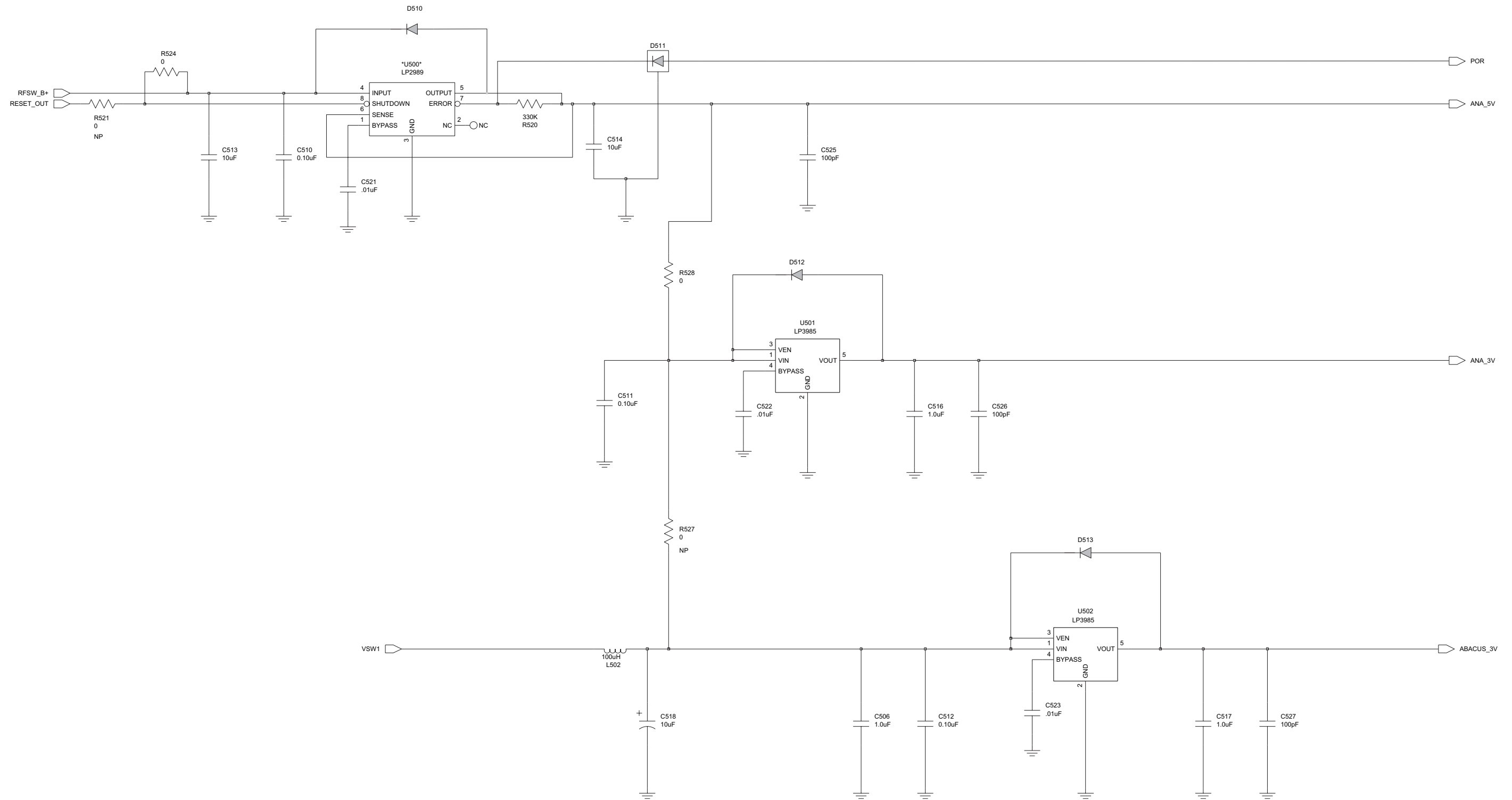

Figure 9.2-17. PMLE2537A/ PMLE2537D Receiver Schematic, Regulators - Sheet 4 of 4

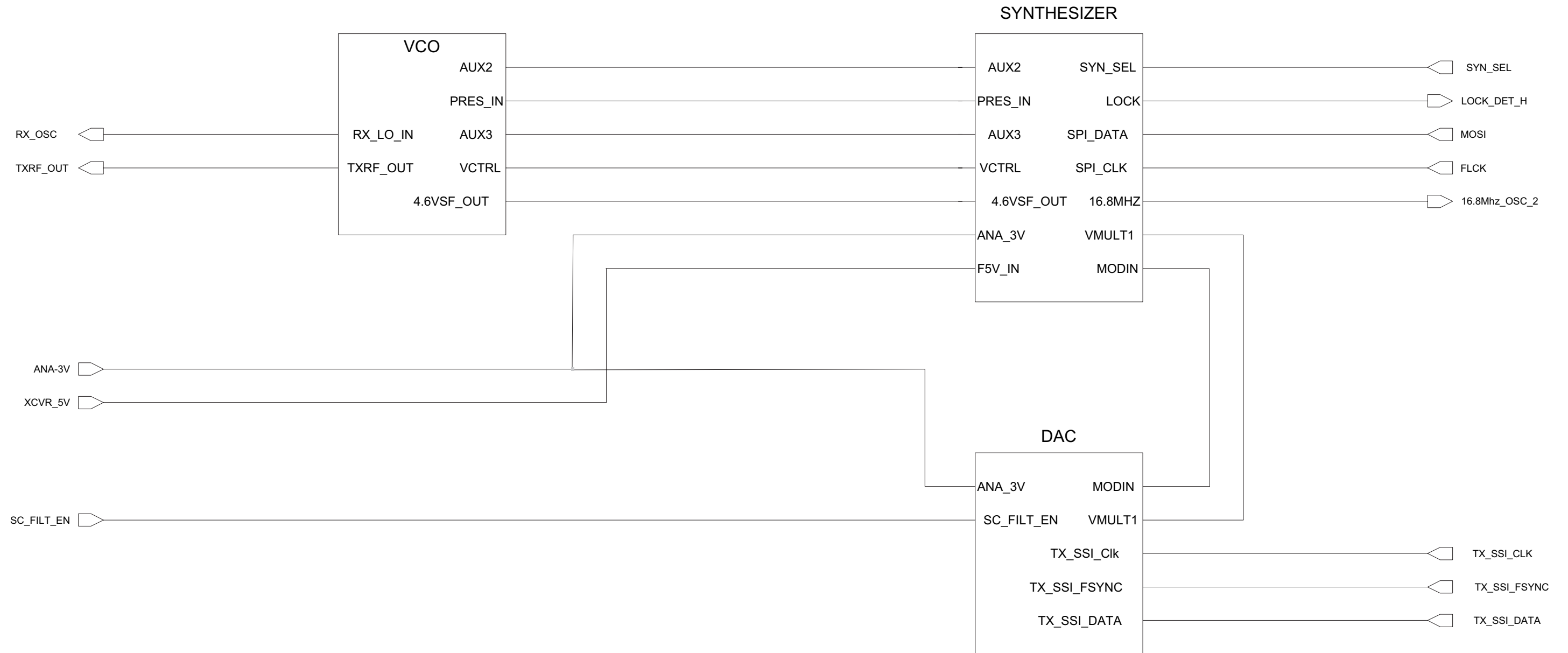

Figure 9.2-18. PMLE2537A/ PMLE2537D Frequency Generation Unit (FGU) and Digital to Analog Converter (DAC) Schematic

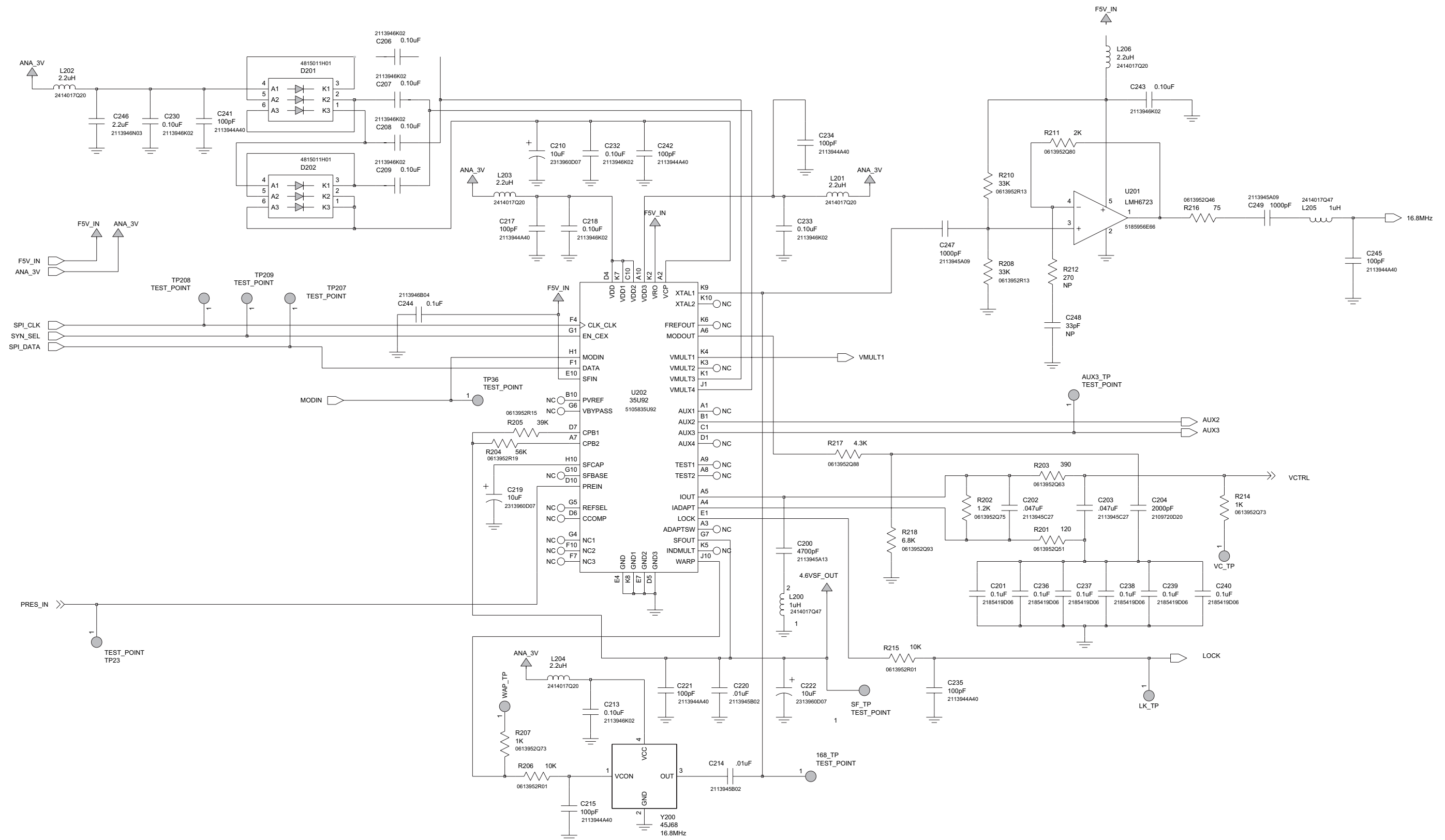

Figure 9.2-19. PMLE2537A Frequency Generation Unit (FGU) Schematic - Sheet 1 of 4

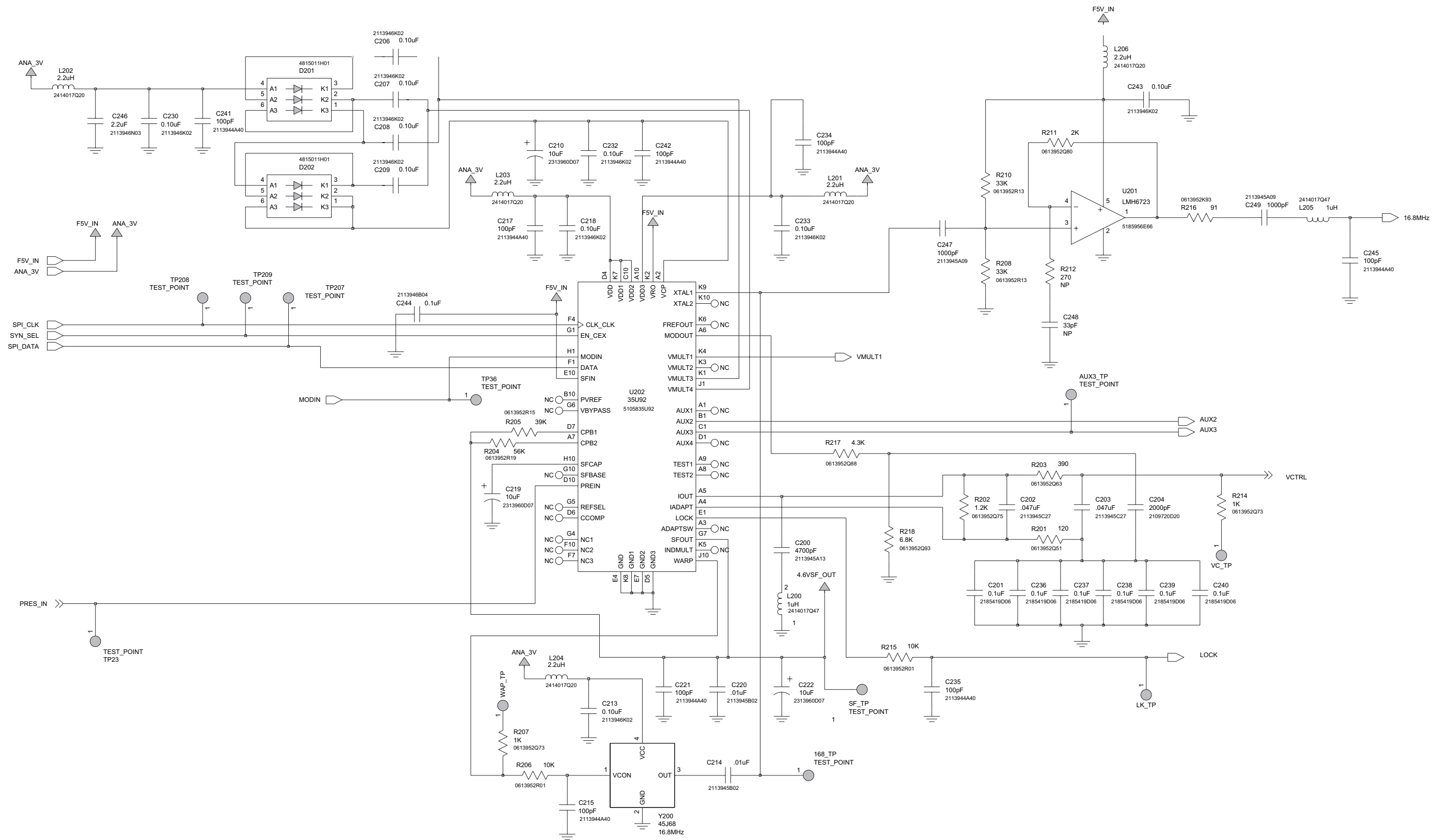

Figure 9.2-20. PMLE2537D Frequency Generation Unit (FGU) Schematic - Sheet 1 of 4

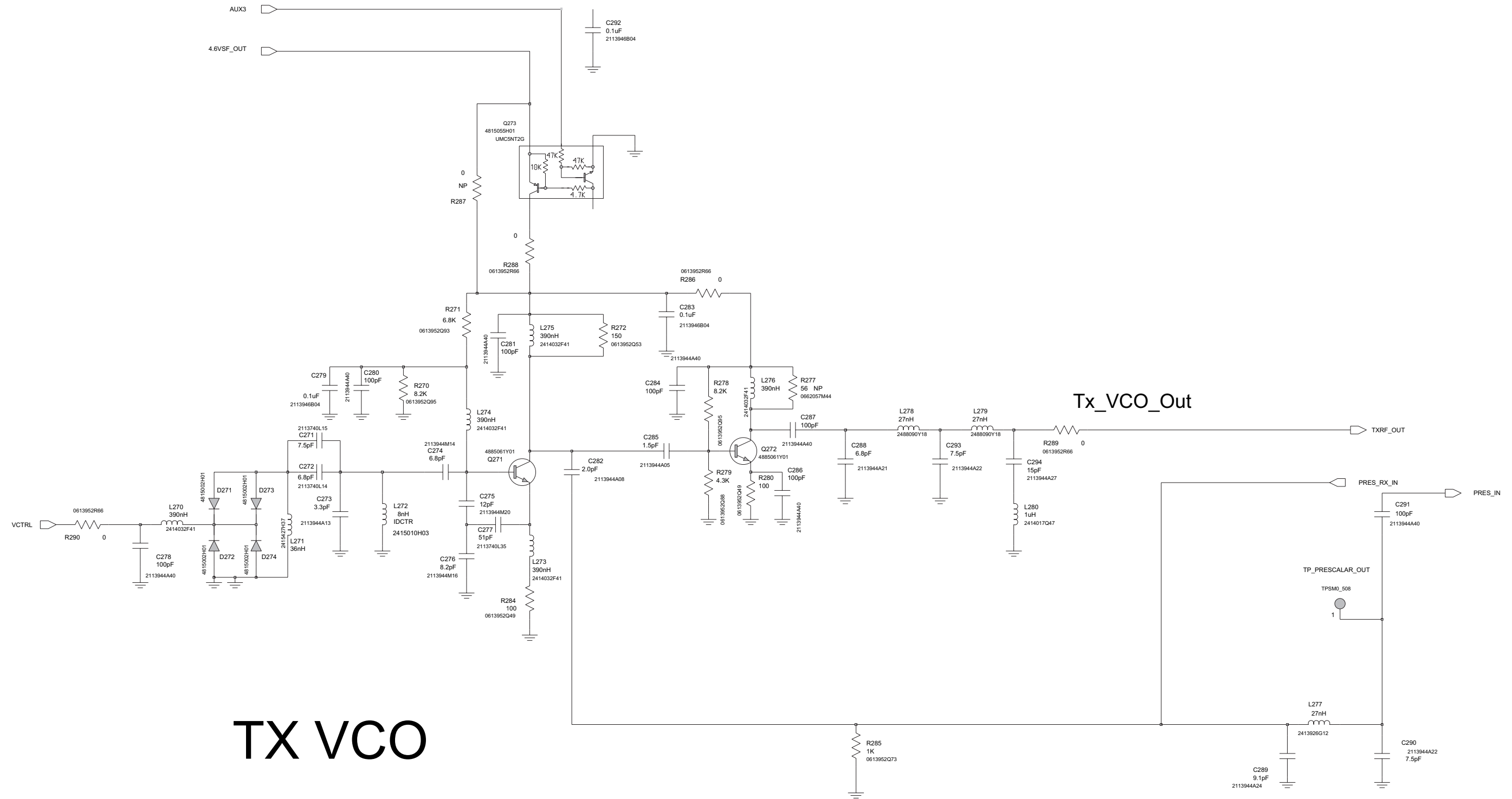

Figure 9.2-21. PMLE2537A/ PMLE2537D Frequency Generation Unit (FGU) Schematic - Sheet 2 of 4

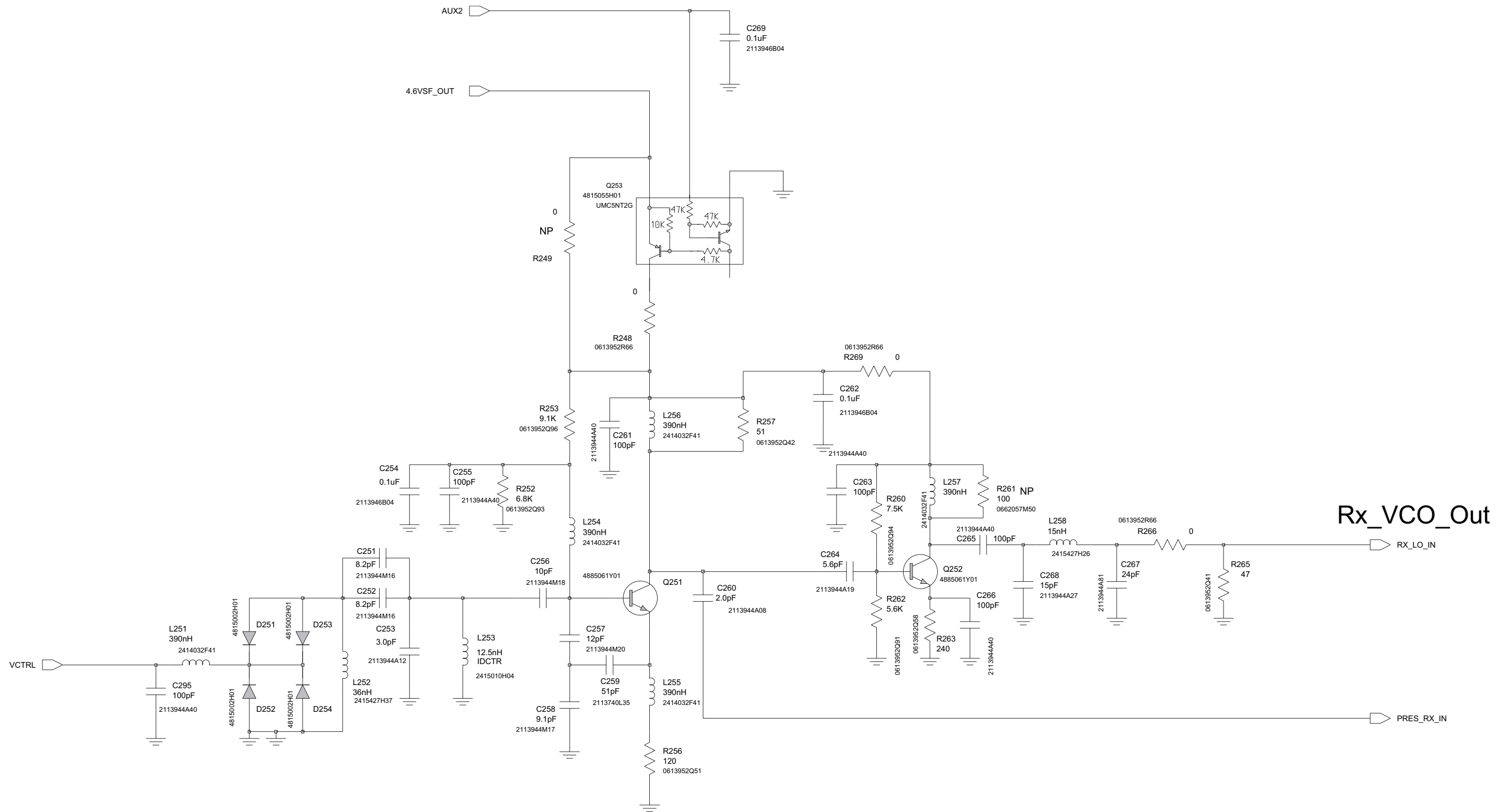

Figure 9.2-22. PMLE2537A/ PMLE2537D Frequency Generation Unit (FGU) Schematic - Sheet 3 of 4

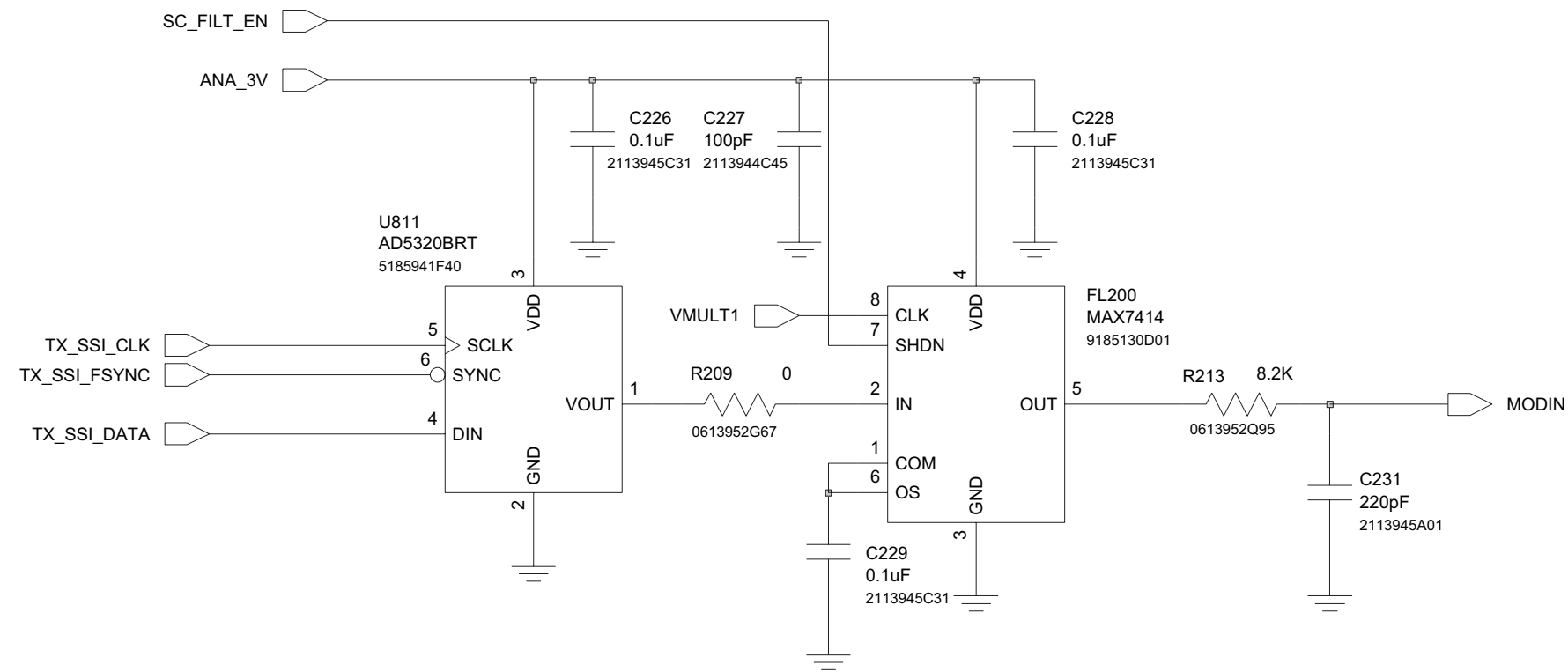

Figure 9.2-23. PMLE2537A/ PMLE2537D Frequency Generation Unit (FGU) Schematic - Sheet 4 of 4

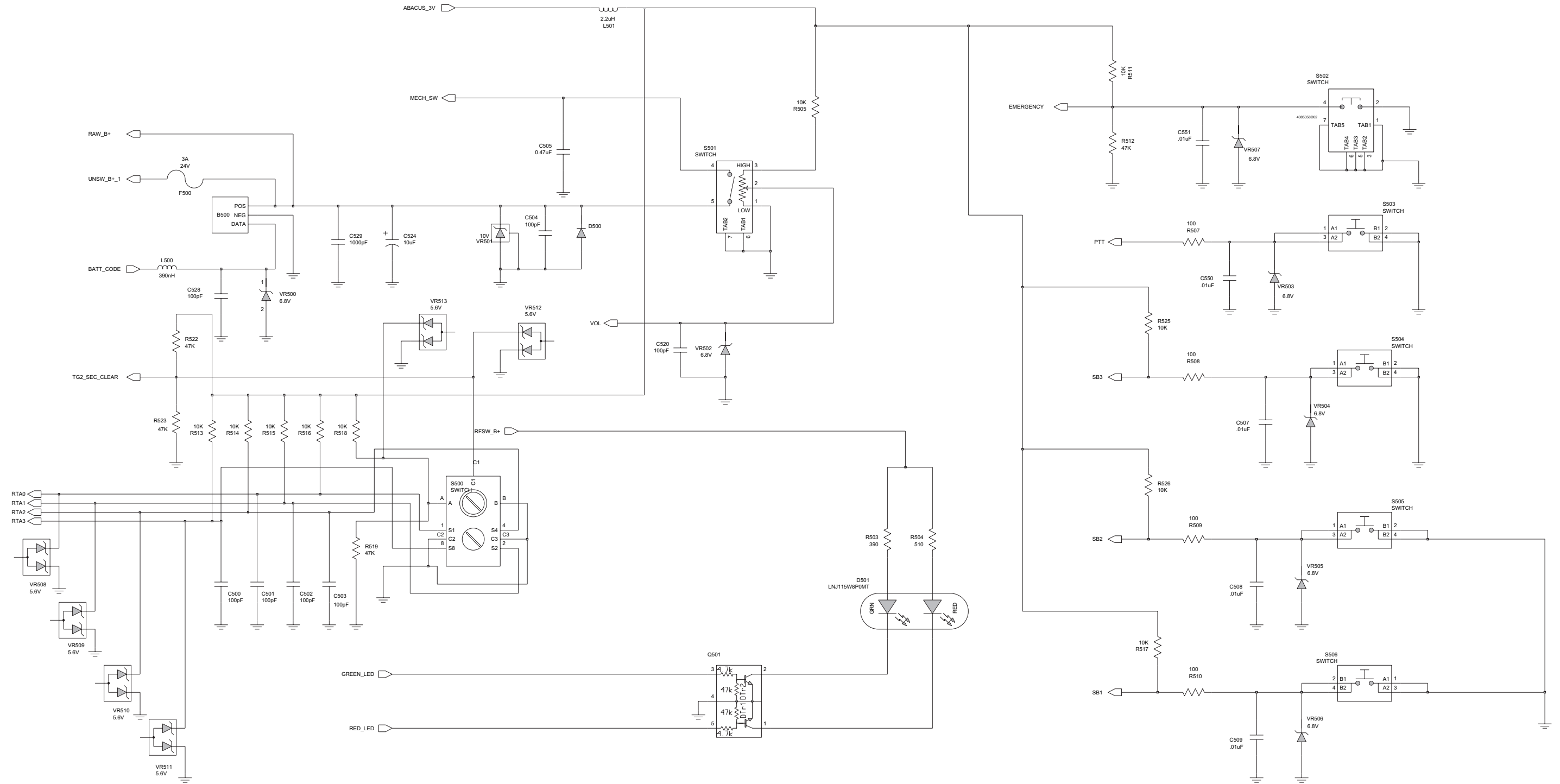

Figure 9.2-24. PMLE2537A RF Controls Schematic

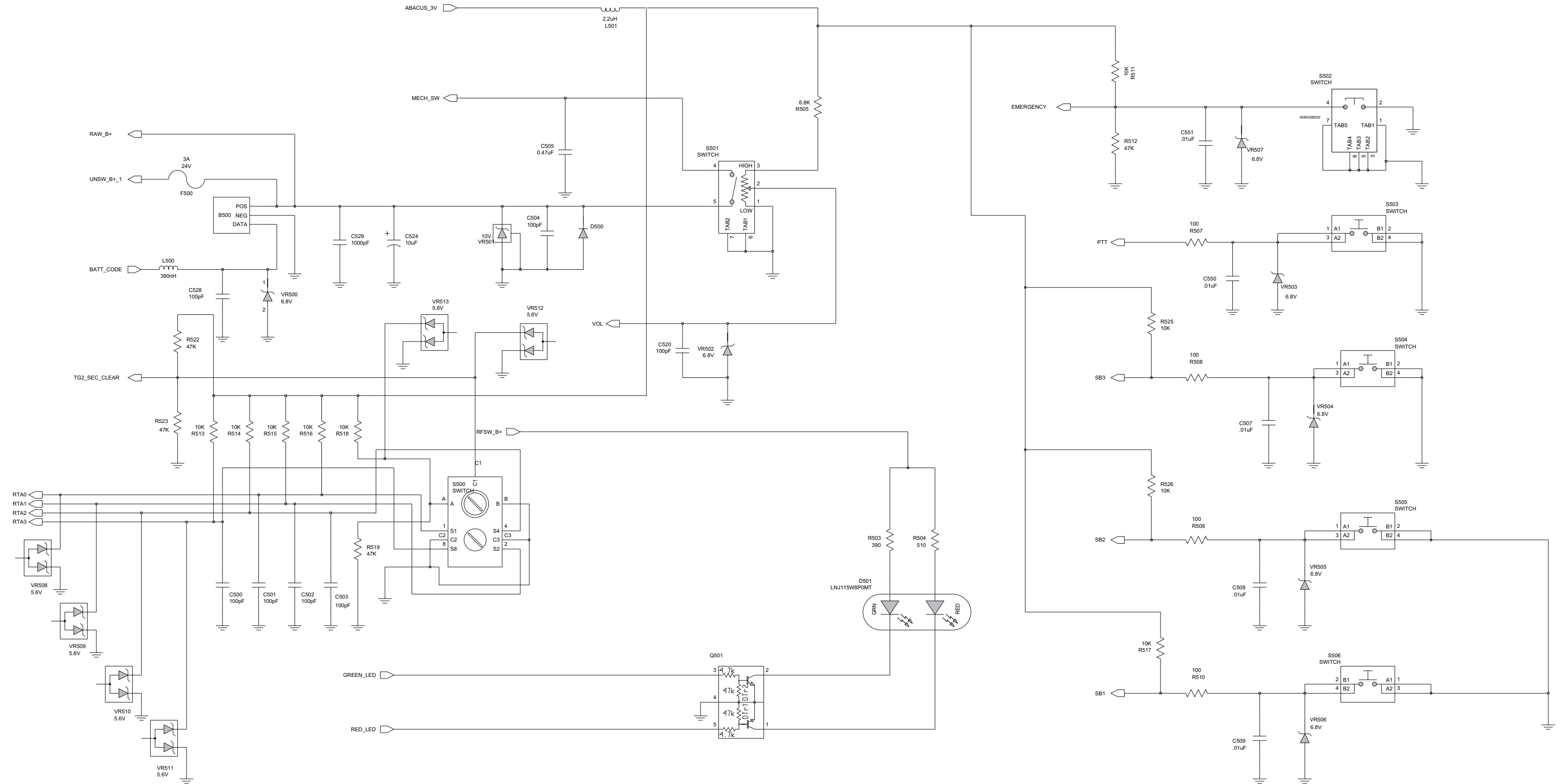

Figure 9.2-25. PMLE2537D RF Controls Schematic

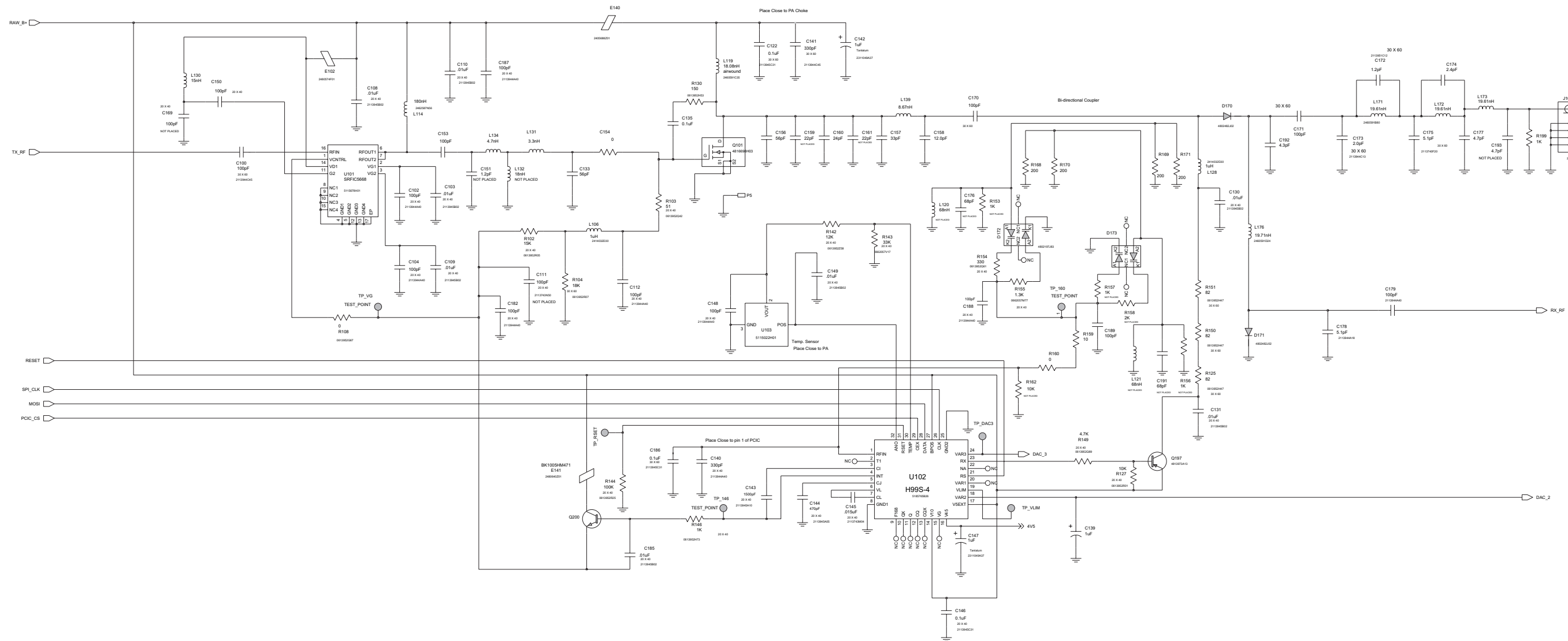

Figure 9.2-26. PMLE2537A/ PMLE2537D Transmitter Schematic

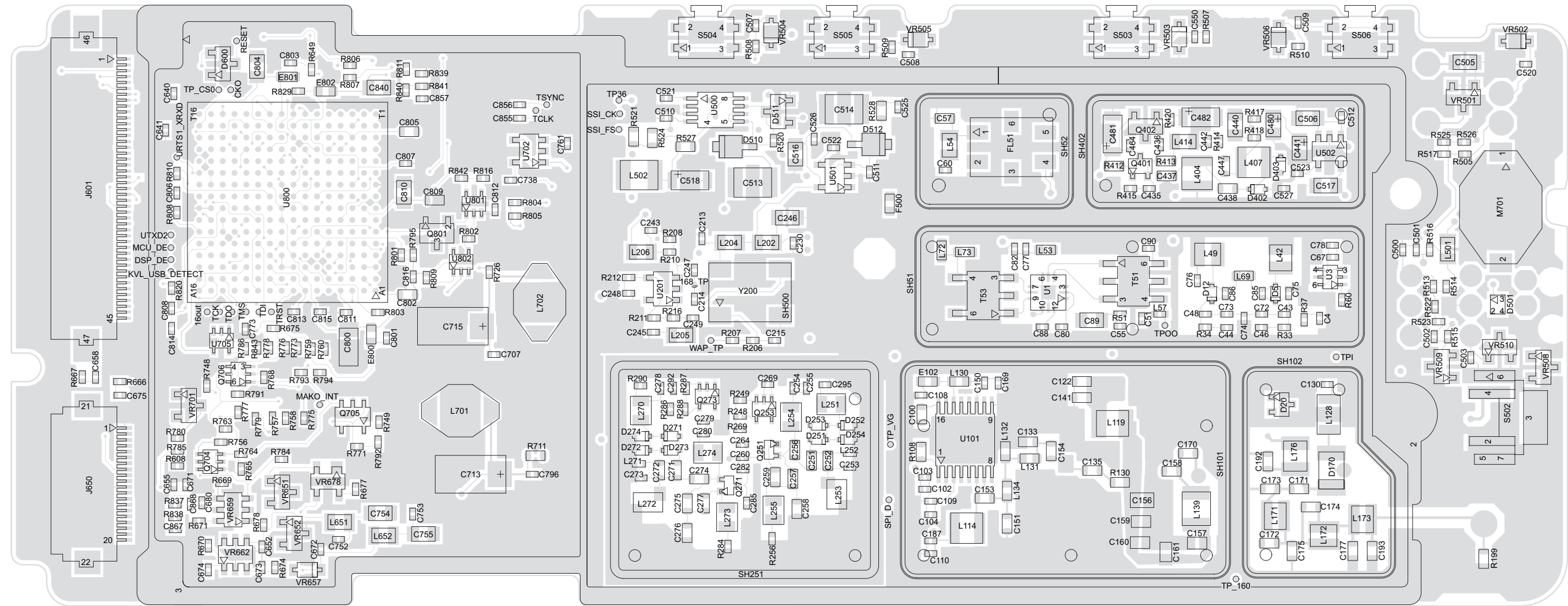

Figure 9.2-27. PMLE2537A/ PMLE2537D Main Circuit Board Component Location Detail - Top Side

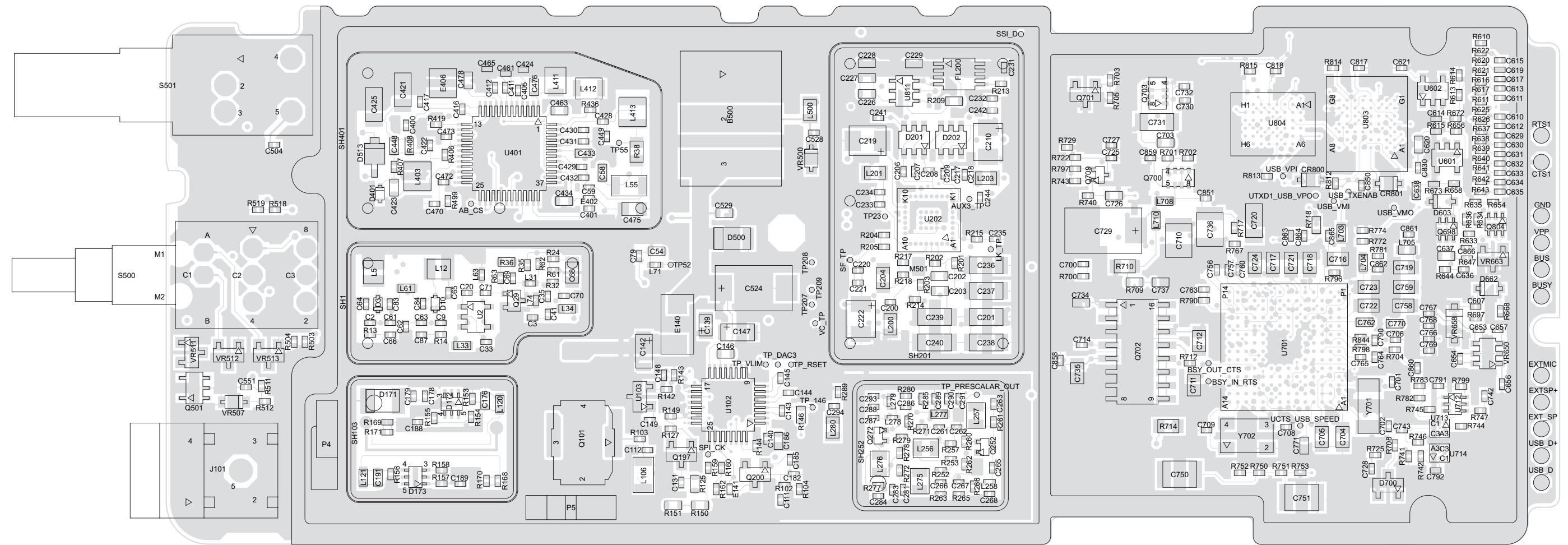

Figure 9.2-28. PMLE2537A/ PMLE2537D Main Circuit Board Component Location Detail - Bottom Side

PMLE2537A/ PMLE2537D Main Circuit Board
 Electrical Parts List

ITEM	MOTOROLA PART NUMBER	DESCRIPTION
PCB	8416617H02	BOARD, PC, UHF BAND 1 (MAKO)
B500	0986237A02	CONNECTOR (CONTACT BATTERY)
C2	2113944A79	CAP,FXD,16PF,+5%,-5%,50V-DC,0402,C0G,-55DEG C
C3	NOTPLACED	
C4	NOTPLACED	
C9	2113944A79	CAP,FXD,16PF,+5%,-5%,50V-DC,0402,C0G,-55DEG C
C20	2113944A40	CAP CER CHP 100.0PF 50V 5%
C33	2113944A40	CAP CER CHP 100.0PF 50V 5%
C35	2113944A34	CAP CER CHP 56.0PF 50V 5%
C41	2113944A22	CAP CER CHP 7.5PF 50V +/- 0.5PF
C43	2113944A79	CAP,FXD,16PF,+5%,-5%,50V-DC,0402,C0G,-55DEG C
C44	2113946K02	CAP CER CHP 0.10UF 16V
C46	2113944A40	CAP CER CHP 100.0PF 50V 5%
C48	2113944A79	CAP,FXD,16PF,+5%,-5%,50V-DC,0402,C0G,-55DEG C
C51	2113944A23	CAP CER CHP 8.2PF 50V +/- 0.5PF
C54	2113944M01	CAP,FXD,2PF,.1PF+/-,50V-DC,0603,C0G,-55DEG CM
C55	2113945B02	CAP CER CHP 10,000PF 25V 10%
C57	2113944M12	CAP,FXD,5.6PF,.1PF+/-,50V-DC,0603,C0G,-55DEG
C58	2113944M07	CAP,FXD,3.6PF,.1PF+/-,50V-DC,0603,C0G,-55DEG
C59	NOTPLACED	
C60	NOTPLACED	
C61	2113944A15	CAP CER CHP 3.9PF 50V +/- 0.25PF

ITEM	MOTOROLA PART NUMBER	DESCRIPTION
C62	2113944A29	CAP CER CHP 22.0PF 50V 5%
C63	2113944A15	CAP CER CHP 3.9PF 50V +/- 0.25PF
C64	2113944A77	CAP,FXD,11PF,+5%,-5%,50V-DC,0402,C0G,-55DEG C
C65	2113944A77	CAP,FXD,11PF,+5%,-5%,50V-DC,0402,C0G,-55DEG C
C66	2113946K02	CAP CER CHP 0.10UF 16V
C67	2113946B04	CAP CER CHP 0.10UF 10V 10%
C68	NOTPLACED	
C69	2113944A23	CAP CER CHP 8.2PF 50V +/- 0.5PF
C70	2113944A40	CAP CER CHP 100.0PF 50V 5%
C71	2113944A80	CAP,FXD,20PF,+5%,-5%,50V-DC,0402,C0G,-55DEG C
C72	2113944A17	CAP CER CHP 4.7PF 50V +/- 0.25PF
C73	2113944A17	CAP CER CHP 4.7PF 50V +/- 0.25PF
C74	2113944A29	CAP CER CHP 22.0PF 50V 5%
C75	2113944A77	CAP,FXD,11PF,+5%,-5%,50V-DC,0402,C0G,-55DEG C
C76	2113944A77	CAP,FXD,11PF,+5%,-5%,50V-DC,0402,C0G,-55DEG C
C77	2113945B02	CAP CER CHP 10,000PF 25V 10%
C78	2113944A40	CAP CER CHP 100.0PF 50V 5%
C79	2113944A40	CAP CER CHP 100.0PF 50V 5%
C80	2113945B02	CAP CER CHP 10,000PF 25V 10%
C82	2113944A40	CAP CER CHP 100.0PF 50V 5%
C83	2113944A09	CAP CER CHP 2.2PF 50V +/- 0.25PF
C84	2113944A09	CAP CER CHP 2.2PF 50V +/- 0.25PF
C85	2113944A07	CAP CER CHP 1.8PF 50V +/- 0.25PF

ITEM	MOTOROLA PART NUMBER	DESCRIPTION
C86	2113944A07	CAP CER CHP 1.8PF 50V +/- 0.25PF
C87	2113944A40	CAP CER CHP 100.0PF 50V 5%
C88	2113945B02	CAP CER CHP 10,000PF 25V 10%
C89	2113946F03	CAP CER CHP 4.7UF 6.3V 10%
C90	2113944A40	CAP CER CHP 100.0PF 50V 5%
C100	2113944C45	CAP CER CHP 100.0PF 50V 5%
C102	2113944A40	CAP CER CHP 100.0PF 50V 5%
C103	2113945B02	CAP CER CHP 10,000PF 25V 10%
C104	2113944A40	CAP CER CHP 100.0PF 50V 5%
C108	2113945B02	CAP CER CHP 10,000PF 25V 10%
C109	2113945B02	CAP CER CHP 10,000PF 25V 10%
C110	2113945B02	CAP CER CHP 10,000PF 25V 10%
C111	NOTPLACED	
C112	2113944A40	CAP CER CHP 100.0PF 50V 5%
C122	2113945C31	CAP,FXD,.1UF,+10%,-10%,50V-DC,0603,X7R,-55DEG
C130	2113945B02	CAP CER CHP 10,000PF 25V 10%
C131	2113945B02	CAP CER CHP 10,000PF 25V 10%
C133	2113944C39	CAP CER CHP 56.0PF 50V 5%
C135	2113945C31	CAP,FXD,.1UF,+10%,-10%,50V-DC,0603,X7R,-55DEG
C139	2313960M26	CAP,FXD,1UF,+10%,-10%,10V-DC,SM,-55DEG CMIN,
C140	2113944A40	CAP CER CHP 100.0PF 50V 5%
C141	2113944C45	CAP CER CHP 100.0PF 50V 5%
C142	2313960A76	CAP,FXD,1UF,+10%,-10%,20V-DC,SM,-55DEG CMIN,
C143	2113945A10	CAP CER CHP 1500PF 50V 10%

ITEM	MOTOROLA PART NUMBER	DESCRIPTION
C144	2113945A05	CAP CER CHP 470PF 50V 10%
C145	2113945B03	CAP,FXD,.015UF,+10%,-10%,25V-DC,0402,X7R,-55
C146	2113945C31	CAP,FXD,.1UF,+10%,-10%,50V-DC,0603,X7R,-55DEG
C147	2313960A76	CAP,FXD,1UF,+10%,-10%,20V-DC,SM,-55DEG CMIN,
C148	2113944A40	CAP CER CHP 100.0PF 50V 5%
C149	2113945B02	CAP CER CHP 10,000PF 25V 10%
C150	2113944A40	CAP CER CHP 100.0PF 50V 5%
C151	NOTPLACED	
C153	2113944C45	CAP CER CHP 100.0PF 50V 5%
C154	0613952G67	CER CHIP RES 0.0 +/-0.050 OHM
C156	2113944F60	CAP,FXD,56PF,+5%,-5%,50V-DC,0805,C0G,-55DEG C
C157	2116069H05	CHIP CAPACITOR-EPP PART
C158	2113951A36	CAP NPO 12.0PF +/-5% 250V HI FREQ
C159	NOTPLACED	
C160	2103689A47	SL240J HIGH - Q CAPACITOR, UCNO
C161	NOTPLACED	
C169	NOTPLACED	
C170	2113944C45	CAP CER CHP 100.0PF 50V 5%
C171	2113944C45	CAP CER CHP 100.0PF 50V 5%
C172	2113951C12	CAP,FXD,1.2PF,.05PF+/-,250V-DC,0603,C0G,-55DE
C173	2113944C13	CAP CER CHP 2.0PF 50V +/- 0.25PF
C174	2113944C15	CAP CER CHP 2.4PF 50V +/- 0.25PF
C175	2113944C70	CAP,FXD,5.1PF,.25PF+/-,50V-DC,0603,C0G,-55DEG
C176	2113944C29	CAP CER CHP 9.1PF 50V +/- 0.5PF

ITEM	MOTOROLA PART NUMBER	DESCRIPTION
C177	2113944C22	CAP CER CHP 4.7PF 50V +/- 0.25PF
C178	2113944A18	CAP CER CHP 5.1PF 50V +/- 0.5PF
C179	2113944A40	CAP CER CHP 100.0PF 50V 5%
C182	2113944A40	CAP CER CHP 100.0PF 50V 5%
C185	2113945B02	CAP CER CHP 10,000PF 25V 10%
C186	NOTPLACED	
C187	2113944A40	CAP CER CHP 100.0PF 50V 5%
C188	2113944A40	CAP CER CHP 100.0PF 50V 5%
C189	2113944A40	CAP CER CHP 100.0PF 50V 5%
C191	NOTPLACED	
C192	2113944C21	CAP CER CHP 4.3PF 50V +/- 0.25PF
C193	NOTPLACED	
C200	2113945A13	CAP CER CHP 4700PF 50V 10%
C201	2185419D06	CAP CER SUPER L/D 0.1UF
C202	2113945C27	CAP,FXD,.047UF,+10%,-10%,50V-DC,0603,X7R,-55D
C203	2113945C27	CAP,FXD,.047UF,+10%,-10%,50V-DC,0603,X7R,-55D
C204	2109720D20	CAP CHIP LOW DIST 2000 SOV
C206	2113946K02	CAP CER CHP 0.10UF 16V
C207	2113946K02	CAP CER CHP 0.10UF 16V
C208	2113946K02	CAP CER CHP 0.10UF 16V
C209	2113946K02	CAP CER CHP 0.10UF 16V
C210	2313960D07	CAP,FXD,10,+10,-10,16,SM,-55MIN,125MAX,174,
C213	2113946K02	CAP CER CHP 0.10UF 16V
C214	2113945B02	CAP CER CHP 10,000PF 25V 10%
C215	2113944A40	CAP CER CHP 100.0PF 50V 5%
C217	2113944A40	CAP CER CHP 100.0PF 50V 5%
C218	2113946K02	CAP CER CHP 0.10UF 16V

ITEM	MOTOROLA PART NUMBER	DESCRIPTION
C219	2313960D07	CAP,FXD,10,+10,-10,16,SM,-55MIN,125MAX,174,
C220	2113945B02	CAP CER CHP 10,000PF 25V 10%
C221	2113944A40	CAP CER CHP 100.0PF 50V 5%
C222	2313960D07	CAP,FXD,10,+10,-10,16,SM,-55MIN,125MAX,174,
C226	2113945C31	CAP,FXD,.1UF,+10%,-10%,50V-DC,0603,X7R,-55DEG
C227	2113944C45	CAP CER CHP 100.0PF 50V 5%
C228	2113945C31	CAP,FXD,.1UF,+10%,-10%,50V-DC,0603,X7R,-55DEG
C229	2113945C31	CAP,FXD,.1UF,+10%,-10%,50V-DC,0603,X7R,-55DEG
C230	2113946K02	CAP CER CHP 0.10UF 16V
C231	2113945A01	CAP CER CHP 220PF 50V 10,
C232	2113946K02	CAP CER CHP 0.10UF 16V
C233	2113946K02	CAP CER CHP 0.10UF 16V
C234	2113944A40	CAP CER CHP 100.0PF 50V 5%
C235	2113944A40	CAP CER CHP 100.0PF 50V 5%
C236	2185419D06	CAP CER SUPER L/D 0.1UF
C237	2185419D06	CAP CER SUPER L/D 0.1UF
C238	2185419D06	CAP CER SUPER L/D 0.1UF
C239	2185419D06	CAP CER SUPER L/D 0.1UF
C240	2185419D06	CAP CER SUPER L/D 0.1UF
C241	2113944A40	CAP CER CHP 100.0PF 50V 5%
C242	2113944A40	CAP CER CHP 100.0PF 50V 5%
C243	2113946K02	CAP CER CHP 0.10UF 16V
C244	2113946B04	CAP CER CHP 0.10UF 10V 10%
C245	2113944A40	CAP CER CHP 100.0PF 50V 5%
C246	2113946N03	CAP CER CHP 2.2UF 16V
C247	2113945A09	CAP CER CHP 1000PF 50V 10%
C248	NOTPLACED	
C249	2113945A09	CAP CER CHP 1000PF 50V 10%

ITEM	MOTOROLA PART NUMBER	DESCRIPTION
C251	2113944M16	CAP,FXD,8.2PF,.1PF+/-,50V-DC,0603,C0G,-55DEG
C252	2113944M17	CAP,FXD,9.1PF,.1PF+/-,50V-DC,0603,C0G,-55DEG
C253	2113944A12	CAP CER CHP 3.0PF 50V +/- 0.25PF
C254	2113946B04	CAP CER CHP 0.10UF 10V 10%
C255	2113944A40	CAP CER CHP 100.0PF 50V 5%
C256	2113944M18	CAP,FXD,10PF,+2.5%,-2.5%,50V-DC,0603,C0G,-55D
C257	2113944M20	CAP,FXD,12PF,+2%,-2%,50V-DC,0603,C0G,-55DEG C
C258	2113944M17	CAP,FXD,9.1PF,.1PF+/-,50V-DC,0603,C0G,-55DEG
C259	2113944M35	CAP,FXD,51PF,+2%,-2%,50V-DC,0603,C0G,-55DEG C
C260	2113944A08	CAP CER CHP 2.0PF 50V +/- 0.25PF
C261	2113944A40	CAP CER CHP 100.0PF 50V 5%
C262	2113946B04	CAP CER CHP 0.10UF 10V 10%
C263	2113944A40	CAP CER CHP 100.0PF 50V 5%
C264	2113944A19	CAP CER CHP 5.6PF 50V +/- 0.5PF
C265	2113944A40	CAP CER CHP 100.0PF 50V 5%
C266	2113944A40	CAP CER CHP 100.0PF 50V 5%
C267	2113944A81	CAP,FXD,24PF,+5%,-5%,50V-DC,0402,C0G,-55DEG C
C268	2113944A27	CAP CER CHP 15.0PF 50V 5%
C269	2113946B04	CAP CER CHP 0.10UF 10V 10%
C271	2113944M15	CAP,FXD,7.5PF,.1PF+/-,50V-DC,0603,C0G,-55DEG
C272	2113944M15	CAP,FXD,7.5PF,.1PF+/-,50V-DC,0603,C0G,-55DEG
C273	2113944A14	CAP CER CHP 3.6PF 50V +/- 0.25PF
C274	2113944M14	CAP,FXD,6.8PF,.1PF+/-,50V-DC,0603,C0G,-55DEG

ITEM	MOTOROLA PART NUMBER	DESCRIPTION
C275	2113944M20	CAP,FXD,12PF,+2%,-2%,50V-DC,0603,C0G,-55DEG C
C276	2113944M16	CAP,FXD,8.2PF,.1PF+/-,50V-DC,0603,C0G,-55DEG
C277	2113944M35	CAP,FXD,51PF,+2%,-2%,50V-DC,0603,C0G,-55DEG C
C278	2113944A40	CAP CER CHP 100.0PF 50V 5%
C279	2113946B04	CAP CER CHP 0.10UF 10V 10%
C280	2113944A40	CAP CER CHP 100.0PF 50V 5%
C281	2113944A40	CAP CER CHP 100.0PF 50V 5%
C282	2113944A08	CAP CER CHP 2.0PF 50V +/- 0.25PF
C283	2113946B04	CAP CER CHP 0.10UF 10V 10%
C284	2113944A40	CAP CER CHP 100.0PF 50V 5%
C285	2113944A05	CAP CER CHP 1.5PF 50V +/- 0.25PF
C286	2113944A40	CAP CER CHP 100.0PF 50V 5%
C287	2113944A40	CAP CER CHP 100.0PF 50V 5%
C288	2113944A21	CAP CER CHP 6.8PF 50V +/- 0.5PF
C289	2113944A24	CAP CER CHP 9.1PF 50V +/- 0.5PF
C290	2113944A22	CAP CER CHP 7.5PF 50V +/- 0.5PF
C291	2113944A40	CAP CER CHP 100.0PF 50V 5%
C292	2113946B04	CAP CER CHP 0.10UF 10V 10%
C293	2113944A22	CAP CER CHP 7.5PF 50V +/- 0.5PF
C294	2113944A28	CAP CER CHP 18.0PF 50V 5%
C295	2113944A40	CAP CER CHP 100.0PF 50V 5%
C400	2113944A40	CAP CER CHP 100.0PF 50V 5%
C401	2113946K02	CAP CER CHP 0.10UF 16V
C405	2113944A40	CAP CER CHP 100.0PF 50V 5%
C411	2113945A11	CAP CER CHP 2200PF 50V 10%
C412	NOTPLACED	

ITEM	MOTOROLA PART NUMBER	DESCRIPTION	ITEM	MOTOROLA PART NUMBER	DESCRIPTION	ITEM	MOTOROLA PART NUMBER	DESCRIPTION	ITEM	MOTOROLA PART NUMBER	DESCRIPTION
C416	2113946K02	CAP CER CHP 0.10UF 16V	C463	2113945C27	CAP,FXD,.047UF,+10%,-10%,50V-DC,0603,X7R,-55D	C511	2113946K02	CAP CER CHP 0.10UF 16V	C614	2113945A03	CAP CER CHP 330PF 50V 10%
C417	2113944A40	CAP CER CHP 100.0PF 50V 5%	C464	2113946K02	CAP CER CHP 0.10UF 16V	C512	2113946K02	CAP CER CHP 0.10UF 16V	C615	2113944A32	CAP CER CHP 39.0PF 50V 5%
C421	NOTPLACED		C465	2113946K02	CAP CER CHP 0.10UF 16V	C513	2113955E37	CAP,FXD,10UF,+10%,-10%,16V-DC,1210,X7R,-55DEG	C617	2113944A32	CAP CER CHP 39.0PF 50V 5%
C422	2113945B02	CAP CER CHP 10,000PF 25V 10%	C470	2113946K02	CAP CER CHP 0.10UF 16V	C514	2113955E37	CAP,FXD,10UF,+10%,-10%,16V-DC,1210,X7R,-55DEG	C619	2113944A32	CAP CER CHP 39.0PF 50V 5%
C423	2113944C41	CAP CER CHP 68.0PF 50V 5%	C472	2113946K02	CAP CER CHP 0.10UF 16V	C516	2113946E02	CAP CER CHP 1.0UF 16V 10%	C620	2113945C31	CAP,FXD,.1UF,+10%,-10%,50V-DC,0603,X7R,-55DEG
C424	2113944A40	CAP CER CHP 100.0PF 50V 5%	C473	2113946K02	CAP CER CHP 0.10UF 16V	C517	2113946E02	CAP CER CHP 1.0UF 16V 10%	C621	2113946K02	CAP CER CHP 0.10UF 16V
C425	2113945H69	CAP,FXD,.1UF,+5%,-5%,50V-DC,1206,X7R,-55DEG C	C475	NOTPLACED		C518	2313960B57	CAP,FXD,10UF,+10%,-10%,6.3V-DC,SM,-55DEG CMIN	C629	2113944A32	CAP CER CHP 39.0PF 50V 5%
C428	2113945B02	CAP CER CHP 10,000PF 25V 10%	C476	2113944C89	CAP,FXD,200PF,+5%,-5%,50V-DC,0603,C0G,-55DEG	C520	2113944A40	CAP CER CHP 100.0PF 50V 5%	C630	2113944A32	CAP CER CHP 39.0PF 50V 5%
C429	2113946K02	CAP CER CHP 0.10UF 16V	C478	2113945C27	CAP,FXD,.047UF,+10%,-10%,50V-DC,0603,X7R,-55D	C521	2113945B02	CAP CER CHP 10,000PF 25V 10%	C631	2113944A32	CAP CER CHP 39.0PF 50V 5%
C430	2113946K02	CAP CER CHP 0.10UF 16V	C480	2313960M26	CAP,FXD,1UF,+10%,-10%,10V-DC,SM,-55DEG CMIN,	C522	2113945B02	CAP CER CHP 10,000PF 25V 10%	C632	2113944A32	CAP CER CHP 39.0PF 50V 5%
C431	2113946K02	CAP CER CHP 0.10UF 16V	C481	2313960B30	CAP,FXD,4.7UF,+10%,-10%,10V-DC,SM,-55DEG CMIN	C523	2113945B02	CAP CER CHP 10,000PF 25V 10%	C633	2113944A32	CAP CER CHP 39.0PF 50V 5%
C432	2113946K02	CAP CER CHP 0.10UF 16V	C482	2313960B30	CAP,FXD,4.7UF,+10%,-10%,10V-DC,SM,-55DEG CMIN	C524	2313960G32	CAP,FXD,10UF,+10%,-10%,35V-DC,SM,-55DEG CMIN	C634	2113944A32	CAP CER CHP 39.0PF 50V 5%
C433	2113944C33	CAP CER CHP 18.0PF 50V 5%	C500	2113945A58	CAP,FXD,910PF,+10%,-10%,50V-DC,0402,X7R,-55DE	C525	2113945A58	CAP,FXD,910PF,+10%,-10%,50V-DC,0402,X7R,-55DE	C635	2113944A32	CAP CER CHP 39.0PF 50V 5%
C434	2113945C27	CAP,FXD,.047UF,+10%,-10%,50V-DC,0603,X7R,-55D	C501	2113945A58	CAP,FXD,910PF,+10%,-10%,50V-DC,0402,X7R,-55DE	C526	2113945A58	CAP,FXD,910PF,+10%,-10%,50V-DC,0402,X7R,-55DE	C636	2113944A32	CAP CER CHP 39.0PF 50V 5%
C435	2113944A34	CAP CER CHP 56.0PF 50V 5%	C502	2113945A58	CAP,FXD,910PF,+10%,-10%,50V-DC,0402,X7R,-55DE	C527	2113945A58	CAP,FXD,910PF,+10%,-10%,50V-DC,0402,X7R,-55DE	C637	2113945L49	CAP,FXD,.01UF,+5%,-5%,50V-DC,0603,X7R,-55DEG
C436	2113944A34	CAP CER CHP 56.0PF 50V 5%	C503	2113945A58	CAP,FXD,910PF,+10%,-10%,50V-DC,0402,X7R,-55DE	C528	2113944A40	CAP CER CHP 100.0PF 50V 5%	C638	2113945C31	CAP,FXD,.1UF,+10%,-10%,50V-DC,0603,X7R,-55DEG
C437	2113944C72	CAP,FXD,6.2PF,.25PF+/-,50V-DC,0603,C0G,-55DEG	C504	2113944A40	CAP CER CHP 100.0PF 50V 5%	C529	NOTPLACED		C640	NOTPLACED	
C438	2113944C79	CAP,FXD,16PF,+5%,-5%,50V-DC,0603,C0G,-55DEG C	C505	2113945G98	CAP,FXD,.47UF,+10%,-10%,50V-DC,0805,X7R,-55DE	C550	2113945B02	CAP CER CHP 10,000PF 25V 10%	C641	NOTPLACED	
C440	2113945G96	CAP,FXD,.33UF,+10%,-10%,50V-DC,0805,X7R,-55DE	C506	2113946E02	CAP CER CHP 1.0UF 16V 10%	C551	2113945B02	CAP CER CHP 10,000PF 25V 10%	C652	2113944A40	CAP CER CHP 100.0PF 50V 5%
C441	2313960M26	CAP,FXD,1UF,+10%,-10%,10V-DC,SM,-55DEG CMIN,	C507	2113945B02	CAP CER CHP 10,000PF 25V 10%	C607	2113946K02	CAP CER CHP 0.10UF 16V	C653	2113944A36	CAP CER CHP 68.0PF 50V 5%
C442	2113945B02	CAP CER CHP 10,000PF 25V 10%	C508	2113945B02	CAP CER CHP 10,000PF 25V 10%	C610	2113944A32	CAP CER CHP 39.0PF 50V 5%	C654	2113944A36	CAP CER CHP 68.0PF 50V 5%
C447	NOTPLACED		C509	2113945B02	CAP CER CHP 10,000PF 25V 10%	C611	2113944A32	CAP CER CHP 39.0PF 50V 5%	C655	2113944A40	CAP CER CHP 100.0PF 50V 5%
C448	2113945C25	CAP,FXD,.033UF,+10%,-10%,50V-DC,0603,X7R,-55D	C510	2113946K02	CAP CER CHP 0.10UF 16V	C612	2113944A32	CAP CER CHP 39.0PF 50V 5%	C656	2113944A36	CAP CER CHP 68.0PF 50V 5%
C449	2113944A23	CAP CER CHP 8.2PF 50V +/-0.5PF				C613	2113944A32	CAP CER CHP 39.0PF 50V 5%	C657	2113944A36	CAP CER CHP 68.0PF 50V 5%
C461	2113946K02	CAP CER CHP 0.10UF 16V							C658	2113944A40	CAP CER CHP 100.0PF 50V 5%
									C671	2113944A31	CAP CER CHP 33.0PF 50V 5%
									C672	2113944A40	CAP CER CHP 100.0PF 50V 5%
									C673	2113944A31	CAP CER CHP 33.0PF 50V 5%
									C674	2113945A05	CAP CER CHP 470PF 50V 10%
									C675	2113944A40	CAP CER CHP 100.0PF 50V 5%

ITEM	MOTOROLA PART NUMBER	DESCRIPTION
C680	2113944A31	CAP CER CHP 33.0PF 50V 5%
C700	2113946B04	CAP CER CHP 0.10UF 10V 10%
C701	2113944A19	CAP CER CHP 5.6PF 50V +/- 0.5PF
C702	2113944A19	CAP CER CHP 5.6PF 50V +/- 0.5PF
C703	NOTPLACED	
C704	2113946F01	CAP CER CHP 2.2UF 6.3V 10%
C705	2113946F01	CAP CER CHP 2.2UF 6.3V 10%
C706	2113945A09	CAP CER CHP 1000PF 50V 10%
C707	NOTPLACED	
C708	2113944A31	CAP CER CHP 33.0PF 50V 5%
C709	2113944A31	CAP CER CHP 33.0PF 50V 5%
C710	2113946J03	CAP CER CHP 10.0UF 16V 10%
C711	2113946F01	CAP CER CHP 2.2UF 6.3V 10%
C712	2113946E02	CAP CER CHP 1.0UF 16V 10%
C713	2314030F31	CAP,FXD,68UF,+10%,-10%,10V-DC,SM,-55DEG CMIN,
C714	2113945A09	CAP CER CHP 1000PF 50V 10%
C715	2314030F03	CAP,FXD,22UF,+10%,-10%,16V-DC,SM,-55DEG CMIN,
C716	2113946F01	CAP CER CHP 2.2UF 6.3V 10%
C717	2113946E02	CAP CER CHP 1.0UF 16V 10%
C718	2113946F01	CAP CER CHP 2.2UF 6.3V 10%
C719	2113946E02	CAP CER CHP 1.0UF 16V 10%
C720	2113946G01	CAP CER CHP 2.2UF 16V 10%
C721	2113946E02	CAP CER CHP 1.0UF 16V 10%
C722	2113946E02	CAP CER CHP 1.0UF 16V 10%
C723	2113946E02	CAP CER CHP 1.0UF 16V 10%
C724	2113946E02	CAP CER CHP 1.0UF 16V 10%
C725	2113946K02	CAP CER CHP 0.10UF 16V
C726	2113944F07	CAP,CHIP,1000PF,+5%,-5%,50V-DC,0805,C0G,-55DE

ITEM	MOTOROLA PART NUMBER	DESCRIPTION
C727	2113944A40	CAP CER CHP 100.0PF 50V 5%
C728	2113944A40	CAP CER CHP 100.0PF 50V 5%
C729	2314030V05	CAP,FXD,47UF,+10%,-10%,16V-DC,SM,-55DEG CMIN,
C730	2113944A40	CAP CER CHP 100.0PF 50V 5%
C731	2113946G01	CAP CER CHP 2.2UF 16V 10%
C732	2113944A40	CAP CER CHP 100.0PF 50V 5%
C734	2113945C31	CAP,FXD,.1UF,+10%,-10%,50V-DC,0603,X7R,-55DEG
C735	2113946E02	CAP CER CHP 1.0UF 16V 10%
C736	2113946J03	CAP CER CHP 10.0UF 16V 10%
C737	2113945C31	CAP,FXD,.1UF,+10%,-10%,50V-DC,0603,X7R,-55DEG
C738	2113946K02	CAP CER CHP 0.10UF 16V
C742	2113945A05	CAP CER CHP 470PF 50V 10%
C743	2113944A25	CAP CER CHP 10.0PF 50V +/- 0.5PF
C750	2113946J03	CAP CER CHP 10.0UF 16V 10%
C751	2113946J03	CAP CER CHP 10.0UF 16V 10%
C752	2113944A40	CAP CER CHP 100.0PF 50V 5%
C753	2113944A40	CAP CER CHP 100.0PF 50V 5%
C754	2113946E02	CAP CER CHP 1.0UF 16V 10%
C755	2113946E02	CAP CER CHP 1.0UF 16V 10%
C756	2113944A40	CAP CER CHP 100.0PF 50V 5%
C757	2113944A40	CAP CER CHP 100.0PF 50V 5%
C758	2113946E02	CAP CER CHP 1.0UF 16V 10%
C759	2113946E02	CAP CER CHP 1.0UF 16V 10%
C760	2113944A40	CAP CER CHP 100.0PF 50V 5%
C761	2113944A40	CAP CER CHP 100.0PF 50V 5%
C762	2113945C31	CAP,FXD,.1UF,+10%,-10%,50V-DC,0603,X7R,-55DEG
C763	2113944A40	CAP CER CHP 100.0PF 50V 5%
C764	2113946B03	CAP CER CHP 0.068UF 10V 10

ITEM	MOTOROLA PART NUMBER	DESCRIPTION
C765	2113946B03	CAP CER CHP 0.068UF 10V 10
C766	2113945A03	CAP CER CHP 330PF 50V 10%
C767	2113945A03	CAP CER CHP 330PF 50V 10%
C768	2113945A03	CAP CER CHP 330PF 50V 10%
C769	2113945A03	CAP CER CHP 330PF 50V 10%
C770	2113945C31	CAP,FXD,.1UF,+10%,-10%,50V-DC,0603,X7R,-55DEG
C771	2113945C31	CAP,FXD,.1UF,+10%,-10%,50V-DC,0603,X7R,-55DEG
C773	2113946K02	CAP CER CHP 0.10UF 16V
C790	2113946A02	CAP CER CHP 0.022UF 16V 10,
C791	2113946K02	CAP CER CHP 0.10UF 16V
C792	2113946K02	CAP CER CHP 0.10UF 16V
C796	2113944A40	CAP CER CHP 100.0PF 50V 5%
C800	2113955D31	CAP,FXD,1UF,+10%,-10%,16V-DC,1206,X7R,-55DEG
CR800	4813978A25	SCHOTTKY 30V SOD-323 T&R PB FREE
C801	2113944A40	CAP CER CHP 100.0PF 50V 5%
CR801	4813978A25	SCHOTTKY 30V SOD-323 T&R PB FREE
C802	2113945C20	CAP,FXD,.016UF,+10%,-10%,50V-DC,0603,X7R,-55
C803	2113944A40	CAP CER CHP 100.0PF 50V 5%
C804	2113946E02	CAP CER CHP 1.0UF 16V 10%
C805	2113945C20	CAP,FXD,.016UF,+10%,-10%,50V-DC,0603,X7R,-55
C806	2113946K02	CAP CER CHP 0.10UF 16V
C807	2113946K02	CAP CER CHP 0.10UF 16V
C808	2113946K02	CAP CER CHP 0.10UF 16V
C809	2113945C20	CAP,FXD,.016UF,+10%,-10%,50V-DC,0603,X7R,-55
C810	2113946E02	CAP CER CHP 1.0UF 16V 10%
C811	2113946K02	CAP CER CHP 0.10UF 16V
C812	2113946K02	CAP CER CHP 0.10UF 16V

ITEM	MOTOROLA PART NUMBER	DESCRIPTION
C813	2113946K02	CAP CER CHP 0.10UF 16V
C814	2113946K02	CAP CER CHP 0.10UF 16V
C815	2113946K02	CAP CER CHP 0.10UF 16V
C816	2113946K02	CAP CER CHP 0.10UF 16V
C817	2113946K02	CAP CER CHP 0.10UF 16V
C818	2113946K02	CAP CER CHP 0.10UF 16V
C830	2113946K02	CAP CER CHP 0.10UF 16V
C840	2113946F03	CAP CER CHP 4.7UF 6.3V 10%
C850	2113945A03	CAP CER CHP 330PF 50V 10%
C851	2113944A40	CAP CER CHP 100.0PF 50V 5%
C855	NOTPLACED	
C856	NOTPLACED	
C857	NOTPLACED	
C858	2113945B02	CAP CER CHP 10,000PF 25V 10%
C859	2113945B02	CAP CER CHP 10,000PF 25V 10%
C860	2113945B02	CAP CER CHP 10,000PF 25V 10%
C861	2113945B02	CAP CER CHP 10,000PF 25V 10%
C862	2113945B02	CAP CER CHP 10,000PF 25V 10%
C863	2113945B02	CAP CER CHP 10,000PF 25V 10%
C864	2113945B02	CAP CER CHP 10,000PF 25V 10%
C865	2113945B02	CAP CER CHP 10,000PF 25V 10%
C866	2113945B02	CAP CER CHP 10,000PF 25V 10%
C867	NOTPLACED	
C868	NOTPLACED	
D3	4815096H01	VARACTOR DIODE 1SV305
D5	4815096H01	VARACTOR DIODE 1SV305

ITEM	MOTOROLA PART NUMBER	DESCRIPTION
D10	4815096H01	VARACTOR DIODE 1SV305
D12	4815096H01	VARACTOR DIODE 1SV305
D20	4813974A19	DIODE ARRAY,MXR,SM,SOT-323,7V,.2W,SHTK,2,PB-F
D170	4802482J02	PIN DIODE SMD
D171	4802482J02	PIN DIODE SMD
D172	4813978A26	DIODE ARRAY,DET,SOT-363/SC-88,30V,.12W,2
D173	4813978A26	DIODE ARRAY,DET,SOT-363/SC-88,30V,.12W,2
D201	4815011H01	DIODE TRIPLE
D202	4815011H01	DIODE TRIPLE
D251	4815002H01	VARACTOR DIODE
D252	4815002H01	VARACTOR DIODE
D253	4815002H01	VARACTOR DIODE
D254	4815002H01	VARACTOR DIODE
D271	4815002H01	VARACTOR DIODE
D272	4815002H01	VARACTOR DIODE
D273	4815002H01	VARACTOR DIODE
D274	4815002H01	VARACTOR DIODE
D401	4805656W87	DIODE,VCTR, @ 15V,1SV279,SOD-523/SC-79
D402	4815096H01	VARACTOR DIODE 1SV305
D403	4815096H01	VARACTOR DIODE 1SV305
D500	4815155H01	RECTIFIER
D501	4809118D02	LED BICOLOR LNJ115W8POMT
D510	4813978M15	DIODE,RECT,1A,40V,PB-FREE, NOTCOMPLETELY
D511	4813978B18	DIODE,SWG,BAT54,SM,SOT-23,200MA,30V,.2W,SHTK,
D512	4813978M15	DIODE,RECT,1A,40V,PB-FREE, NOTCOMPLETELY
D513	4813978M15	DIODE,RECT,1A,40V,PB-FREE, NOTCOMPLETELY

ITEM	MOTOROLA PART NUMBER	DESCRIPTION
D600	4813978B18	DIODE,SWG,BAT54,SM,SOT-23,200MA,30V,.2W,SHTK,
D603	4813978A25	SCHOTTKY 30V SOD-323 T&R PB FREE
D662	4813978A25	SCHOTTKY 30V SOD-323 T&R PB FREE
D700	4813978B18	DIODE,SWG,BAT54,SM,SOT-23,200MA,30V,.2W,SHTK,
E102	2480574F01	IND FERRITE CHIP 60OHM 0603
E140	2405688Z01	INDUCTOR FERRITE BEAD
E141	2480640Z01	SURFACE MOUNT FERRITE BEAD
E402	2480640Z01	SURFACE MOUNT FERRITE BEAD
E406	2414032B76	IDCTR,WW,4.7UH,5%,330MA,40HM,CER,20 Q,60MH
E800	2480574F01	IND FERRITE CHIP 60OHM 0603
E801	2480574F01	IND FERRITE CHIP 60OHM 0603
E802	0613952G67	CER CHIP RES 0.0 +/-0.050 OHM
FL51	9185924B01	FILTER, 73.35 MHZ 3-POLE CRYST
FL200	9116848H01	FLTR SW CAP 3 POLE BUTTERW, W18
F500	6515076H01	FUSE CHIP SMT TR/1608FF 3A
J101	2880658Z08	CONNECTOR SMA
J601	0916287H01	CONN VERT 45 PIN ZIF
J650	0916287H02	CONN 20 PIN ZIF
L5	2460591C16	COIL AIR WOUND INDUC 16.28
L12	2460591C16	COIL AIR WOUND INDUC 16.28
L31	2414017P13	IDCTR,CHIP,10NH,5%,300MA,.46 OHM,CER,9 Q,2.5GH
L33	2415429H36	CHIP INDUCTOR
L34	2415429H36	CHIP INDUCTOR
L42	2460591C16	COIL AIR WOUND INDUC 16.28
L49	2460591C16	COIL AIR WOUND INDUC 16.28
L53	2415429H43	CHIP INDUCTOR

ITEM	MOTOROLA PART NUMBER	DESCRIPTION
L54	2414017K32	IDCTR,CHIP,560NH,5%,50MA,50HM,CER,11Q,150MHZS
L55	2414032D25	IDCTR,WW,620NH,5%,400MA,1.60HM,CER,28Q,400MHZ
L57	2414017P12	IDCTR,CHIP,8.2NH,5%,300MA,.390HM,CER,9 Q,2.8G
L61	2415429H39	CHIP INDUCTOR
L63	2414017P17	IDCTR,CHIP,22NH,5%,300MA,.88 OHM,CER,9 Q,1.8GH
L69	2415429H38	CHIP INDUCTOR
L71	2414017P16	IDCTR,CHIP,18NH,5%,300MA,.76 OHM,CER,9 Q,1.9GH
L72	2415429H38	CHIP INDUCTOR
L73	2415429H47	CHIP INDUCTOR
L74	2414017P17	IDCTR,CHIP,22NH,5%,300MA,.88 OHM,CER,9 Q,1.8GH
L106	2414032D30	IDCTR,WW,1UH,5%,320MA,2.80HM,CER,28 Q,340MHZ
L114	2414032B56	IDCTR,WW,180NH,5%,750MA,.770HM,CER,25 Q,700MH
L119	2460591C35	COIL AIR WOUND INDUC 18.08
L120	2414017G09	IDCTR,CHIP,15NH,5%,300MA,.45 OHM,CER,8Q,SM
L121	NOTPLACED	
L128	2414032D30	IDCTR,WW,1UH,5%,320MA,2.80HM,CER,28 Q,340MHZ
L130	2414017G09	IDCTR,CHIP,15NH,5%,300MA,.45 OHM,CER,8Q,SM
L131	2414017G01	IDCTR,CHIP,3.3NH,300MA,.22OHM,CER,8Q,SM,
L132	NOTPLACED	
L134	2414017G03	IDCTR,CHIP,4.7NH,300MA,.28OHM,CER,8 Q,SM,0603
L139	2460591A29	COIL AIR WOUND INDUC 6.61
L171	2460591B80	COIL AIR WOUND INDUC 19.61
L172	2460591B80	COIL AIR WOUND INDUC 19.61
L173	2460591B80	COIL AIR WOUND INDUC 19.61

ITEM	MOTOROLA PART NUMBER	DESCRIPTION
L176	2460591D24	COIL AIR WOUND INDUC 19.71
L200	2414017Q47	IDCTR,FXD,1UH,10%,50MA,.450HM,FERR,45 Q,75MHZ
L201	2414017Q20	IDCTR,FXD,2.2UH,20%,30MA,.65 OHM,FERR,45Q,50MH
L202	2414017Q20	IDCTR,FXD,2.2UH,20%,30MA,.65 OHM,FERR,45Q,50MH
L203	2414017Q20	IDCTR,FXD,2.2UH,20%,30MA,.65 OHM,FERR,45Q,50MH
L204	2414017Q20	IDCTR,FXD,2.2UH,20%,30MA,.65 OHM,FERR,45Q,50MH
L205	2414017Q47	IDCTR,FXD,1UH,10%,50MA,.450HM,FERR,45 Q,75MHZ
L206	2414017Q20	IDCTR,FXD,2.2UH,20%,30MA,.65 OHM,FERR,45Q,50MH
L251	2414032F41	IDCTR,WW,390NH,10%,200MA,1.50HM,CER,40 Q,730M
L252	2415427H37	CHIP INDUCTOR
L253	2415010H04	AIRWOUND COIL
L254	2414032F41	IDCTR,WW,390NH,10%,200MA,1.50HM,CER,40 Q,730M
L255	2414032F41	IDCTR,WW,390NH,10%,200MA,1.50HM,CER,40 Q,730M
L256	2414032F41	IDCTR,WW,390NH,10%,200MA,1.50HM,CER,40 Q,730M
L257	2414032F41	IDCTR,WW,390NH,10%,200MA,1.50HM,CER,40 Q,730M
L258	2415427H26	CHIP INDUCTOR
L270	2414032F41	IDCTR,WW,390NH,10%,200MA,1.50HM,CER,40 Q,730M
L271	2415427H37	CHIP INDUCTOR
L272	2415010H03	AIRWOUND COIL
L273	2414032F41	IDCTR,WW,390NH,10%,200MA,1.50HM,CER,40 Q,730M
L274	2414032F41	IDCTR,WW,390NH,10%,200MA,1.50HM,CER,40 Q,730M
L275	2414032F41	IDCTR,WW,390NH,10%,200MA,1.50HM,CER,40 Q,730M

ITEM	MOTOROLA PART NUMBER	DESCRIPTION
L276	2414032F41	IDCTR,WW,390NH,10%,200MA,1.50HM,CER,40 Q,730M
L277	2414017H17	IDCTR,CHIP,27NH,5%,300MA,.45 OHM,CER,12Q,1.1GH
L278	2414017P18	IDCTR,CHIP,27NH,5%,300MA,1.0 4OHM,CER,9 Q,1.5G
L279	2414017P18	IDCTR,CHIP,27NH,5%,300MA,1.0 4OHM,CER,9 Q,1.5G
L280	2414017Q47	IDCTR,FXD,1UH,10%,50MA,.450 HM,FERR,45 Q,75MHZ
L403	2414032B75	IDCTR,WW,3.9UH,5%,340MA,3.6 OHM,CER,20Q,70MHZS
L404	2414032B59	IDCTR,WW,330NH,5%,690MA,1.05OHM,CER,30Q,500MH
L407	2414032B76	IDCTR,WW,4.7UH,5%,330MA,4O HM,CER,20 Q,60MH
L411	2466505A01	COIL INDUCTOR
L412	2466505A01	COIL INDUCTOR
L413	2414032B59	IDCTR,WW,330NH,5%,690MA,1.05OHM,CER,30Q,500MH
L414	2414017Q51	IDCTR,FXD,2.2UH,10%,30MA,.65 OHM,FERR,45 Q,50M
L500	2414017Q42	IDCTR,FXD,390NH,10%,200MA,.65OHM,FERR,25Q,135
L501	2414017Q51	IDCTR,FXD,2.2UH,10%,30MA,.65 OHM,FERR,45 Q,50M
L502	2489669V01	IDCTR,WW,100UH,5%,40MA,10O HM,20 Q,10MHZ SRF,S
L651	2414032F75	IDCTR,WW,270NH,2%,350MA,1O HM,CER,48 Q,650MHZ
L652	2414032F75	IDCTR,WW,270NH,2%,350MA,1O HM,CER,48 Q,650MHZ
L701	2486085A01	COIL, POWER INDUCTOR
L702	2486085A01	COIL, POWER INDUCTOR
L703	2464675H01	IDCTR,WW,560NH,5%,550MA
L704	2464675H01	IDCTR,WW,560NH,5%,550MA
L705	2464675H01	IDCTR,WW,560NH,5%,550MA
L708	2416307H01	IDCTR,WW,680NH,5%,0603

ITEM	MOTOROLA PART NUMBER	DESCRIPTION
L710	2416307H01	IDCTR,WW,680NH,5%,0603
M501	NOTPLACED	
M701	0985888K02	SKT RTC BTTY LEAP
P4	3905643V01	CONTACT ANT GRD
P5	3916333H02	GROUND CONTACT
Q29	4805585Q19	TRANSISTOR
Q101	4816698H03	MITSUBISHI RD09MUP2-T112 UHF RFPA
Q197	4813973A13	XSTR,BIP GP SS,PNP,TO-236,SOT-23,SMT,40V,.
Q200	4871674S01	XSTR,BIP GP SS
Q251	4885061Y01	XSTR NPN 6V 30UA 12GHZ PB-FREE
Q252	4885061Y01	XSTR NPN 6V 30UA 12GHZ PB-FREE
Q253	4815055H01	TSTR DUAL NPN/PNP UMH 5
Q271	4885061Y01	XSTR NPN 6V 30UA 12GHZ PB-FREE
Q272	4885061Y01	XSTR NPN 6V 30UA 12GHZ PB-FREE
Q273	4815055H01	TSTR DUAL NPN/PNP UMH 5
Q401	4805585Q28	TRANSISTOR RF NPN 8GHZ NOPB
Q402	4813973A04	XSTR,BIP GP SS,NPN,TA13,SM,SOT-23,SMT,30V,.22
Q501	4805921T28	XSTR, DUAL NOPB
Q698	4813973A81	XSTR,BIP GP SS,DIG,NPN AND PNP,SOT-363,50V,.2
Q700	4813970A62	XSTR,FET GP PWR,MOSFET,P-CH,ENHN,CF,-20V,1.3W
Q701	4813973M07	XSTR,BIP GP SS,NPN,TO-236,SMT,40V,.225W,2
Q702	5185956E76	IC,CONV,SM,SO16,0-30 VINPUT RANGE,6.5A,3.8V
Q703	4813970A62	XSTR,FET GP PWR,MOSFET,P-CH,ENHN,CF,-20V,1.3W

ITEM	MOTOROLA PART NUMBER	DESCRIPTION
Q704	NOTPLACED	
Q705	NOTPLACED	
Q706	NOTPLACED	
Q709	4885061Y01	XSTR NPN 6V 30UA 12GHZ PB-FREE
Q801	4813973A42	XSTR,BIP GP SS,NPN,SM,SC-59,SMT,50V,.23W,
Q804	4813973A81	XSTR,BIP GP SS,DIG,NPN AND PNP,SOT-363,50V,.2
R13	0613952R01	CER CHIP RES 10K OHM 5% 0402
R14	0613952R01	CER CHIP RES 10K OHM 5% 0402
R24	0613952Q93	CER CHIP RES 6800 OHM 5 0402
R32	0613952Q70	CER CHIP RES 750 OHM 5 0402
R33	0613952R01	CER CHIP RES 10K OHM 5% 0402
R34	0613952R01	CER CHIP RES 10K OHM 5% 0402
R35	0613952R66	CER CHIP RES 0.0 +/-0.050 OHM
R36	0613952G67	CER CHIP RES 0.0 +/-0.050 OHM
R37	0613952R66	CER CHIP RES 0.0 +/-0.050 OHM
R38	0613958J74	CER CHIP RES 0.0 OHM JMP 0805
R51	0613952Q46	CER CHIP RES 75.0 OHM 5 0402
R60	0613952R25	CER CHIP RES 100K OHM 5% 0402
R61	0613952Q81	CER CHIP RES 2200 OHM 5 0402
R62	0613952Q81	CER CHIP RES 2200 OHM 5 0402
R63	0613952Q69	CER CHIP RES 680 OHM 5 0402
R102	0613952R05	CER CHIP RES 15K OHM 5% 0402
R103	0613952Q42	CER CHIP RES 51.0 OHM 5 0402
R104	0613952R06	CER CHIP RES 16K OHM 5 0402

ITEM	MOTOROLA PART NUMBER	DESCRIPTION
R108	0613952G67	CER CHIP RES 0.0 +/-0.050 OHM
R125	0613952H47	CER CHIP RES 82.0 OHM 5 0603
R127	0613952R01	CER CHIP RES 10K OHM 5% 0402
R130	0613952H53	CER CHIP RES 150 OHM 5% 0603
R142	0613952R14	CER CHIP RES 36K OHM 5 0402
R143	0613952Z64	RES,MF,39KOHM,1%,.0625W,SM ,0402,200PPM/CEL,FO
R144	0613952R25	CER CHIP RES 100K OHM 5% 0402
R146	0613952H73	CER CHIP RES 1000 OHM 5% 0603
R149	0613952Q89	CER CHIP RES 4700 OHM 5 0402
R150	0613952H47	CER CHIP RES 82.0 OHM 5 0603
R151	0613952H47	CER CHIP RES 82.0 OHM 5 0603
R153	NOTPLACED	
R154	0613952Q61	CER CHIP RES 330 OHM 5 0402
R155	0613952Q76	CER CHIP RES 1300 OHM 5 0402
R156	NOTPLACED	
R157	NOTPLACED	
R158	NOTPLACED	
R159	0613952Q25	CER CHIP RES 10.0 OHM 5 0402
R160	0613952R66	CER CHIP RES 0.0 +/-0.050 OHM
R162	NOTPLACED	
R168	0613952Q56	CER CHIP RES 200 OHM 5 0402
R169	0613952Q52	CER CHIP RES 130 OHM 5 0402
R170	0613952Q56	CER CHIP RES 200 OHM 5 0402
R171	0613952Q52	CER CHIP RES 130 OHM 5 0402
R199	0613952H73	CER CHIP RES 1000 OHM 5% 0603
R201	0613952Q51	CER CHIP RES 120 OHM 5 0402

ITEM	MOTOROLA PART NUMBER	DESCRIPTION
R202	0613952Q75	CER CHIP RES 1200 OHM 5 0402
R203	0613952Q63	CER CHIP RES 390 OHM 5 0402
R204	0613952R19	CER CHIP RES 56K OHM 5% 0402
R205	0613952R15	CER CHIP RES 39K OHM 5% 0402
R206	0613952R01	CER CHIP RES 10K OHM 5% 0402
R207	0613952Q73	CER CHIP RES 1000 OHM 5 0402
R208	0613952R13	CER CHIP RES 33K OHM 5% 0402
R209	0613952G67	CER CHIP RES 0.0 +/-0.050 OHM
R210	0613952R13	CER CHIP RES 33K OHM 5% 0402
R211	0613952Q80	CER CHIP RES 2000 OHM 5 0402
R212	NOTPLACED	
R213	0613952Q95	CER CHIP RES 8200 OHM 5 0402
R214	0613952Q73	CER CHIP RES 1000 OHM 5 0402
R215	0613952R01	CER CHIP RES 10K OHM 5% 0402
R216	0613952Q46 (PMLE2537A) 0613952K93 (PMLE2537D)	CER CHIP RES 75.0 OHM 5 0402 CER CHIP RES 91 OHM 5 0402
R217	0613952Q88	CER CHIP RES 4300 OHM 5 0402
R218	0613952Q93	CER CHIP RES 6800 OHM 5 0402
R248	0613952R66	CER CHIP RES 0.0 +/-0.050 OHM
R249	NOTPLACED	
R252	0613952Q93	CER CHIP RES 6800 OHM 5 0402

ITEM	MOTOROLA PART NUMBER	DESCRIPTION
R253	0613952Q96	CER CHIP RES 9100 OHM 5 0402
R256	0613952Q51	CER CHIP RES 120 OHM 5 0402
R257	0613952Q42	CER CHIP RES 51.0 OHM 5 0402
R260	0613952Q94	CER CHIP RES 7500 OHM 5 0402
R261	NOTPLACED	
R262	0613952Q91	CER CHIP RES 5600 OHM 5 0402
R263	0613952Q58	CER CHIP RES 240 OHM 5 0402
R265	0613952Q41	CER CHIP RES 47.0 OHM 5 0402
R266	0613952R66	CER CHIP RES 0.0 +/-0.050 OHM
R269	0613952R66	CER CHIP RES 0.0 +/-0.050 OHM
R270	0613952Q95	CER CHIP RES 8200 OHM 5 0402
R271	0613952Q93	CER CHIP RES 6800 OHM 5 0402
R272	0613952Q53	CER CHIP RES 150 OHM 5 0402
R277	NOTPLACED	
R278	0613952Q95	CER CHIP RES 8200 OHM 5 0402
R279	0613952Q88	CER CHIP RES 4300 OHM 5 0402
R280	0613952Q49	CER CHIP RES 100 OHM 5 0402
R284	0613952Q49	CER CHIP RES 100 OHM 5 0402
R285	0613952Q73	CER CHIP RES 1000 OHM 5 0402
R286	0613952R66	CER CHIP RES 0.0 +/-0.050 OHM
R287	NOTPLACED	
R288	0613952R66	CER CHIP RES 0.0 +/-0.050 OHM
R289	0613952R66	CER CHIP RES 0.0 +/-0.050 OHM
R290	0613952R66	CER CHIP RES 0.0 +/-0.050 OHM
R406	0613952R01	CER CHIP RES 10K OHM 5% 0402
R407	0613952R01	CER CHIP RES 10K OHM 5% 0402

ITEM	MOTOROLA PART NUMBER	DESCRIPTION
R408	0613952H79	CER CHIP RES 1800 OHM 5% 0603
R412	0613952H55	CER CHIP RES 180 OHM 5% 0603
R413	0613952H61	CER CHIP RES 330 OHM 5 0603
R414	0613952R01	CER CHIP RES 10K OHM 5% 0402
R415	0613952R01	CER CHIP RES 10K OHM 5% 0402
R417	0613952Q74	RES,MF,1.1KOHM,5%,.0625W,S M,0402,200PPM/CEL,P
R418	0613952R66	CER CHIP RES 0.0 +/-0.050 OHM
R419	0613952R25	CER CHIP RES 100K OHM 5% 0402
R420	0613952R19	CER CHIP RES 56K OHM 5% 0402
R436	0613952R66	CER CHIP RES 0.0 +/-0.050 OHM
R499	0613952R01	CER CHIP RES 10K OHM 5% 0402
R503	0613952Q63	CER CHIP RES 390 OHM 5 0402
R504	0613952Q66	CER CHIP RES 510 OHM 5 0402
R505	0613952R01 (PMLE2537A) 0613952Q93 (PMLE2537D)	CER CHIP RES 10K OHM 5% 0402 CER CHIP RES 6.8K OHM 5% 0402
R507	0613952Q49	CER CHIP RES 100 OHM 5 0402
R508	0613952Q49	CER CHIP RES 100 OHM 5 0402
R509	0613952Q49	CER CHIP RES 100 OHM 5 0402
R510	0613952Q49	CER CHIP RES 100 OHM 5 0402
R511	0613952R01	CER CHIP RES 10K OHM 5% 0402
R512	0613952R17	CER CHIP RES 47K OHM 5% 0402
R513	0613952R01	CER CHIP RES 10K OHM 5% 0402
R514	0613952R01	CER CHIP RES 10K OHM 5% 0402

ITEM	MOTOROLA PART NUMBER	DESCRIPTION
R515	0613952R01	CER CHIP RES 10K OHM 5% 0402
R516	0613952R01	CER CHIP RES 10K OHM 5% 0402
R517	0613952R01	CER CHIP RES 10K OHM 5% 0402
R518	0613952R01	CER CHIP RES 10K OHM 5% 0402
R519	0613952R17	CER CHIP RES 47K OHM 5% 0402
R520	0613952R37	CER CHIP RES 330K OHM 5% 0402
R521	NOTPLACED	
R522	0613952R17	CER CHIP RES 47K OHM 5% 0402
R523	0613952R17	CER CHIP RES 47K OHM 5% 0402
R524	0613952G67	CER CHIP RES 0.0 +/-0.050 OHM
R525	0613952R01	CER CHIP RES 10K OHM 5% 0402
R526	0613952R01	CER CHIP RES 10K OHM 5% 0402
R527	NOTPLACED	
R528	0613952G67	CER CHIP RES 0.0 +/-0.050 OHM
R608	0613952Q49	CER CHIP RES 100 OHM 5 0402
R610	NOTPLACED	
R611	0613952Q49	CER CHIP RES 100 OHM 5 0402
R613	0613952R08	CER CHIP RES 20K OHM 5 0402
R614	0613952R08	CER CHIP RES 20K OHM 5 0402
R615	0613952R25	CER CHIP RES 100K OHM 5% 0402
R616	0613952Q49	CER CHIP RES 100 OHM 5 0402
R617	NOTPLACED	
R620	0613952Q49	CER CHIP RES 100 OHM 5 0402
R621	0613952Q49	CER CHIP RES 100 OHM 5 0402
R622	0613952Q49	CER CHIP RES 100 OHM 5 0402

ITEM	MOTOROLA PART NUMBER	DESCRIPTION	ITEM	MOTOROLA PART NUMBER	DESCRIPTION	ITEM	MOTOROLA PART NUMBER	DESCRIPTION	ITEM	MOTOROLA PART NUMBER	DESCRIPTION
R625	0613952Q49	CER CHIP RES 100 OHM 5 0402	R670	0613952Q49	CER CHIP RES 100 OHM 5 0402	R729	0613952R13	CER CHIP RES 33K OHM 5% 0402	R768	NOTPLACED	
R626	0613952Q49	CER CHIP RES 100 OHM 5 0402	R671	0613952Q63	CER CHIP RES 390 OHM 5 0402	R740	0613952Q63	CER CHIP RES 390 OHM 5 0402	R771	NOTPLACED	
R633	NOTPLACED		R672	0613952R01	CER CHIP RES 10K OHM 5% 0402	R741	0613952R17	CER CHIP RES 47K OHM 5% 0402	R772	0613952Q49	CER CHIP RES 100 OHM 5 0402
R634	0613952R66	CER CHIP RES 0.0 +/-0.050 OHM	R673	0613952R01	CER CHIP RES 10K OHM 5% 0402	R742	0613952R17	CER CHIP RES 47K OHM 5% 0402	R773	0613952Q49	CER CHIP RES 100 OHM 5 0402
R635	NOTPLACED		R674	0613952Q49	CER CHIP RES 100 OHM 5 0402	R743	NOTPLACED		R774	0613952Q49	CER CHIP RES 100 OHM 5 0402
R636	0613952R01	CER CHIP RES 10K OHM 5% 0402	R675	0613952Q67	CER CHIP RES 560 OHM 5 0402	R744	NOTPLACED		R775	0613952Q49	CER CHIP RES 100 OHM 5 0402
R637	0613952Q73	CER CHIP RES 1000 OHM 5 0402	R677	0613952R01	CER CHIP RES 10K OHM 5% 0402	R745	0613952R56	CER CHIP RES 2.0M OHM 5 0402	R776	NOTPLACED	
R638	0613952Q73	CER CHIP RES 1000 OHM 5 0402	R678	0613952Q49	CER CHIP RES 100 OHM 5 0402	R746	0613952R56	CER CHIP RES 2.0M OHM 5 0402	R777	0613952R01	CER CHIP RES 10K OHM 5% 0402
R639	0613952Q73	CER CHIP RES 1000 OHM 5 0402	R697	0613952Q49	CER CHIP RES 100 OHM 5 0402	R747	0613952Q73	CER CHIP RES 1000 OHM 5 0402	R778	0613952R01	CER CHIP RES 10K OHM 5% 0402
R640	0613952Q73	CER CHIP RES 1000 OHM 5 0402	R700	0613952Q80	CER CHIP RES 2000 OHM 5 0402	R748	0613952R41	CER CHIP RES 470K OHM 5% 0402	R779	0613952R01	CER CHIP RES 10K OHM 5% 0402
R641	0613952Q73	CER CHIP RES 1000 OHM 5 0402	R701	0613952R17	CER CHIP RES 47K OHM 5% 0402	R749	0613952R41	CER CHIP RES 470K OHM 5% 0402	R780	0613952Q89	CER CHIP RES 4700 OHM 5 0402
R642	0613952Q73	CER CHIP RES 1000 OHM 5 0402	R702	0613952R66	CER CHIP RES 0.0 +/-0.050 OHM	R750	0613952Q63	CER CHIP RES 390 OHM 5 0402	R781	0613952R01	CER CHIP RES 10K OHM 5% 0402
R643	0613952Q73	CER CHIP RES 1000 OHM 5 0402	R703	0613952R17	CER CHIP RES 47K OHM 5% 0402	R751	0613952Q63	CER CHIP RES 390 OHM 5 0402	R782	0613952R01	CER CHIP RES 10K OHM 5% 0402
R644	0613952Q73	CER CHIP RES 1000 OHM 5 0402	R704	0613952Q49	CER CHIP RES 100 OHM 5 0402	R752	0613952Q81	CER CHIP RES 2200 OHM 5 0402	R783	0613952R01	CER CHIP RES 10K OHM 5% 0402
R647	0613952R01	CER CHIP RES 10K OHM 5% 0402	R705	0613952R17	CER CHIP RES 47K OHM 5% 0402	R753	0613952Q81	CER CHIP RES 2200 OHM 5 0402	R784	NOTPLACED	
R649	0613952R17	CER CHIP RES 47K OHM 5% 0402	R708	0613952R19	CER CHIP RES 56K OHM 5% 0402	R756	0613952R66	CER CHIP RES 0.0 +/-0.050 OHM	R785	0613952Q49	CER CHIP RES 100 OHM 5 0402
R654	0613952R01	CER CHIP RES 10K OHM 5% 0402	R709	0613952H17	CER CHIP RES 4.7OHM 5%	R757	0613952R08	CER CHIP RES 20K OHM 5 0402	R786	0613952R17	CER CHIP RES 47K OHM 5% 0402
R656	0613952R01	CER CHIP RES 10K OHM 5% 0402	R710	0688044N04	RES,METAL STRIP, 0.1 OHM,1%,0.125W,SMD,0805,7	R758	0613952R19	CER CHIP RES 56K OHM 5% 0402	R790	0613952R19	CER CHIP RES 56K OHM 5% 0402
R658	0613952P18	CER CHIP RES 150K OHM 1 0402	R711	0613952G67	CER CHIP RES 0.0 +/-0.050 OHM	R759	0613952R01	CER CHIP RES 10K OHM 5% 0402	R791	0613952R66	CER CHIP RES 0.0 +/-0.050 OHM
R666	0613952Q42	CER CHIP RES 51.0 OHM 5% 0402	R712	0613952Q49	CER CHIP RES 100 OHM 5 0402	R760	0613952Q93	CER CHIP RES 6800 OHM 5 0402	R792	0613952R66	CER CHIP RES 0.0 +/-0.050 OHM
R667	0613952Q63	CER CHIP RES 390 OHM 5 0402	R714	0688044N04	RES,METAL STRIP, 0.1 OHM,1%,0.125W,SMD,0805,7	R763	NOTPLACED		R793	0613952R66	CER CHIP RES 0.0 +/-0.050 OHM
R668	0613952Q45	CER CHIP RES 68.0 OHM 5 0402	R717	0613952R66	CER CHIP RES 0.0 +/-0.050 OHM	R764	NOTPLACED		R794	0613952R66	CER CHIP RES 0.0 +/-0.050 OHM
R669	0613952Q49	CER CHIP RES 100 OHM 5 0402	R718	0613952G67	CER CHIP RES 0.0 +/-0.050 OHM	R765	NOTPLACED		R795	0613952R17	CER CHIP RES 47K OHM 5% 0402
			R722	0613952R08	CER CHIP RES 20K OHM 5 0402	R767	0613952R66	CER CHIP RES 0.0 +/-0.050 OHM	R796	0613952R66	CER CHIP RES 0.0 +/-0.050 OHM
			R725	0613952R66	CER CHIP RES 0.0 +/-0.050 OHM				R797	0613952Q41	CER CHIP RES 47.0 OHM 5 0402
			R726	0613952R66	CER CHIP RES 0.0 +/-0.050 OHM				R798	0613952Q61	CER CHIP RES 330 OHM 5 0402

ITEM	MOTOROLA PART NUMBER	DESCRIPTION
R799	0613952R01	CER CHIP RES 10K OHM 5% 0402
R801	NOTPLACED	
R802	0613952Q49	CER CHIP RES 100 OHM 5 0402
R803	0613952Q49	CER CHIP RES 100 OHM 5 0402
R804	0613952Q66	CER CHIP RES 510 OHM 5 0402
R805	0613952R01	CER CHIP RES 10K OHM 5% 0402
R806	0613952Q66	CER CHIP RES 510 OHM 5 0402
R807	0613952R01	CER CHIP RES 10K OHM 5% 0402
R808	0613952R66	CER CHIP RES 0.0 +/-0.050 OHM
R809	0613952R17	CER CHIP RES 47K OHM 5% 0402
R810	0613952R01	CER CHIP RES 10K OHM 5% 0402
R811	0613952Q66	CER CHIP RES 510 OHM 5 0402
R812	0613952R25	CER CHIP RES 100K OHM 5% 0402
R813	0613952R66	CER CHIP RES 0.0 +/-0.050 OHM
R814	NOTPLACED	
R815	0613952R66	CER CHIP RES 0.0 +/-0.050 OHM
R816	0613952R17	CER CHIP RES 47K OHM 5% 0402
R820	0613952R01	CER CHIP RES 10K OHM 5% 0402
R829	NOTPLACED	
R837	0613952Q37	CER CHIP RES 33.0 OHM 5 0402
R838	0613952Q37	CER CHIP RES 33.0 OHM 5 0402
R839	0613952R01	CER CHIP RES 10K OHM 5% 0402
R840	0613952Q66	CER CHIP RES 510 OHM 5 0402
R841	0613952R01	CER CHIP RES 10K OHM 5% 0402
R842	0613952R01	CER CHIP RES 10K OHM 5% 0402

ITEM	MOTOROLA PART NUMBER	DESCRIPTION
R843	0613952R41	CER CHIP RES 470K OHM 5% 0402
R844	0613952Q61	CER CHIP RES 330 OHM 5 0402
SH1	2686707Z02	SHIELD, SM SLDRD,CRS,PLTD
S500	4085131E03	SWITCH FREQ DUAL FUNCTION
S501	1880619Z06	POTENTIOMETER, VOLUME
S502	4016618H01	SWITCH SURFACE MOUNT
S503	4070354A01	LIGHT TOUCH SWITCH-SMD
S504	4070354A01	LIGHT TOUCH SWITCH-SMD
S505	4070354A01	LIGHT TOUCH SWITCH-SMD
S506	4070354A01	LIGHT TOUCH SWITCH-SMD
SH51	2686700Z02	SHIELD, SM SLDRD,CRS,PLTD
SH52	2686699Z02	SHIELD, SM SLDRD,CRS,PLTD
SH101	2686702Z02	SHIELD, SM SLDRD,CRS,PLTD
SH102	2686701Z02	SHIELD, SM SLDRD,CRS,PLTD
SH103	2686708Z02	SHIELD, SM SLDRD,CRS,PLTD
SH201	2686705Z02	SHIELD, SM SLDRD,CRS,PLTD
SH251	2616554H01	SHLD VCO TOP
SH252	2616559H01	SHLD PCIC
SH401	2686706Z02	SHIELD, SM SLDRD,CRS,PLTD
SH402	2686698Z02	SHIELD, SM SLDRD,CRS,PLTD
SH500	NOTPLACED	
T51	2515121H01	BALUN, TRANSFORMER W18 COMP
T53	2516320H01	XFMR SMALL SIGNAL SURFACE MT
U1	5164015H81	IC,MXR,DBL BAL GILBERT,CELL,SM
U2	5185941F45	ATTEN,VAR,14.4DBMIN,15.6DBM AX,0-2000 MHZFREQ,
U3	5116349H01	DUAL INVERTER IC
U101	5115678H01	VHF/UHF/800/900 MHZ LD MOS DRIVER IC
U102	5185765B26	IC PWR CTRL IN MOS20

Notes

ITEM	MOTOROLA PART NUMBER	DESCRIPTION
U103	5115022H01	IC TEMPERATURE SENSOR
U201	5116411H01	IC,OP AMP,
U202	5116245H01	CC LVFRACN
U401	5185963A85	IC-ABACUS III-LP
U500	5188493T01	IC,VREG/SWG,LP2989,SM,IC MINI SO-8 HI PRCN RE
U501	5185941F35	IC, VREG, NOPB
U502	5185941F35	IC, VREG, NOPB
U601	5185941F22	IC,OPAMP,SGL,OPA237,SOT23, NOPB
U602	5185941F22	IC,OPAMP,SGL,OPA237,SOT23, NOPB
U701	5185143E77	IC, MAKO ASIC, CMOS PWR MGMT
U702	5185941F22	IC,OPAMP,SGL,OPA237,SOT23, NOPB
U705	5114000B39	IC,BFR,1PER PKG,SM,SOT-353,PB-FREE
U712	5188691V01	IC,MUX/ DEMUX,NC7SB3157P6X,SM,SC70-6,1PER PKG
U713	5115453H01	RAIL TO RAIL OUTPUT, 8 PIN BGA
U714	5115453H01	RAIL TO RAIL OUTPUT, 8 PIN BGA
U800	5185941F04	IC, PATRIOT BRAVO, 1.2.2,256BGA, PB-FREE
U801	5114000B39	IC,BFR,1PER PKG,SM,SOT-353,PB-FREE
U802	5114000B39	IC,BFR,1PER PKG,SM,SOT-353,PB-FREE
U803	5185956E69	IC,DRAM,64MB,60NS,IC 1.8V 64
U804	5185941F03	IC,SRAM,8M,512KX16,70NS,SM, FBGA48,1.95V
U811	5185941F40	IC, 12 BIT DAC
VR500	4809788E21	DIODE, ZENER, SOD-323, SMD, W18 COMPLIANT

ITEM	MOTOROLA PART NUMBER	DESCRIPTION
VR501	4813977M19	DIODE,ZEN,MBZ5240,SM,SOT-23,10V,10MA,.225W,ZE
VR502	4809788E21	DIODE, ZENER, SOD-323, SMD, W18 COMPLIANT
VR503	4809788E21	DIODE, ZENER, SOD-323, SMD, W18 COMPLIANT
VR504	4809788E21	DIODE, ZENER, SOD-323, SMD, W18 COMPLIANT
VR505	4809788E21	DIODE, ZENER, SOD-323, SMD, W18 COMPLIANT
VR506	4809788E21	DIODE, ZENER, SOD-323, SMD, W18 COMPLIANT
VR507	4809788E21	DIODE, ZENER, SOD-323, SMD, W18 COMPLIANT
VR508	4813977A43	PB-FREE, NOTCOMPLETELYENRICHED
VR509	4813977A43	PB-FREE, NOTCOMPLETELYENRICHED
VR510	4813977A43	PB-FREE, NOTCOMPLETELYENRICHED
VR511	4813977A43	PB-FREE, NOTCOMPLETELYENRICHED
VR512	4813977A43	PB-FREE, NOTCOMPLETELYENRICHED
VR513	4813977A43	PB-FREE, NOTCOMPLETELYENRICHED
VR650	4813979P12	DIODE ARRAY,TRANSIENT PROTECTION,SM,SOT-457,1
VR651	4813977A43	PB-FREE, NOTCOMPLETELYENRICHED
VR652	4813977A43	PB-FREE, NOTCOMPLETELYENRICHED
VR657	4809788E21	DIODE, ZENER, SOD-323, SMD, W18 COMPLIANT
VR658	4813977C23	DIODE,ZEN,MMSZ5243,SM,SOD-123,13V,10MA,.5W,ZE
VR659	4813979P10	DIODE ARRAY,TRANSIENT PROTECTION,SM,SOT-457,5
VR662	4813979P10	DIODE ARRAY,TRANSIENT PROTECTION,SM,SOT-457,5

ITEM	MOTOROLA PART NUMBER	DESCRIPTION
VR663	4813977M18	DIODE,ZEN,MBZ5239,SM,SOT-23,9.1V,10MA,.225W,Z
VR678	4866544A01	DIODE ARRAY,ZEN,SR05.TCT,SM,5V,5,LOW CAPA
VR701	4813977M11	DIODE,ZEN,MBZ5232,SM,SOT-23,5.6V,10MA,.225W,Z
Y200	4802245J68	OSC, REF 16.8 MHZ 1.5 PPM
Y701	4809995L05	XTAL QUARTZ 32.768KHZ CC4V-T1
Y702	4864005H01	RESONATOR, CRYSTAL 24.576 MHZ
	6003710K08	BATT COIN 3.3V LIION
	1085674C03	PASTE/NC-SMQ230
	PMLN4624A	PEELABLE LABEL KIT
	4285633D01	RETAINING CLIP

Notes:

- For optimum performance, order replacement diodes, transistors, and circuit modules by Motorola part number only.
- When ordering crystals, specify carrier frequency, crystal frequency, crystal type number, and Motorola part number.
- Part value notations:
 $p=10^{-12}$
 $n=10^{-9}$
 $\mu=10^{-6}$
 $m=10^{-3}$
 $k=10^3$
 $M=10^6$
- ITEM refers to the component reference designator. SIDE refers to the location of the component on the board; S1=Side 1, S2=Side 2.
- The PMLE2537A RF Board uses a 6-layer printed circuit board.

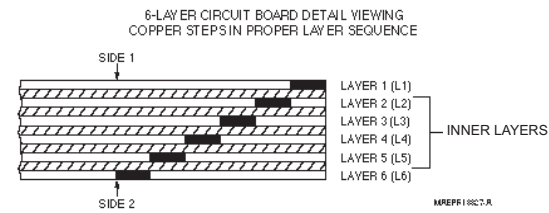

Notes

Chapter 9.3 UHF2 Schematics, Board Overlays, and Parts Lists

9.3.1 Introduction

This chapter contains the schematics, board layouts, and parts lists for the XTS 2500/2500I/2250/1500 radios. Use them in conjunction with the theory of operation and the troubleshooting procedures, charts, and waveforms to isolate a problem to the component level.

Table 9.3-1. UHF2 Schematics, Board Overlays and Parts Lists

Schematic/Board Layout	Page No.
PMLE4427A/ PMLE4427B (8416852H01_A)	9.3-2
PMLE4427A Controls	9.3-3
PMLE4427B Controls	9.3-4
PMLE4427A/ PMLE4427B Controller Interface Schematic	9.3-5
PMLE4427A/ PMLE4427B Patriot Bravo Revision Schematic	9.3-6
PMLE4427A/ PMLE4427B Digital to Analog Schematic	9.3-7
PMLE4427A/ PMLE4427B Frequency Generation Unit (FGU) Schematic	9.3-8
PMLE4427A/ PMLE4427B Interface and Accessories Schematic	9.3-9
PMLE4427A/ PMLE4427B LNA Schematic	9.3-10
PMLE4427A/ PMLE4427B MAKO Schematic - Sheet 1 of 2	9.3-11
PMLE4427A/ PMLE4427B MAKO Schematic - Sheet 2 of 2	9.3-12
PMLE4427A/ PMLE4427B Memory Schematic	9.3-13
PMLE4427A/ PMLE4427B Mixer Schematic	9.3-14
PMLE4427A/ PMLE4427B Patriot Schematic	9.3-15
PMLE4427A/ PMLE4427B Regulators Schematic	9.3-16
PMLE4427A/ PMLE4427B RF Schematic	9.3-17
PMLE4427A/ PMLE4427B RX Schematic	9.3-18
PMLE4427A/ PMLE4427B RX (back-end) Schematic	9.3-19
PMLE4427A/ PMLE4427B RX (front-end) Schematic	9.3-20
PMLE4427A/ PMLE4427B Side Connector Schematic	9.3-21
PMLE4427A Synthesizer Schematic	9.3-22
PMLE4427B Synthesizer Schematic	9.3-23
PMLE4427A/ PMLE4427B TX Schematic	9.3-24
PMLE4427A/ PMLE4427B VCO Schematic	9.3-25
8416852H01_A Top Overlay	9.3-26
8416852H01_A Bottom Overlay	9.3-27
PMLE4427A/ PMLE4427B Main Circuit Board Electrical Parts List	9.3-28

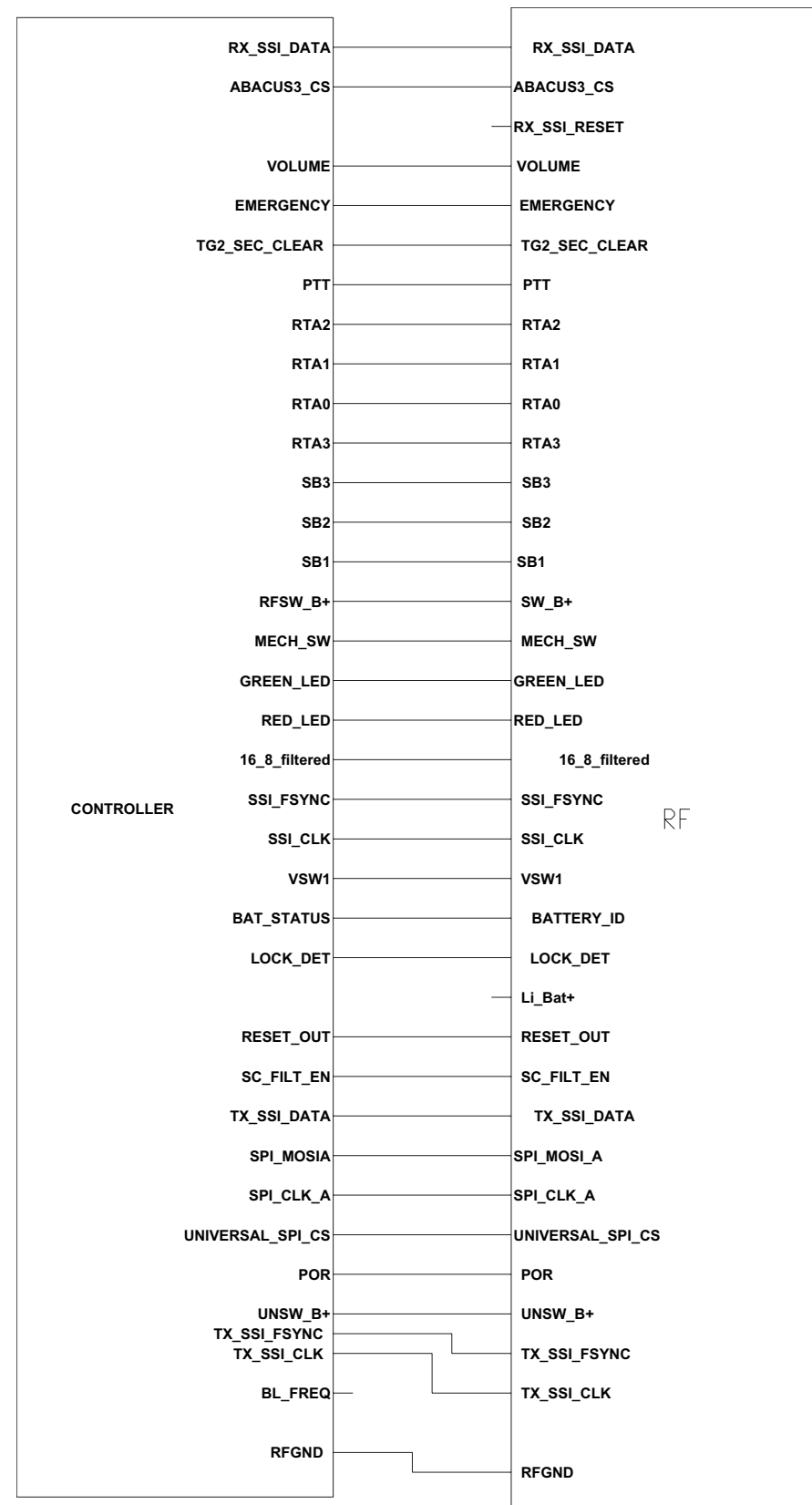

Figure 9.3-1. PMLE4427A/ PMLE4427B (8416852H01_A)

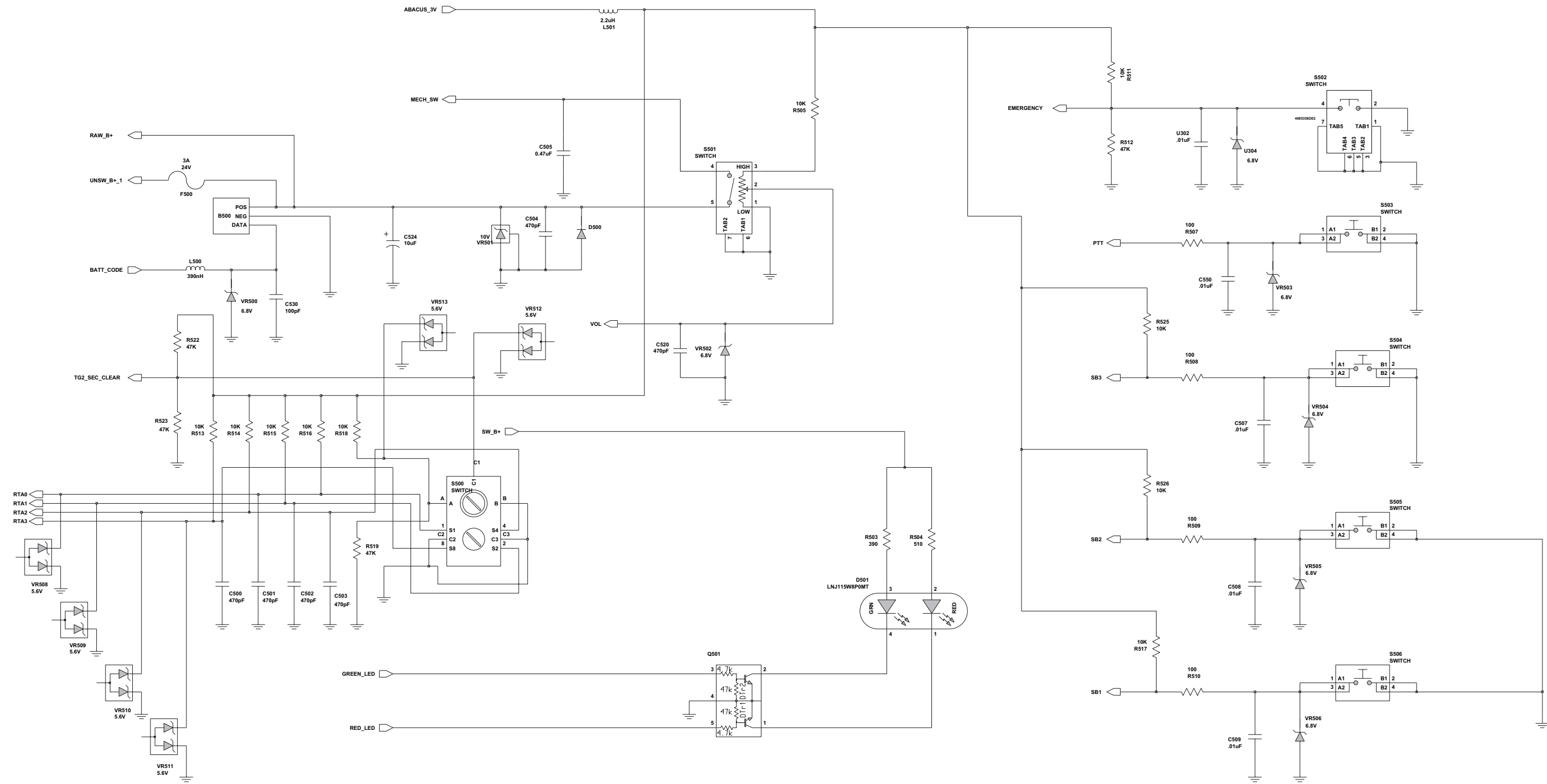

Figure 9.3-2. PMLE4427A Controls

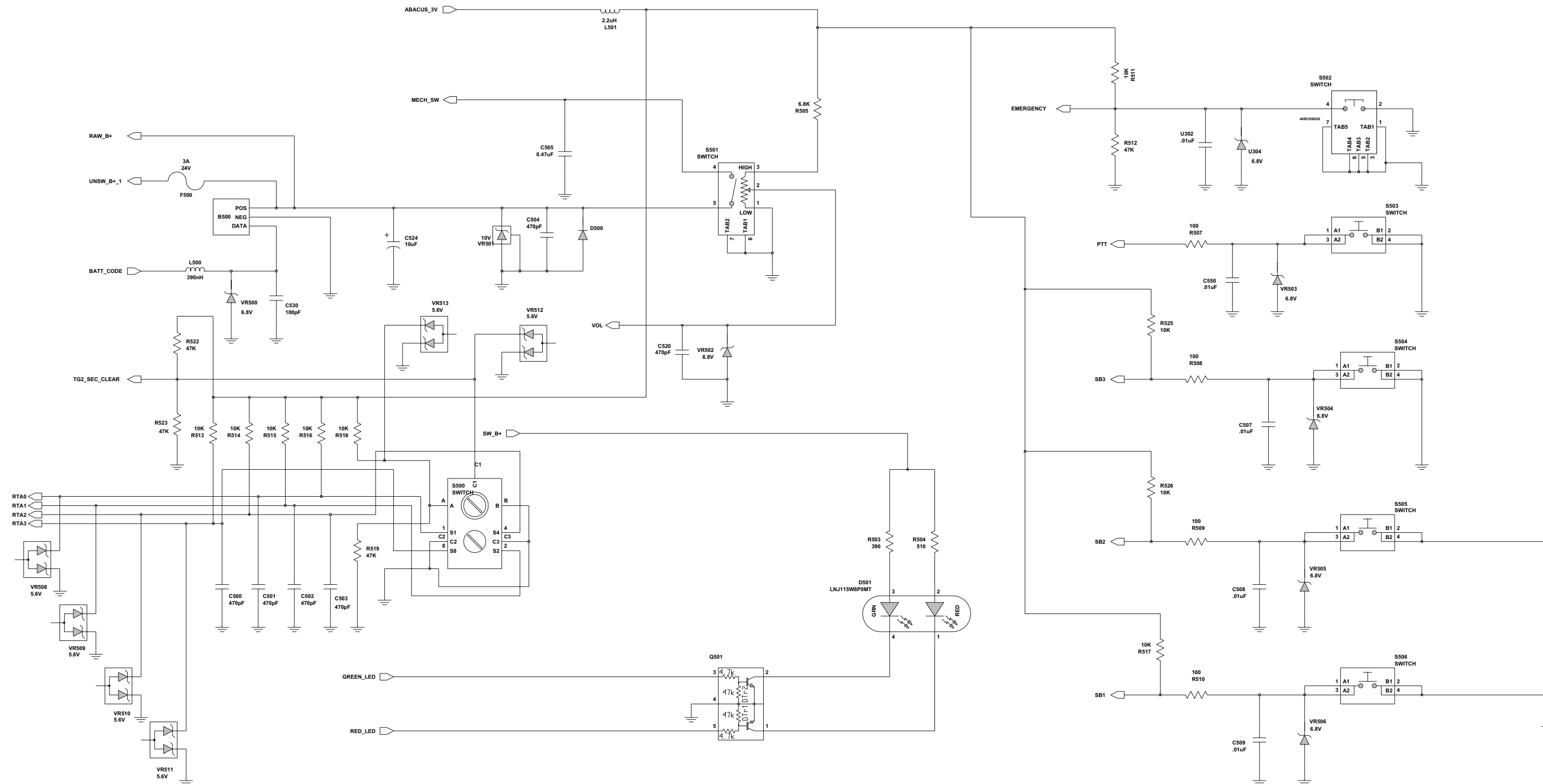

Figure 9.3-3. PMLE4427B Controls

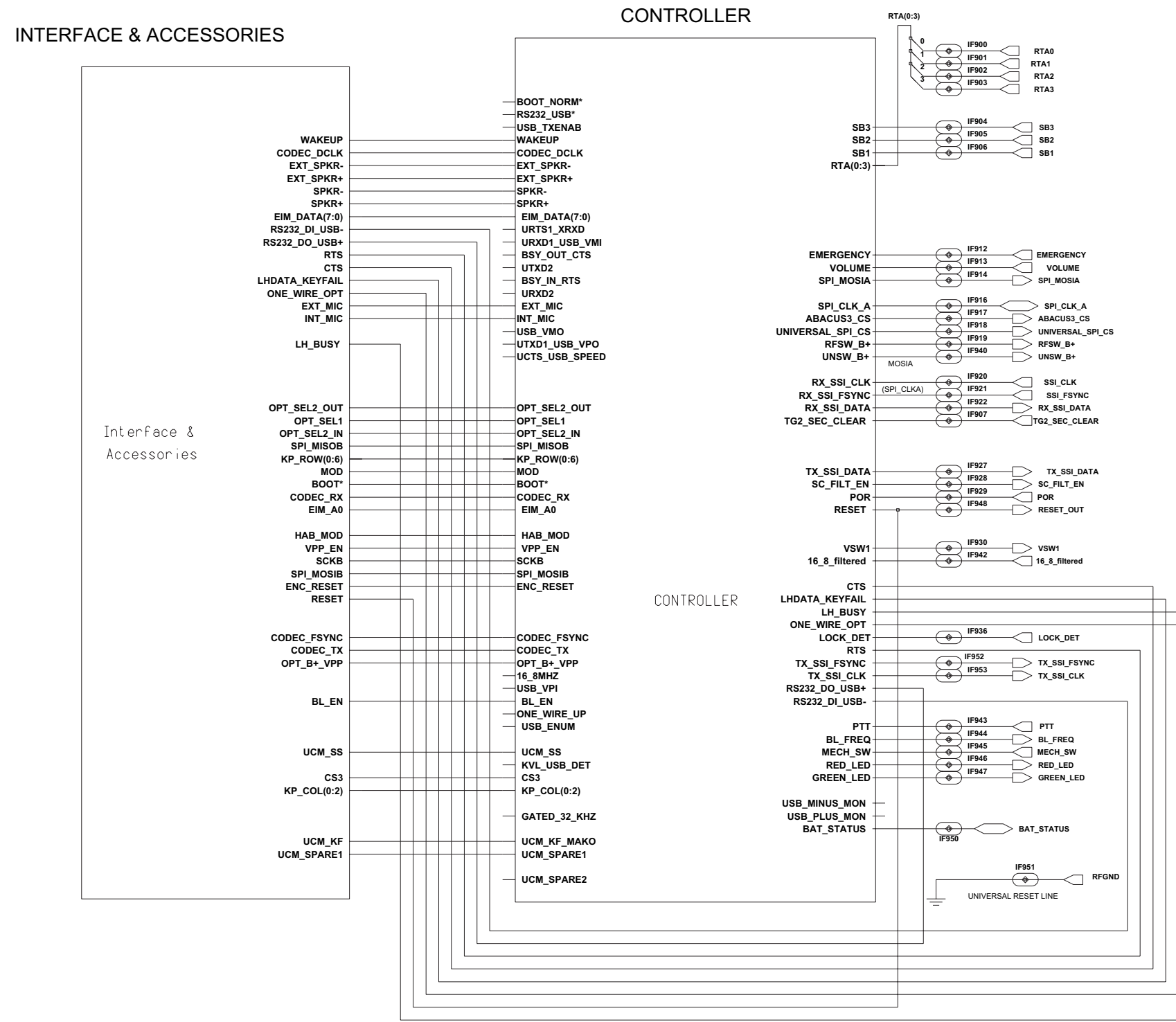

Figure 9.3-4. PMLE4427A/ PMLE4427B Controller Interface Schematic

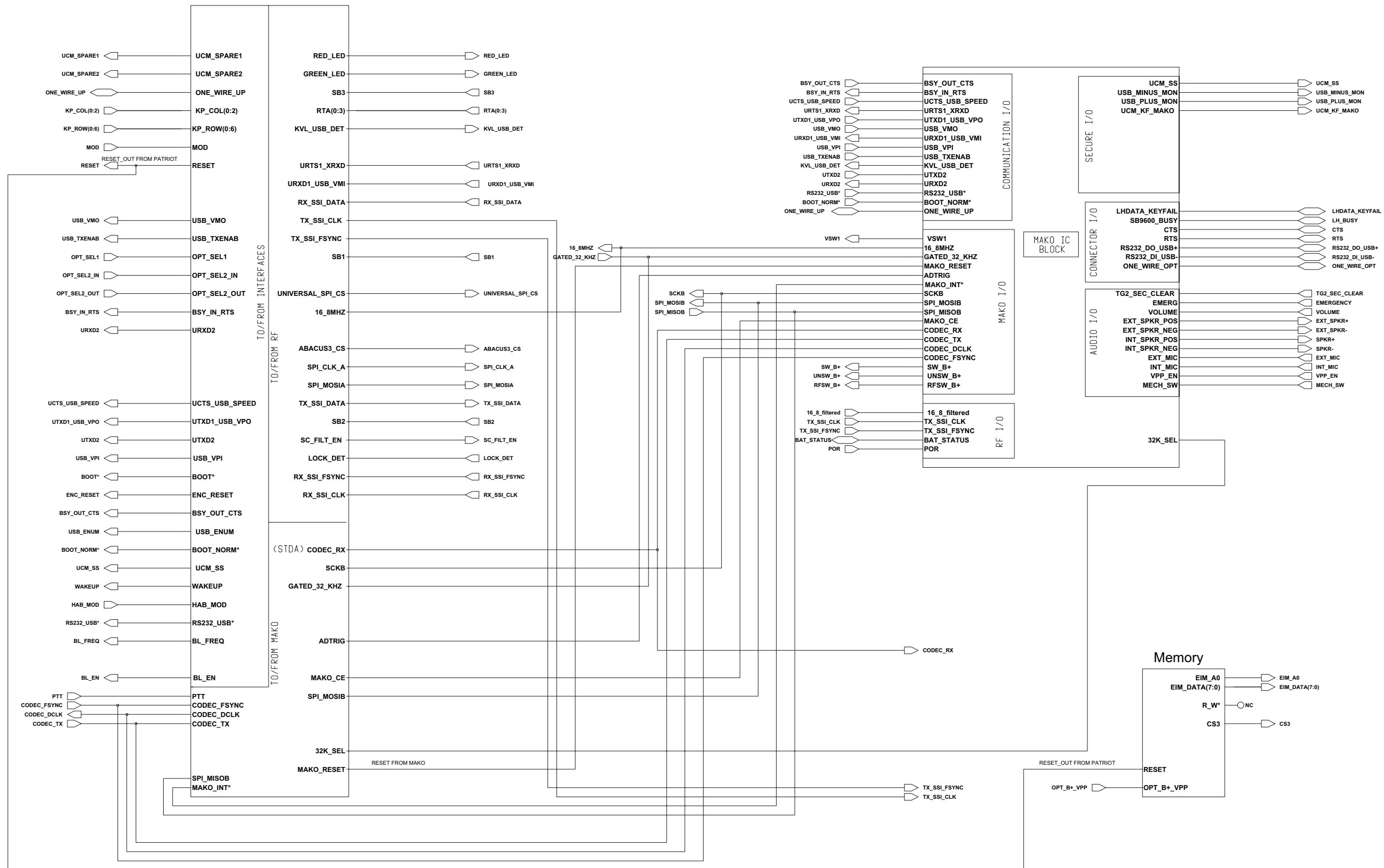

Figure 9.3-5. PMLE4427A/ PMLE4427B Patriot Bravo Revision Schematic

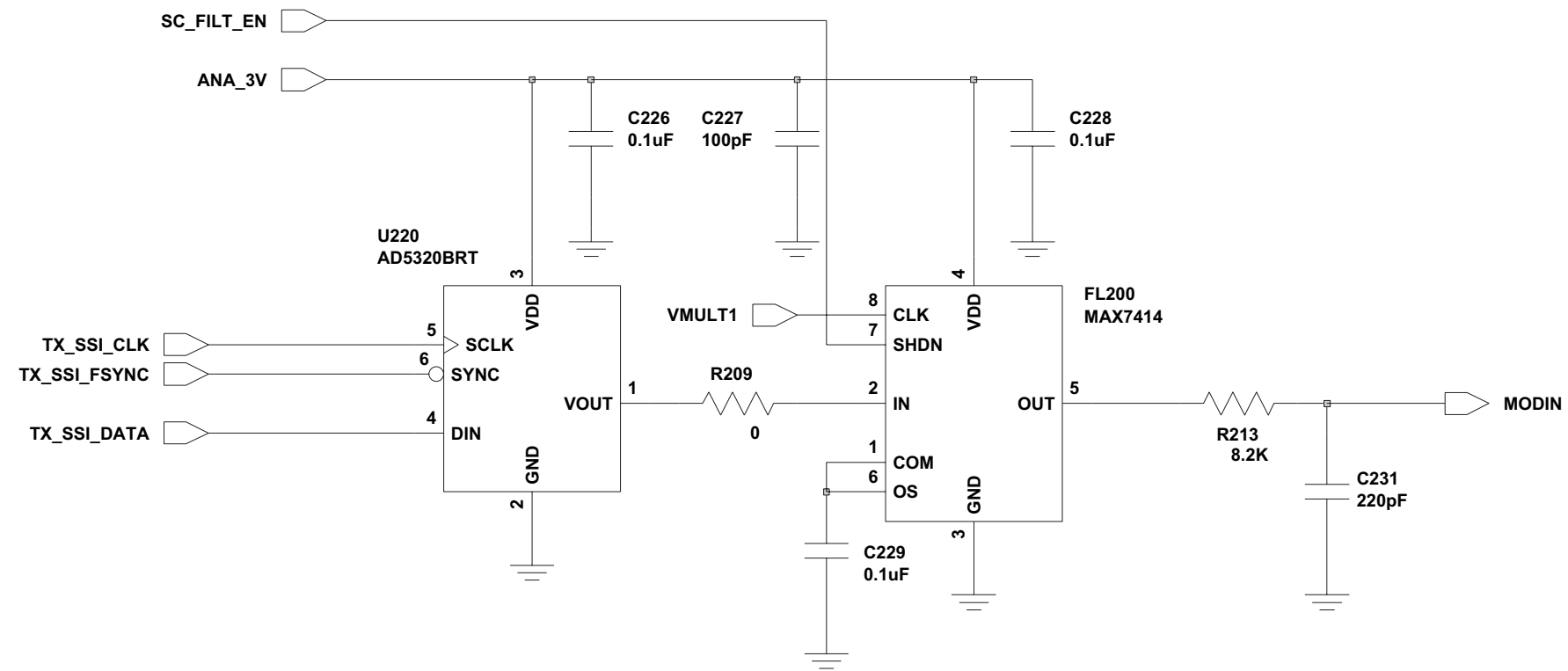

Figure 9.3-6. PMLE4427A/ PMLE4427B Digital to Analog Schematic

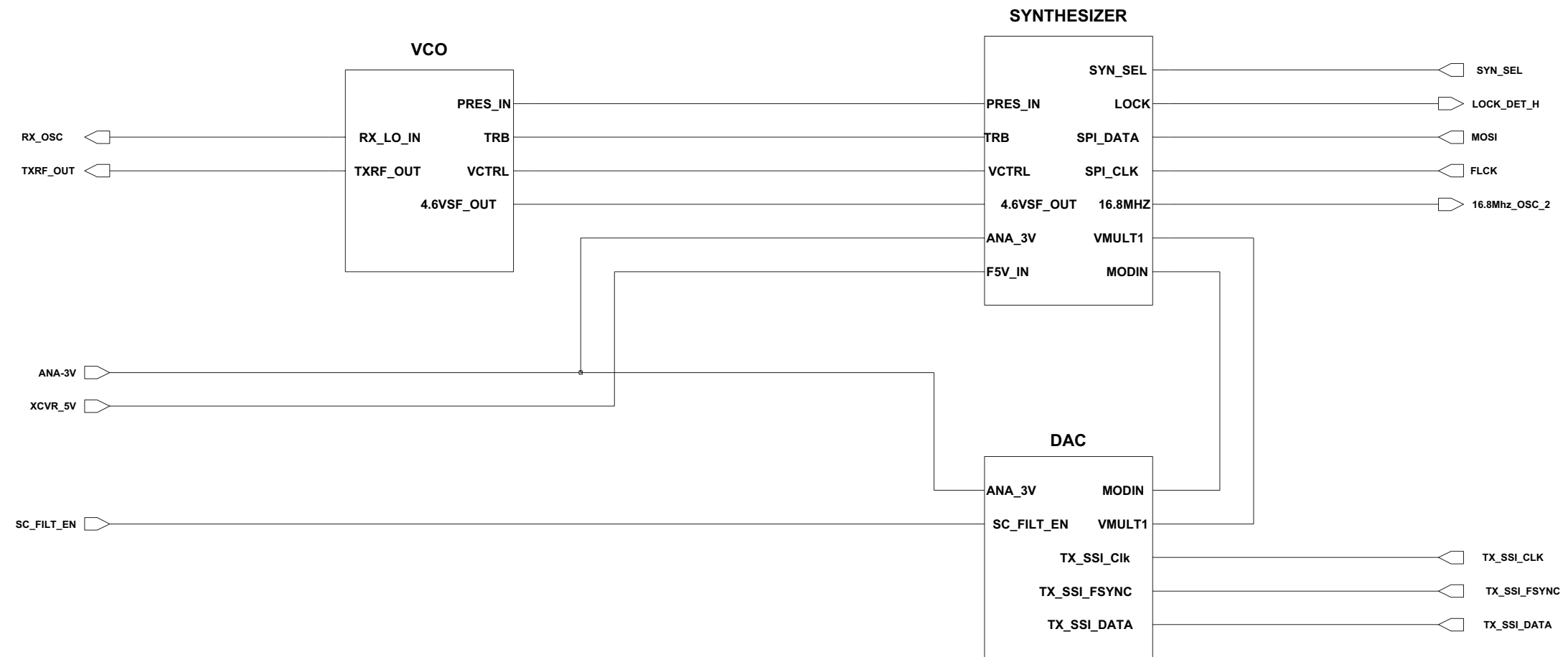

Figure 9.3-7. PMLE4427A/ PMLE4427B Frequency Generation Unit (FGU) Schematic

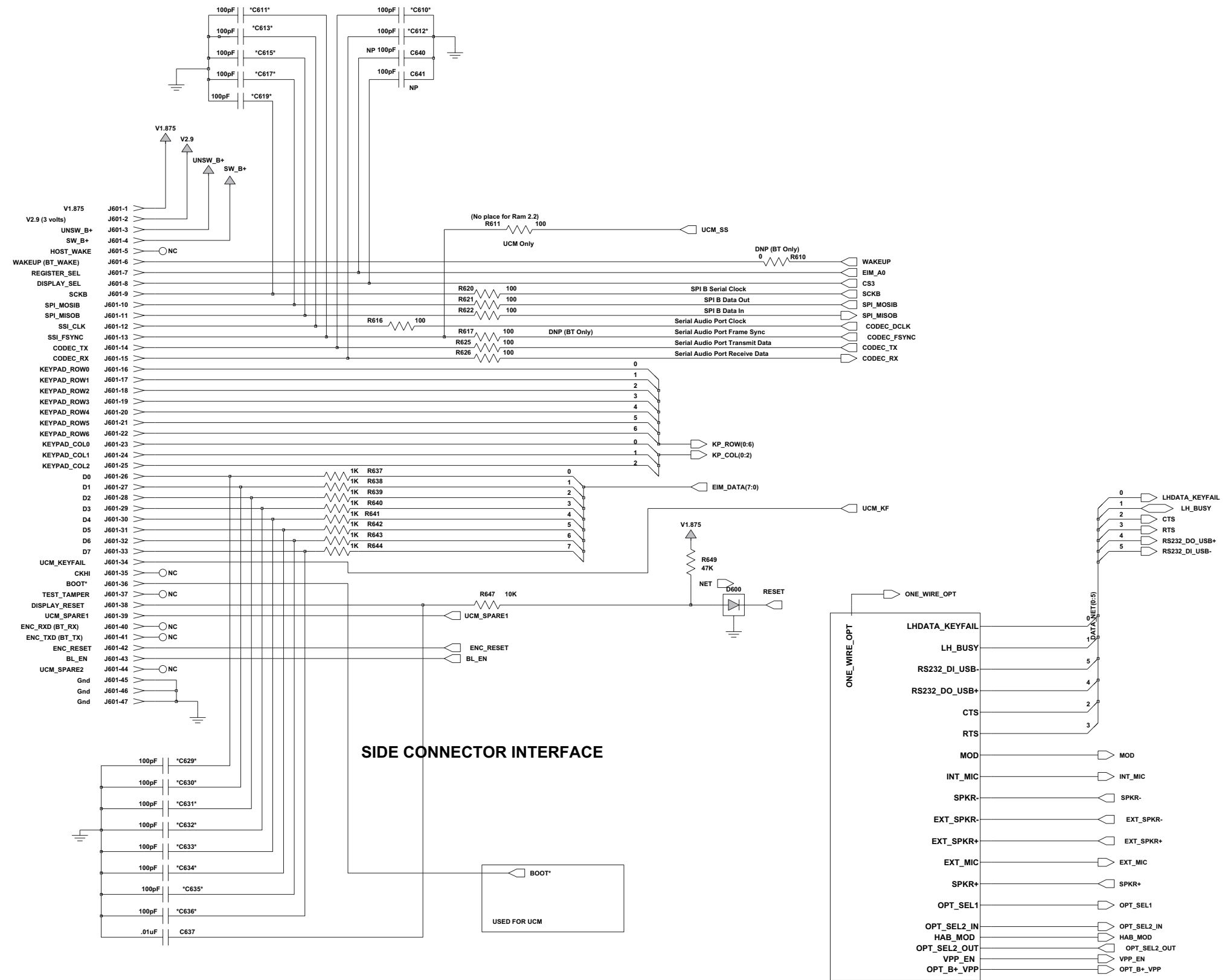

Figure 9.3-8. PMLE4427A/ PMLE4427B Interface and Accessories Schematic

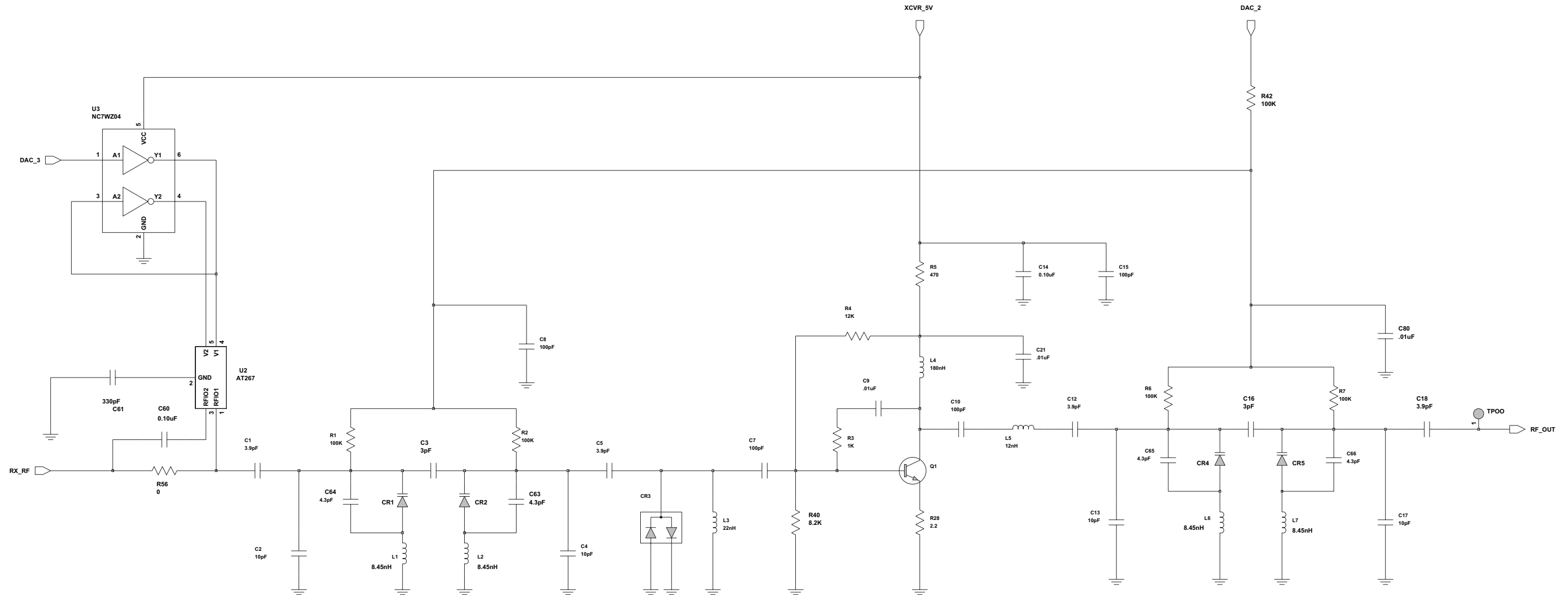

Figure 9.3-9. PMLE4427A/PMLE4427B LNA Schematic

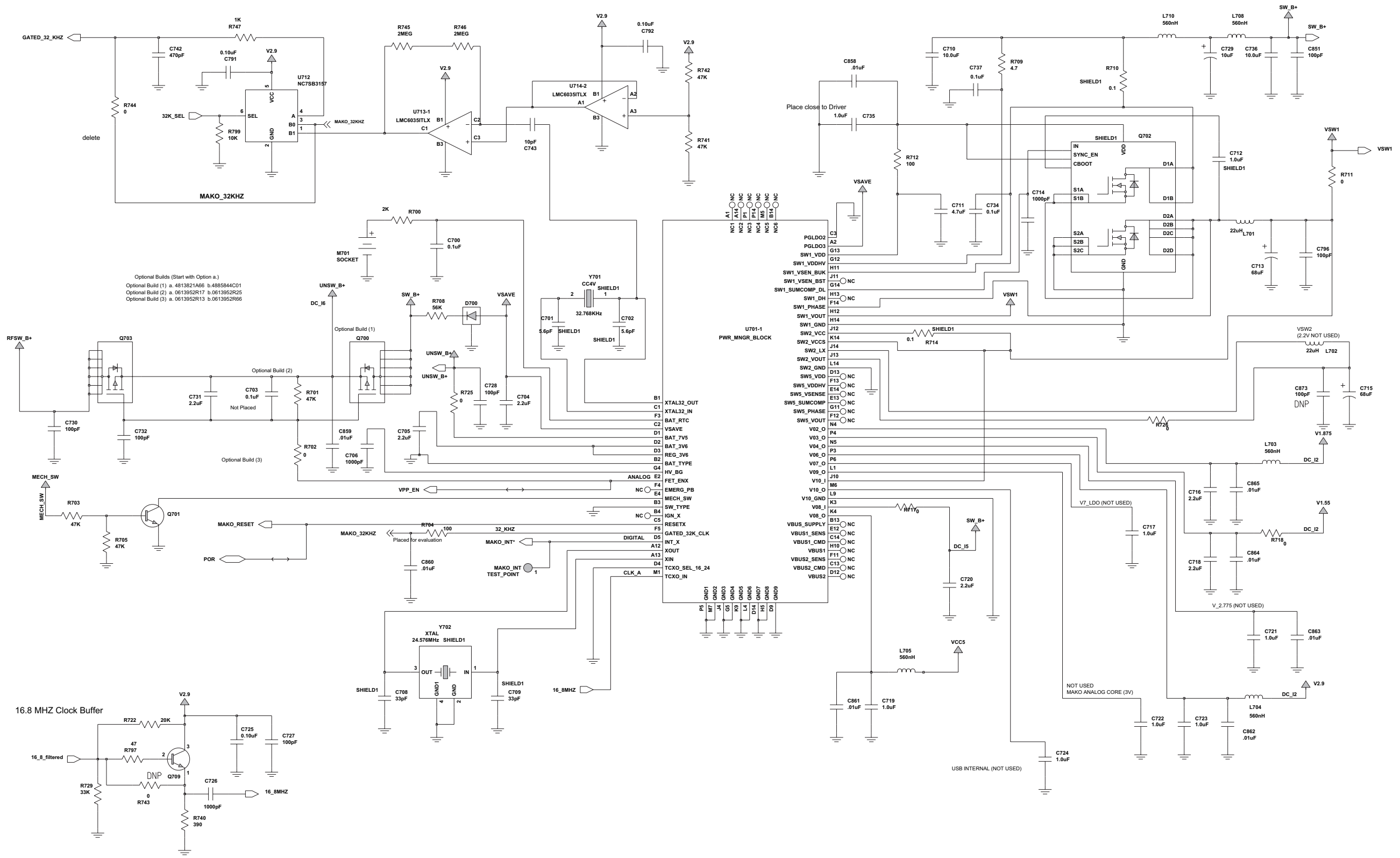

Figure 9.3-10. PMLE4427A/ PMLE4427B MAKO Schematic - Sheet 1 of 2

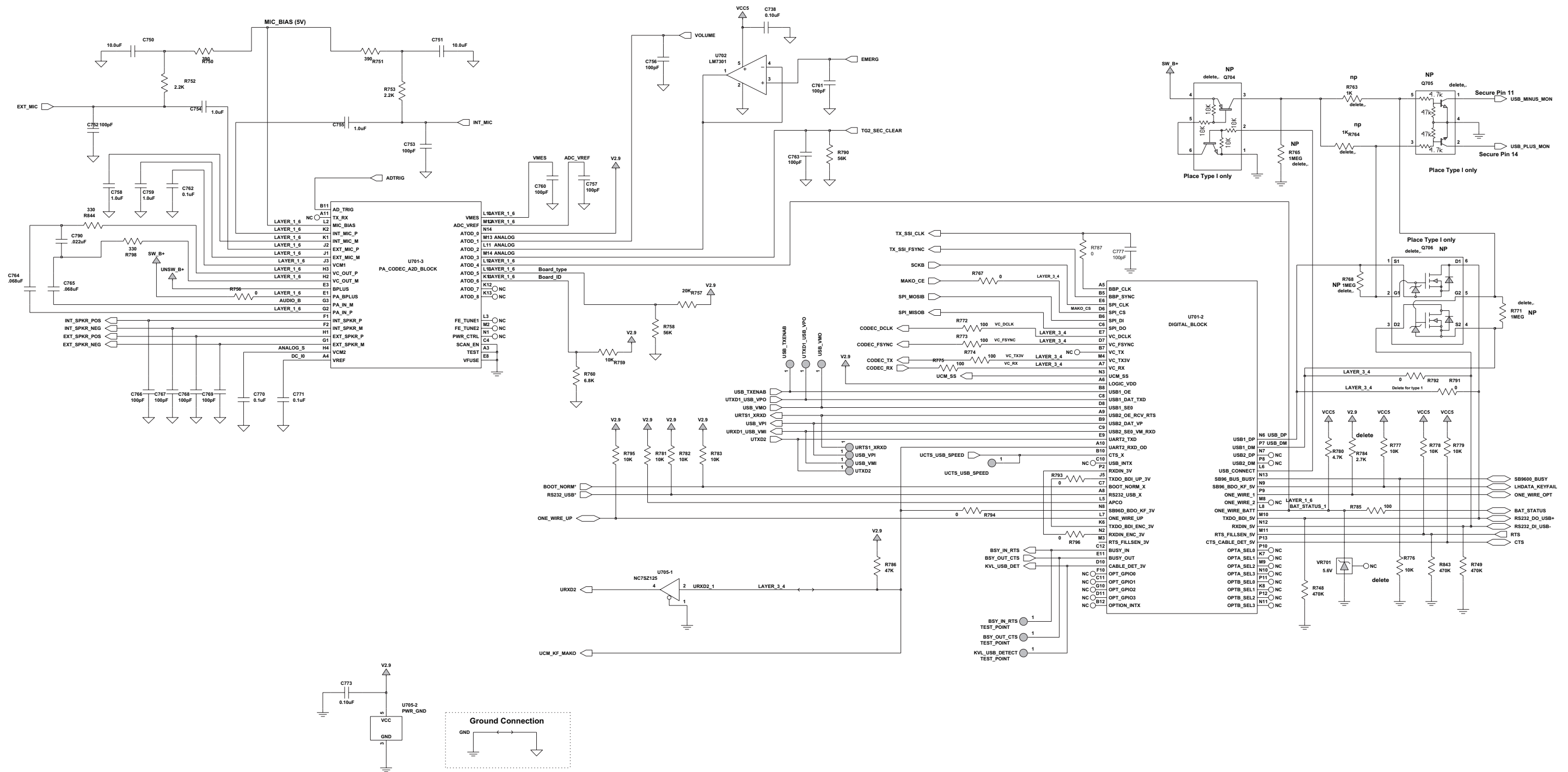

Figure 9.3-11. PMLE4427A/ PMLE4427B MAKO Schematic - Sheet 2 of 2

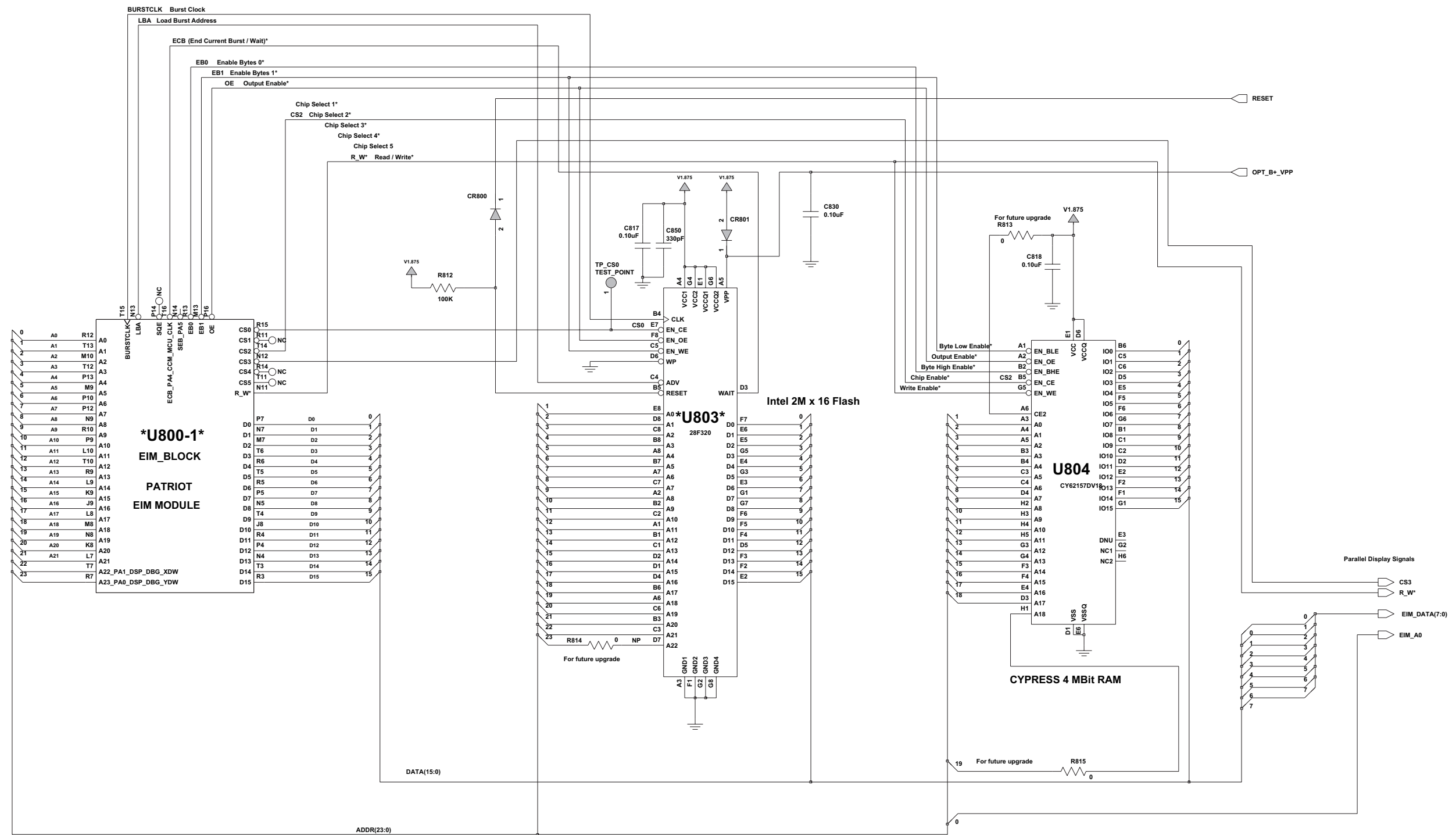

Figure 9.3-12. PMLE4427A/ PMLE4427B Memory Schematic

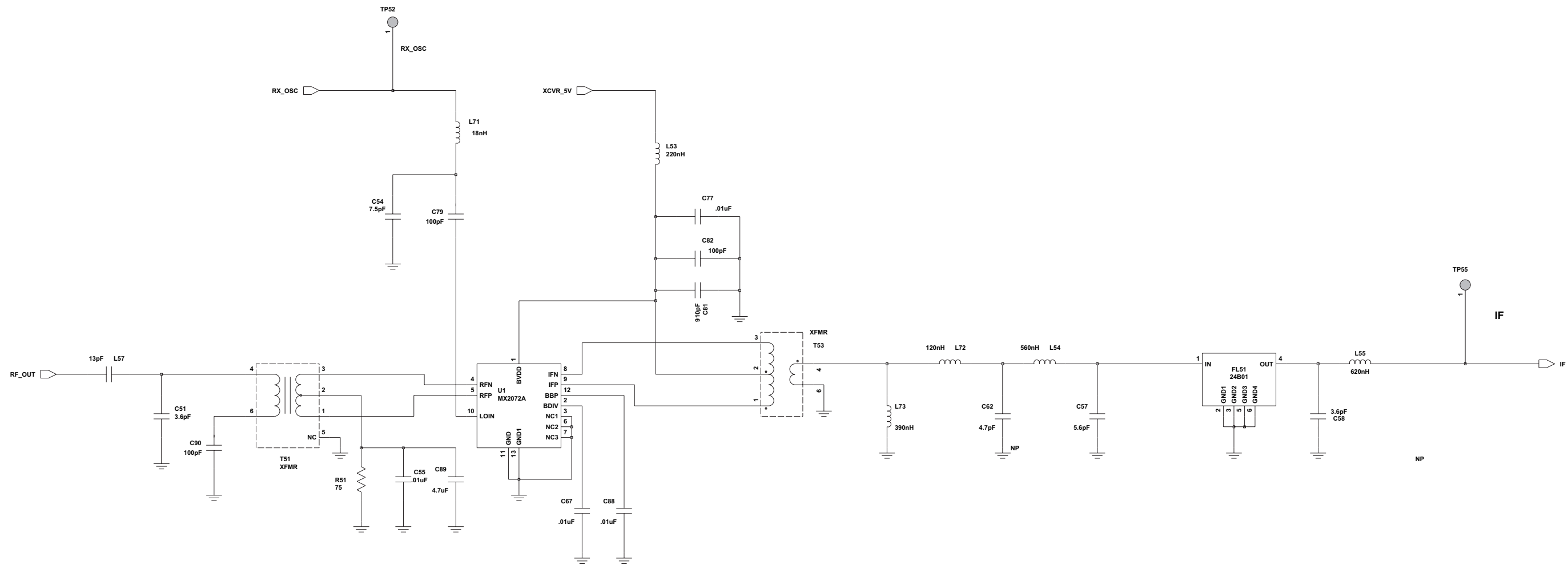

Figure 9.3-13. PMLE4427A/ PMLE4427B Mixer Schematic

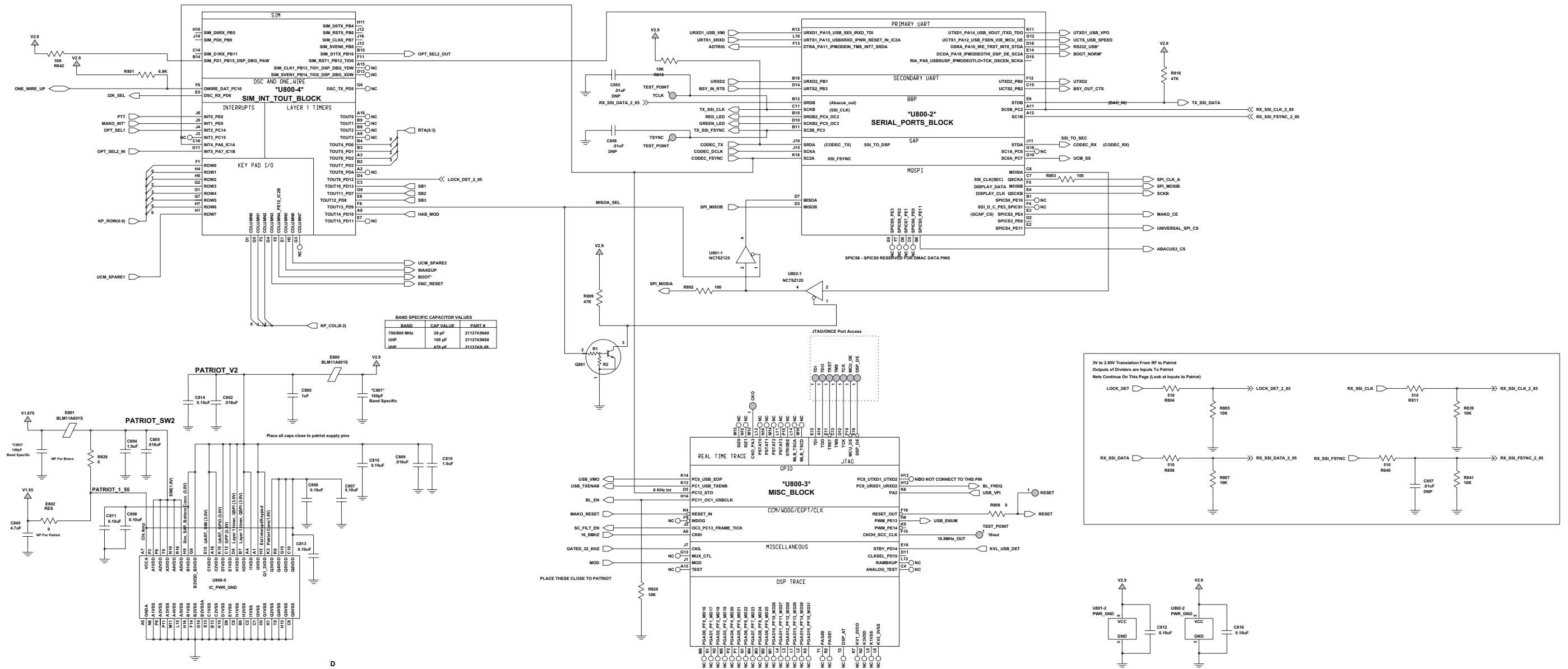

Figure 9.3-14. PMLE4427A/ PMLE4427B Patriot Schematic

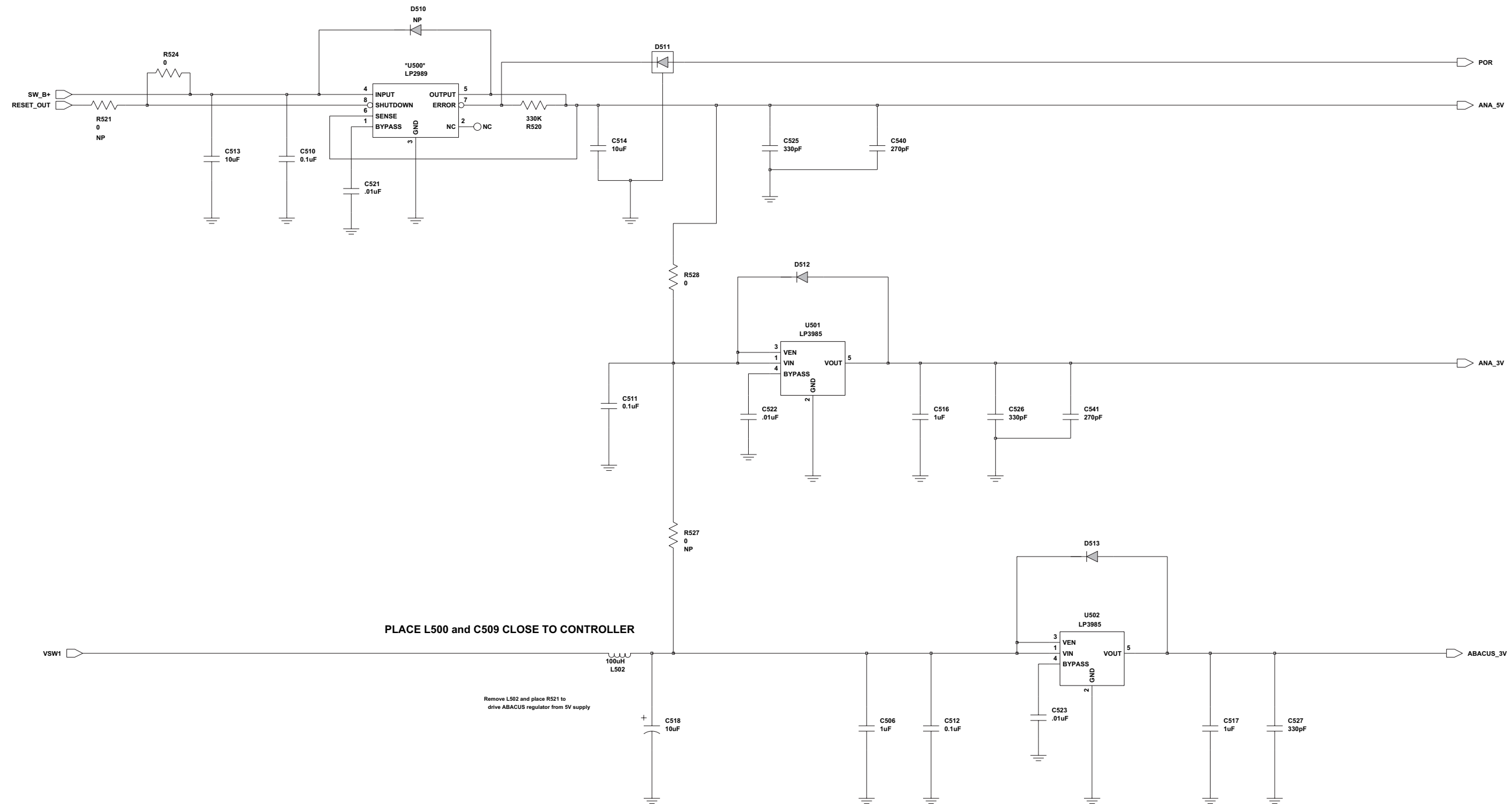

Figure 9.3-15. PMLE4427A/ PMLE4427B Regulators Schematic

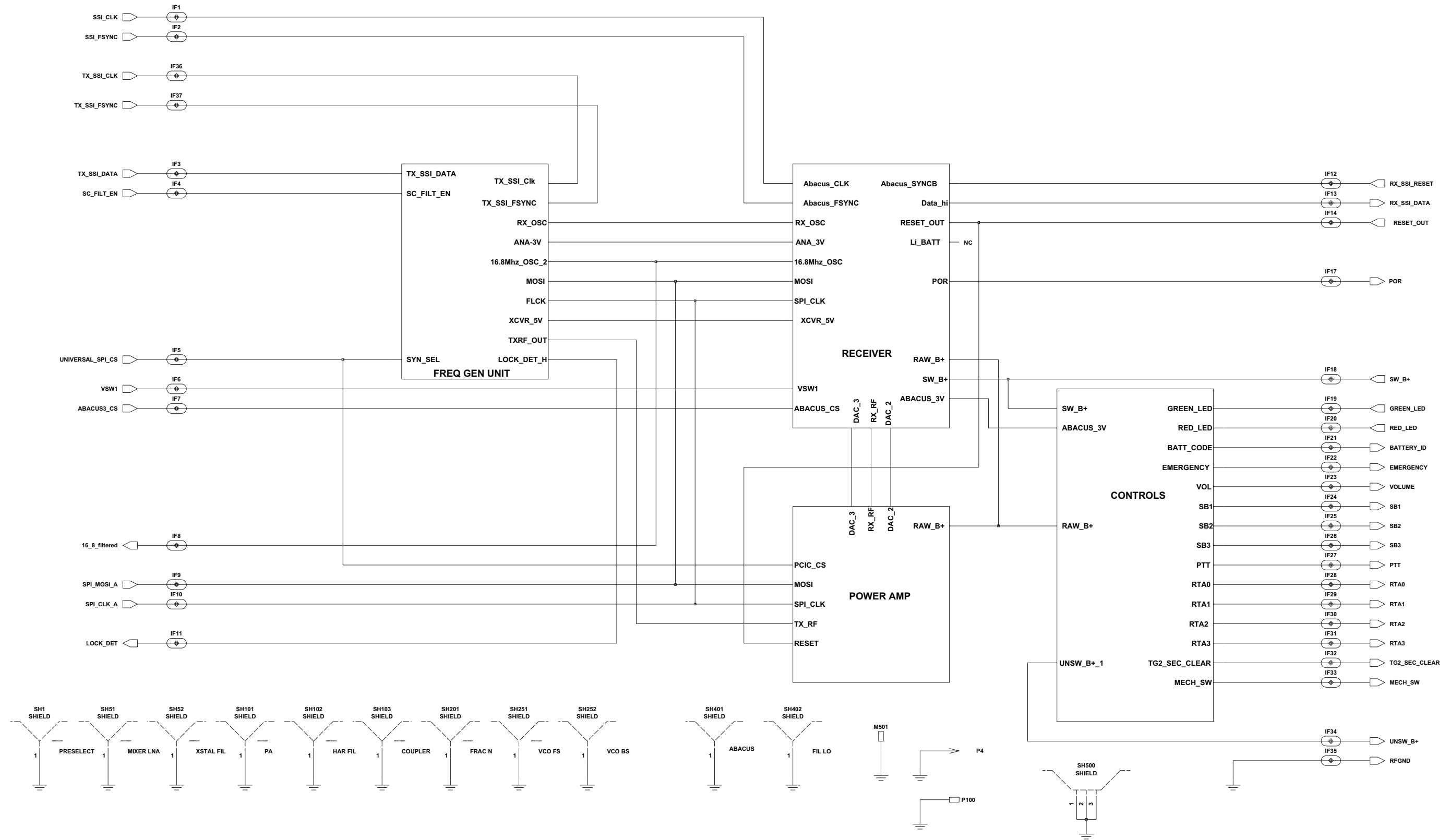

Figure 9.3-16. PMLE4427A/ PMLE4427B RF Schematic

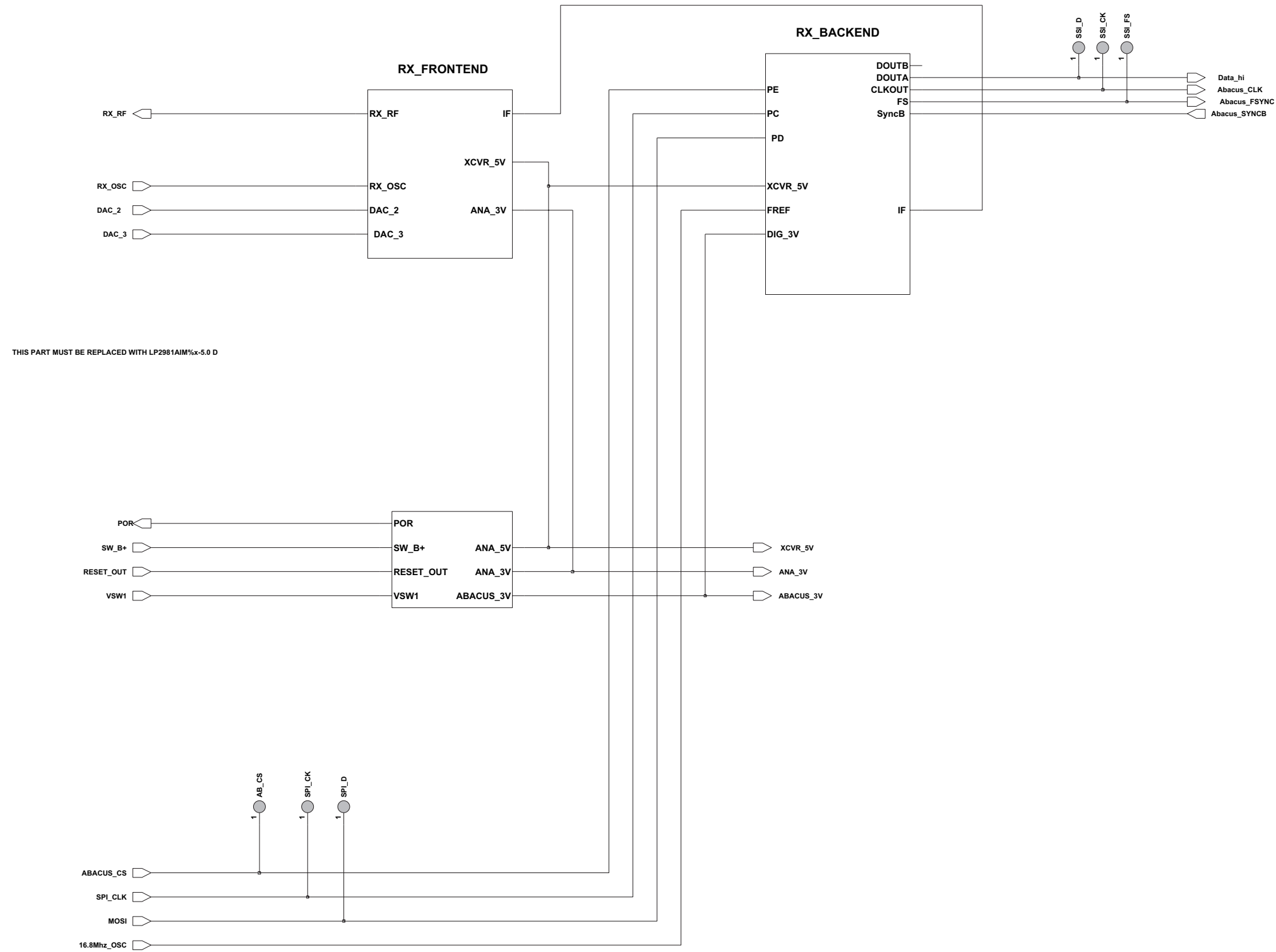

Figure 9.3-17. PMLE4427A/ PMLE4427B RX Schematic

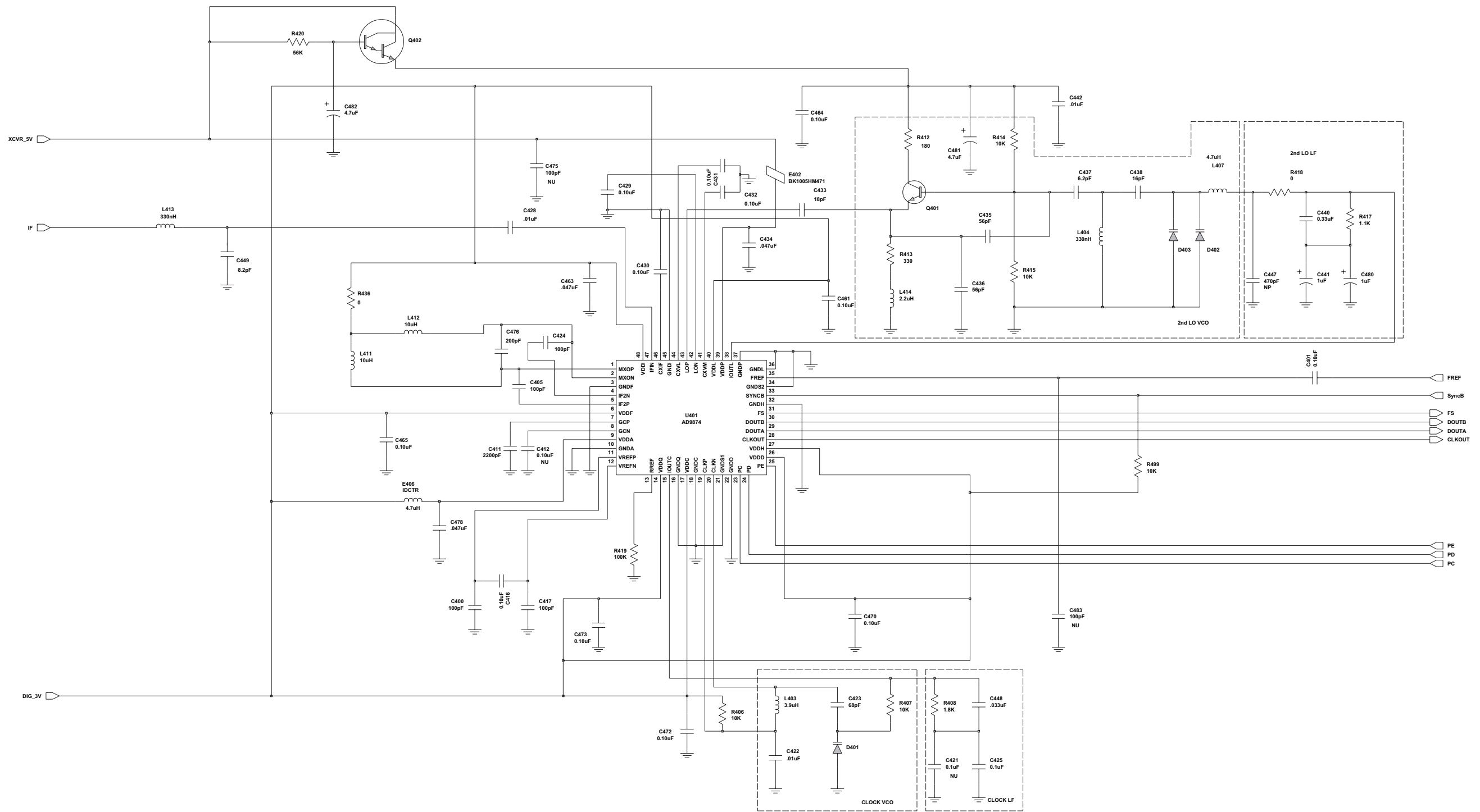

Figure 9.3-18. PMLE4427A/ PMLE4427B RX (back-end) Schematic

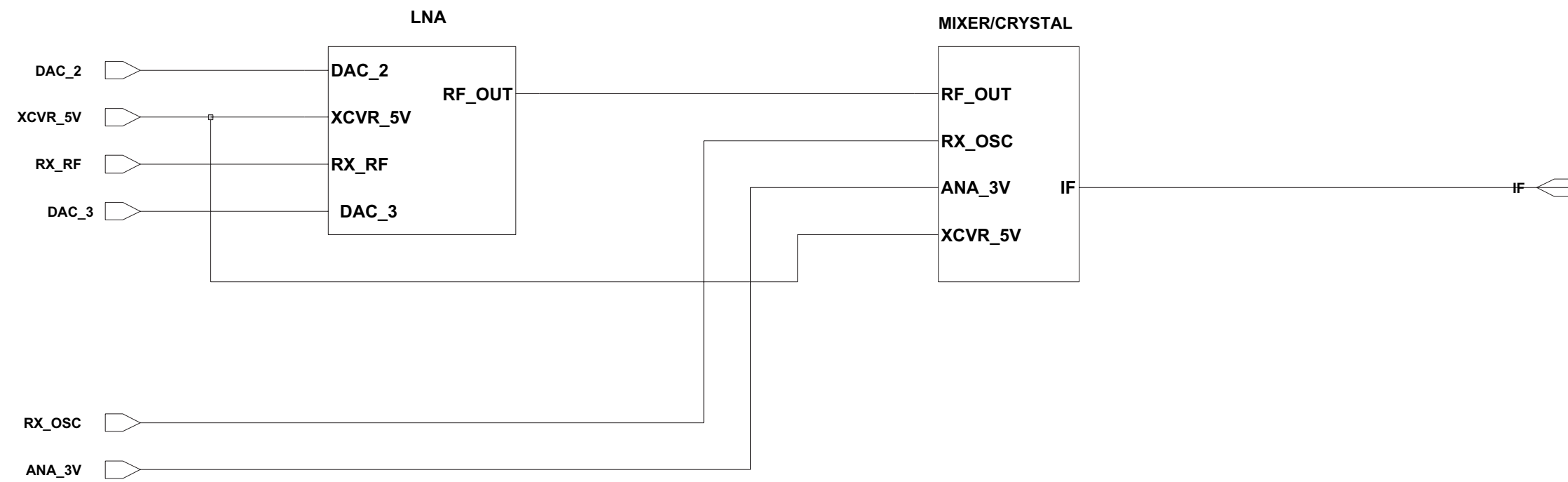

Figure 9.3-19. PMLE4427A/ PMLE4427B RX (front-end) Schematic

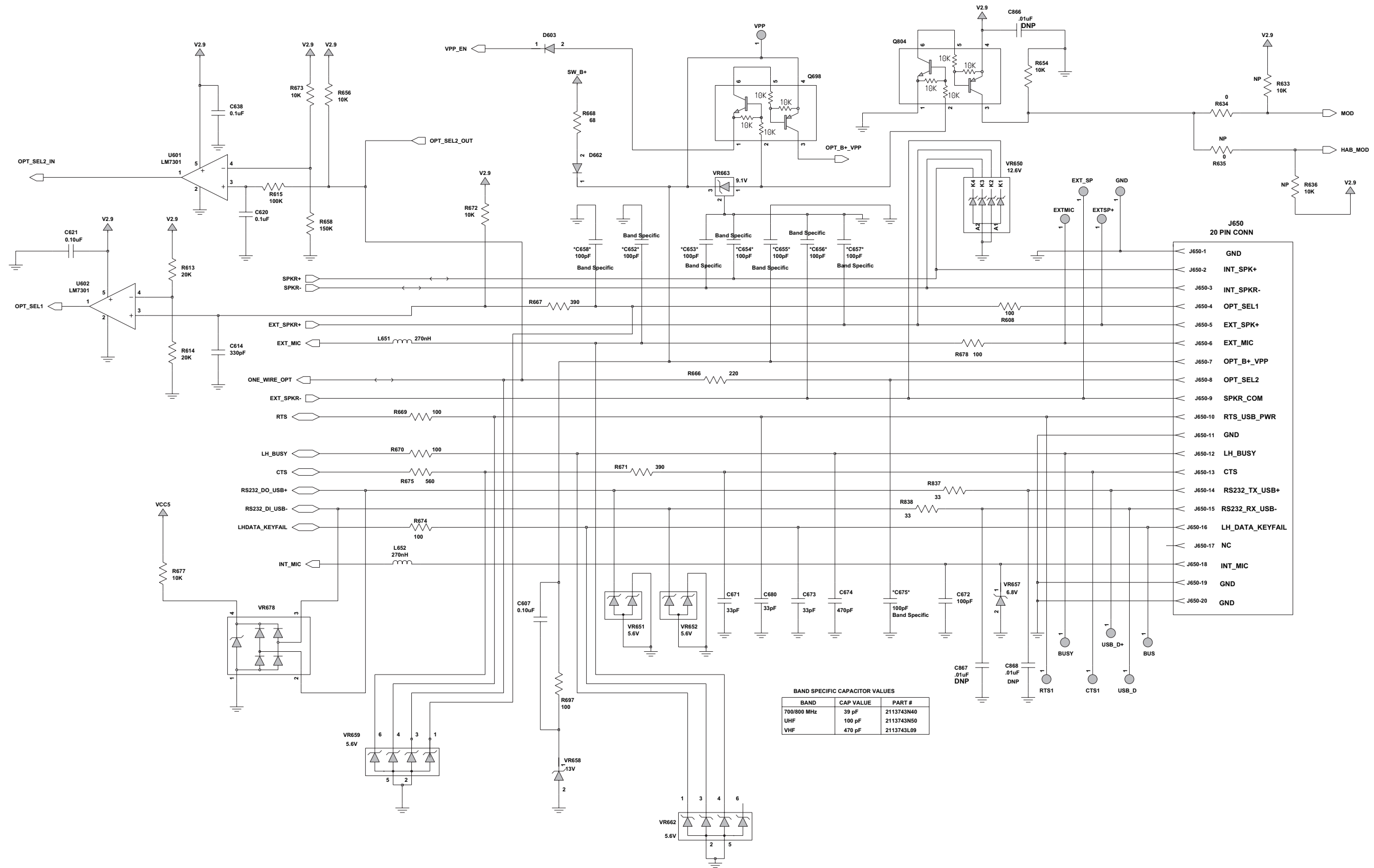

Figure 9.3-20. PMLE4427A/ PMLE4427B Side Connector Schematic

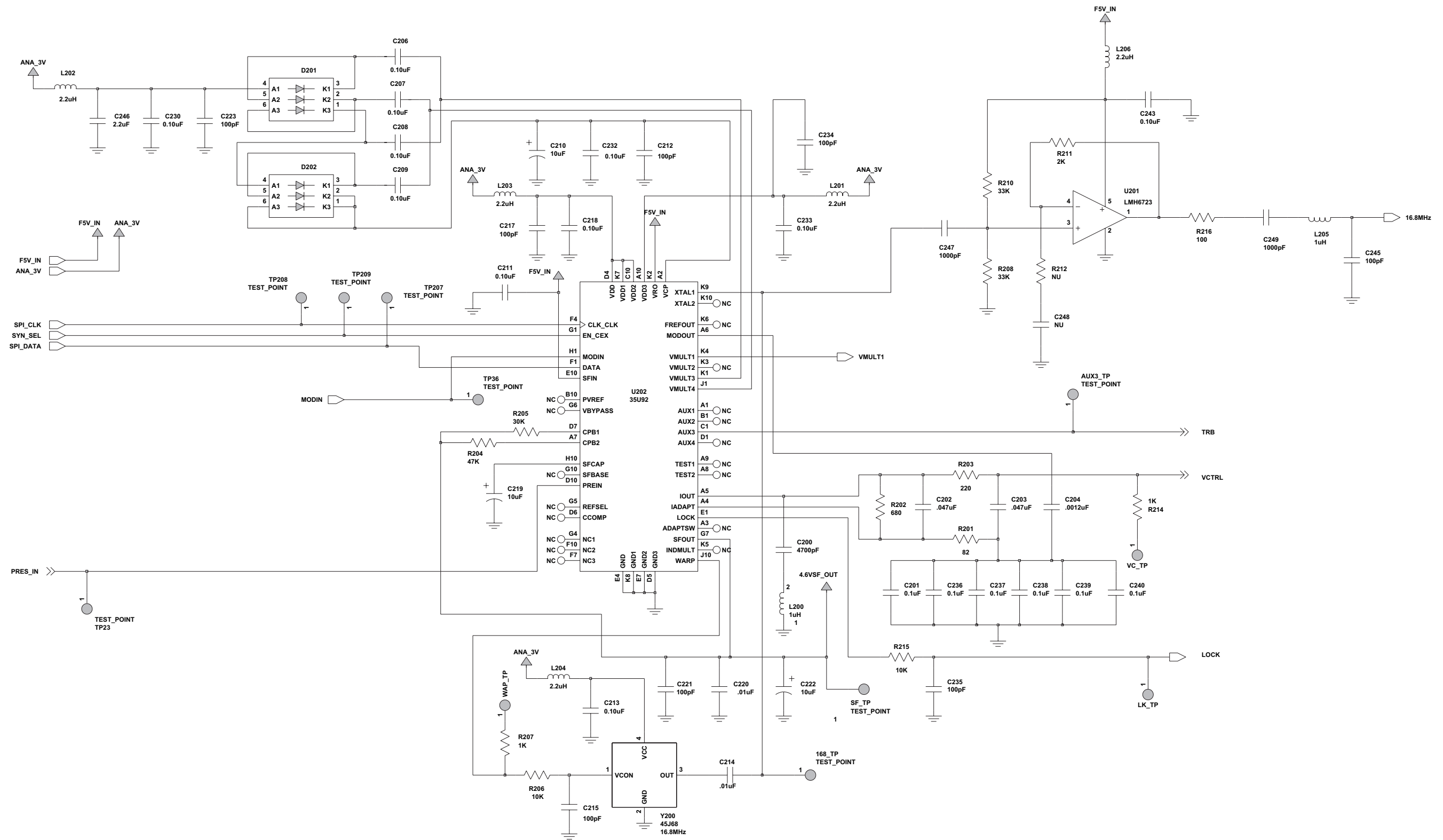

Figure 9.3-21. PMLE4427A Synthesizer Schematic

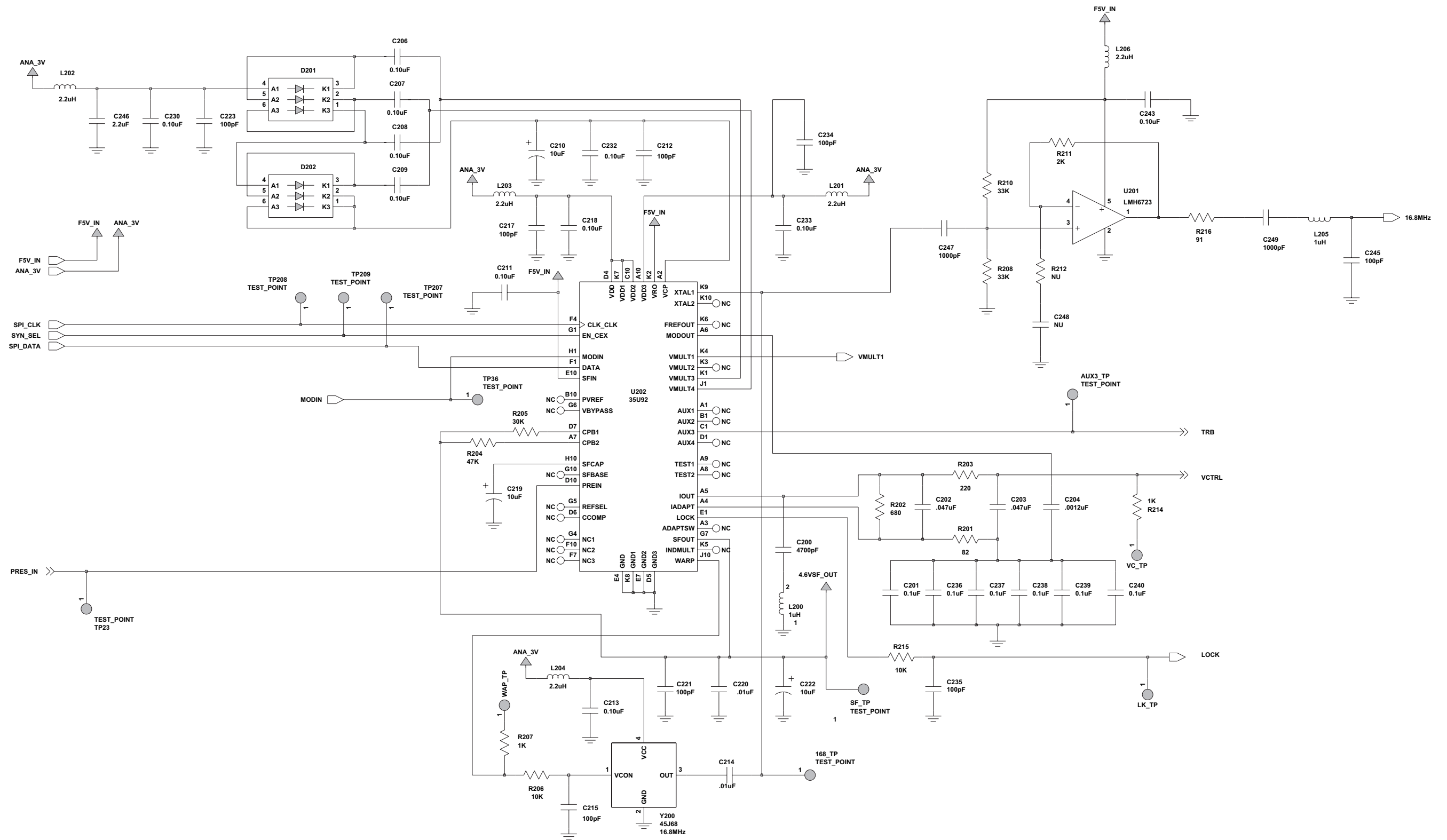

Figure 9.3-22. PMLE4427B Synthesizer Schematic

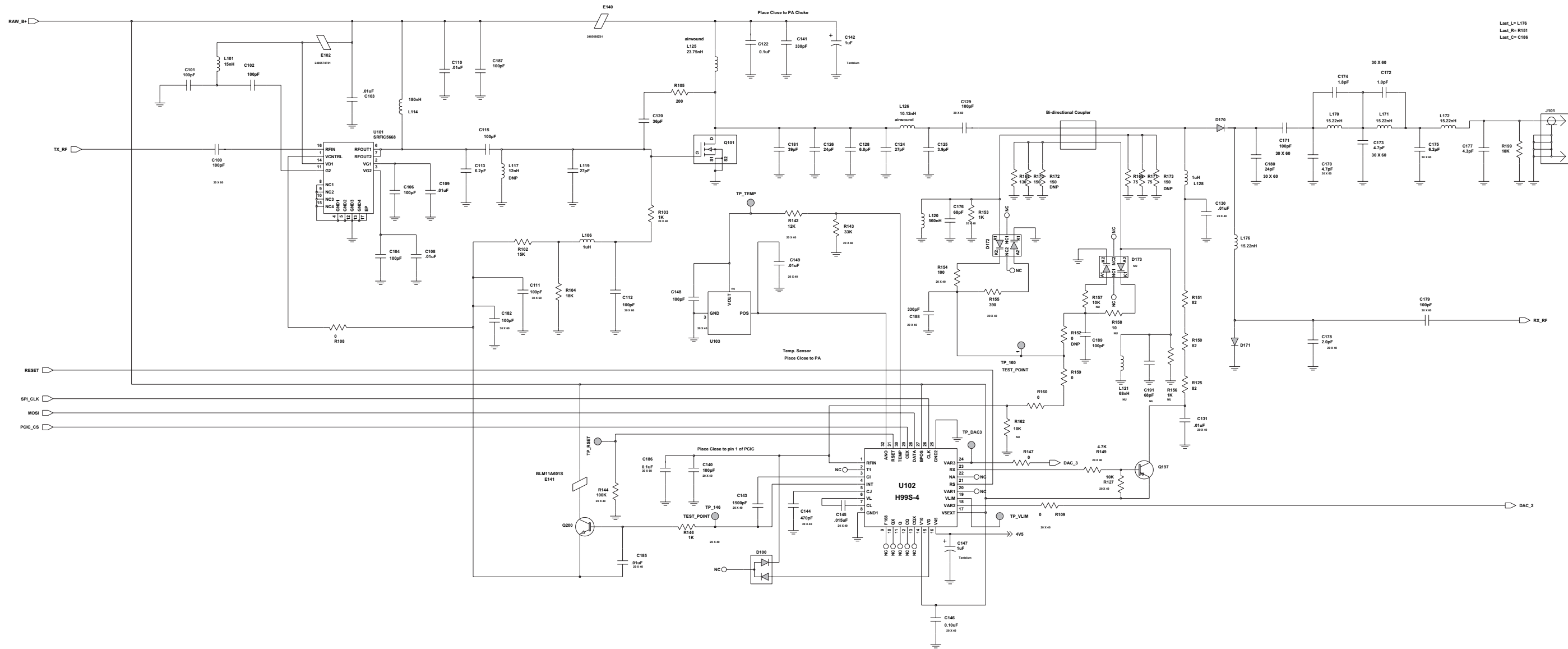

Figure 9.3-23. PMLE4427A/ PMLE4427B TX Schematic

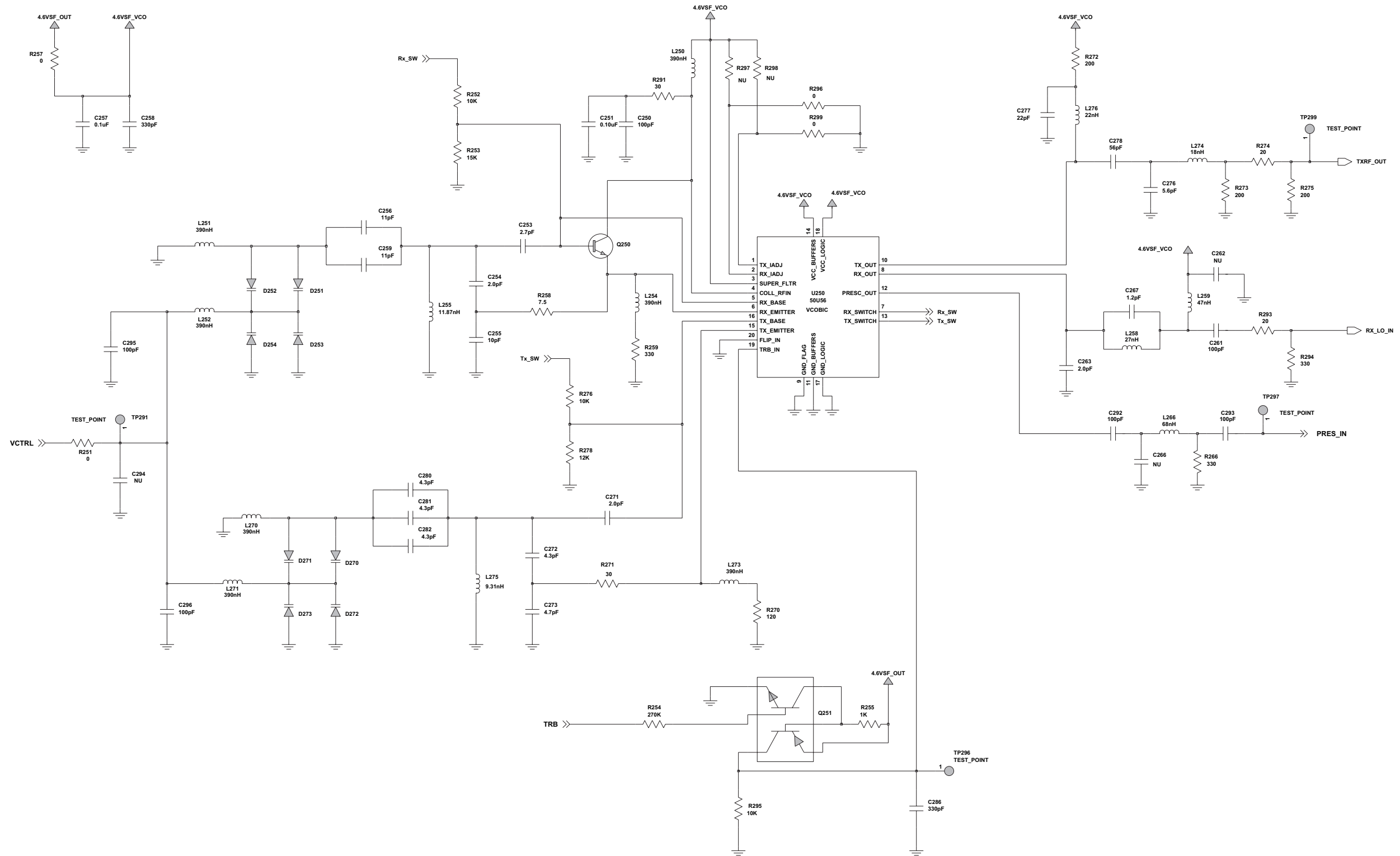

Figure 9.3-24. PMLE4427A/ PMLE4427B VCO Schematic

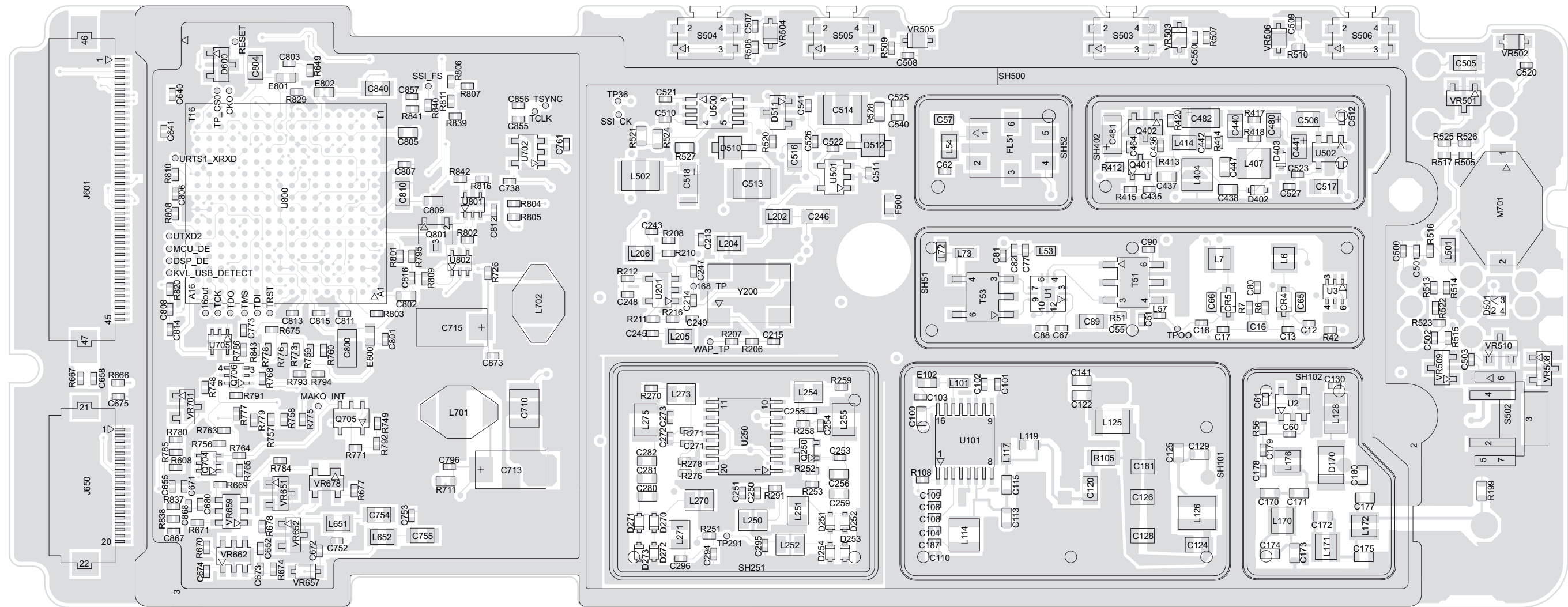

Figure 9.3-25. 8416852H01_A Top Overlay

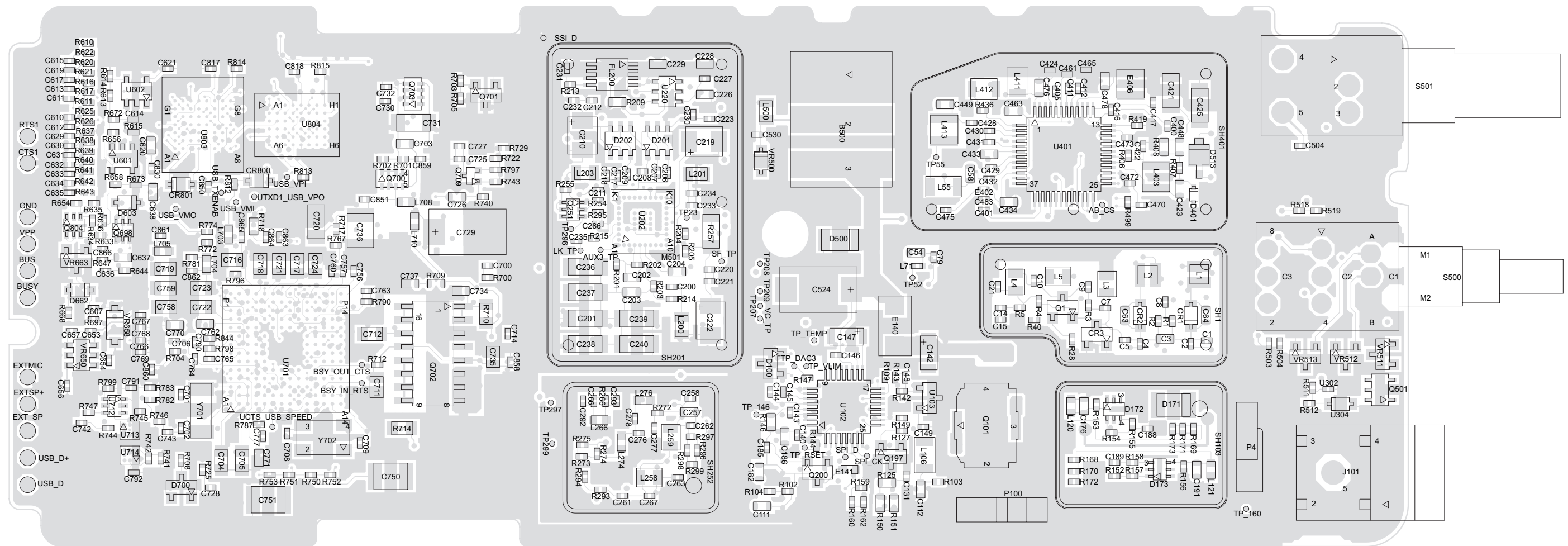

Figure 9.3-26. 8416852H01_A Bottom Overlay

PMLE4427A/ PMLE4427B Main Circuit Board
 Electrical Parts List

ITEM	MOTOROLA PART NUMBER	DESCRIPTION
PCB	8416852H01	BOARD, PC, UHF BAND 2
B500	0986237A02	CONNECTOR (CONTACT BATTERY)
C1	2113944A15	CAP CER CHP 3.9PF 50V +/- 0.25PF
C2	2113944A23	CAP CER CHP 8.2PF 50V +/- 0.5PF
C3	2113740F14	CAP CHIP REEL CL1 +/-30 3.0
C4	2113944A23	CAP CER CHP 8.2PF 50V +/- 0.5PF
C5	2113944A15	CAP CER CHP 3.9PF 50V +/- 0.25PF
C7	2113944A40	CAP CER CHP 100.0PF 50V 5%
C8	2113944A40	CAP CER CHP 100.0PF 50V 5%
C9	2113945B02	CAP CER CHP 10,000PF 25V 10%
C10	2113944A40	CAP CER CHP 100.0PF 50V 5%
C12	2113944A15	CAP CER CHP 3.9PF 50V +/- 0.25PF
C13	2113944A24	CAP CER CHP 9.1PF 50V +/- 0.5PF
C14	2113945Y02	CAP,FXD,.1UF,+10%,-10%,16V-DC,0402,X7R
C15	2113944A40	CAP CER CHP 100.0PF 50V 5%
C16	2113740F14	CAP CHIP REEL CL1 +/-30 3.0
C17	2113944A24	CAP CER CHP 9.1PF 50V +/- 0.5PF
C18	2113944A15	CAP CER CHP 3.9PF 50V +/- 0.25PF
C21	2113945B02	CAP CER CHP 10,000PF 25V 10%
C51	2113944A14	CAP CER CHP 3.6PF 50V +/- 0.25PF
C54	2113740F24	CAP CHIP REEL C1 +/-30 7.5
C55	2113945B02	CAP CER CHP 10,000PF 25V 10%
C57	2113944M12	CAP,FXD,5.6PF,.1PF+/-,50V-DC,0603
C58	2113944M07	CAP,FXD,3.6PF,.1PF+/-,50V-DC,0603

ITEM	MOTOROLA PART NUMBER	DESCRIPTION
C60	2113945Y02	CAP,FXD,.1UF,+10%,-10%,16V-DC,0402,X7R
C61	2113945A03	CAP CER CHP 330PF 50V 10%
C62	NOTPLACED	
C63	2113740F13	CAP CHIP REEL CL1 +/-30 2.7
C64	2113740F13	CAP CHIP REEL CL1 +/-30 2.7
C65	2113740F13	CAP CHIP REEL CL1 +/-30 2.7
C66	2113740F13	CAP CHIP REEL CL1 +/-30 2.7
C67	2113945B02	CAP CER CHP 10,000PF 25V 10%
C77	2113945B02	CAP CER CHP 10,000PF 25V 10%
C79	2113944A40	CAP CER CHP 100.0PF 50V 5%
C80	2113945B02	CAP CER CHP 10,000PF 25V 10%
C81	2113945A58	CAP,FXD,910PF,+10%,-10%,50V-DC,0402,X7R
C82	2113944A40	CAP CER CHP 100.0PF 50V 5%
C88	2113945B02	CAP CER CHP 10,000PF 25V 10%
C89	2113946F03	CAP CER CHP 4.7UF 6.3V 10%
C90	2113944A40	CAP CER CHP 100.0PF 50V 5%
C100	2113944C45	CAP CER CHP 100.0PF 50V 5%
C101	NOTPLACED	
C102	2113944A40	CAP CER CHP 100.0PF 50V 5%
C103	2113945B02	CAP CER CHP 10,000PF 25V 10%
C104	2113944A40	CAP CER CHP 100.0PF 50V 5%
C106	2113944A40	CAP CER CHP 100.0PF 50V 5%
C108	2113945B02	CAP CER CHP 10,000PF 25V 10%
C109	2113945B02	CAP CER CHP 10,000PF 25V 10%
C110	2113945B02	CAP CER CHP 10,000PF 25V 10%
C111	2113944C45	CAP CER CHP 100.0PF 50V 5%
C112	2113944C45	CAP CER CHP 100.0PF 50V 5%
C113	2113944C32	CAP CER CHP 15.0PF 50V 5%
C115	2113944C45	CAP CER CHP 100.0PF 50V 5%
C120	2113945C31	CAP,FXD,.1UF,+10%,-10%,50V-DC,0603,X7R

ITEM	MOTOROLA PART NUMBER	DESCRIPTION
C122	2113945C31	CAP,FXD,.1UF,+10%,-10%,50V-DC,0603,X7R
C124	2113944F50	CAP,FXD,22PF,+5%,-5%,50V-DC,0805
C125	2113944C20	CAP CER CHP 3.9PF 50V +/- 0.25PF
C126	2113944F51	CAP,FXD,24PF,+5%,-5%,50V-DC,0805
C128	2113944F42	CAP,FXD,10PF,+5%,-5%,50V-DC,0805
C129	2113944C45	CAP CER CHP 100.0PF 50V 5%
C130	2113945B02	CAP CER CHP 10,000PF 25V 10%
C131	2113945B02	CAP CER CHP 10,000PF 25V 10%
C140	2113944A40	CAP CER CHP 100.0PF 50V 5%
C141	2113944C45	CAP CER CHP 100.0PF 50V 5%
C142	2313960A76	CAP,FXD,1UF,+10%,-10%,20V-DC
C143	2113945A10	CAP CER CHP 1500PF 50V 10%
C144	2113945A05	CAP CER CHP 470PF 50V 10%
C145	2113945B03	CAP,FXD,.015UF,+10%,-10%,25V-DC,0402,X7R
C146	2113945Y02	CAP,FXD,.1UF,+10%,-10%,16V-DC,0402,X7R
C147	2313960A76	CAP,FXD,1UF,+10%,-10%,20V-DC
C148	2113944A40	CAP CER CHP 100.0PF 50V 5%
C149	2113945B02	CAP CER CHP 10,000PF 25V 10%
C170	2113944M10	CAP,FXD,4.7PF,.1PF+/-,50V-DC,0603
C171	2113944C45	CAP CER CHP 100.0PF 50V 5%
C172	2113944C63	CAP,FXD,1PF,.1PF+/-,50V-DC,0603
C173	2113944M10	CAP,FXD,4.7PF,.1PF+/-,50V-DC,0603
C174	2113944C69	CAP,FXD,1.8PF,.1PF+/-,50V-DC,0603
C175	2113944M13	CAP,FXD,6.2PF,.1PF+/-,50V-DC,0603
C176	2113944C30	CAP CER CHP 10.0PF 50V +/- 0.5PF

ITEM	MOTOROLA PART NUMBER	DESCRIPTION
C177	2113944M09	CAP,FXD,4.3PF,.1PF+/-,50V-DC,0603
C178	2113944A08	CAP CER CHP 2.0PF 50V +/- 0.25PF
C179	2113944A40	CAP CER CHP 100.0PF 50V 5%
C180	NOTPLACED	
C181	2113944F56	CAP,FXD,39PF,+5%,-5%,50V-DC,0805
C182	2113944C45	CAP CER CHP 100.0PF 50V 5%
C185	2113945B02	CAP CER CHP 10,000PF 25V 10%
C186	2113945C31	CAP,FXD,.1UF,+10%,-10%,50V-DC,0603,X7R
C187	2113944A40	CAP CER CHP 100.0PF 50V 5%
C188	2113944A40	CAP CER CHP 100.0PF 50V 5%
C189	2113944A40	CAP CER CHP 100.0PF 50V 5%
C191	NOTPLACED	
C200	2113945A13	CAP CER CHP 4700PF 50V 10%
C201	2185419D06	CAP CER SUPER L/D 0.1UF
C202	2113945C27	CAP,FXD,.047UF,+10%,-10%,50V-DC,0603,X7R
C203	2113945C27	CAP,FXD,.047UF,+10%,-10%,50V-DC,0603,X7R
C204	2185419D08	CAP CER SUPER L/D 0.0012UF
C206	2113945Y02	CAP,FXD,.1UF,+10%,-10%,16V-DC,0402,X7R
C207	2113945Y02	CAP,FXD,.1UF,+10%,-10%,16V-DC,0402,X7R
C208	2113945Y02	CAP,FXD,.1UF,+10%,-10%,16V-DC,0402,X7R
C209	2113945Y02	CAP,FXD,.1UF,+10%,-10%,16V-DC,0402,X7R
C210	2313960D07	CAP,FXD,10,+10,-10,16,SM
C211	2113945Y02	CAP,FXD,.1UF,+10%,-10%,16V-DC,0402,X7R
C212	2113944A40	CAP CER CHP 100.0PF 50V 5%
C213	2113945Y02	CAP,FXD,.1UF,+10%,-10%,16V-DC,0402,X7R
C214	2113945B02	CAP CER CHP 10,000PF 25V 10%
C215	2113944A40	CAP CER CHP 100.0PF 50V 5%
C217	2113944A40	CAP CER CHP 100.0PF 50V 5%

ITEM	MOTOROLA PART NUMBER	DESCRIPTION
C218	2113945Y02	CAP,FXD,.1UF,+10%,-10%,16V-DC,0402,X7R
C219	2313960D07	CAP,FXD,10,+10,-10,16,SM
C220	2113945B02	CAP CER CHP 10,000PF 25V 10%
C221	2113944A40	CAP CER CHP 100.0PF 50V 5%
C222	2313960D07	CAP,FXD,10,+10,-10,16,SM
C223	2113944A40	CAP CER CHP 100.0PF 50V 5%
C226	2113945C31	CAP,FXD,.1UF,+10%,-10%,50V-DC,0603,X7R
C227	2113944A40	CAP CER CHP 100.0PF 50V 5%
C228	2113945C31	CAP,FXD,.1UF,+10%,-10%,50V-DC,0603,X7R
C229	2113945C31	CAP,FXD,.1UF,+10%,-10%,50V-DC,0603,X7R
C230	2113945Y02	CAP,FXD,.1UF,+10%,-10%,16V-DC,0402,X7R
C231	2113945A01	CAP CER CHP 220PF 50V 10
C232	2113945Y02	CAP,FXD,.1UF,+10%,-10%,16V-DC,0402,X7R
C233	2113945Y02	CAP,FXD,.1UF,+10%,-10%,16V-DC,0402,X7R
C234	2113944A40	CAP CER CHP 100.0PF 50V 5%
C235	2113944A40	CAP CER CHP 100.0PF 50V 5%
C236	2185419D06	CAP CER SUPER L/D 0.1UF
C237	2185419D06	CAP CER SUPER L/D 0.1UF
C238	2185419D06	CAP CER SUPER L/D 0.1UF
C239	2185419D06	CAP CER SUPER L/D 0.1UF
C240	2185419D06	CAP CER SUPER L/D 0.1UF
C243	2113945Y02	CAP,FXD,.1UF,+10%,-10%,16V-DC,0402,X7R
C245	2113944A40	CAP CER CHP 100.0PF 50V 5%
C246	2113946N03	CAP CER CHP 2.2UF 16V
C247	2113945A09	CAP CER CHP 1000PF 50V 10%
C248	NOTPLACED	
C249	2113945A09	CAP CER CHP 1000PF 50V 10%
C250	2113944A40	CAP CER CHP 100.0PF 50V 5%
C251	2113945Y02	CAP,FXD,.1UF,+10%,-10%,16V-DC,0402,X7R
C253	2113944A11	CAP CER CHP 2.7PF 50V +/- 0.25PF

ITEM	MOTOROLA PART NUMBER	DESCRIPTION
C254	2113944A08	CAP CER CHP 2.0PF 50V +/- 0.25PF
C255	2113944A25	CAP CER CHP 10.0PF 50V +/- 0.5PF
C256	2113944C77	CAP,FXD,11PF,+5%,-5%,50V-DC,0603,C
C257	2113945C31	CAP,FXD,.1UF,+10%,-10%,50V-DC,0603,X7R
C258	2113945A03	CAP CER CHP 330PF 50V 10%
C259	2113944C77	CAP,FXD,11PF,+5%,-5%,50V-DC,0603,C
C261	2113944A40	CAP CER CHP 100.0PF 50V 5%
C262	NOTPLACED	
C263	2113944A08	CAP CER CHP 2.0PF 50V +/- 0.25PF
C266	NOTPLACED	
C267	2113944A02	CAP CER CHP 1.2PF 50V +/- 0.25PF
C271	2113944A08	CAP CER CHP 2.0PF 50V +/- 0.25PF
C272	2113944A16	CAP CER CHP 4.3PF 50V +/- 0.25PF
C273	2113944A17	CAP CER CHP 4.7PF 50V +/- 0.25PF
C276	2113944A19	CAP CER CHP 5.6PF 50V +/- 0.5PF
C277	2113944A29	CAP CER CHP 22.0PF 50V 5%
C278	2113944A34	CAP CER CHP 56.0PF 50V 5%
C280	2113944C21	CAP CER CHP 4.3PF 50V +/- 0.25PF
C281	2113944C21	CAP CER CHP 4.3PF 50V +/- 0.25PF
C282	2113944C21	CAP CER CHP 4.3PF 50V +/- 0.25PF
C286	2113945A03	CAP CER CHP 330PF 50V 10%
C292	2113944A40	CAP CER CHP 100.0PF 50V 5%
C293	2113944A40	CAP CER CHP 100.0PF 50V 5%
C294	NOTPLACED	
C295	2113944A40	CAP CER CHP 100.0PF 50V 5%
C296	2113944A40	CAP CER CHP 100.0PF 50V 5%
C400	2113944A40	CAP CER CHP 100.0PF 50V 5%

ITEM	MOTOROLA PART NUMBER	DESCRIPTION
C401	2113945Y02	CAP,FXD,.1UF,+10%,-10%,16V-DC,0402,X7R
C405	2113944A40	CAP CER CHP 100.0PF 50V 5%
C411	2113945A11	CAP CER CHP 2200PF 50V 10%
C412	NOTPLACED	
C416	2113945Y02	CAP,FXD,.1UF,+10%,-10%,16V-DC,0402,X7R
C417	2113944A40	CAP CER CHP 100.0PF 50V 5%
C421	NOTPLACED	
C422	2113945B02	CAP CER CHP 10,000PF 25V 10%
C423	2113944C41	CAP CER CHP 68.0PF 50V 5%
C424	2113944A40	CAP CER CHP 100.0PF 50V 5%
C425	2113945H69	CAP,FXD,.1UF,+5%,-5%,50V-DC,1206,X7R
C428	2113945B02	CAP CER CHP 10,000PF 25V 10%
C429	2113945Y02	CAP,FXD,.1UF,+10%,-10%,16V-DC,0402,X7R
C430	2113945Y02	CAP,FXD,.1UF,+10%,-10%,16V-DC,0402,X7R
C431	2113945Y02	CAP,FXD,.1UF,+10%,-10%,16V-DC,0402,X7R
C432	2113945Y02	CAP,FXD,.1UF,+10%,-10%,16V-DC,0402,X7R
C433	2113944C33	CAP CER CHP 18.0PF 50V 5%
C434	2113945C27	CAP,FXD,.047UF,+10%,-10%,50V-DC,0603,X7R
C435	2113944A34	CAP CER CHP 56.0PF 50V 5%
C436	2113944A34	CAP CER CHP 56.0PF 50V 5%
C437	2113944C72	CAP,FXD,6.2PF,.25PF+/-,50V-DC,0603
C438	2113944C79	CAP,FXD,16PF,+5%,-5%,50V-DC,0603
C440	2113945G96	CAP,FXD,.33UF,+10%,-10%,50V-DC,0805,X7R
C441	2313960M26	CAP,FXD,1UF,+10%,-10%,10V-DC
C442	2113945B02	CAP CER CHP 10,000PF 25V 10%
C447	NOTPLACED	

ITEM	MOTOROLA PART NUMBER	DESCRIPTION
C448	2113945C25	CAP,FXD,.033UF,+10%,-10%,50V-DC,0603,X7R
C449	2113944C75	CAP,FXD,8.2PF,.25PF+/-,50V-DC,0603
C461	2113945Y02	CAP,FXD,.1UF,+10%,-10%,16V-DC,0402,X7R
C463	2113945C27	CAP,FXD,.047UF,+10%,-10%,50V-DC,0603,X7R
C464	2113945Y02	CAP,FXD,.1UF,+10%,-10%,16V-DC,0402,X7R
C465	2113945Y02	CAP,FXD,.1UF,+10%,-10%,16V-DC,0402,X7R
C470	2113945Y02	CAP,FXD,.1UF,+10%,-10%,16V-DC,0402,X7R
C472	2113945Y02	CAP,FXD,.1UF,+10%,-10%,16V-DC,0402,X7R
C473	2113945Y02	CAP,FXD,.1UF,+10%,-10%,16V-DC,0402,X7R
C475	NOTPLACED	
C476	2113944C89	CAP,FXD,200PF,+5%,-5%,50V-DC,0603
C478	2113945C27	CAP,FXD,.047UF,+10%,-10%,50V-DC,0603,X7R
C480	2313960M26	CAP,FXD,1UF,+10%,-10%,10V-DC
C481	2313960B30	CAP,FXD,4.7UF,+10%,-10%,10V-DC
C482	2313960B30	CAP,FXD,4.7UF,+10%,-10%,10V-DC
C483	NOTPLACED	
C500	2113945A05	CAP CER CHP 470PF 50V 10%
C501	2113945A05	CAP CER CHP 470PF 50V 10%
C502	2113945A05	CAP CER CHP 470PF 50V 10%
C503	2113945A05	CAP CER CHP 470PF 50V 10%
C504	2113945A05	CAP CER CHP 470PF 50V 10%
C505	2113945G98	CAP,FXD,.47UF,+10%,-10%,50V-DC,0805,X7R
C506	2113946E02	CAP CER CHP 1.0UF 16V 10%
C507	2113945B02	CAP CER CHP 10,000PF 25V 10%
C508	2113945B02	CAP CER CHP 10,000PF 25V 10%

ITEM	MOTOROLA PART NUMBER	DESCRIPTION
C509	2113945B02	CAP CER CHP 10,000PF 25V 10%
C510	2113945Y02	CAP,FXD,.1UF,+10%,-10%,16V-DC,0402,X7R
C511	2113945Y02	CAP,FXD,.1UF,+10%,-10%,16V-DC,0402,X7R
C512	2113945Y02	CAP,FXD,.1UF,+10%,-10%,16V-DC,0402,X7R
C513	2113955E37	CAP,FXD,10UF,+10%,-10%,16V-DC,1210,X7R
C514	2113955E37	CAP,FXD,10UF,+10%,-10%,16V-DC,1210,X7R
C516	2113946E02	CAP CER CHP 1.0UF 16V 10%
C517	2113946E02	CAP CER CHP 1.0UF 16V 10%
C518	2313960B57	CAP,FXD,10UF,+10%,-10%,6.3V-DC
C520	2113944A40	CAP CER CHP 100.0PF 50V 5%
C521	2113945B02	CAP CER CHP 10,000PF 25V 10%
C522	2113945B02	CAP CER CHP 10,000PF 25V 10%
C523	2113945B02	CAP CER CHP 10,000PF 25V 10%
C524	2314030U26	CAP,FXD,10UF,+10%,-10%,35V-DC
C525	2113944A38	CAP CER CHP 82.0PF 50V 5%
C526	2113944A38	CAP CER CHP 82.0PF 50V 5%
C527	2113944A40	CAP CER CHP 100.0PF 50V 5%
C530	2113944A40	CAP CER CHP 100.0PF 50V 5%
C540	2113944A45	CAP CER CHP 270.0 PF 50V 5%
C541	2113944A45	CAP CER CHP 270.0 PF 50V 5%
C550	2113945B02	CAP CER CHP 10,000PF 25V 10%
C607	2113945Y02	CAP,FXD,.1UF,+10%,-10%,16V-DC,0402,X7R
C610	2113944A32	CAP CER CHP 39.0PF 50V 5%
C611	2113944A32	CAP CER CHP 39.0PF 50V 5%
C612	2113944A32	CAP CER CHP 39.0PF 50V 5%
C613	2113944A32	CAP CER CHP 39.0PF 50V 5%
C614	2113945A03	CAP CER CHP 330PF 50V 10%
C615	2113944A32	CAP CER CHP 39.0PF 50V 5%

ITEM	MOTOROLA PART NUMBER	DESCRIPTION
C617	2113944A32	CAP CER CHP 39.0PF 50V 5%
C619	2113944A32	CAP CER CHP 39.0PF 50V 5%
C620	2113945C31	CAP,FXD,.1UF,+10%,-10%,50V-DC,0603,X7R
C621	2113945Y02	CAP,FXD,.1UF,+10%,-10%,16V-DC,0402,X7R
C629	2113944A40	CAP CER CHP 100.0PF 50V 5%
C630	2113944A40	CAP CER CHP 100.0PF 50V 5%
C631	2113944A40	CAP CER CHP 100.0PF 50V 5%
C632	2113944A40	CAP CER CHP 100.0PF 50V 5%
C633	2113944A40	CAP CER CHP 100.0PF 50V 5%
C634	2113944A40	CAP CER CHP 100.0PF 50V 5%
C635	2113944A40	CAP CER CHP 100.0PF 50V 5%
C636	2113944A40	CAP CER CHP 100.0PF 50V 5%
C637	2113945L49	CAP,FXD,.01UF,+5%,-5%,50V-DC,0603,X7R
C638	2113945C31	CAP,FXD,.1UF,+10%,-10%,50V-DC,0603,X7R
C640	NOTPLACED	
C641	NOTPLACED	
C652	2113944A40	CAP CER CHP 100.0PF 50V 5%
C653	2113944A40	CAP CER CHP 100.0PF 50V 5%
C654	2113944A40	CAP CER CHP 100.0PF 50V 5%
C655	2113944A40	CAP CER CHP 100.0PF 50V 5%
C656	2113944A40	CAP CER CHP 100.0PF 50V 5%
C657	2113944A40	CAP CER CHP 100.0PF 50V 5%
C658	2113944A40	CAP CER CHP 100.0PF 50V 5%
C671	2113944A31	CAP CER CHP 33.0PF 50V 5%
C672	2113944A40	CAP CER CHP 100.0PF 50V 5%
C673	2113944A31	CAP CER CHP 33.0PF 50V 5%
C674	2113945A05	CAP CER CHP 470PF 50V 10%
C675	2113944A40	CAP CER CHP 100.0PF 50V 5%
C680	2113944A31	CAP CER CHP 33.0PF 50V 5%
C700	2113946B04	CAP CER CHP 0.10UF 10V 10%
C701	2113944A19	CAP CER CHP 5.6PF 50V +/- 0.5PF
C702	2113944A19	CAP CER CHP 5.6PF 50V +/- 0.5PF
C703	NOTPLACED	

ITEM	MOTOROLA PART NUMBER	DESCRIPTION
C704	2113946F01	CAP CER CHP 2.2UF 6.3V 10%
C705	2113946F01	CAP CER CHP 2.2UF 6.3V 10%
C706	2113945A09	CAP CER CHP 1000PF 50V 10%
C708	2113944A31	CAP CER CHP 33.0PF 50V 5%
C709	2113944A31	CAP CER CHP 33.0PF 50V 5%
C710	2113946J03	CAP CER CHP 10.0UF 16V 10%
C711	2113946F03	CAP CER CHP 4.7UF 6.3V 10%
C712	2113946E02	CAP CER CHP 1.0UF 16V 10%
C713	2314030F31	CAP,FXD,68UF,+10%,-10%,10V-DC
C714	2113945A09	CAP CER CHP 1000PF 50V 10%
C715	2314030F31	CAP,FXD,68UF,+10%,-10%,10V-DC
C716	2113946F01	CAP CER CHP 2.2UF 6.3V 10%
C717	2113946E02	CAP CER CHP 1.0UF 16V 10%
C718	2113946F01	CAP CER CHP 2.2UF 6.3V 10%
C719	2113946E02	CAP CER CHP 1.0UF 16V 10%
C720	2113946G01	CAP CER CHP 2.2UF 16V 10%
C721	2113946E02	CAP CER CHP 1.0UF 16V 10%
C722	2113946E02	CAP CER CHP 1.0UF 16V 10%
C723	2113946E02	CAP CER CHP 1.0UF 16V 10%
C724	2113946E02	CAP CER CHP 1.0UF 16V 10%
C725	2113945Y02	CAP,FXD,.1UF,+10%,-10%,16V-DC,0402,X7R
C726	2113740A79	CAP CHIP REEL CL1 +/-30 1000
C727	2113944A40	CAP CER CHP 100.0PF 50V 5%
C728	2113944A40	CAP CER CHP 100.0PF 50V 5%
C729	2314030U26	CAP,FXD,10UF,+10%,-10%,35V-DC
C730	2113944A40	CAP CER CHP 100.0PF 50V 5%
C731	2113946G01	CAP CER CHP 2.2UF 16V 10%
C732	2113944A40	CAP CER CHP 100.0PF 50V 5%
C734	2113945C31	CAP,FXD,.1UF,+10%,-10%,50V-DC,0603,X7R
C735	2113946E02	CAP CER CHP 1.0UF 16V 10%
C736	2113946J03	CAP CER CHP 10.0UF 16V 10%
C737	2113945C31	CAP,FXD,.1UF,+10%,-10%,50V-DC,0603,X7R
C738	2113945Y02	CAP,FXD,.1UF,+10%,-10%,16V-DC,0402,X7R

ITEM	MOTOROLA PART NUMBER	DESCRIPTION
C742	2113945A05	CAP CER CHP 470PF 50V 10%
C743	2113944A25	CAP CER CHP 10.0PF 50V +/- 0.5PF
C750	2113946J03	CAP CER CHP 10.0UF 16V 10%
C751	2113946J03	CAP CER CHP 10.0UF 16V 10%
C752	2113944A40	CAP CER CHP 100.0PF 50V 5%
C753	2113944A40	CAP CER CHP 100.0PF 50V 5%
C754	2113946E02	CAP CER CHP 1.0UF 16V 10%
C755	2113946E02	CAP CER CHP 1.0UF 16V 10%
C756	2113944A40	CAP CER CHP 100.0PF 50V 5%
C757	2113944A40	CAP CER CHP 100.0PF 50V 5%
C758	2113946E02	CAP CER CHP 1.0UF 16V 10%
C759	2113946E02	CAP CER CHP 1.0UF 16V 10%
C760	2113944A40	CAP CER CHP 100.0PF 50V 5%
C761	2113944A40	CAP CER CHP 100.0PF 50V 5%
C762	2113945C31	CAP,FXD,.1UF,+10%,-10%,50V-DC,0603,X7R
C763	2113944A40	CAP CER CHP 100.0PF 50V 5%
C764	2113946B03	CAP CER CHP 0.068UF 10V 10
C765	2113946B03	CAP CER CHP 0.068UF 10V 10
C766	2113944A40	CAP CER CHP 100.0PF 50V 5%
C767	2113944A40	CAP CER CHP 100.0PF 50V 5%
C768	2113944A40	CAP CER CHP 100.0PF 50V 5%
C769	2113944A40	CAP CER CHP 100.0PF 50V 5%
C770	2113945C31	CAP,FXD,.1UF,+10%,-10%,50V-DC,0603,X7R
C771	2113945C31	CAP,FXD,.1UF,+10%,-10%,50V-DC,0603,X7R
C773	2113945Y02	CAP,FXD,.1UF,+10%,-10%,16V-DC,0402,X7R
C777	2113944A40	CAP CER CHP 100.0PF 50V 5%
C790	2113946A02	CAP CER CHP 0.022UF 16V 10
C791	2113945Y02	CAP,FXD,.1UF,+10%,-10%,16V-DC,0402,X7R
C792	2113945Y02	CAP,FXD,.1UF,+10%,-10%,16V-DC,0402,X7R
C796	2113944A40	CAP CER CHP 100.0PF 50V 5%
C800	2113955D31	CAP,FXD,1UF,+10%,-10%,16V-DC,1206,X7R
C801	2113944A40	CAP CER CHP 100.0PF 50V 5%

ITEM	MOTOROLA PART NUMBER	DESCRIPTION
C802	2113945C20	CAP,FXD,.016UF,+10%,-10%,50V-DC,0603,X7R
C803	2113944A40	CAP CER CHP 100.0PF 50V 5%
C804	2113946E02	CAP CER CHP 1.0UF 16V 10%
C805	2113945C20	CAP,FXD,.016UF,+10%,-10%,50V-DC,0603,X7R
C806	2113945Y02	CAP,FXD,.1UF,+10%,-10%,16V-DC,0402,X7R
C807	2113945Y02	CAP,FXD,.1UF,+10%,-10%,16V-DC,0402,X7R
C808	2113945Y02	CAP,FXD,.1UF,+10%,-10%,16V-DC,0402,X7R
C809	2113945C20	CAP,FXD,.016UF,+10%,-10%,50V-DC,0603,X7R
C810	2113946E02	CAP CER CHP 1.0UF 16V 10%
C811	2113945Y02	CAP,FXD,.1UF,+10%,-10%,16V-DC,0402,X7R
C812	2113945Y02	CAP,FXD,.1UF,+10%,-10%,16V-DC,0402,X7R
C813	2113945Y02	CAP,FXD,.1UF,+10%,-10%,16V-DC,0402,X7R
C814	2113945Y02	CAP,FXD,.1UF,+10%,-10%,16V-DC,0402,X7R
C815	2113945Y02	CAP,FXD,.1UF,+10%,-10%,16V-DC,0402,X7R
C816	2113945Y02	CAP,FXD,.1UF,+10%,-10%,16V-DC,0402,X7R
C817	2113945Y02	CAP,FXD,.1UF,+10%,-10%,16V-DC,0402,X7R
C818	2113945Y02	CAP,FXD,.1UF,+10%,-10%,16V-DC,0402,X7R
C830	2113945Y02	CAP,FXD,.1UF,+10%,-10%,16V-DC,0402,X7R
C840	2113946F03	CAP CER CHP 4.7UF 6.3V 10%
C850	2113945A03	CAP CER CHP 330PF 50V 10%
C851	2113944A40	CAP CER CHP 100.0PF 50V 5%
C855	NOTPLACED	
C856	NOTPLACED	
C857	NOTPLACED	
C858	2113945B02	CAP CER CHP 10,000PF 25V 10%
C859	2113945B02	CAP CER CHP 10,000PF 25V 10%

ITEM	MOTOROLA PART NUMBER	DESCRIPTION
C860	2113945B02	CAP CER CHP 10,000PF 25V 10%
C861	2113945B02	CAP CER CHP 10,000PF 25V 10%
C862	2113945B02	CAP CER CHP 10,000PF 25V 10%
C863	2113945B02	CAP CER CHP 10,000PF 25V 10%
C864	2113945B02	CAP CER CHP 10,000PF 25V 10%
C865	2113945B02	CAP CER CHP 10,000PF 25V 10%
C866	2113945B02	CAP CER CHP 10,000PF 25V 10%
C867	NOTPLACED	
C868	NOTPLACED	
C873	NOTPLACED	
CR1	4805656W90	DIODE V.1SV304(TPH3,F)SOD323 NOPB
CR2	4805656W90	DIODE V.1SV304(TPH3,F)SOD323 NOPB
CR3	4815048H01	SOT MMBD353 DIODE DUAL SHT
CR4	4805656W90	DIODE V.1SV304(TPH3,F)SOD323 NOPB
CR5	4805656W90	DIODE V.1SV304(TPH3,F)SOD323 NOPB
CR800	4813978A25	SCHOTTKY 30V SOD-323 T&R PB FREE
CR801	4813978A25	SCHOTTKY 30V SOD-323 T&R PB FREE
D100	NOTPLACED	
D170	4802482J02	PIN DIODE SMD
D171	4802482J02	PIN DIODE SMD
D172	4813978A26	DIODE ARRAY,DET,SOT-363/SC-88,30V,.12W
D173	4813978A26	DIODE ARRAY,DET,SOT-363/SC-88,30V,.12W
D201	4815011H01	DIODE TRIPLE
D202	4815011H01	DIODE TRIPLE

ITEM	MOTOROLA PART NUMBER	DESCRIPTION
D251	4805656W87	DIODE,VCTR, @ 15V,1SV279,SOD-523/SC-79
D252	4805656W87	DIODE,VCTR, @ 15V,1SV279,SOD-523/SC-79
D253	4805656W87	DIODE,VCTR, @ 15V,1SV279,SOD-523/SC-79
D254	4805656W87	DIODE,VCTR, @ 15V,1SV279,SOD-523/SC-79
D270	4805656W87	DIODE,VCTR, @ 15V,1SV279,SOD-523/SC-79
D271	4805656W87	DIODE,VCTR, @ 15V,1SV279,SOD-523/SC-79
D272	4805656W87	DIODE,VCTR, @ 15V,1SV279,SOD-523/SC-79
D273	4805656W87	DIODE,VCTR, @ 15V,1SV279,SOD-523/SC-79
D401	4805656W87	DIODE,VCTR, @ 15V,1SV279,SOD-523/SC-79
D402	4815096H01	VARACTOR DIODE 1SV305
D403	4815096H01	VARACTOR DIODE 1SV305
D500	4815155H01	RECTIFIER
D501	4809118D02	LED BICOLOR LNJ115W8POMT
D510	4813978M15	DIODE,RECT,1A,40V,PB-FREE, NOTCOMPLETELYENRICHED
D511	4813978B18	DIODE,SWG,BAT54,SM,SOT-23,200MA,30V,.2W,SHTK,PB-FREE
D512	4813978M15	DIODE,RECT,1A,40V,PB-FREE, NOTCOMPLETELYENRICHED
D513	4813978M15	DIODE,RECT,1A,40V,PB-FREE, NOTCOMPLETELYENRICHED
D600	4813978B18	DIODE,SWG,BAT54,SM,SOT-23,200MA,30V,.2W,SHTK,PB-FREE
D603	4813978A25	SCHOTTKY 30V SOD-323 T&R PB FREE
D662	4813978A25	SCHOTTKY 30V SOD-323 T&R PB FREE
D700	4813978B18	DIODE,SWG,BAT54,SM,SOT-23,200MA,30V,.2W,SHTK,PB-FREE
E102	2480574F01	IND FERRITE CHIP 60OHM 0603
E140	2405688Z01	INDUCTOR FERRITE BEAD

ITEM	MOTOROLA PART NUMBER	DESCRIPTION
E141	2480574F01	IND FERRITE CHIP 60OHM 0603
E402	2480640Z01	SURFACE MOUNT FERRITE BEAD
E406	2414032B76	IDCTR,WW,4.7UH,5%,330MA,4 OHM,CER,20 Q,60MHZ SRF,SM
E800	2480574F01	IND FERRITE CHIP 60OHM 0603
E801	2480574F01	IND FERRITE CHIP 60OHM 0603
E802	0613952G67	CER CHIP RES 0.0 +/-0.050 OHM
F500	6515076H01	FUSE CHIP SMT TR/1608FF 3A
FL200	9116848H01	FLTR SW CAP 3 POLE BUTTERW, W18
FL51	9185924B01	FILTER, 73.35 MHZ 3-POLE CRYST
J101	2880658Z08	CONNECTOR SMA
J601	0916287H01	CONN VERT 45 PIN ZIF
J650	0916287H02	CONN 20 PIN ZIF
L1	2471406L01	RF AIR WOUND COIL 8.9NH
L2	2471406L01	RF AIR WOUND COIL 8.9NH
L3	2414032F26	IDCTR,WW,22NH,5%,500MA,.22 OHM,CER,45 Q,2.2GHZ SRF,SM,PB-FRE
L4	2414032F37	IDCTR,WW,180NH,5%,400MA,.6 4OHM,CER,35 Q,710MHZ SRF,SM,PB-FR
L5	2414032F23	IDCTR,WW,12NH,5%,600MA,.15 OHM,CER,45 Q,2.75GHZ SRF,SM
L6	2471406L01	RF AIR WOUND COIL 8.9NH
L7	2471406L01	RF AIR WOUND COIL 8.9NH
L53	2415429H43	CHIP INDUCTOR 220nH
L54	2414017K32	IDCTR,CHIP,560NH,5%,50MA,5 OHM,CER,11Q,150MHZSRF,SM, 0805,PB-F
L55	2414032D25	IDCTR,WW,620NH,5%,400MA,1. 6OHM,CER,28Q,400MHZSRF,S M,LEAD-FR
L57	2113944A78	CAP,FXD,13PF,+5%,-5%,50V-DC,0402

ITEM	MOTOROLA PART NUMBER	DESCRIPTION
L71	2414017P16	IDCTR,CHIP,18NH,5%,300MA,.7 6OHM,CER,9 Q,1.9GHZ SRF,SM,0402,P
L72	2415429H38	CHIP INDUCTOR 120nH
L73	2415429H47	CHIP INDUCTOR 390nH
L101	2414017G09	IDCTR,CHIP,15NH,5%,300MA,.4 5OHM,CER,8Q,SM,0603,PB-FREE
L106	2414032D30	IDCTR,WW,1UH,5%,320MA,2.8 OHM,CER,28 Q,340MHZ SRF,SM,LEAD-FR
L114	2414032B56	IDCTR,WW,180NH,5%,750MA,.7 7OHM,CER,25 Q,700MHZ SRF,SM
L117	NOTPLACED	
L119	2113944C35	CAP CER CHP 27.0PF 50V 5%
L120	2485930A10	IND 18.0NH 5%
L121	NOTPLACED	
L125	2479990C03	AIR WOUND COIL/GREEN COLOR 13.85NH
L126	2460591L05	COIL AIR WOUND INDUC 10.12
L128	2414032D30	IDCTR,WW,1UH,5%,320MA,2.8 OHM,CER,28 Q,340MHZ SRF,SM,LEAD-FR
L170	2460591B48	COIL AIR WOUND INDUC 15.22
L171	2460591B48	COIL AIR WOUND INDUC 15.22
L172	2460591B48	COIL AIR WOUND INDUC 15.22
L176	2460591B48	COIL AIR WOUND INDUC 15.22
L200	2414017Q47	IDCTR,FXD,1UH,10%,50MA,.45 OHM,FERR,45 Q,75MHZ SRF,SM,0805,PB
L201	2414017Q20	IDCTR,FXD,2.2UH,20%,30MA,.6 5OHM,FERR,45Q,50MHZSRF,SM,0805
L202	2414017Q20	IDCTR,FXD,2.2UH,20%,30MA,.6 5OHM,FERR,45Q,50MHZSRF,SM,0805
L203	2414017Q20	IDCTR,FXD,2.2UH,20%,30MA,.6 5OHM,FERR,45Q,50MHZSRF,SM,0805
L204	2414017Q20	IDCTR,FXD,2.2UH,20%,30MA,.6 5OHM,FERR,45Q,50MHZSRF,SM,0805

ITEM	MOTOROLA PART NUMBER	DESCRIPTION
L205	2414017Q47	IDCTR,FXD,1UH,10%,50MA,.45 OHM,FERR,45 Q,75MHZ SRF,SM,0805,PB
L206	2414017Q20	IDCTR,FXD,2.2UH,20%,30MA,.6 5OHM,FERR,45Q,50MHZSRF,SM,0805
L250	2414032F41	IDCTR,WW,390NH,10%,200MA,1.5OHM,CER,40 Q,730MHZ SRF,SM,LEAD
L251	2414032F41	IDCTR,WW,390NH,10%,200MA,1.5OHM,CER,40 Q,730MHZ SRF,SM,LEAD
L252	2414032F41	IDCTR,WW,390NH,10%,200MA,1.5OHM,CER,40 Q,730MHZ SRF,SM,LEAD
L254	2414032F41	IDCTR,WW,390NH,10%,200MA,1.5OHM,CER,40 Q,730MHZ SRF,SM,LEAD
L255	2460591C03	COIL AIR WOUND INDUC 11.87
L258	2414032F27	IDCTR,FXD,27NH,5%,500MA,.2 5OHM,CER,45 Q,2GHZ SRF,SM,0805
L259	2414032F30	IDCTR,WW,47NH,5%,500MA,.31 OHM,CER,40 Q,1.4GHZ SRF,SM,LE
L266	2414017N19	IDCTR,CHIP,39NH,5%,500MA,.7 4OHM,CER,15 Q,1GHZ SRF,SM,0603,PB
L270	2414032F41	IDCTR,WW,390NH,10%,200MA,1.5OHM,CER,40 Q,730MHZ SRF,SM,LEAD
L271	2414032F41	IDCTR,WW,390NH,10%,200MA,1.5OHM,CER,40 Q,730MHZ SRF,SM,LEAD
L273	2414032F41	IDCTR,WW,390NH,10%,200MA,1.5OHM,CER,40 Q,730MHZ SRF,SM,LEAD
L274	2415429H20	CHIP INDUCTOR 18nH
L275	2460591C02	COIL AIR WOUND INDUC 9.31
L276	2415429H21	CHIP INDUCTOR 22nH
L403	2414032B75	IDCTR,WW,3.9UH,5%,340MA,3.6OHM,CER,20Q,70MHZSRF,SM,LEAD-FRE
L404	2414032B59	IDCTR,WW,330NH,5%,690MA,1.05OHM,CER,30Q,500MHZSRF,SM,LEAD-F

ITEM	MOTOROLA PART NUMBER	DESCRIPTION
L407	2414032B76	IDCTR,WW,4.7UH,5%,330MA,4 OHM,CER,20 Q,60MHZ SRF,SM
L411	2466505A01	COIL INDUCTOR 10uH
L412	2466505A01	COIL INDUCTOR 10uH
L413	2414032B59	IDCTR,WW,330NH,5%,690MA,1.05OHM,CER,30Q,500MHZSRF,SM,LEAD-F
L414	2414017Q51	IDCTR,FXD,2.2UH,10%,30MA,.6 5OHM,FERR,45 Q,50MHZ SRF,SM,0805
L500	2414017Q42	IDCTR,FXD,390NH,10%,200MA,.65OHM,FERR,25Q,135MHZSRF,SM,0805
L501	2414017Q51	IDCTR,FXD,2.2UH,10%,30MA,.6 5OHM,FERR,45 Q,50MHZ SRF,SM,0805
L502	2489669V01	IDCTR,WW,100UH,5%,40MA,10 OHM,20 Q,10MHZ SRF,SM,1210,PB-FREE
L651	2414032F75	IDCTR,WW,270NH,2%,350MA,1 OHM,CER,48 Q,650MHZ SRF,SM,0805
L652	2414032F75	IDCTR,WW,270NH,2%,350MA,1 OHM,CER,48 Q,650MHZ SRF,SM,0805
L701	2486085A01	COIL, POWER INDUCTOR
L702	2486085A01	COIL, POWER INDUCTOR
L703	2464675H01	IDCTR,WW,560NH,5%,550MA
L704	2464675H01	IDCTR,WW,560NH,5%,550MA
L705	2464675H01	IDCTR,WW,560NH,5%,550MA
L708	2416307H01	IDCTR,WW,680NH,5%,0603
L710	2416307H01	IDCTR,WW,680NH,5%,0603
M501	NOTPLACED	
M701	0985888K02	SKT RTC BTTY LEAP
P4	3905643V01	CONTACT ANT GRD
P100	3916333H02	GROUND CONTACT
Q1	4816531H01	NPN SILICON BIPOLAR TRANSISTOR
Q101	4816698H03	mitsubishi RD09MUP2-T112 UHF RFPA
Q197	4813973A13	XSTR,BIP GP SS,PNP,TO-236,SOT-23,SMT,40V,.225W,200MA,250M

ITEM	MOTOROLA PART NUMBER	DESCRIPTION
Q200	4871674S01	XSTR,BIP GP SS
Q250	4805218N63	RF TRANS SOT 323 BFQ67W
Q251	4816371H01	XSTR DUAL PNP W18 COMPLIANT
Q401	4805585Q28	TRANSISTOR RF NPN 8GHZ NOPB
Q402	4813973A04	XSTR,BIP GP SS,NPN,TA13,SM,SOT-23,SMT,30V,.225W,300MA,125MHZ
Q501	4805921T28	XSTR, DUAL NOPB
Q698	4813973A81	XSTR,BIP GP SS,DIG,NPN AND PNP,SOT-363,50V,.25W,100MA,BIAS
Q700	4813970A62	XSTR,FET GP PWR,MOSFET,P-CH,ENHN,CF,-20V,1.3W,PB-FREE
Q701	4813973M07	XSTR,BIP GP SS,NPN,TO-236,SMT,40V,.225W,200MA,300MHZ,PB-FREE
Q702	5185956E76	IC,CONV,SM,SO16,0-30 VINPUT RANGE,6.5A,3.8V,HI SPD SWTH DR
Q703	4813970A62	XSTR,FET GP PWR,MOSFET,P-CH,ENHN,CF,-20V,1.3W,PB-FREE
Q704	NOTPLACED	
Q705	NOTPLACED	
Q706	NOTPLACED	
Q709	4885061Y01	XSTR NPN 6V 30UA 12GHZ PB-FREE
Q801	4813973A42	XSTR,BIP GP SS,NPN,SM,SC-59,SMT,50V,.23W,BIAS RSTR. TRANS
Q804	4813973A81	XSTR,BIP GP SS,DIG,NPN AND PNP,SOT-363,50V,.25W,100MA,BIAS
R1	0613952R25	CER CHIP RES 100K OHM 5% 0402
R2	0613952R25	CER CHIP RES 100K OHM 5% 0402
R3	0613952Q73	CER CHIP RES 1000 OHM 5 0402
R4	0613952R03	CER CHIP RES 12K OHM 5% 0402

ITEM	MOTOROLA PART NUMBER	DESCRIPTION
R5	0613952Q65	CER CHIP RES 470 OHM 5 0402
R6	0613952R25	CER CHIP RES 100K OHM 5% 0402
R7	0613952R25	CER CHIP RES 100K OHM 5% 0402
R28	0613952Q09	CER CHIP RES 2.2 OHM 5 0402
R40	0613952Q95	CER CHIP RES 8200 OHM 5 0402
R42	0613952R25	CER CHIP RES 100K OHM 5% 0402
R51	0613952Q46	CER CHIP RES 75.0 OHM 5 0402
R56	NOTPLACED	
R102	0613952R05	CER CHIP RES 15K OHM 5% 0402
R103	0613952Q73	CER CHIP RES 1000 OHM 5 0402
R104	0613952R07	CER CHIP RES 18K OHM 5% 0402
R105	0613952H55	CER CHIP RES 180 OHM 5% 0603
R108	0613952R66	CER CHIP RES 0.0 +/-0.050 OHM
R109	0613952R66	CER CHIP RES 0.0 +/-0.050 OHM
R125	0613952H47	CER CHIP RES 82.0 OHM 5 0603
R127	0613952R01	CER CHIP RES 10K OHM 5% 0402
R142	0613952Z63	RES,MF,36KOHM,1%,.0625W,S M,0402,200PPM/CEL,PB-FREE
R143	0613952Z64	RES,MF,39KOHM,1%,.0625W,S M,0402
R144	0613952R25	CER CHIP RES 100K OHM 5% 0402
R146	0613952H73	CER CHIP RES 1000 OHM 5% 0603
R147	0613952R66	CER CHIP RES 0.0 +/-0.050 OHM
R149	0613952Q89	CER CHIP RES 4700 OHM 5 0402
R150	0613952H47	CER CHIP RES 82.0 OHM 5 0603

ITEM	MOTOROLA PART NUMBER	DESCRIPTION
R151	0613952H47	CER CHIP RES 82.0 OHM 5 0603
R152	NOTPLACED	
R153	NOTPLACED	
R154	0613952Q49	CER CHIP RES 100 OHM 5 0402
R155	0613952Q68	CER CHIP RES 620 OHM 5 0402
R156	NOTPLACED	
R157	NOTPLACED	
R158	NOTPLACED	
R159	0613952R66	CER CHIP RES 0.0 +/-0.050 OHM
R160	0613952R66	CER CHIP RES 0.0 +/-0.050 OHM
R162	NOTPLACED	
R168	0613952Q52	CER CHIP RES 130 OHM 5 0402
R169	0613952Q46	CER CHIP RES 75.0 OHM 5 0402
R170	0613952Q53	CER CHIP RES 150 OHM 5 0402
R171	0613952Q46	CER CHIP RES 75.0 OHM 5 0402
R172	NOTPLACED	
R173	NOTPLACED	
R199	0613952J01	CER CHIP RES 10K OHM 5% 0603
R201	0613952Q47	CER CHIP RES 82.0 OHM 5% 0402
R202	0613952Q69	CER CHIP RES 680 OHM 5 0402
R203	0613952Q57	CER CHIP RES 220 OHM 5 0402
R204	0613952R17	CER CHIP RES 47K OHM 5% 0402
R205	0613952R12	CER CHIP RES 30K OHM 5 0402
R206	0613952R01	CER CHIP RES 10K OHM 5% 0402
R207	0613952Q73	CER CHIP RES 1000 OHM 5 0402
R208	0613952R13	CER CHIP RES 33K OHM 5% 0402
R209	0613952G67	CER CHIP RES 0.0 +/-0.050 OHM
R210	0613952R13	CER CHIP RES 33K OHM 5% 0402

ITEM	MOTOROLA PART NUMBER	DESCRIPTION
R211	0613952Q80	CER CHIP RES 2000 OHM 5 0402
R212	NOTPLACED	
R213	0613952Q95	CER CHIP RES 8200 OHM 5 0402
R214	0613952Q73	CER CHIP RES 1000 OHM 5 0402
R215	0613952R01	CER CHIP RES 10K OHM 5% 0402
R216	0613952Q49 (PMLE4427A) 0613952K93 (PMLE4427B)	CER CHIP RES 100 OHM 5 0402 CER CHIP RES 91 OHM 5 0402
R251	0613952R66	CER CHIP RES 0.0 +/-0.050 OHM
R252	0613952R01	CER CHIP RES 10K OHM 5% 0402
R253	0613952R05	CER CHIP RES 15K OHM 5% 0402
R254	0613952R35	CER CHIP RES 270K OHM 5% 0402
R255	0613952Q73	CER CHIP RES 1000 OHM 5 0402
R257	0613958T74	CER CHIP RES 0.0 OHM JMP 1206
R258	0613952Q22	CER CHIP RES 7.5 OHM 5 0402
R259	0613952Q61	CER CHIP RES 330 OHM 5 0402
R266	2113944V03	CAP,FXD,1PF,.1PF+/-,50V-DC,0402,C0G,-55DEG CMIN,125DEG CMAX,PB
R270	0613952Q51	CER CHIP RES 120 OHM 5 0402
R271	0613952Q36	CER CHIP RES 30.0 OHM 5 0402
R272	0613952Q56	CER CHIP RES 200 OHM 5 0402
R273	0613952Q56	CER CHIP RES 200 OHM 5 0402
R274	0613952Q32	CER CHIP RES 20.0 OHM 5 0402
R275	0613952Q56	CER CHIP RES 200 OHM 5 0402
R276	0613952R01	CER CHIP RES 10K OHM 5% 0402
R278	0613952R03	CER CHIP RES 12K OHM 5% 0402

ITEM	MOTOROLA PART NUMBER	DESCRIPTION
R291	0613952Q36	CER CHIP RES 30.0 OHM 5 0402
R293	0613952Q32	CER CHIP RES 20.0 OHM 5 0402
R294	0613952Q61	CER CHIP RES 330 OHM 5 0402
R295	0613952R01	CER CHIP RES 10K OHM 5% 0402
R296	0613952R66	CER CHIP RES 0.0 +/-0.050 OHM
R297	NOTPLACED	
R298	NOTPLACED	
R299	0613952R66	CER CHIP RES 0.0 +/-0.050 OHM
R406	0613952R01	CER CHIP RES 10K OHM 5% 0402
R407	0613952R01	CER CHIP RES 10K OHM 5% 0402
R408	0613952H79	CER CHIP RES 1800 OHM 5% 0603
R412	0613952H55	CER CHIP RES 180 OHM 5% 0603
R413	0613952H61	CER CHIP RES 330 OHM 5 0603
R414	0613952R01	CER CHIP RES 10K OHM 5% 0402
R415	0613952R01	CER CHIP RES 10K OHM 5% 0402
R417	0613952Q74	RES,MF,1.1KOHM,5%,.0625W,S M,0402,200PPM/CEL,PB-FREE
R418	0613952R66	CER CHIP RES 0.0 +/-0.050 OHM
R419	0613952R25	CER CHIP RES 100K OHM 5% 0402
R420	0613952R19	CER CHIP RES 56K OHM 5% 0402
R436	0613952R66	CER CHIP RES 0.0 +/-0.050 OHM
R499	0613952R01	CER CHIP RES 10K OHM 5% 0402
R503	0613952Q63	CER CHIP RES 390 OHM 5 0402
R504	0613952Q66	CER CHIP RES 510 OHM 5 0402

ITEM	MOTOROLA PART NUMBER	DESCRIPTION
R505	0613952R01 (PMLE4427A)	CER CHIP RES 10K OHM 5% 0402
	0613952Q93 (PMLE4427B)	CER CHIP RES 6.8K OHM 5% 0402
R507	0613952Q49	CER CHIP RES 100 OHM 5 0402
R508	0613952Q49	CER CHIP RES 100 OHM 5 0402
R509	0613952Q49	CER CHIP RES 100 OHM 5 0402
R510	0613952Q49	CER CHIP RES 100 OHM 5 0402
R511	0613952R01	CER CHIP RES 10K OHM 5% 0402
R512	0613952R17	CER CHIP RES 47K OHM 5% 0402
R513	0613952R01	CER CHIP RES 10K OHM 5% 0402
R514	0613952R01	CER CHIP RES 10K OHM 5% 0402
R515	0613952R01	CER CHIP RES 10K OHM 5% 0402
R516	0613952R01	CER CHIP RES 10K OHM 5% 0402
R517	0613952R01	CER CHIP RES 10K OHM 5% 0402
R518	0613952R01	CER CHIP RES 10K OHM 5% 0402
R519	0613952R17	CER CHIP RES 47K OHM 5% 0402
R520	0613952R37	CER CHIP RES 330K OHM 5% 0402
R521	NOTPLACED	
R522	0613952R17	CER CHIP RES 47K OHM 5% 0402
R523	0613952R17	CER CHIP RES 47K OHM 5% 0402
R524	0613952G67	CER CHIP RES 0.0 +/-0.050 OHM
R525	0613952R01	CER CHIP RES 10K OHM 5% 0402
R526	0613952R01	CER CHIP RES 10K OHM 5% 0402
R527	NOTPLACED	
R528	0613952G67	CER CHIP RES 0.0 +/-0.050 OHM
R608	0613952Q49	CER CHIP RES 100 OHM 5 0402

ITEM	MOTOROLA PART NUMBER	DESCRIPTION
R610	NOTPLACED	
R611	0613952Q49	CER CHIP RES 100 OHM 5 0402
R613	0613952R08	CER CHIP RES 20K OHM 5 0402
R614	0613952R08	CER CHIP RES 20K OHM 5 0402
R615	0613952R25	CER CHIP RES 100K OHM 5% 0402
R616	0613952Q49	CER CHIP RES 100 OHM 5 0402
R617	NOTPLACED	
R620	0613952Q49	CER CHIP RES 100 OHM 5 0402
R621	0613952Q49	CER CHIP RES 100 OHM 5 0402
R622	0613952Q49	CER CHIP RES 100 OHM 5 0402
R625	0613952Q49	CER CHIP RES 100 OHM 5 0402
R626	0613952Q49	CER CHIP RES 100 OHM 5 0402
R633	NOTPLACED	
R634	0613952R66	CER CHIP RES 0.0 +/-0.050 OHM
R635	NOTPLACED	
R636	0613952R01	CER CHIP RES 10K OHM 5% 0402
R637	0613952Q49	CER CHIP RES 100 OHM 5 0402
R638	0613952Q49	CER CHIP RES 100 OHM 5 0402
R639	0613952Q49	CER CHIP RES 100 OHM 5 0402
R640	0613952Q49	CER CHIP RES 100 OHM 5 0402
R641	0613952Q49	CER CHIP RES 100 OHM 5 0402
R642	0613952Q49	CER CHIP RES 100 OHM 5 0402
R643	0613952Q49	CER CHIP RES 100 OHM 5 0402
R644	0613952Q49	CER CHIP RES 100 OHM 5 0402
R647	0613952R01	CER CHIP RES 10K OHM 5% 0402
R649	0613952R17	CER CHIP RES 47K OHM 5% 0402
R654	0613952R01	CER CHIP RES 10K OHM 5% 0402
R656	0613952R01	CER CHIP RES 10K OHM 5% 0402
R658	0613952P18	CER CHIP RES 150K OHM 1 0402
R666	0613952Q42	CER CHIP RES 51.0 OHM 5% 0402

ITEM	MOTOROLA PART NUMBER	DESCRIPTION
R667	0613952Q63	CER CHIP RES 390 OHM 5 0402
R668	0613952Q45	CER CHIP RES 68.0 OHM 5 0402
R669	0613952Q49	CER CHIP RES 100 OHM 5 0402
R670	0613952Q49	CER CHIP RES 100 OHM 5 0402
R671	0613952Q63	CER CHIP RES 390 OHM 5 0402
R672	0613952R01	CER CHIP RES 10K OHM 5% 0402
R673	0613952R01	CER CHIP RES 10K OHM 5% 0402
R674	0613952Q49	CER CHIP RES 100 OHM 5 0402
R675	0613952Q67	CER CHIP RES 560 OHM 5 0402
R677	0613952R01	CER CHIP RES 10K OHM 5% 0402
R678	0613952Q49	CER CHIP RES 100 OHM 5 0402
R697	0613952Q49	CER CHIP RES 100 OHM 5 0402
R700	0613952Q80	CER CHIP RES 2000 OHM 5 0402
R701	0613952R17	CER CHIP RES 47K OHM 5% 0402
R702	0613952R66	CER CHIP RES 0.0 +/-0.050 OHM
R703	0613952R17	CER CHIP RES 47K OHM 5% 0402
R704	0613952Q49	CER CHIP RES 100 OHM 5 0402
R705	0613952R17	CER CHIP RES 47K OHM 5% 0402
R708	0613952R19	CER CHIP RES 56K OHM 5% 0402
R709	0613952H17	CER CHIP RES 4.7OHM 5%
R710	0688044N04	RES,METAL STRIP, 0.1 OHM,1%,0.125W,SMD,0805
R711	0613952G67	CER CHIP RES 0.0 +/-0.050 OHM
R712	0613952Q49	CER CHIP RES 100 OHM 5 0402
R714	0688044N04	RES,METAL STRIP, 0.1 OHM,1%,0.125W,SMD,0805
R717	0613952R66	CER CHIP RES 0.0 +/-0.050 OHM
R718	0613952G67	CER CHIP RES 0.0 +/-0.050 OHM

ITEM	MOTOROLA PART NUMBER	DESCRIPTION
R722	0613952R08	CER CHIP RES 20K OHM 5 0402
R725	0613952R66	CER CHIP RES 0.0 +/-0.050 OHM
R726	0613952R66	CER CHIP RES 0.0 +/-0.050 OHM
R729	0613952R13	CER CHIP RES 33K OHM 5% 0402
R740	0613952Q63	CER CHIP RES 390 OHM 5 0402
R741	0613952R17	CER CHIP RES 47K OHM 5% 0402
R742	0613952R17	CER CHIP RES 47K OHM 5% 0402
R743	NOTPLACED	
R744	NOTPLACED	
R745	0613952R56	CER CHIP RES 2.0M OHM 5 0402
R746	0613952R56	CER CHIP RES 2.0M OHM 5 0402
R747	0613952Q73	CER CHIP RES 1000 OHM 5 0402
R748	0613952R41	CER CHIP RES 470K OHM 5% 0402
R749	0613952R41	CER CHIP RES 470K OHM 5% 0402
R750	0613952Q63	CER CHIP RES 390 OHM 5 0402
R751	0613952Q63	CER CHIP RES 390 OHM 5 0402
R752	0613952Q81	CER CHIP RES 2200 OHM 5 0402
R753	0613952Q81	CER CHIP RES 2200 OHM 5 0402
R756	0613952R66	CER CHIP RES 0.0 +/-0.050 OHM
R757	0613952R08	CER CHIP RES 20K OHM 5 0402
R758	0613952R19	CER CHIP RES 56K OHM 5% 0402
R759	0613952R01	CER CHIP RES 10K OHM 5% 0402
R760	0613952Q93	CER CHIP RES 6800 OHM 5 0402
R763	NOTPLACED	
R764	NOTPLACED	

ITEM	MOTOROLA PART NUMBER	DESCRIPTION
R765	NOTPLACED	
R767	0613952R66	CER CHIP RES 0.0 +/-0.050 OHM
R768	NOTPLACED	
R771	NOTPLACED	
R772	0613952Q49	CER CHIP RES 100 OHM 5 0402
R773	0613952Q49	CER CHIP RES 100 OHM 5 0402
R774	0613952Q49	CER CHIP RES 100 OHM 5 0402
R775	0613952Q49	CER CHIP RES 100 OHM 5 0402
R776	NOTPLACED	
R777	0613952R01	CER CHIP RES 10K OHM 5% 0402
R778	0613952R01	CER CHIP RES 10K OHM 5% 0402
R779	0613952R01	CER CHIP RES 10K OHM 5% 0402
R780	0613952Q89	CER CHIP RES 4700 OHM 5 0402
R781	0613952R01	CER CHIP RES 10K OHM 5% 0402
R782	0613952R01	CER CHIP RES 10K OHM 5% 0402
R783	0613952R01	CER CHIP RES 10K OHM 5% 0402
R784	NOTPLACED	
R785	0613952Q49	CER CHIP RES 100 OHM 5 0402
R786	0613952R17	CER CHIP RES 47K OHM 5% 0402
R787	0613952R66	CER CHIP RES 0.0 +/-0.050 OHM
R790	0613952R19	CER CHIP RES 56K OHM 5% 0402
R791	0613952R66	CER CHIP RES 0.0 +/-0.050 OHM
R792	0613952R66	CER CHIP RES 0.0 +/-0.050 OHM
R793	0613952R66	CER CHIP RES 0.0 +/-0.050 OHM
R794	0613952R66	CER CHIP RES 0.0 +/-0.050 OHM
R795	0613952R17	CER CHIP RES 47K OHM 5% 0402

ITEM	MOTOROLA PART NUMBER	DESCRIPTION
R796	0613952R66	CER CHIP RES 0.0 +/-0.050 OHM
R797	0613952Q41	CER CHIP RES 47.0 OHM 5 0402
R798	0613952Q61	CER CHIP RES 330 OHM 5 0402
R799	0613952R01	CER CHIP RES 10K OHM 5% 0402
R801	NOTPLACED	
R802	0613952Q49	CER CHIP RES 100 OHM 5 0402
R803	0613952Q49	CER CHIP RES 100 OHM 5 0402
R804	0613952Q66	CER CHIP RES 510 OHM 5 0402
R805	0613952R01	CER CHIP RES 10K OHM 5% 0402
R806	0613952Q66	CER CHIP RES 510 OHM 5 0402
R807	0613952R01	CER CHIP RES 10K OHM 5% 0402
R808	0613952R66	CER CHIP RES 0.0 +/-0.050 OHM
R809	0613952R17	CER CHIP RES 47K OHM 5% 0402
R810	0613952R01	CER CHIP RES 10K OHM 5% 0402
R811	0613952Q66	CER CHIP RES 510 OHM 5 0402
R812	0613952R25	CER CHIP RES 100K OHM 5% 0402
R813	0613952R66	CER CHIP RES 0.0 +/-0.050 OHM
R814	NOTPLACED	
R815	0613952R66	CER CHIP RES 0.0 +/-0.050 OHM
R816	0613952R17	CER CHIP RES 47K OHM 5% 0402
R820	0613952R01	CER CHIP RES 10K OHM 5% 0402
R829	NOTPLACED	
R837	0613952Q37	CER CHIP RES 33.0 OHM 5 0402
R838	0613952Q37	CER CHIP RES 33.0 OHM 5 0402
R839	0613952R01	CER CHIP RES 10K OHM 5% 0402
R840	0613952Q66	CER CHIP RES 510 OHM 5 0402

ITEM	MOTOROLA PART NUMBER	DESCRIPTION
R841	0613952R01	CER CHIP RES 10K OHM 5% 0402
R842	0613952R01	CER CHIP RES 10K OHM 5% 0402
R843	0613952R41	CER CHIP RES 470K OHM 5% 0402
R844	0613952Q61	CER CHIP RES 330 OHM 5 0402
S500	4085131E03	SWITCH FREQ DUAL FUNCTION
S501	1880619Z06	POTENTIOMETER, VOLUME
S502	4016618H01	SWITCH SURFACE MOUNT
S503	4070354A01	LIGHT TOUCH SWITCH-SMD
S504	4070354A01	LIGHT TOUCH SWITCH-SMD
S505	4070354A01	LIGHT TOUCH SWITCH-SMD
S506	4070354A01	LIGHT TOUCH SWITCH-SMD
SH1	2686707Z02	SHIELD, SM SLDRD,CRS,PLTD
SH51	2686700Z02	SHIELD, SM SLDRD,CRS,PLTD
SH52	2686699Z02	SHIELD, SM SLDRD,CRS,PLTD
SH101	2686702Z02	SHIELD, SM SLDRD,CRS,PLTD
SH102	2686701Z02	SHIELD, SM SLDRD,CRS,PLTD
SH103	2686708Z02	SHIELD, SM SLDRD,CRS,PLTD
SH201	2686705Z02	SHIELD, SM SLDRD,CRS,PLTD
SH251	2616554H01	SHLD VCO TOP
SH252	2616559H01	SHLD PCIC
SH401	2686706Z02	SHIELD, SM SLDRD,CRS,PLTD
SH402	2686698Z02	SHIELD, SM SLDRD,CRS,PLTD
SH500	NOTPLACED	
T51	2515121H01	BALUN, TRANSFORMER W18 COMP
T53	2516320H01	XFMR SMALL SIGNAL SURFACE MT
U1	5164015H81	IC,MXR,DBL BAL GILBERT,CELL,SM
U2	5185941F45	ATTEN,VAR,14.4DBMIN,15.6DB MAX,0-2000 MHZFREQ,50OHM,PCMT
U3	5116349H01	DUAL INVERTER IC
U101	5115678H01	VHF/UHF/800/900 MHZ LDMOS DRIVER IC
U102	5185765B26	IC PWR CTRL IN MOS20

ITEM	MOTOROLA PART NUMBER	DESCRIPTION
U103	5115022H01	IC TEMPERATURE SENSOR
U201	5116411H01	IC,OP AMP
U202	5116245H01	CC LVFRACN
U220	5185941F40	IC, 12 BIT DAC
U250	5105750U56	IC PKG DIE VCO BUFFER
U302	2113743L41	CAP CHIP 10000 PF 10 X7R
U304	4809788E21	DIODE, ZENER, SOD-323, SMD, W18 COMPLIANT
U401	5185963A85	IC-ABACUS III-LP
U500	5188493T01	IC,VREG/SWG,LP2989,SM,IC MINI SO-8 HI PRCN REG 5V
U501	5185941F35	IC, VREG, NOPB
U502	5185941F35	IC, VREG, NOPB
U601	5185941F22	IC,OPAMP,SGL,OPA237,SOT23, NOPB
U602	5185941F22	IC,OPAMP,SGL,OPA237,SOT23, NOPB
U701	5185143E77	IC, MAKO ASIC, CMOS PWR MGMT
U702	5185941F22	IC,OPAMP,SGL,OPA237,SOT23, NOPB
U705	5114000B39	IC,BFR,1PER PKG,SM,SOT-353,PB-FREE
U712	5188691V01	IC,MUX/ DEMUX,NC7SB3157P6X,SM,SC 70-6,1PER PKG,BUS,PB FREE
U713	5115453H01	RAIL TO RAIL OUTPUT, 8 PIN BGA
U714	5115453H01	RAIL TO RAIL OUTPUT, 8 PIN BGA
U800	5185941F04	IC, PATRIOT BRAVO, 1.2.2,256BGA, PB-FREE
U801	5114000B39	IC,BFR,1PER PKG,SM,SOT-353,PB-FREE
U802	5114000B39	IC,BFR,1PER PKG,SM,SOT-353,PB-FREE
U803	5185956E69	IC,DRAM,64MB,60NS,IC 1.8V 64
U804	5185941F03	IC,SRAM,8M,512KX16,70NS,SM ,FBGA48,1.95V
VR500	4809788E21	DIODE, ZENER, SOD-323, SMD, W18 COMPLIANT

ITEM	MOTOROLA PART NUMBER	DESCRIPTION
VR501	4813977M19	DIODE,ZEN,MBZ5240,SM,SOT-23,10V,10MA,.225W,ZEN,PB-FREE
VR502	4809788E21	DIODE, ZENER, SOD-323, SMD, W18 COMPLIANT
VR503	4809788E21	DIODE, ZENER, SOD-323, SMD, W18 COMPLIANT
VR504	4809788E21	DIODE, ZENER, SOD-323, SMD, W18 COMPLIANT
VR505	4809788E21	DIODE, ZENER, SOD-323, SMD, W18 COMPLIANT
VR506	4809788E21	DIODE, ZENER, SOD-323, SMD, W18 COMPLIANT
VR508	4813977A43	PB-FREE, NOTCOMPLETELYENRICHED
VR509	4813977A43	PB-FREE, NOTCOMPLETELYENRICHED
VR510	4813977A43	PB-FREE, NOTCOMPLETELYENRICHED
VR511	4813977A43	PB-FREE, NOTCOMPLETELYENRICHED
VR512	4813977A43	PB-FREE, NOTCOMPLETELYENRICHED
VR513	4813977A43	PB-FREE, NOTCOMPLETELYENRICHED
VR650	4813979P12	DIODE ARRAY,TRANSIENT PROTECTION,SM,SOT-457,12V,.225W,ZEN,4,PB
VR651	4813977A43	PB-FREE, NOTCOMPLETELYENRICHED
VR652	4813977A43	PB-FREE, NOTCOMPLETELYENRICHED
VR657	4809788E21	DIODE, ZENER, SOD-323, SMD, W18 COMPLIANT
VR658	4813977C23	DIODE 13V 'H3' MMSZ5243BT1
VR659	4813979P10	DIODE ARRAY,TRANSIENT PROTECTION,SM,SOT-457,5.6V,.225W,ZEN,4,P
VR662	4813979P10	DIODE ARRAY,TRANSIENT PROTECTION,SM,SOT-457,5.6V,.225W,ZEN,4,P
VR663	4813977M18	DIODE,ZEN,SOT-23,9.1V,.225W,PB

ITEM	MOTOROLA PART NUMBER	DESCRIPTION
VR678	4866544A01	DIODE ARRAY,ZEN,SR05.TCT,SM,5V,5, LOW CAPACITANCE TVS DIO
VR701	4813977M11	DIODE,ZEN,MBZ5232,SM,SOT-23,5.6V,10MA,.225W,ZEN,PB-FREE
Y200	4802245J68	OSC, REF 16.8 MHZ 1.5 PPM
Y701	4809995L05	XTAL QUARTZ 32.768KHZ CC4V-T1
Y702	4864005H01	RESONATOR, CRYSTAL 24.576 MHZ

Notes:

- For optimum performance, order replacement diodes, transistors, and circuit modules by Motorola part number only.
- When ordering crystals, specify carrier frequency, crystal frequency, crystal type number, and Motorola part number.
- Part value notations:
 $p=10^{-12}$
 $n=10^{-9}$
 $\mu=10^{-6}$
 $m=10^{-3}$
 $k=10^3$
 $M=10^6$
- ITEM refers to the component reference designator. SIDE refers to the location of the component on the board; S1=Side 1, S2=Side 2.
- The PMLD4303A RF Board uses a 6-layer printed circuit board.

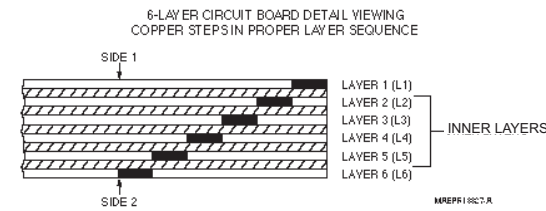

Chapter 9.4 700/800 MHz Schematics, Board Overlays, and Parts Lists

9.4.1 Introduction

This chapter contains the schematics, board layouts, and parts lists for the XTS 2500/2500I/2250/1500 radios. Use them in conjunction with the theory of operation and the troubleshooting procedures, charts, and waveforms to isolate a problem to the component level.

Table 9.4-1. 700/800 Schematics, Board Overlays and Parts Lists

Schematic/Board Layout	Page No.
PMLF4040A/ PMLF4040B (8416095H01-A) Top Level Schematic	9.4-2
PMLF4040A/ PMLF4040B Controller Interface Schematic	9.4-3
PMLF4040A/ PMLF4040B Interface and Accessories Schematic	9.4-4
PMLF4040A/ PMLF4040B Side Connector Schematic	9.4-5
PMLF4040A/ PMLF4040B Controller Schematic	9.4-6
PMLF4040A/ PMLF4040B Patriot Bravo (U800) Schematic	9.4-7
PMLF4040A/ PMLF4040B MAKO DC and Audio Schematic - Sheet 1 of 2	9.4-8
PMLF4040A/ PMLF4040B MAKO DC and Audio Schematic - Sheet 2 of 2	9.4-9
PMLF4040A/ PMLF4040B Memory Schematic	9.4-10
PMLF4040A/ PMLF4040B Frequency Generation Unit (FGU) Schematic - Sheet 1 of 3	9.4-11
PMLF4040A/ PMLF4040B Frequency Generation Unit (FGU) Schematic - Sheet 2 of 3	9.4-12
PMLF4040A/ PMLF4040B Frequency Generation Unit (FGU) Schematic - Sheet 3 of 3	9.4-13
PMLF4040A/ PMLF4040B Receiver Schematic - Sheet 1 of 2	9.4-14
PMLF4040A/ PMLF4040B Receiver Schematic - Sheet 2 of 2	9.4-15
PMLF4040A/ PMLF4040B Transmitter Schematic	9.4-16
PMLF4040A/ PMLF4040B RF Schematic	9.4-17
PMLF4040A/ PMLF4040B (8416095H01-A) Main Circuit Board Component Location Detail - Side 1	9.4-18
PMLF4040A/ PMLF4040B (8416095H01-A) Main Circuit Board Component Location Detail - Side 2	9.4-19
PMLF4040A/ PMLF4040B (8416095H01-A) Main Circuit Board Electrical Parts List	9.4-20

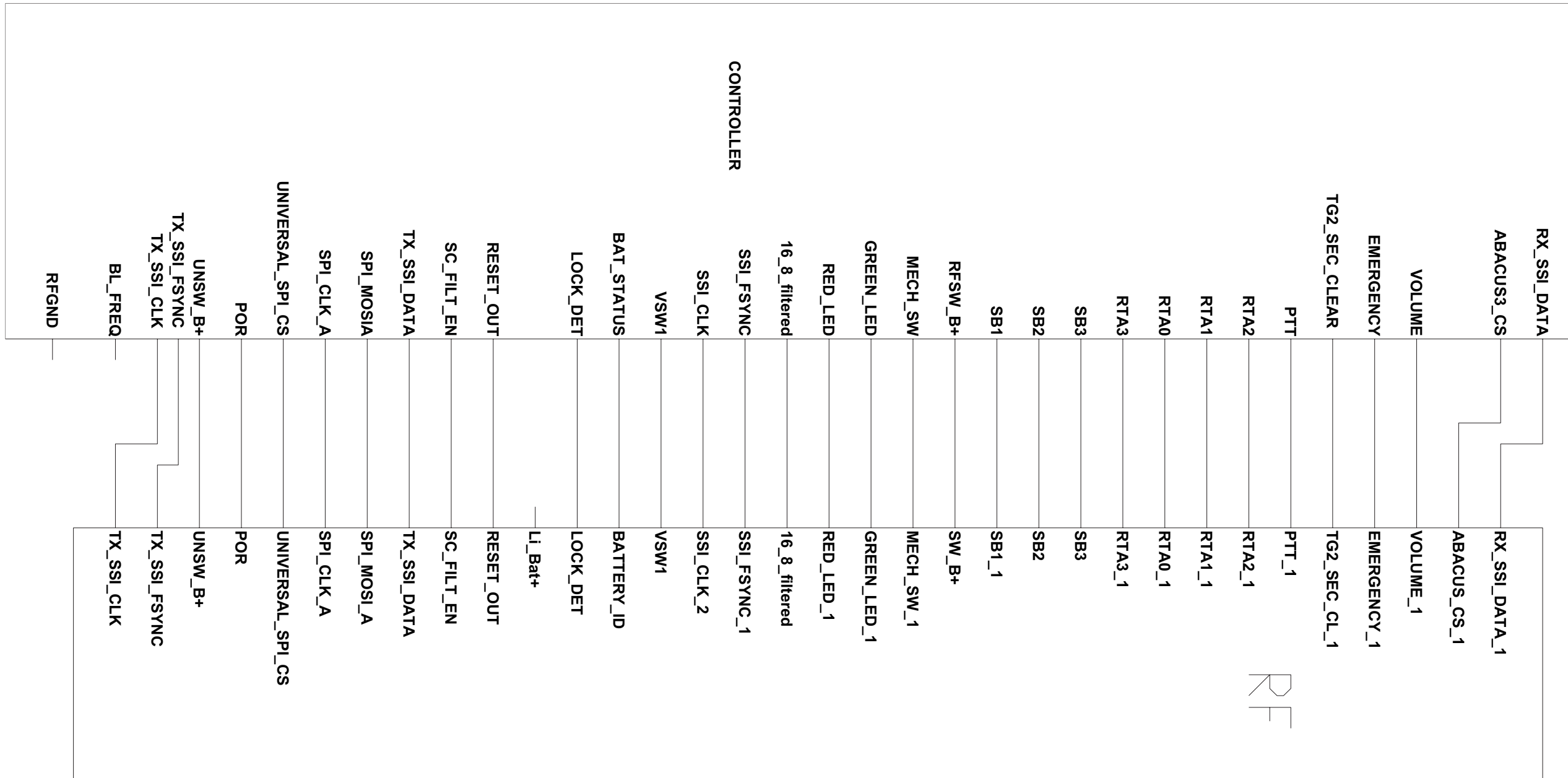

Figure 9.4-1. PMLF4040A/ PMLF4040B (8416095H01-A) Top Level Schematic

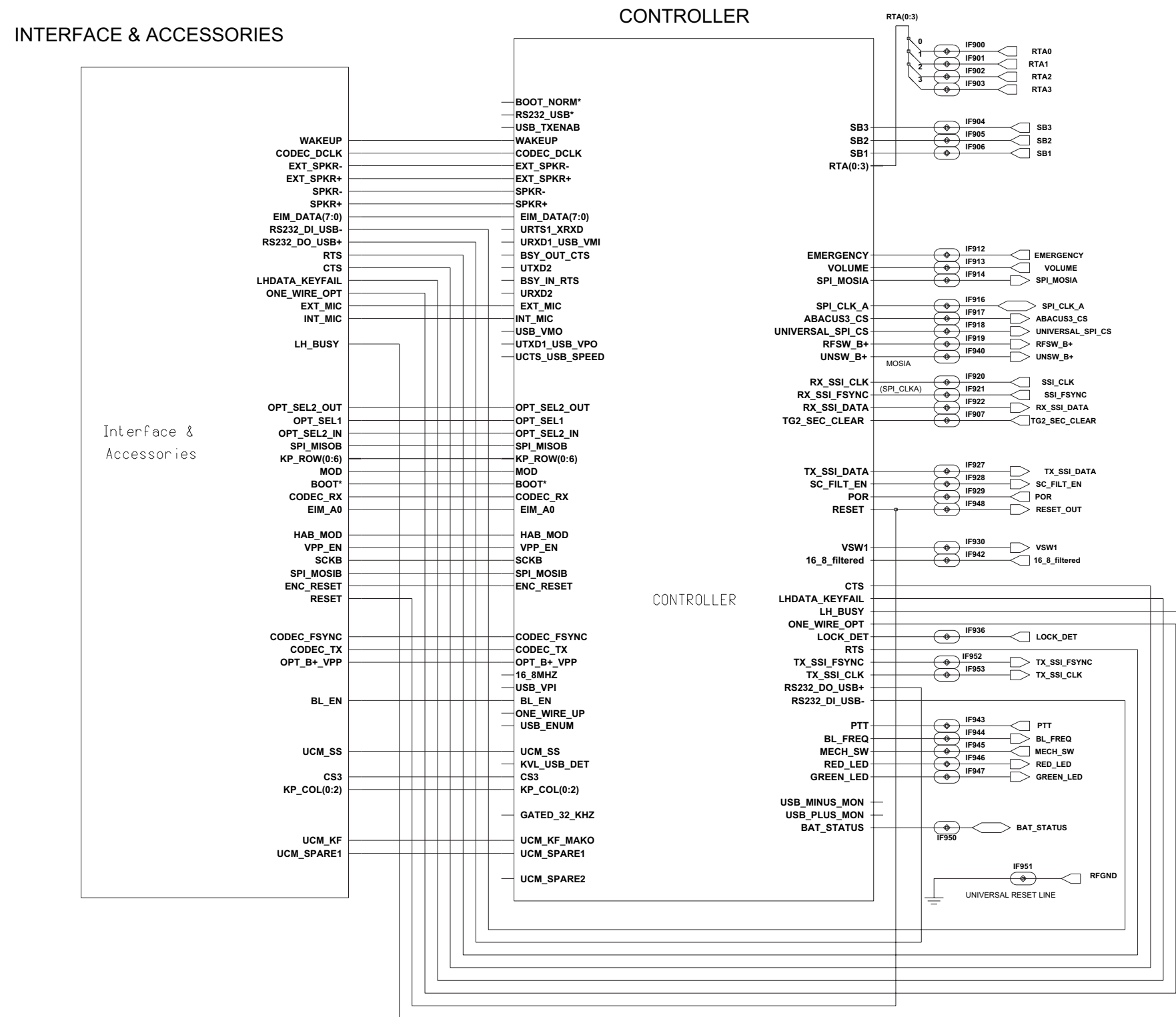

Figure 9.4-2. PMLF4040A/ PMLF4040B Controller Interface Schematic

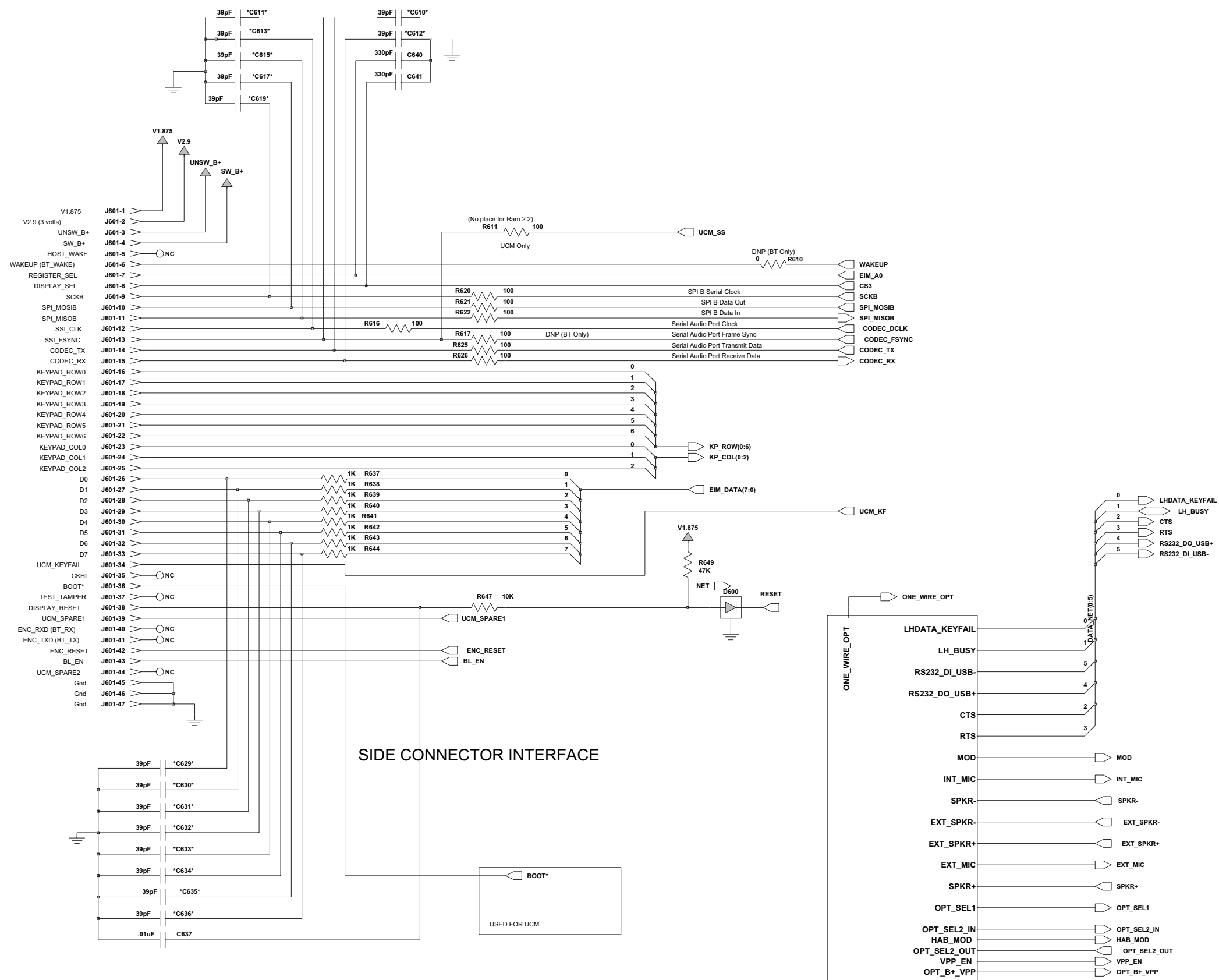

Figure 9.4-1. PMLF4040A/ PMLF4040B Interface and Accessories Schematic

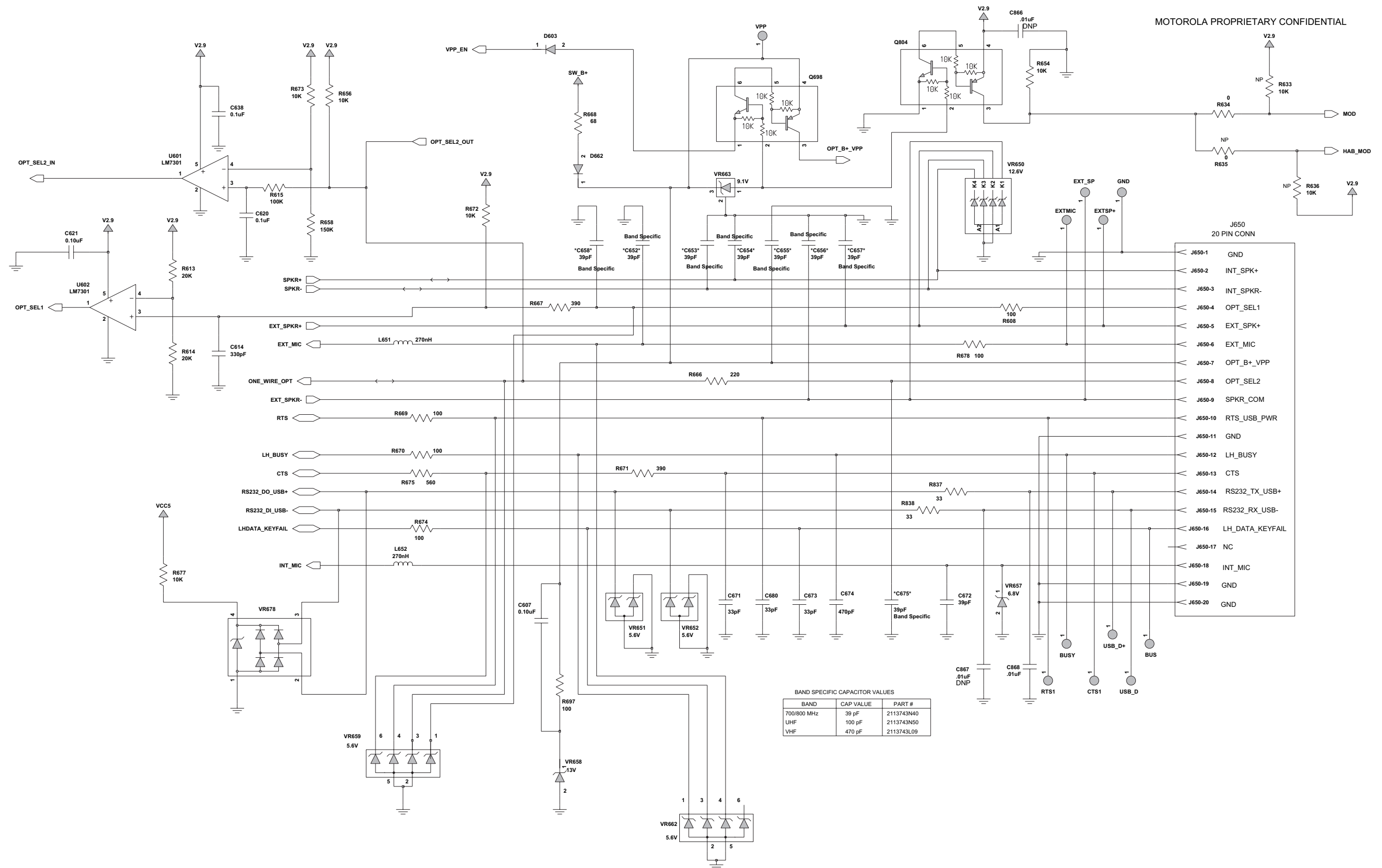

Figure 9.4-3. PMLF4040A/ PMLF4040B Side Connector Schematic

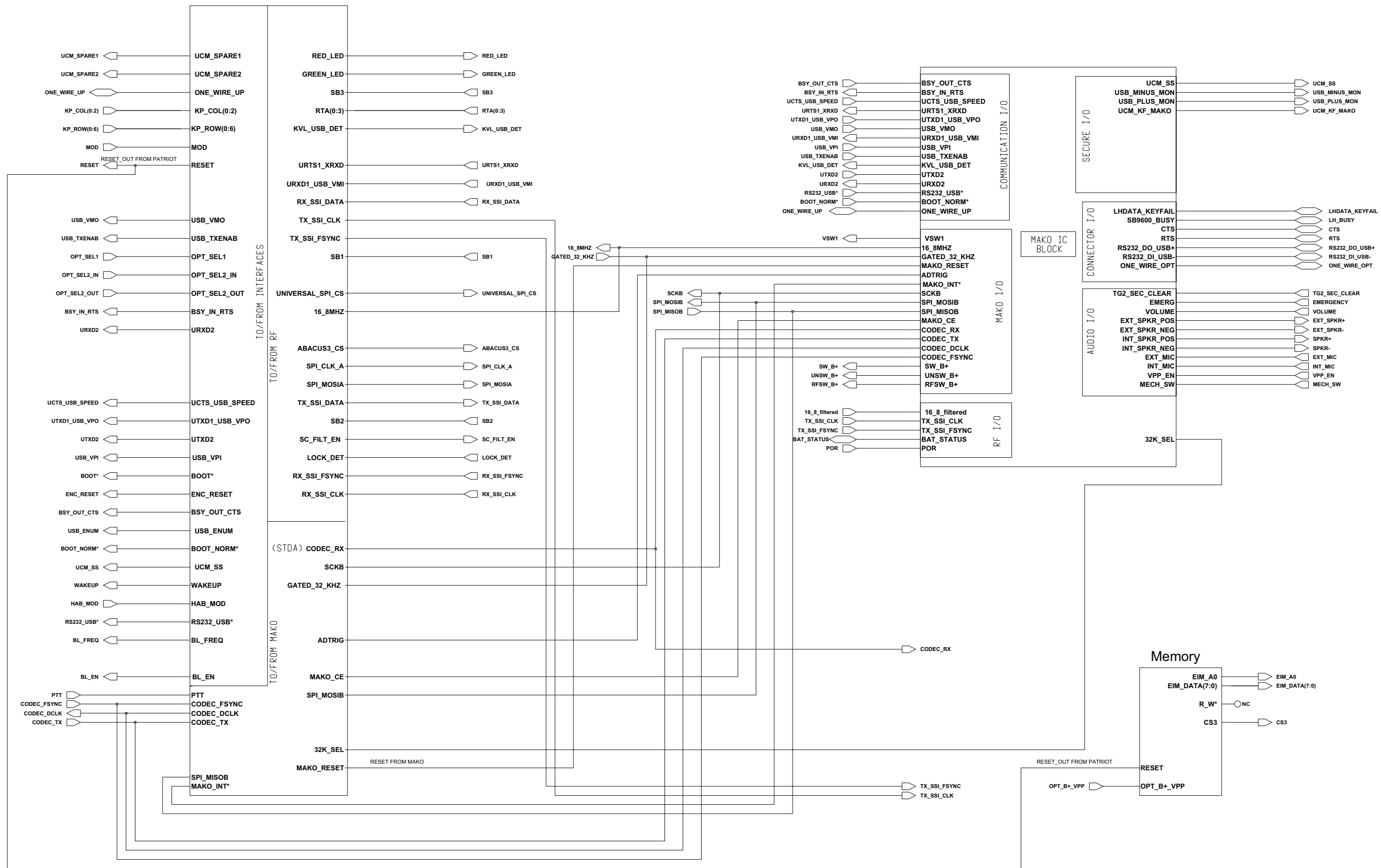

Figure 9.4-4. PMLF4040A/ PMLF4040B Controller Schematic

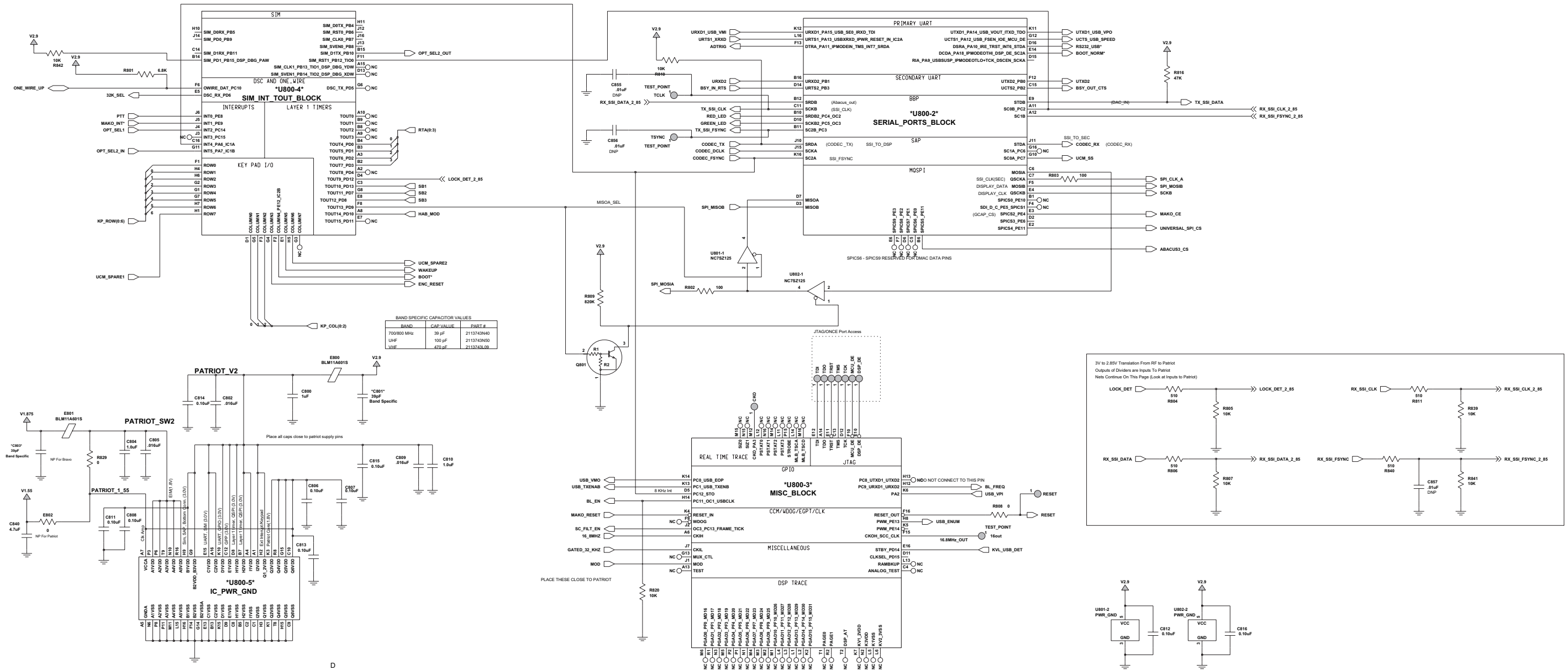

Figure 9.4-5. PMLF4040A/ PMLF4040B Patriot Bravo (U800) Schematic

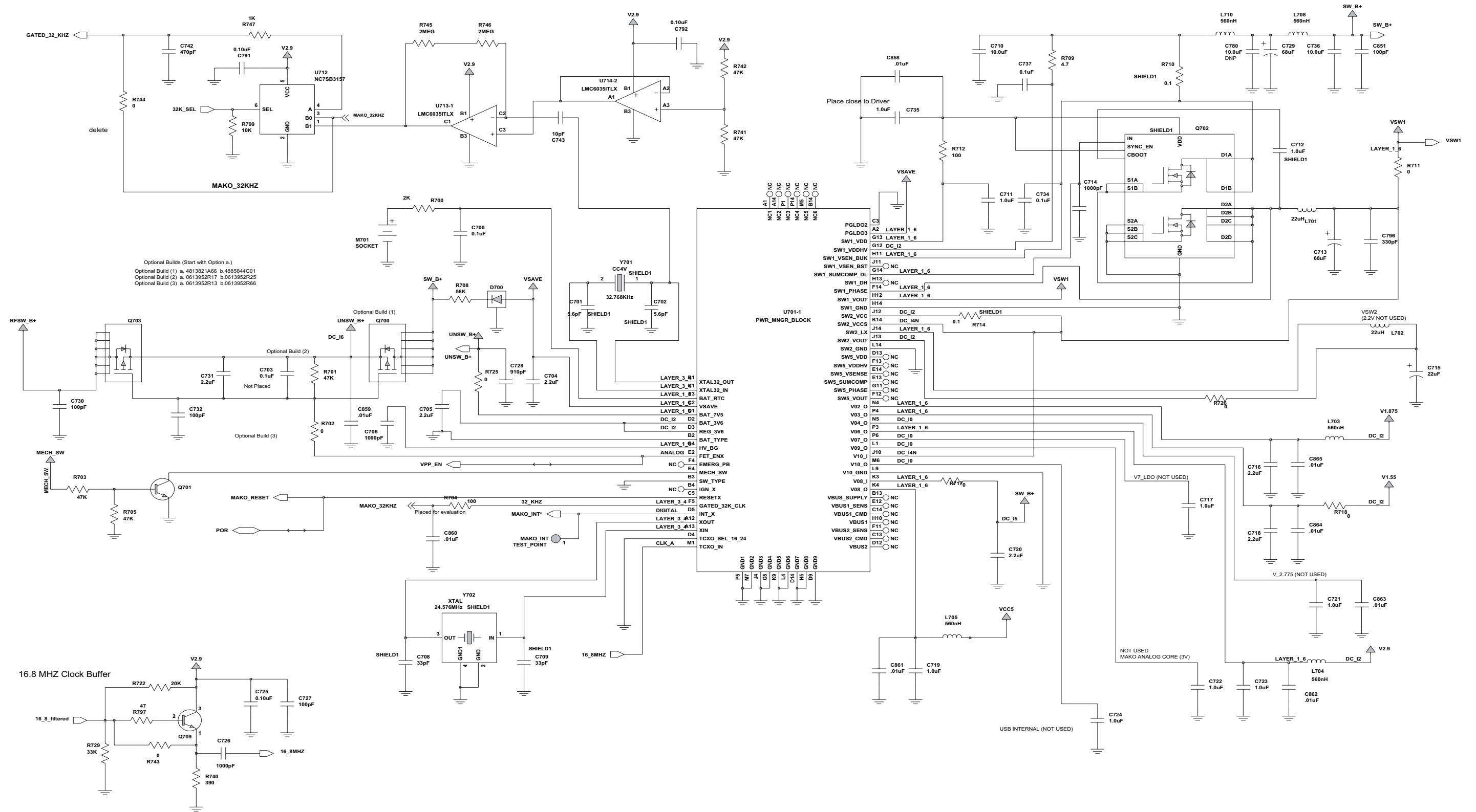

Figure 9.4-6. PMLF4040A/ PMLF4040B MAKO DC and Audio Schematic - Sheet 1 of 2

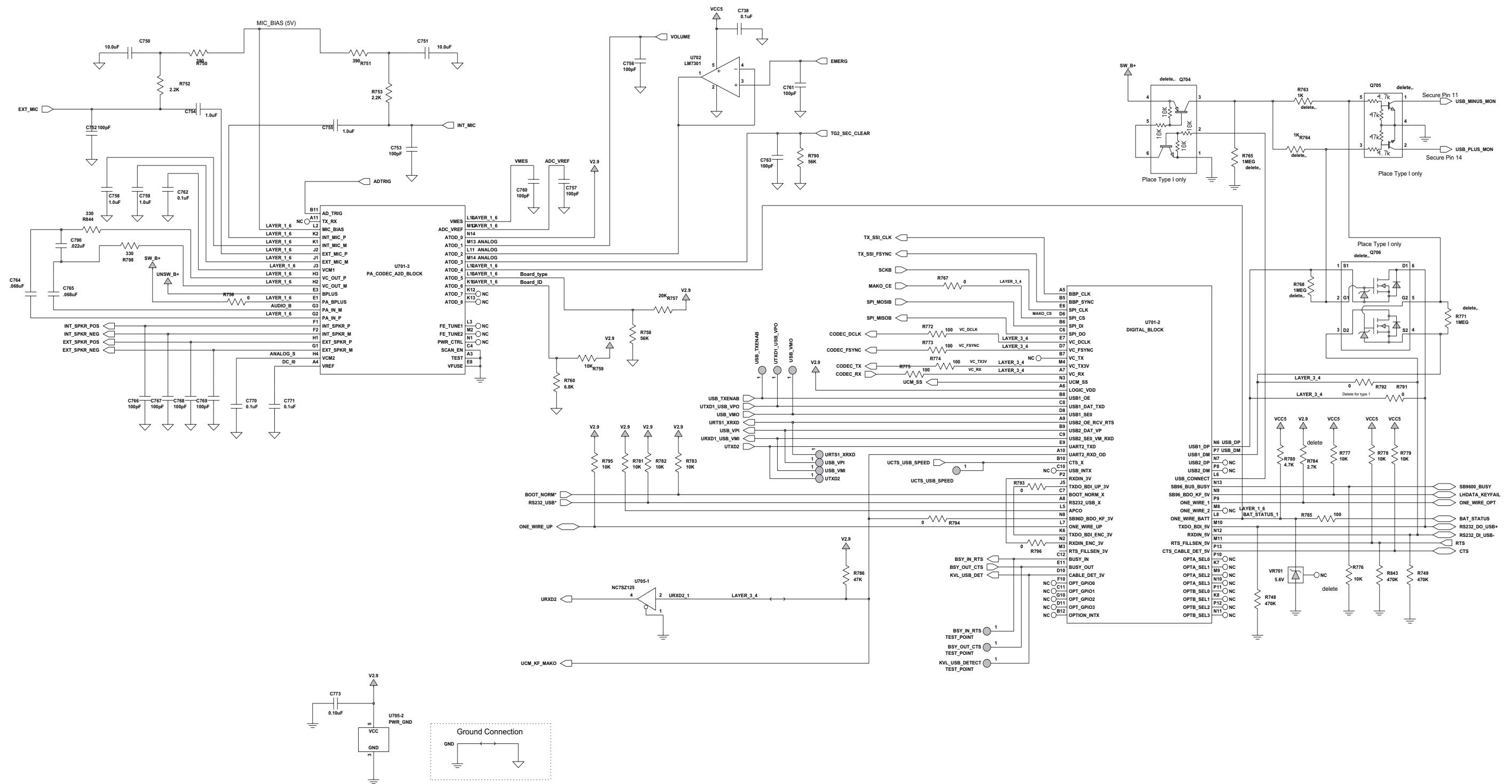

Figure 9.4-7. PMLF4040A/ PMLF4040B MAKO DC and Audio Schematic - Sheet 2 of 2

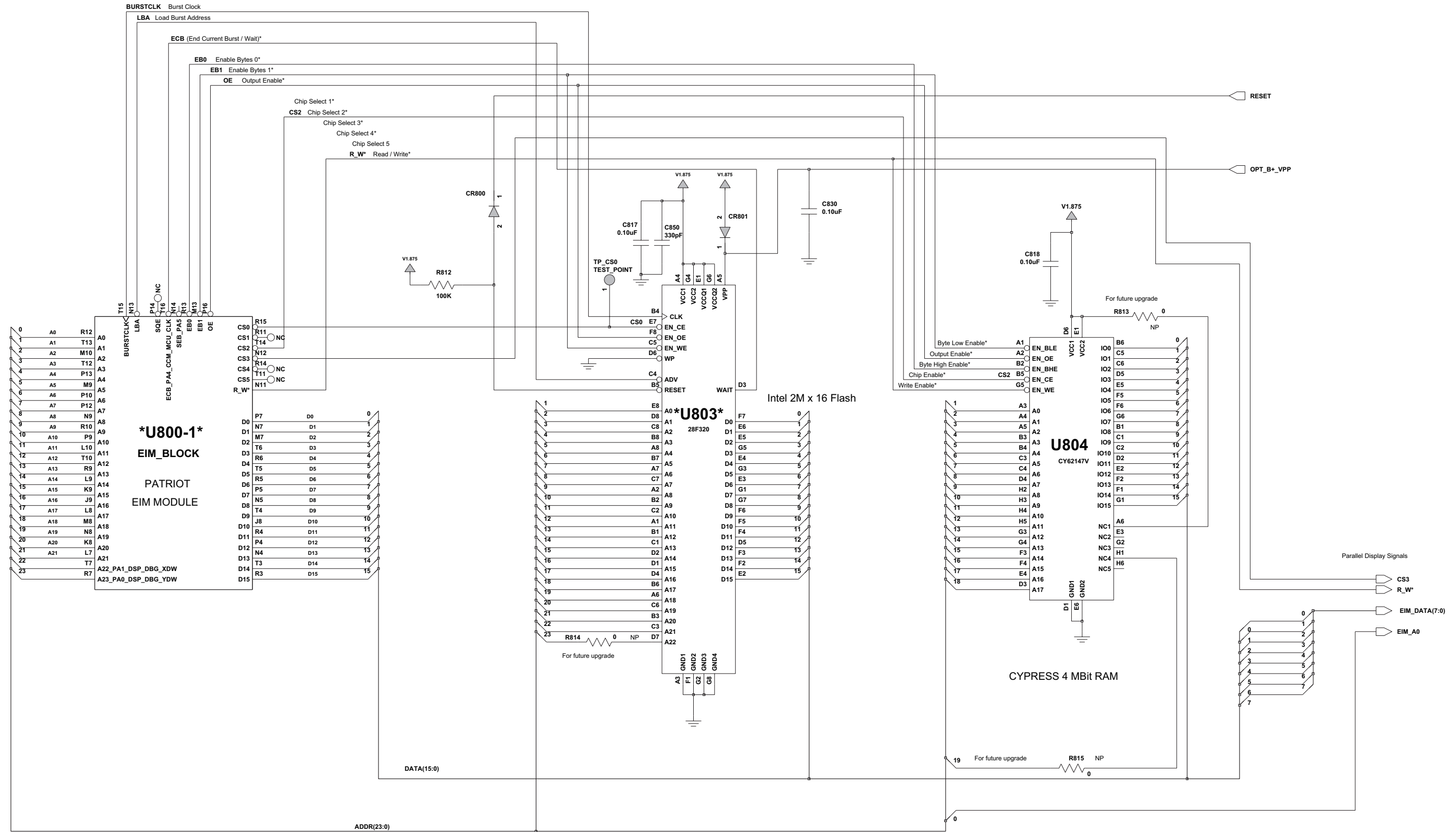

Figure 9.4-8. PMLF4040A/ PMLF4040B Memory Schematic

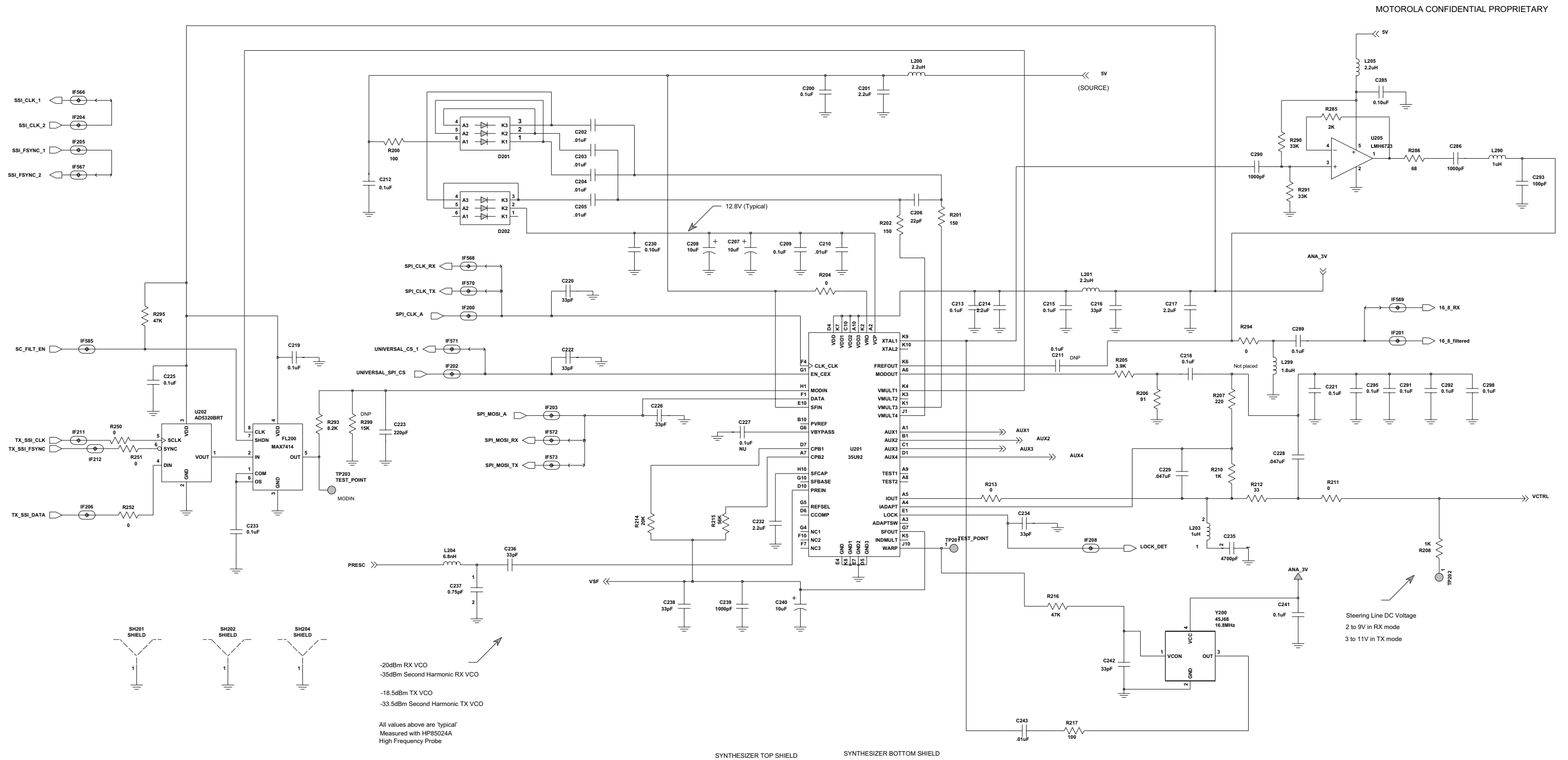

Figure 9.4-9. PMLF4040A/ PMLF4040B Frequency Generation Unit (FGU) Schematic - Sheet 1 of 3

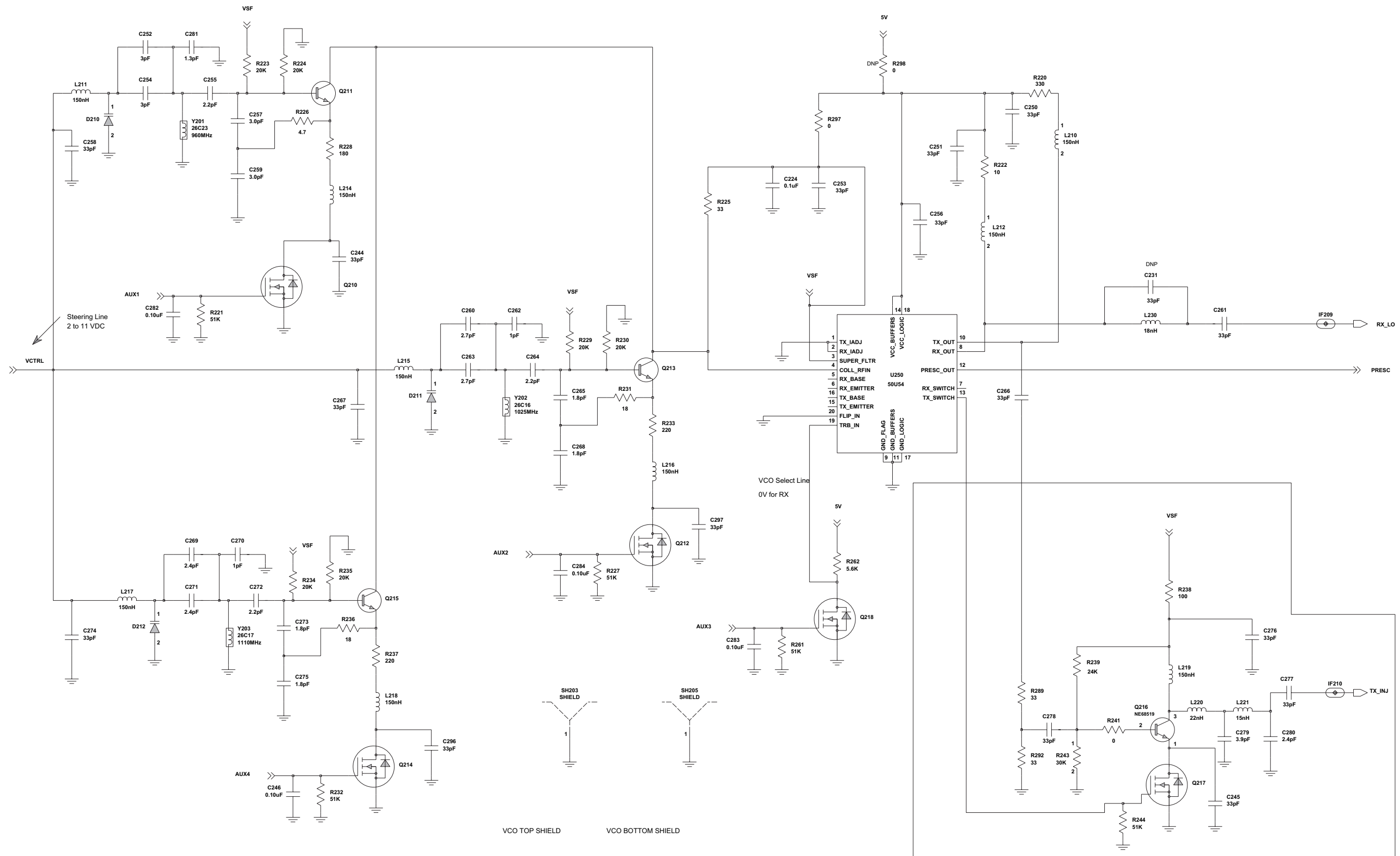

Figure 9.4-1. PMLF4040A/ PMLF4040B Frequency Generation Unit (FGU) Schematic - Sheet 2 of 3

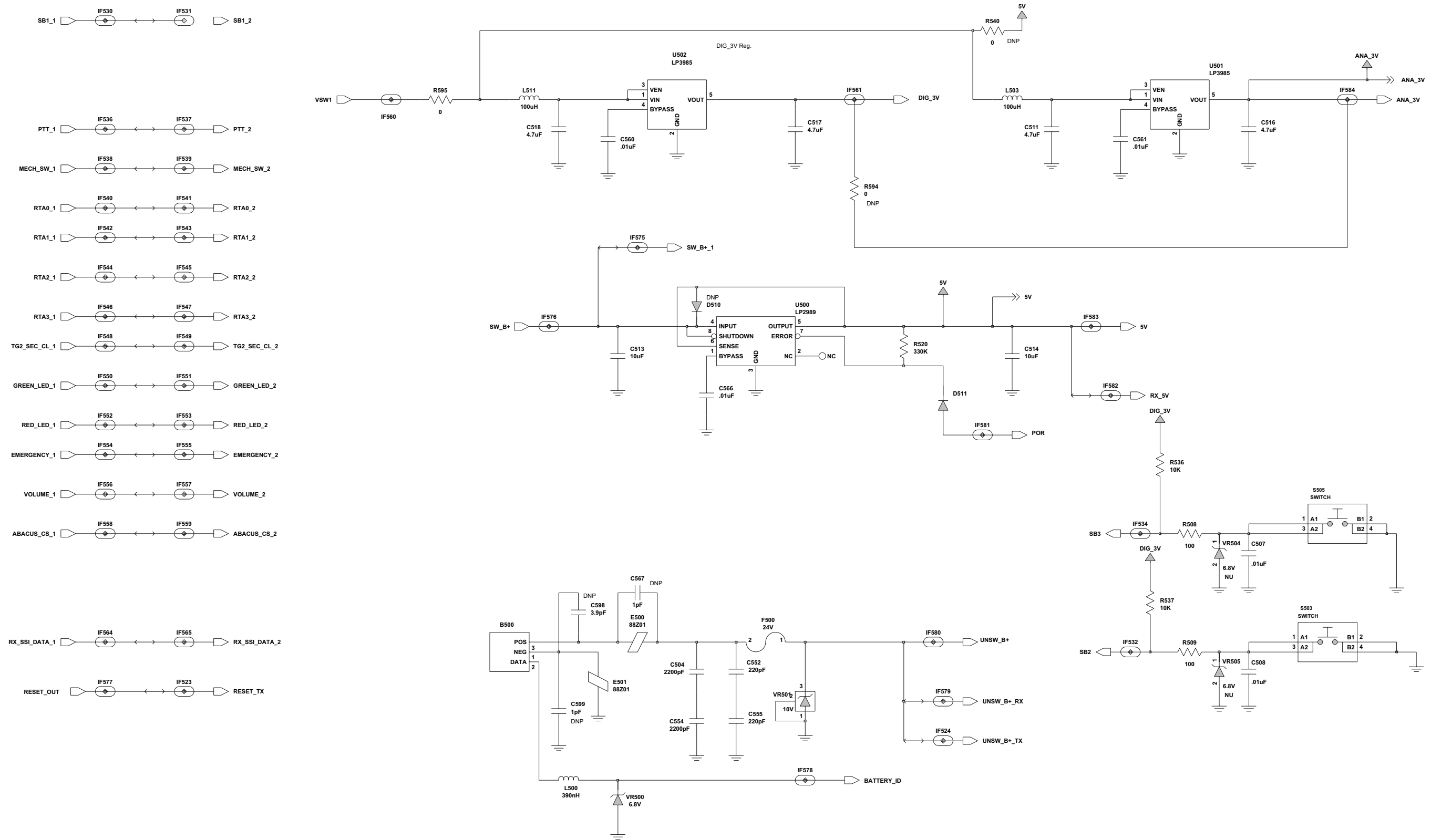

Figure 9.4-10. PMLF4040A/ PMLF4040B Frequency Generation Unit (FGU) Schematic - Sheet 3 of 3

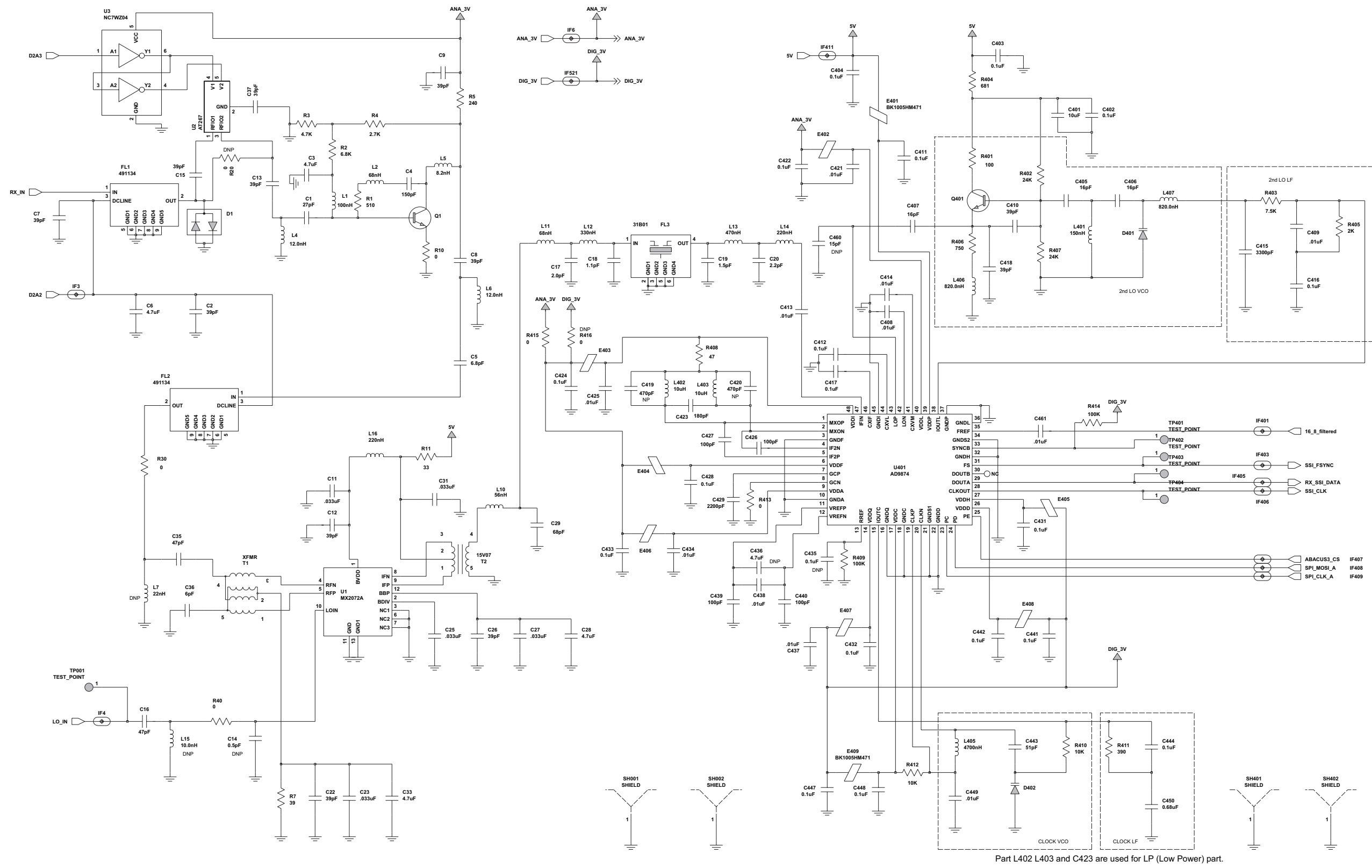

Figure 9.4-11. PMLF4040A/ PMLF4040B Receiver Schematic - Sheet 1 of 2

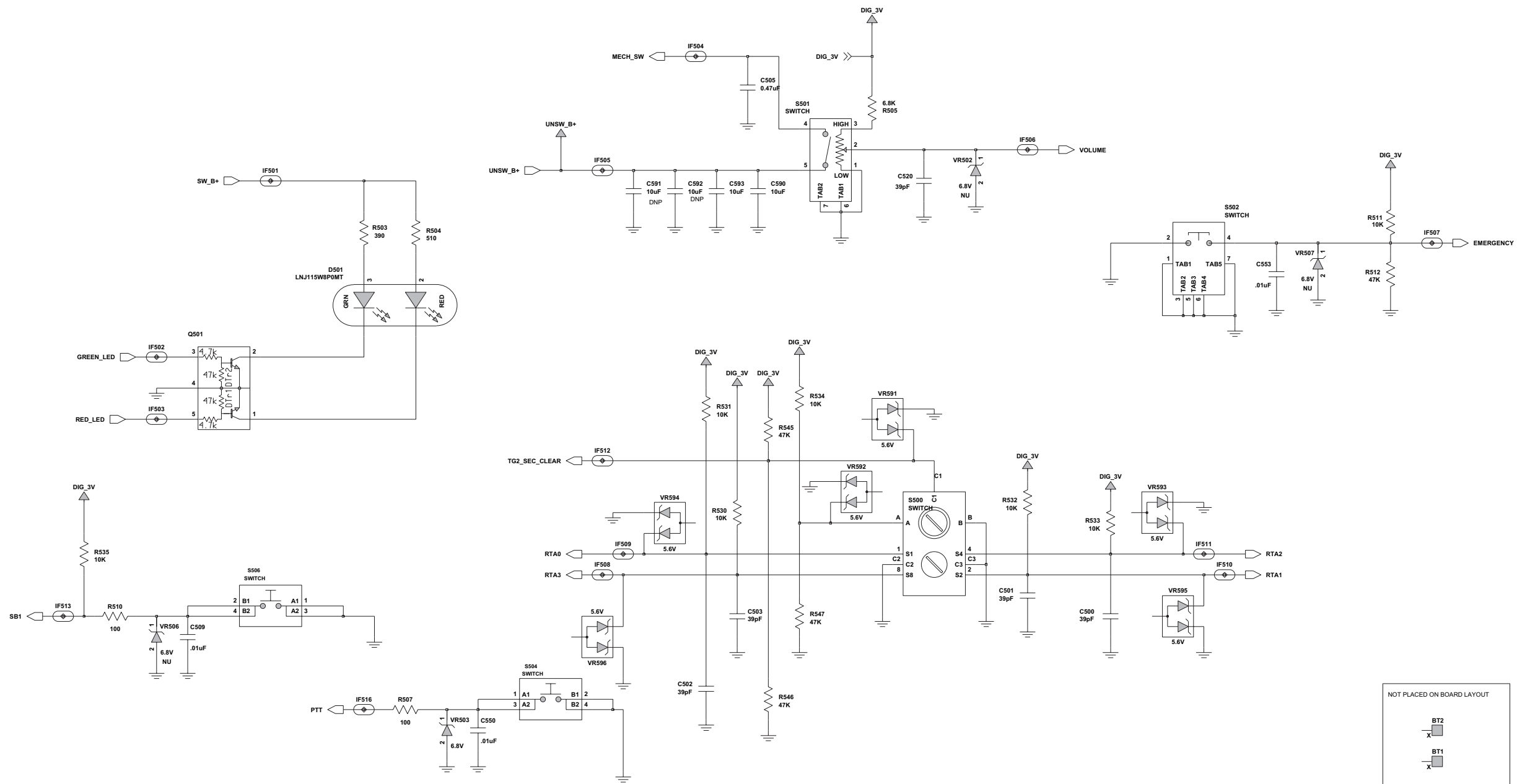

Figure 9.4-12. PMLF4040A/ PMLF4040B Receiver Schematic - Sheet 2 of 2

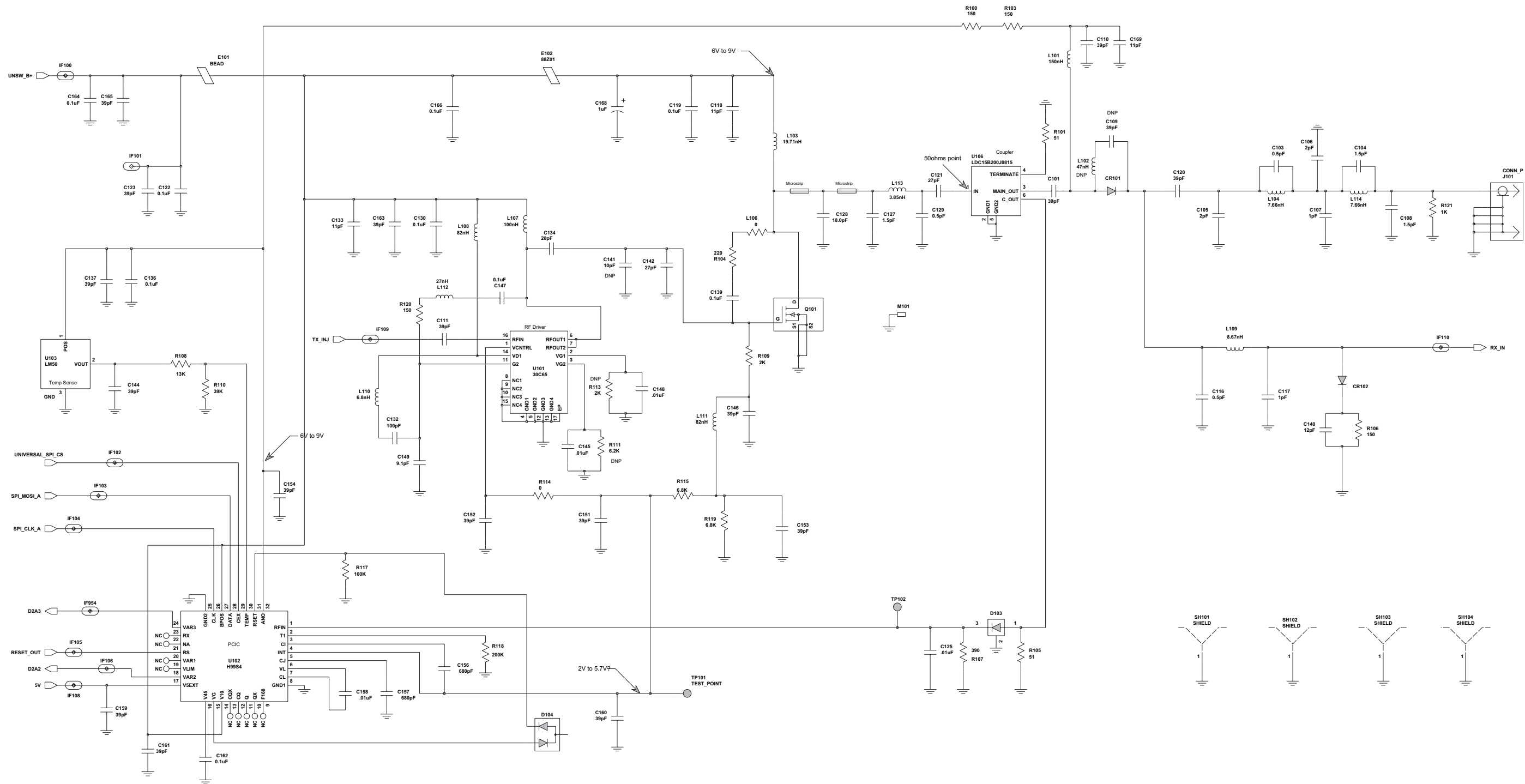

Figure 9.4-13. PMLF4040A/ PMLF4040B Transmitter Schematic

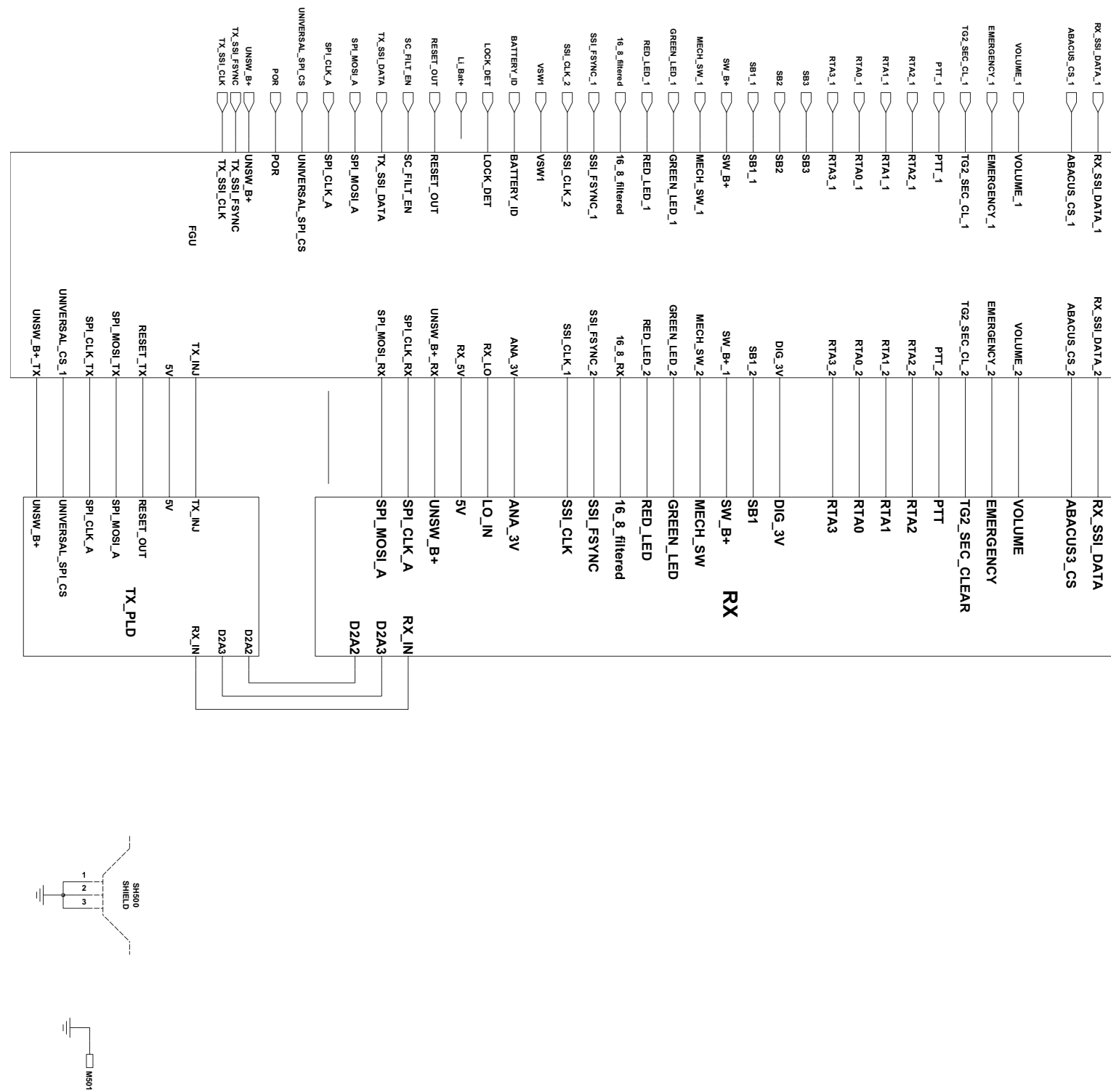

Figure 9.4-14. PMLF4040A/ PMLF4040B RF Schematic

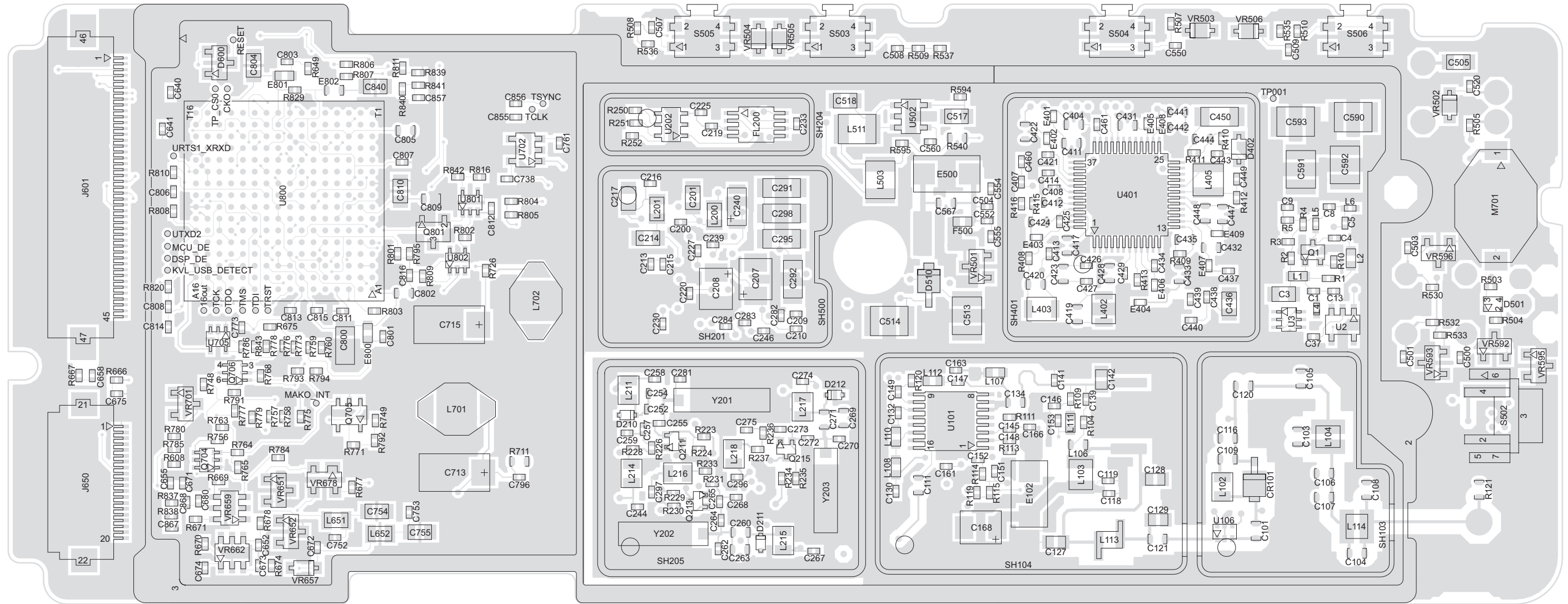

Figure 9.4-15. PMLF4040A/ PMLF4040B (8416095H01-A) Main Circuit Board Component Location Detail - Side 1

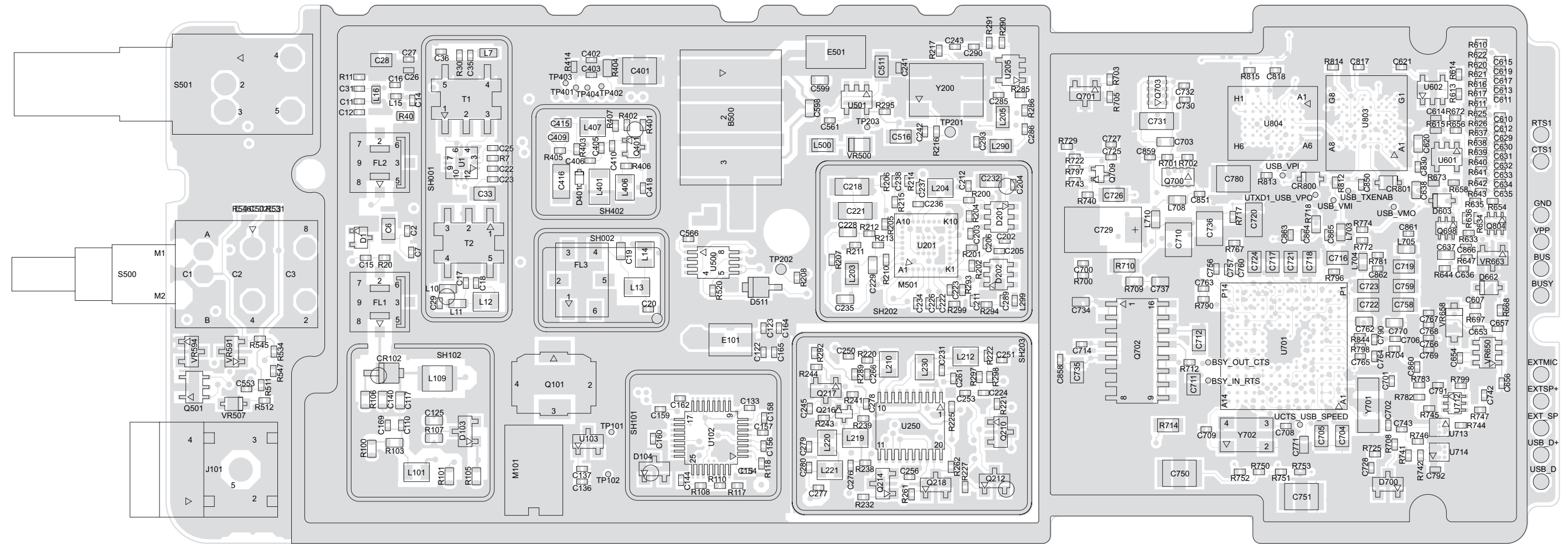

Figure 9.4-16. PMLF4040A/ PMLF4040B (8416095H01-A) Main Circuit Board Component Location Detail - Side 2

PMLF4040A/ PMLF4040B (8416095H01-A) Main
Circuit Board
Electrical Parts List

ITEM	MOTOROLA PART NUMBER	DESCRIPTION
B500	0986237A02	CONNECTOR (CONTACT BATTERY)
C1	2113944A30	27PF
C2	2113944A32	39PF
C3	NOTPLACED	
C4	2113944A42	150PF
C5	2113944A21	6.8PF
C6	2113946F03	4.7UF
C7	2113944A32	39PF
C8	2113944A32	39PF
C9	2113944A32	39.0PF
C11	2113945B05	0.033UF
C12	2113944A32	39PF
C13	2113944A32	39PF
C14	NOTPLACED	
C15	2113944A32	39PF
C16	2113944A33	47PF
C17	2113944A08	2PF
C18	2113944A01	1.1PF
C19	2113944C67	1.5PF
C20	2113944A09	2.2PF
C22	2113944A32	39PF
C23	2113945B05	0.033UF
C25	2113945B05	0.033UF
C26	2113944A32	39PF
C27	2113945B05	0.033UF

ITEM	MOTOROLA PART NUMBER	DESCRIPTION
C28	2113946F03	4.7UF
C29	2113944A36	68PF
C31	2113945B05	0.033UF
C33	2113946F03	4.7UF
C35	2113944A33	47PF
C36	2113944A70	6PF
C37	2113944A32	39PF
C101	2113944C37	39PF
C103	2113944C61	0.5PF
C104	2113944C67	1PF
C105	2113944C13	2PF
C106	2113944C13	2PF
C107	2113944C63	1PF
C108	2113944C67	1PF
C109	NOTPLACED	
C110	2113944A32	39PF
C111	2113944C37	39PF
C116	2113944C61	0.5PF
C117	2113944C63	1PF
C118	2113944A77	11PF
C119	2113946K02	0.10UF
C120	2113944C37	39PF
C121	2113944M28	27PF
C122	2113946K02	0.10UF
C123	2113944A32	39PF
C125	2113945L49	0.01UF
C127	2103689A32	1.5PF
C128	2103689A08	18PF

ITEM	MOTOROLA PART NUMBER	DESCRIPTION
C129	2116636H05	0.5PF
C130	2113946K02	0.10UF
C132	2113944A40	100PF
C133	2113944A77	11PF
C134	2113944M25	20PF
C136	2113946K02	0.10UF
C137	2113944A32	39PF
C139	2113946K02	0.10UF
C140	2113944C31	12PF
C141	NOTPLACED	
C142	2116069H01	27PF
C144	2113944A32	39PF
C145	2113945B02	10000PF
C146	2113944A32	39PF
C147	2113946K02	0.10UF
C148	2113945B02	10,000PF
C149	2113944A24	9.1PF
C151	2113944A32	39PF
C152	2113944A32	39PF
C153	2113944A32	39PF
C154	2113944A32	39PF
C156	2113945A07	680PF
C157	2113945A07	680PF
C158	2113945B02	10,000PF
C159	2113944A32	39PF
C160	2113944A32	39PF
C161	2113944A32	39PF
C162	2113946K02	0.10UF

ITEM	MOTOROLA PART NUMBER	DESCRIPTION
C163	2113944A32	39PF
C164	2113946K02	0.10UF
C165	2113944A32	39PF
C166	2113946K02	0.10UF
C168	2313960C26	1.0 UF
C169	2113944A77	11PF
C200	2113946K02	0.10UF
C201	2113946N03	2.2UF
C202	2113945B02	10000PF
C203	2113945B02	10000PF
C204	2113945B02	10000PF
C205	2113945B02	10000PF
C206	2113944A31	33PF
C207	2313960D07	10UF
C208	2313960D07	10UF
C209	2113946K02	0.10UF
C210	2113945B02	10000PF
C211	NOTPLACED	
C212	2113946K02	0.10UF
C213	2113946K02	0.10UF
C214	2113946N03	2.2UF
C215	2113946K02	0.10UF
C216	2113944A31	33PF
C217	2113946N03	2.2UF
C218	2185419D06	0.1UF
C219	2113946K02	0.1UF
C220	2113944A31	33PF
C221	2185419D06	0.1UF

ITEM	MOTOROLA PART NUMBER	DESCRIPTION	ITEM	MOTOROLA PART NUMBER	DESCRIPTION	ITEM	MOTOROLA PART NUMBER	DESCRIPTION	ITEM	MOTOROLA PART NUMBER	DESCRIPTION
C222	2113944A31	33PF	C253	2113944A31	33PF	C281	2188881Y09	1.3PF	C414	2113945B02	10000PF
C223	2113945A01	220PF	C254	2113944M05	3PF	C282	2113946K02	0.1UF	C415	2113945L37	3300PF
C224	2113946K02	0.1UF	C255	2113944V11	2.2PF	C283	2113946K02	0.1UF	C416	2109720D14	0.1UF
C225	2113946K02	0.1UF	C256	2113944A31	33PF	C284	2113946K02	0.1UF	C417	2113945C31	0.1UF
C226	2113944A31	33PF	C257	2188881Y17	3PF	C285	2113946K02	0.1UF	C418	2113944A32	39PF
C227	2113946K02	0.1UF	C258	2113944A31	33PF	C286	2113945A09	1000PF	C419	NOTPLACED	
C228	2113945C27	0.047UF	C259	2188881Y17	3PF	C289	2113946K02	0.1UF	C420	NOTPLACED	
C229	2113945C27	0.047UF	C260	2113944M04	2.7PF	C290	2113945A09	1000PF	C421	2113945B02	10000PF
C230	2113946K02	0.1UF	C261	2113944A31	33PF	C291	2185419D06	0.1UF	C422	2113945C31	0.1UF
C231	NOTPLACED		C262	2113944V03	1PF	C292	2185419D06	0.1UF	C423	2113944C01	180PF
C232	2113946N03	2.2UF	C263	2113944M04	2.7PF	C293	2113944A40	100PF	C424	2113945C31	0.1UF
C233	2113946K02	0.1UF	C264	2113944V11	2.2PF	C295	2185419D06	0.1UF	C425	2113945B02	10000PF
C234	2113944A31	33PF	C265	2188881Y12	1.8PF	C296	2113944A31	33PF	C426	2113944A40	100PF
C235	2113945L41	4700PF	C266	2113944A31	33PF	C297	2113944A31	33PF	C427	2113944A40	100PF
C236	2113944A31	33PF	C267	2113944A31	33PF	C298	2185419D06	0.1UF	C428	2113945C31	0.1UF
C237	2113944A62	0.75PF	C268	2188881Y12	1.8PF	C401	2113955E37	10UF	C429	2113945A11	2200PF
C238	2113944A31	33PF	C269	2113944M03	2.4PF	C402	2113946K02	0.1UF	C431	2113945C31	0.1UF
C239	2113945A09	1000PF	C270	2113944V03	1PF	C403	2113946K02	0.1UF	C432	2113945C31	0.1UF
C240	2313960B57	10UF	C271	2113944M03	2.4PF	C404	2113945C31	0.1UF	C433	2113945C31	0.1UF
C241	2113946K02	0.1UF	C272	2113944V11	2.2PF	C405	2113944A79	16PF	C434	2113945B02	10000PF
C242	2113944A31	33PF	C273	2188881Y12	1.8PF	C406	2113944A79	16PF	C435	NOTPLACED	
C243	2113945B02	10000PF	C274	2113944A31	33PF	C407	2113944A79	16PF	C436	NOTPLACED	
C244	2113944A31	33PF	C275	2188881Y12	1.8PF	C408	2113945B02	10000PF	C437	2113945B02	10000PF
C245	2113944A31	33PF	C276	2113944A31	33PF	C409	2113945L49	0.01UF	C438	2113945B02	10000PF
C246	2113946K02	0.1UF	C277	2113944A31	33PF	C410	2113944A32	39PF	C439	2113944A40	100PF
C250	2113944A31	33PF	C278	2113944A31	33PF	C411	2113945C31	0.1UF	C440	2113944A40	100PF
C251	2113944A31	33PF	C279	2113944A15	3.9PF	C412	2113945C31	0.1UF	C441	2113945C31	0.1UF
C252	2113944M05	3PF	C280	2113944A10	2.4PF	C413	2113945B02	10000PF	C442	2113945C31	0.1UF

ITEM	MOTOROLA PART NUMBER	DESCRIPTION	ITEM	MOTOROLA PART NUMBER	DESCRIPTION	ITEM	MOTOROLA PART NUMBER	DESCRIPTION	ITEM	MOTOROLA PART NUMBER	DESCRIPTION
C443	2113944A85	51PF	C555	2113945A01	220PF	C635	2113944A32	39PF	C710	2113946J03	10 UF
C444	2113945C31	0.1UF	C560	2113945B02	10000PF	C636	2113944A32	39PF	C711	2113946E02	1 UF
C447	2113945C31	0.1UF	C561	2113945B02	10000PF	C637	2113945L49	0.01UF	C712	2113946E02	1 UF
C448	2113945C31	0.1UF	C566	2113945B02	10000PF	C638	2113945C31	0.1UF	C713	2314030F03	22 UF
C449	2113945B02	10000PF	C567	NOTPLACED		C640	NOTPLACED		C714	2113945A09	1000PF
C450	2113946G04	0.68UF	C590	NOTPLACED		C641	NOTPLACED		C715	2314030F03	22 UF
C460	NOTPLACED		C591	NOTPLACED		C652	2113944A32	39PF	C716	2113946F01	2.2 UF
C461	2113945B02	10000PF	C592	NOTPLACED		C653	2113944A32	39PF	C717	2113946E02	1 UF
C500	2113944A32	39PF	C593	2113955E37	10UF	C654	2113944A32	39PF	C718	2113946F01	2.2 UF
C501	2113944A32	39PF	C598	NOTPLACED		C655	2113944A32	39PF	C719	2113946E02	1 UF
C502	2113944A32	39PF	C599	NOTPLACED		C656	2113944A32	39PF	C720	2113946G01	2.2 UF
C503	2113944A32	39PF	C607	2113946K02	0.1UF	C657	2113944A32	39PF	C721	2113946E02	1 UF
C504	2113945A11	2200PF	C610	2113944A32	39PF	C658	2113944A32	39PF	C722	2113946E02	1 UF
C505	2113945G98	0.47UF	C611	2113944A32	39PF	C671	2113944A31	33PF	C723	2113946E02	1 UF
C507	2113945B02	10000PF	C612	2113944A32	39PF	C672	2113944A32	39PF	C724	2113946E02	1 UF
C508	2113945B02	10000PF	C613	2113944A32	39PF	C673	2113944A31	33PF	C725	2113946K02	0.1 UF
C509	2113945B02	10000PF	C614	2113945A03	330PF	C674	2113945A05	470PF	C726	2113944F07	1000PF
C511	2113946F03	4.7UF	C615	2113944A32	39PF	C675	2113944A32	39PF	C727	2113944A40	100PF
C513	2113955E37	10UF	C617	2113944A32	39PF	C680	2113944A31	33PF	C728	2113945A58	910PF
C514	2113955E37	10UF	C619	2113944A32	39PF	C700	2113946B04	0.1 UF	C729	2314030V06	68 UF
C516	2113946F03	4.7UF	C620	2113945C31	0.1UF	C701	2113944A19	5.6PF	C730	2113944A40	100PF
C517	2113946F03	4.7UF	C621	2113946K02	0.1UF	C702	2113944A19	5.6PF	C731	2113946G01	2.2 UF
C518	2113946F03	4.7UF	C629	2113944A32	39PF	C703	NOTPLACED		C732	2113944A40	100PF
C520	2113944A32	39PF	C630	2113944A32	39PF	C704	2113946F01	2.2 UF	C734	2113945C31	0.1 UF
C550	2113945B02	10000PF	C631	2113944A32	39PF	C705	2113946F01	2.2 UF	C735	2113946E02	1 UF
C552	2113945A01	220PF	C632	2113944A32	39PF	C706	2113945A09	1000PF	C736	2113946J03	10 UF
C553	2113945B02	10000PF	C633	2113944A32	39PF	C708	2113944A31	33PF	C737	2113945C31	0.1 UF
C554	2113945A11	2200PF	C634	2113944A32	39PF	C709	2113944A31	33PF	C738	2113946K02	0.1 UF

ITEM	MOTOROLA PART NUMBER	DESCRIPTION	ITEM	MOTOROLA PART NUMBER	DESCRIPTION	ITEM	MOTOROLA PART NUMBER	DESCRIPTION	ITEM	MOTOROLA PART NUMBER	DESCRIPTION
C742	2113945A05	470PF	C792	2113946K02	0.1 UF	C858	2113945B02	10,000PF	D511	4813978M15	DIODE
C743	2113944A25	10PF	C796	2113945A03	330PF	C859	2113945B02	10,000PF	D600	4813978B18	DIODE
C750	2113946J03	10 UF	C800	2113955D31	1 UF	C860	2113945B02	10,000PF	D603	4813978A25	DIODE
C751	2113946J03	10 UF	C801	2113944A32	39PF	C861	2113945B02	10,000PF	D662	4813978A25	DIODE
C752	2113944A40	100PF	C802	2113945C20	0.016 UF	C862	2113945B02	10,000PF	D700	4813978B18	DIODE
C753	2113944A40	100PF	C803	2113944A32	39PF	C863	2113945B02	10,000PF	E101	2415954H01	INDUCTOR BEAD CHIP
C754	2113946E02	1 UF	C804	2113946E02	1 UF	C864	2113945B02	10,000PF	E102	2405688Z01	INDUCTOR FERRITE BEAD
C755	2113946E02	1 UF	C805	2113945C20	0.016 UF	C865	2113945B02	10,000PF	E401	2480640Z01	SURFACE MOUNT FERRITE BEAD
C756	2113944A40	100PF	C806	2113946K02	0.1 UF	C866	2113945B02	10,000PF	E402	2480640Z01	SURFACE MOUNT FERRITE BEAD
C757	2113944A40	100PF	C807	2113946K02	0.1 UF	C867	NOTPLACED		E403	2480640Z01	SURFACE MOUNT FERRITE BEAD
C758	2113946E02	1 UF	C808	2113946K02	0.1 UF	C868	NOTPLACED		E404	2480640Z01	SURFACE MOUNT FERRITE BEAD
C759	2113946E02	1 UF	C809	2113945C20	0.016 UF	CR101	4815897H01	PIN DIODE	E405	2480640Z01	SURFACE MOUNT FERRITE BEAD
C760	2113944A40	100PF	C810	2113946E02	1 UF	CR102	4815897H01	PIN DIODE	E406	2480640Z01	SURFACE MOUNT FERRITE BEAD
C761	2113944A40	100PF	C811	2113946K02	0.1 UF	CR800	4813978A25	DIODE,	E407	2480640Z01	SURFACE MOUNT FERRITE BEAD
C762	2113945C31	0.1 UF	C812	2113946K02	0.1 UF	CR801	4813978A25	DIODE	E408	2480640Z01	SURFACE MOUNT FERRITE BEAD
C763	2113944A40	100PF	C813	2113946K02	0.1 UF	D1	4813974A19	DIODE	E409	2480640Z01	SURFACE MOUNT FERRITE BEAD
C764	2113946B03	0.068UF 10V 10	C814	2113946K02	0.1 UF	D103	4813974A05	DIODE	E500	2405688Z01	INDUCTOR FERRITE BEAD
C765	2113946B03	0.068UF 10V 10	C815	2113946K02	0.1 UF	D104	4816487H01	SWITCHING DIODE	E501	2405688Z01	INDUCTOR FERRITE BEAD
C766	2113944A40	100PF	C816	2113946K02	0.1 UF	D201	4815011H01	DIODE	E800	2480574F01	IND FERRITE CHIP 60OHM 0603
C767	2113944A40	100PF	C817	2113946K02	0.1 UF	D202	4815011H01	DIODE			
C768	2113944A40	100PF	C818	2113946K02	0.1 UF	D210	4805656W87	DIODE			
C769	2113944A40	100PF	C830	2113946K02	0.1 UF	D211	4805656W87	DIODE			
C770	2113945C31	0.1 UF	C840	2113946F03	4.7 UF	D212	4805656W87	DIODE			
C771	2113945C31	0.1 UF	C850	2113945A03	330 PF	D401	4815096H01	VARACTOR DIODE 1SV305			
C773	2113946K02	0.1 UF	C851	2113944A40	100 PF	D402	4885055Y01	DIODE VARACTOR PB-FREE			
C780	NOTPLACED		C855	NOTPLACED		D501	4809118D02	LED			
C790	2113946A02	0.022UF	C856	NOTPLACED		D510	NOTPLACED				
C791	2113946K02	0.1 UF	C857	NOTPLACED							

ITEM	MOTOROLA PART NUMBER	DESCRIPTION
E801	2480574F01	IND FERRITE CHIP 60OHM 0603
E802	0613952G67	CER CHIP RES 0.0 +/- 0.050 OHM
F500	6515076H01	FUSE CHIP SMT TR/ 1608FF 3A
FL1	9116647H01	LC FLTR, MULTILAYER CERAMIC
FL2	9116647H01	LC FLTR, MULTILAYER CERAMIC
FL3	4885631B01	XTAL FILT 3 POLE 109.65 MOTORO
FL200	9116848H01	FLTR SW CAP 3 POLE BUTTERW, W18
J101	2880658Z08	CONNECTOR, SMA
J601	0916287H01	CONN VERT 45 PIN ZIF
J650	0916287H02	CONN 20 PIN ZIF
L1	2414017G19	100NH
L2	2415429H33	CHIP INDUCTOR
L4	2488090Y14	12NH
L5	2488090Y12	8.2NH
L6	2488090Y14	12NH
L7	NOTPLACED	
L10	2415429H32	CHIP INDUCTOR
L11	2414017N22	68NH
L12	2414032F40	330NH
L13	2414032F42	470NH
L14	2414032F38	220NH,
L15	NOTPLACED	
L16	2415429H43	CHIP INDUCTOR
L101	2414032F36	150NH

ITEM	MOTOROLA PART NUMBER	DESCRIPTION
L102	NOTPLACED	
L103	2460591D24	COIL AIR WOUND INDUC 19.61
L104	2460591A11	COIL AIR WOUND INDUC 7.66
L106	0613952G67	RES 0.0 OHM
L107	2414017G19	100NH
L108	2414017G18	82NH
L109	2460591B22	COIL AIR WOUND INDUC 8.67
L110	2414017G05	6.8NH
L111	2414017G18	82NH
L112	2414017G12	27NH
L113	2415428H03	AIR WOUND INDUCTOR
L114	2460591A11	COIL AIR WOUND INDUC 7.66
L200	2414017Q20	2.2UH
L201	2414017Q20	2.2UH
L203	2414017Q47	1UH
L204	2414032F21	6.8NH
L205	2414017Q20	2.2UH
L210	2414032F36	150NH
L211	2414032F36	150NH
L212	2414032F36	150NH
L214	2414032F36	150NH
L215	2414032F36	150NH
L216	2414032F36	150NH
L217	2414032F36	150NH
L218	2414032F36	150NH
L219	2414032F36	150NH

ITEM	MOTOROLA PART NUMBER	DESCRIPTION
L220	2414032F26	22NH
L221	2414032F24	15NH
L230	2414032F25	18NH
L290	2414017Q47	1UH
L299	NOTPLACED	
L401	2414032D17	150NH
L402	2466505A01	COIL INDUCTOR
L403	2466505A01	COIL INDUCTOR
L405	2414032B76	4700 NH
L406	2414032F73	820NH
L407	2414032F73	820NH
L500	2414017Q42	390NH
L503	2489669V01	100UH
L511	2489669V01	100UH
L651	2414032F75	270NH
L652	2414032F75	270NH
L701	2486085A01	COIL, POWER INDUCTOR
L702	2486085A01	COIL, POWER INDUCTOR
L703	2464675H01	560NH
L704	2464675H01	560NH
L705	2464675H01	560NH
L708	2416307H01	680NH
L710	2416307H01	680NH
M101	3916333H01	GROUND CONTACT
M701	0985888K02	SKT RTC BTTY LEAP
PCB	8416095H01	STINGRAY RUGGED 7/800 MHZ
Q1	4805585Q19	TRANSISTOR

ITEM	MOTOROLA PART NUMBER	DESCRIPTION
Q101	4816698H01	MOD,XSTR,FET RF PWR,950 MHZ
Q210	4813972A15	PB-FREE,NOT COMPLETELY ENRICHED
Q211	4885061Y01	XSTR
Q212	4813972A15	XSTR
Q213	4885061Y01	XSTR
Q214	4813972A15	XSTR
Q215	4885061Y01	XSTR
Q216	4885061Y01	XSTR
Q217	4813972A15	XSTR
Q218	4813972A15	XSTR
Q401	4805585Q28	TRANSISTOR RF NPN 8GHZ NOPB
Q501	4805921T28	XSTR, DUAL NOPB
Q698	4813973A81	XSTR
Q700	4813970A62	XSTR
Q701	4813973M07	XSTR
Q702	5185956E76	IC,CONV,SM,SO16,0-30 VINUT RANGE,6.5A,3.8V
Q703	4813970A62	XSTR,FET GP PWR,MOSFET,P-CH,ENHN,CF,-20V,1.3W
Q704	NOTPLACED	
Q705	NOTPLACED	
Q706	NOTPLACED	
Q709	4885061Y01	XSTR
Q801	4813973A42	XSTR
Q804	4813973A81	XSTR
R1	0613952Q66	510 OHM

ITEM	MOTOROLA PART NUMBER	DESCRIPTION	ITEM	MOTOROLA PART NUMBER	DESCRIPTION	ITEM	MOTOROLA PART NUMBER	DESCRIPTION	ITEM	MOTOROLA PART NUMBER	DESCRIPTION
R2	0613952Q93	6800 OHM 5% 0402	R121	0613952H73	1000 OHM 5% 0603	R231	0613952Q31	18.0 OHM 5% 0402	R297	0613952R66	0.0 0.050 OHM
R3	0613952Q89	4700 OHM 5 0402	R200	0613952Q49	100 OHM 5 0402	R232	0613952R18	51K OHM 5% 0402	R298	NOTPLACED	
R4	0613952Q83	2700 OHM 5% 0402	R201	0613952Q53	150 OHM 5% 0402	R233	0613952Q57	220 OHM 5% 0402	R299	NOTPLACED	
R5	0613952Q58	240 OHM 5% 0402	R202	0613952Q53	150 OHM 5% 0402	R234	0613952R08	20K OHM 5% 0402	R401	0613952Q49	100 OHM 5 0402
R7	0613952Q39	33.0 OHM 5% 0402	R204	0613952R66	0.0 +/-0.050 OHM	R235	0613952R08	20K OHM 5% 0402	R402	0613952R10	24K OHM 5 0402
R10	0613952R66	0.0 +/-0.050 OHM	R205	0613952Q87	3900 OHM 5% 0402	R236	0613952Q31	18.0 OHM 5% 0402	R403	0613952Q94	7500 OHM 5% 0402
R11	0613952Q37	33.0 OHM 5% 0402	R206	0613952Q48	91.0 OHM 5% 0402	R237	0613952Q57	220 OHM 5% 0402	R404	0613952C81	681 OHM 1% 0603
R20	NOTPLACED		R207	0613952Q57	220 OHM 5% 0402	R238	0613952Q49	100 OHM 5 0402	R405	0613952Q80	2000 OHM 5% 0402
R30	0613952R66	0.0 0.050 OHM	R208	0613952Q73	1000 OHM 5% 0402	R239	0613952R10	24K OHM 5 0402	R406	0613952Q70	330 OHM 5% 0402
R40	0613952G67	0.0 0.050 OHM	R210	0613952Q73	1000 OHM 5% 0402	R241	0613952R66	0.0 0.050 OHM	R407	0613952R10	24K OHM 5 0402
R100	0613952H53	150 OHM 5% 0603	R211	0613952R66	0.0 0.050 OHM	R243	0613952R12	30K OHM 5% 0402	R408	0613952Q41	47.0 OHM 5% 0402
R101	0613952H42	51.0 OHM 5% 0603	R212	0613952Q37	33.0 OHM 5% 0402	R244	0613952R18	51K OHM 5% 0402	R409	0613952R25	100K OHM 5% 0402
R103	0613952H53	150 OHM 5% 0603	R213	0613952R66	0.0 0.050 OHM	R250	0613952R66	0.0 0.050 OHM	R410	0613952R01	10K OHM 5% 0402
R104	0613952Z22	220 1% 1/16W	R214	0613952R08	20K OHM 5% 0402	R251	0613952R66	0.0 0.050 OHM	R411	0613952Q63	390 OHM 5% 0402
R105	0613952H42	51.0 OHM 5% 0603	R215	0613952R19	56K OHM 5% 0402	R252	0613952R66	0.0 0.050 OHM	R412	0613952R01	10K OHM 5% 0402
R106	0613952H53	150 OHM 5% 0603	R216	0613952R17	47K OHM 5% 0402	R261	0613952R18	51K OHM 5% 0402	R413	0613952R66	0.0 0.050 OHM
R107	0613952H63	390 OHM 5% 0603	R217	0613952Q49	100 OHM 5 0402	R262	0613952Q91	5600 OHM 5 0402	R414	0613952R25	100K OHM 5% 0402
R108	0613952R04	15K OHM 5% 0402	R220	0613952Q61	330 OHM 5% 0402	R285	0613952Q80	2000 OHM 5% 0402	R415	0613952R66	0.0 0.050 OHM
R109	0613952Q80	2000 OHM 5% 0402	R221	0613952R18	51K OHM 5% 0402	R286	0613952Q45 (PMLF4040A)	68.0 OHM 5% 0402	R416	NOTPLACED	
R110	0613952R15	39K OHM 5% 0402	R222	0613952Q25	10.0 OHM 5% 0402		0613952K81 (PMLF4040B)	68.0 OHM 1% 0402	R503	0613952Q63	390 OHM 5% 0402
R111	NOTPLACED		R223	0613952R08	20K OHM 5% 0402	R289	0613952Q37	33.0 OHM 5% 0402	R504	0613952Q66	510 OHM 5% 0402
R113	NOTPLACED		R224	0613952R08	20K OHM 5% 0402	R290	0613952R13	33K OHM 5% 0402	R505	0613952Q93	6800 OHM
R114	0613952R66	0 5 20X40	R225	0613952Q37	33.0 OHM 5% 0402	R291	0613952R13	33K OHM 5% 0402	R507	0613952Q49	100 OHM 5 0402
R115	0613952Q93	6800 OHM 5% 0402	R226	0613952Q17	4.7 OHM 5% 0402	R292	0613952Q37	33.0 OHM 5% 0402	R508	0613952Q49	100 OHM 5 0402
R117	0613952R25	100K OHM 5% 0402	R227	0613952R18	51K OHM 5% 0402	R293	0613952Q95	8200 OHM 5% 0402	R509	0613952Q49	100 OHM 5 0402
R118	0613952R32	200K OHM 5% 0402	R228	0613952Q55	180 OHM 5% 0402	R294	0613952R66	0.0 0.050 OHM	R510	0613952Q49	100 OHM 5 0402
R119	0613952Q93	6800 5% 20X40	R229	0613952R08	20K OHM 5% 0402	R295	0613952R17	47K OHM 5% 0402	R511	0613952R01	10K OHM 5% 0402
R120	0613952Q53	150 OHM 5% 0402	R230	0613952R08	20K OHM 5% 0402				R512	0613952R17	47K OHM 5% 0402

ITEM	MOTOROLA PART NUMBER	DESCRIPTION
R520	0613952R37	330K OHM 5% 0402
R530	0613952R01	10K OHM 5% 0402
R531	0613952R01	10K OHM 5% 0402
R532	0613952R01	10K OHM 5% 0402
R533	0613952R01	10K OHM 5% 0402
R534	0613952R01	10K OHM 5% 0402
R535	0613952R01	10K OHM 5% 0402
R536	0613952R01	10K OHM 5% 0402
R537	0613952R01	10K OHM 5% 0402
R540	NOTPLACED	
R545	0613952R17	47K OHM 5% 0402
R546	0613952R17	47K OHM 5% 0402
R547	0613952R17	47K OHM 5% 0402
R594	NOTPLACED	ART NUMBER
R595	0613952R66	0.0 0.050 OHM
R608	0613952Q49	100 OHM 5 0402
R610	NOTPLACED	
R611	0613952Q49	100 OHM 5 0402
R613	0613952R08	20K OHM 5% 0402
R614	0613952R08	20K OHM 5% 0402
R615	0613952R25	100K OHM 5% 0402
R616	0613952Q49	100 OHM 5 0402
R617	NOTPLACED	
R620	0613952Q49	100 OHM 5 0402
R621	0613952Q49	100 OHM 5 0402
R622	0613952Q49	100 OHM 5 0402
R625	0613952Q49	100 OHM 5 0402
R626	0613952Q49	100 OHM 5 0402

ITEM	MOTOROLA PART NUMBER	DESCRIPTION
R633	NOTPLACED	
R634	0613952R66	0.0 0.050 OHM
R635	NOTPLACED	
R636	0613952R01	10K OHM 5% 0402
R637	0613952Q73	1000 OHM 5% 0402
R638	0613952Q73	1000 OHM 5% 0402
R639	0613952Q73	1000 OHM 5% 0402
R640	0613952Q73	1000 OHM 5% 0402
R641	0613952Q73	1000 OHM 5% 0402
R642	0613952Q73	1000 OHM 5% 0402
R643	0613952Q73	1000 OHM 5% 0402
R644	0613952Q73	1000 OHM 5% 0402
R647	0613952R01	10K OHM 5% 0402
R649	0613952R17	47K OHM 5% 0402
R654	0613952R01	10K OHM 5% 0402
R656	0613952R01	10K OHM 5% 0402
R658	0613952P18	150K OHM 1% 0402
R666	0613952Q42	51.0 OHM 5% 0402
R667	0613952Q63	390 OHM 5% 0402
R668	0613952Q45	68.0 OHM 5 0402
R669	0613952Q49	100 OHM 5 0402
R670	0613952Q49	100 OHM 5 0402
R671	0613952Q63	390 OHM 5% 0402
R672	0613952R01	10K OHM 5% 0402
R673	0613952R01	10K OHM 5% 0402
R674	0613952Q49	100 OHM 5 0402
R675	0613952Q67	560 OHM 5% 0402
R677	0613952R01	10K OHM 5% 0402

ITEM	MOTOROLA PART NUMBER	DESCRIPTION
R678	0613952Q49	100 OHM 5 0402
R697	0613952Q49	100 OHM 5 0402
R700	0613952Q80	2000 OHM 5% 0402
R701	0613952R17	47K OHM 5% 0402
R702	0613952R66	0.0 0.050 OHM
R703	0613952R17	47K OHM 5% 0402
R704	0613952Q49	100 OHM 5 0402
R705	0613952R17	47K OHM 5% 0402
R708	0613952R19	56K OHM 5% 0402
R709	0613952H17	4.7OHM 5%
R710	0688044N04	.1 OHM 1% 2X1.27MM
R711	0613952G67	0.0 0.050 OHM
R712	0613952Q49	100 OHM 5 0402
R714	0688044N04	.1 OHM 1% 2X1.27MM
R717	0613952R66	0.0 0.050 OHM
R718	0613952G67	0.0 0.050 OHM
R722	0613952R08	20K OHM 5% 0402
R725	0613952R66	0.0 0.050 OHM
R726	0613952R66	0.0 0.050 OHM
R729	0613952R13	33K OHM 5% 0402
R740	0613952Q63	390 OHM 5% 0402
R741	0613952R17	47K OHM 5% 0402
R742	0613952R17	47K OHM 5% 0402
R743	NOTPLACED	
R744	NOTPLACED	
R745	0613952R56	2.0M OHM 5 0402
R746	0613952R56	2.0M OHM 5 0402
R747	0613952Q73	1000 OHM 5% 0402

ITEM	MOTOROLA PART NUMBER	DESCRIPTION
R748	0613952R41	470K OHM 5% 0402
R749	0613952R41	470K OHM 5% 0402
R750	0613952Q63	390 OHM 5% 0402
R751	0613952Q63	390 OHM 5% 0402
R752	0613952Q81	2200 OHM 5% 0402
R753	0613952Q81	2200 OHM 5% 0402
R756	0613952R66	0.0 0.050 OHM
R757	0613952R08	20K OHM 5% 0402
R758	0613952R19	56K OHM 5% 0402
R759	0613952R01	10K OHM 5% 0402
R760	0613952Q93	6800 OHM 5% 0402
R763	NOTPLACED	
R764	NOTPLACED	
R765	NOTPLACED	
R767	0613952R66	0.0 0.050 OHM
R768	NOTPLACED	
R771	NOTPLACED	
R772	0613952Q49	100 OHM 5 0402
R773	0613952Q49	100 OHM 5 0402
R774	0613952Q49	100 OHM 5 0402
R775	0613952Q49	100 OHM 5 0402
R776	NOTPLACED	
R777	0613952R01	10K OHM 5% 0402
R778	0613952R01	10K OHM 5% 0402
R779	0613952R01	10K OHM 5% 0402
R780	0613952Q89	4700 OHM 5 0402
R781	0613952R01	10K OHM 5% 0402
R782	0613952R01	10K OHM 5% 0402

ITEM	MOTOROLA PART NUMBER	DESCRIPTION	ITEM	MOTOROLA PART NUMBER	DESCRIPTION	ITEM	MOTOROLA PART NUMBER	DESCRIPTION	ITEM	MOTOROLA PART NUMBER	DESCRIPTION
R783	0613952R01	10K OHM 5% 0402	R815	0613952R66	0.0 0.050 OHM	SH104	2616555H01	SHLD PA	U502	5185941F35	IC, VREG, NOPB
R784	NOTPLACED		R816	0613952R17	47K OHM 5% 0402	SH201	2616560H01	SHLD SYN	U601	5185941F22	IC,OPAMP,SGL,OPA237,SOT23,NOPB
R785	0613952Q49	100 OHM 5 0402	R820	0613952R01	10K OHM 5% 0402	SH202	2616556H01	SHLD FRAN N	U602	5185941F22	IC,OPAMP,SGL,OPA237,SOT23,NOPB
R786	0613952R17	47K OHM 5% 0402	R829	NOTPLACED		SH203	2616553H01	SHLD VCO BOT	U701	5185143E77	IC, MAKO ASIC, CMOS PWR MGMT
R790	0613952R19	56K OHM 5% 0402	R837	0613952Q37	33.0 OHM 5% 0402	SH204	2616551H01	SHLD DAC	U702	5185941F22	IC,OPAMP,SGL,OPA237,SOT23,NOPB
R791	0613952R66	0.0 0.050 OHM	R838	0613952Q37	33.0 OHM 5% 0402	SH205	2616554H01	SHLD VCO TOP	U705	5114000B39	IC,BFR,1PER PKG,SM,SOT-353,PB-FREE
R792	0613952R66	0.0 0.050 OHM	R839	0613952R01	10K OHM 5% 0402	SH401	2616552H01	SHLD ABACUS	U712	5188691V01	IC,ANLG SW,NC7SB3157P6X,SM,S C70-6,
R793	0613952R66	0.0 0.050 OHM	R840	0613952Q66	510 OHM 5% 0402	SH402	2616518H01	SHLD 2ND LO FLTR	U713	5115453H01	RAIL TO RAIL OUTPUT, 8 PIN BGA
R794	0613952R66	0.0 0.050 OHM	R841	0613952R01	10K OHM 5% 0402	T1	2516148H01	XMFR MIXER 5:1	U714	5115453H01	RAIL TO RAIL OUTPUT, 8 PIN BGA
R795	0613952R17	47K OHM 5% 0402	R842	0613952R01	10K OHM 5% 0402	T2	2516372H01	TRANSFORMER, BALUN, MIXER ,25:1	U800	5185941F04	IC, PATRIOT BRAVO, 1.2.2,256BGA, PB-FREE
R796	0613952R66	0.0 0.050 OHM	R843	0613952R41	470K OHM 5% 0402	U1	5164015H81	IC,MXR,DBL BAL GILBERT,CELL,SM	U801	5114000B39	IC,BFR,1PER PKG,SM,SOT-353,PB-FREE
R797	0613952Q41	47.0 OHM 5% 0402	R844	0613952Q61	330 OHM 5% 0402	U2	5185941F45	ATTEN,VAR,14.4DBMIN,15 .6DBMAX	U802	5114000B39	IC,BFR,1PER PKG,SM,SOT-353,PB-FREE
R798	0613952Q61	330 OHM 5% 0402	S500	4085131E03	SWITCH FREQ DUAL FUNCTION	U3	5116349H01	IC INVERTER DUAL SC70	U803	5185956E69	IC,DRAM,64MB,60NS,IC 1.8V 64
R799	0613952R01	10K OHM 5% 0402	S501	1880619Z06	VOL POTENTIOMETER	U101	5115678H01	VHF/UHF/800/900 MHZ LD MOS DRIVER IC	U804	5185941F03	IC,SRAM,8M,512KX16,70N S,SM,FBGA48,1.95V
R801	NOTPLACED		S502	4016618H01	SWITCH SURFACE MOUNT	U102	5185765B26	IC PWR CTRL IN MOS20	VR500	4802245J51	ZENER DIODE
R802	0613952Q49	100 OHM 5 0402	S503	4070354A01	LIGHT TOUCH SWITCH-SMD	U103	5115022H01	IC,TEMP SENS,LM50C,SM,SOT-23	VR501	4813977M19	ZENER DIODE
R803	0613952Q49	100 OHM 5 0402	S504	4070354A01	LIGHT TOUCH SWITCH-SMD	U106	5185368C84	DIRECTIONAL CPLR 7/ 800MHZ	VR502	4809788E21	ZENER DIODE
R804	0613952Q66	510 OHM 5% 0402	S505	4070354A01	LIGHT TOUCH SWITCH-SMD	U201	5116245H01	CC LVFRACN	VR503	4809788E21	ZENER DIODE
R805	0613952R01	10K OHM 5% 0402	S506	4070354A01	LIGHT TOUCH SWITCH-SMD	U202	5185941F40	IC, 12 BIT DAC			
R806	0613952Q66	510 OHM 5% 0402	SH001	2616071H01	SHIELD MIXER	U205	5116411H01	IC,OP AMP,			
R807	0613952R01	10K OHM 5% 0402	SH002	2616550H01	SHLD FITLER	U250	5105750U56	IC PKG DIE VCO BUFFER			
R808	0613952R66	0.0 0.050 OHM	SH101	2616559H01	SHLD PCIC	U401	5185963A85	IC-ABACUS III-LP			
R809	0613952R17	47K OHM 5% 0402	SH102	2616557H01	SHLD HARMONIC BOT	U500	5188493T01	IC,VREG/SWG,LP2989,SM			
R810	0613952R01	10K OHM 5% 0402	SH103	2616558H01	SHLD HARMONIC TOP	U501	5185941F35	IC, VREG, NOPB			
R811	0613952Q66	510 OHM 5% 0402									
R812	0613952R25	100K OHM 5% 0402									
R813	0613952R66	0.0 0.050 OHM									
R814	NOTPLACED										

ITEM	MOTOROLA PART NUMBER	DESCRIPTION
VR504	4809788E21	ZENER DIODE
VR505	4809788E21	ZENER DIODE
VR506	4809788E21	ZENER DIODE
VR507	4809788E21	ZENER DIODE
VR591	4813977A43	DIODE
VR592	4813977A43	DIODE
VR593	4813977A43	DIODE
VR594	4813977A43	DIODE
VR595	4813977A43	DIODE
VR596	4813977A43	DIODE
VR650	4813979P12	DIODE
VR651	4813977A43	DIODE
VR652	4813977A43	DIODE
VR657	4809788E21	DIODE
VR658	4813977C23	DIODE
VR659	4813979P10	DIODE
VR662	4813979P10	DIODE
VR663	4813977M18	DIODE
VR678	4866544A01	DIODE
VR701	4813977M11	DIODE
Y200	4802245J68	OSC, REF 16.8 MHZ 1.5 PPM
Y201	4885426C23	CER RESONATOR 960 MHZ
Y202	4885426C16	CER RESONATOR 1025 MHZ
Y203	4885426C17	CER RESONATOR 1110 MHZ
Y701	4809995L05	XTAL QUARTZ 32.768KHZ CC4V-T1

ITEM	MOTOROLA PART NUMBER	DESCRIPTION
Y702	4864005H01	RESONATOR, CRYSTAL 24.576 MHZ

Notes:

- For optimum performance, order replacement diodes, transistors, and circuit modules by Motorola part number only.
- When ordering crystals, specify carrier frequency, crystal frequency, crystal type number, and Motorola part number.
- Part value notations:
 $p=10^{-12}$
 $n=10^{-9}$
 $\mu=10^{-6}$
 $m=10^{-3}$
 $k=10^3$
 $M=10^6$
- ITEM refers to the component reference designator. SIDE refers to the location of the component on the board; S1=Side 1, S2=Side 2.
- The PMLD4303A RF Board uses a 6-layer printed circuit board.

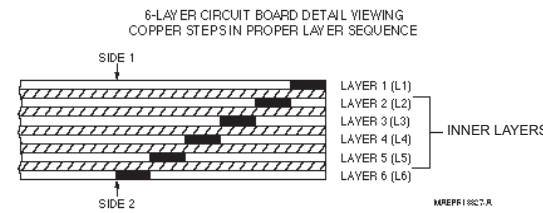

Chapter 9.5 900MHz Schematics, Board Overlays, and Parts Lists

9.5.1 Introduction

This chapter contains the schematics, board layouts, and parts lists for the XTS 2500/2500I/2250/1500 radios. Use them in conjunction with the theory of operation and the troubleshooting procedures, charts, and waveforms to isolate a problem to the component level.

Table 9.5-1. 900MHz Schematics, Board Overlays and Parts Lists

Schematic/Board Layout	Page No.
Top Level Schematic (PCB No. 8416005H01)	9.5-2
Controller Interface Schematic	9.5-3
Interface and Accessories Schematic	9.5-4
Side Connector Schematic	9.5-5
Controller Schematic	9.5-6
Patriot Bravo (U800) Schematic	9.5-7
MAKO DC and Audio Schematic - Sheet 1 of 2	9.5-8
MAKO DC and Audio Schematic - Sheet 2 of 2	9.5-9
Memory Schematic	9.5-10
Frequency Generation Unit (FGU) Schematic - Sheet 1 of 3	9.5-11
Frequency Generation Unit (FGU) Schematic - Sheet 2 of 3	9.5-12
Frequency Generation Unit (FGU) Schematic - Sheet 3 of 3	9.5-13
Receiver Schematic - Sheet 1 of 2	9.5-14
Receiver Schematic - Sheet 2 of 2	9.5-15
Transmitter Schematic	9.5-16
Main Circuit Board Component Location Detail - Side 1 (PCB No. 8416005H01-A)	9.5-17
Main Circuit Board Component Location Detail - Side 2 (PCB No. 8416005H01-A)	9.5-18
8416005H01 Main Circuit Board Electrical Parts List	9.5-19

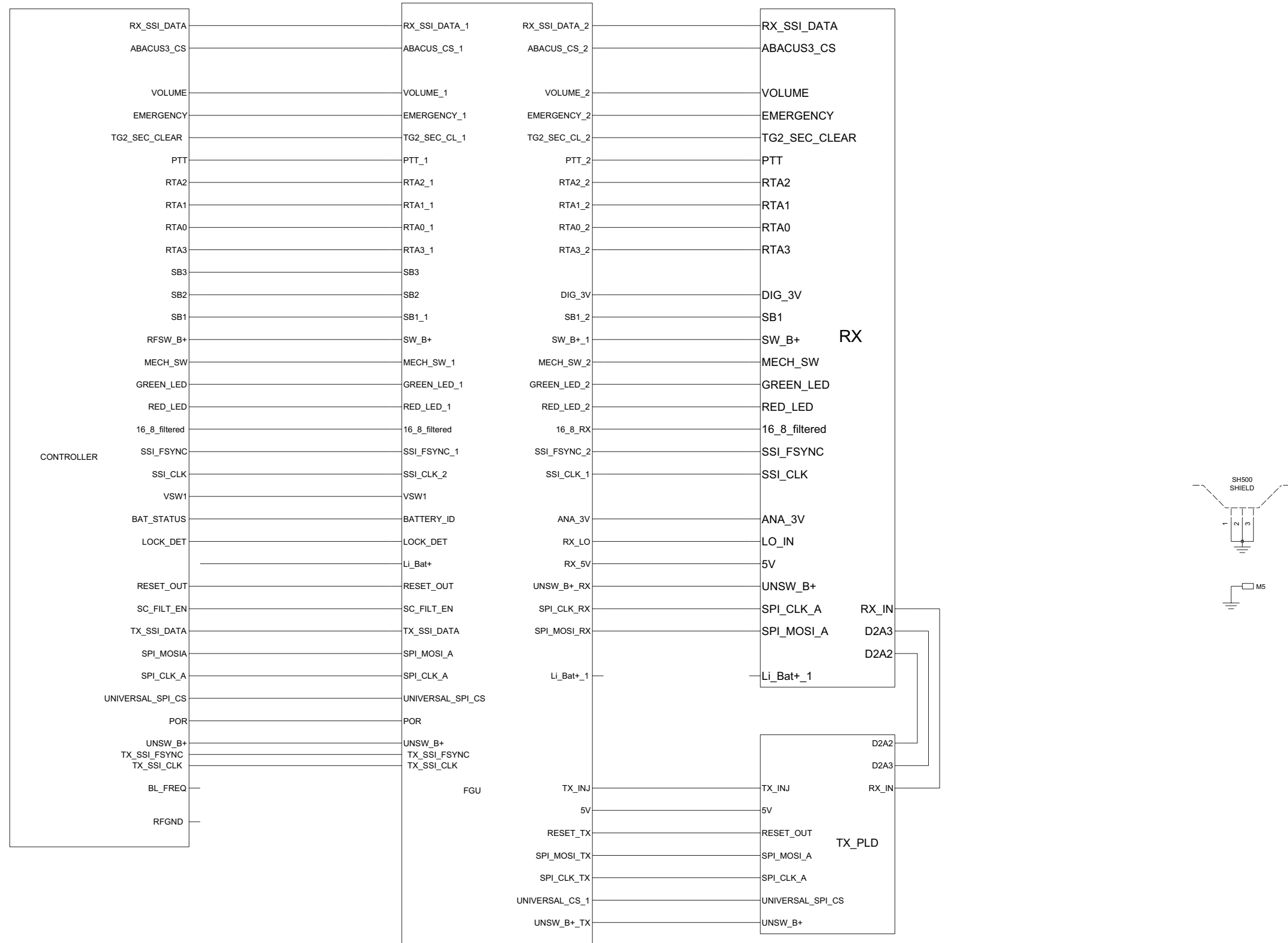

Figure 9.5-1. Top Level Schematic (PCB No. 8416005H01)

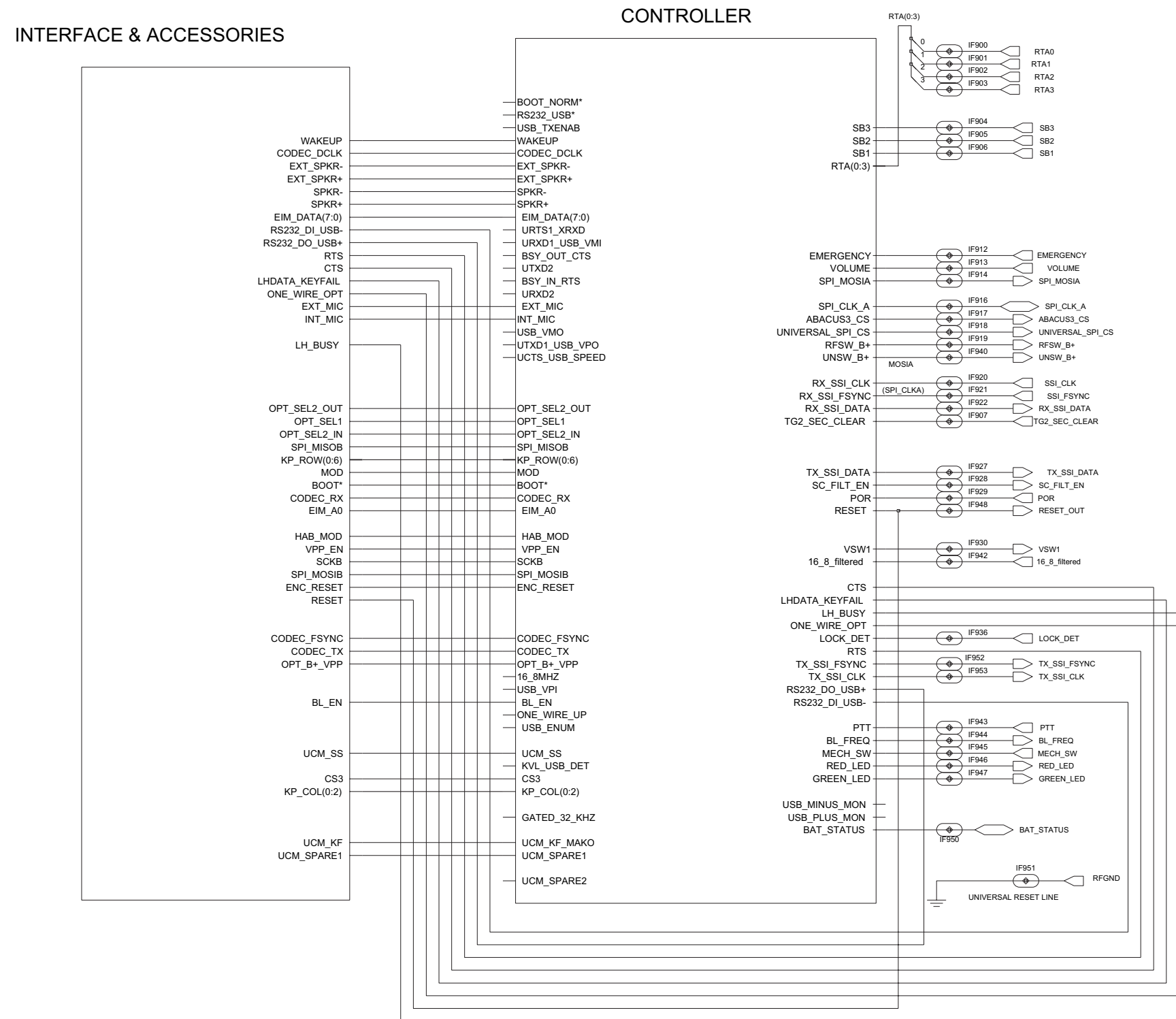

Figure 9.5-2. Controller Interface Schematic

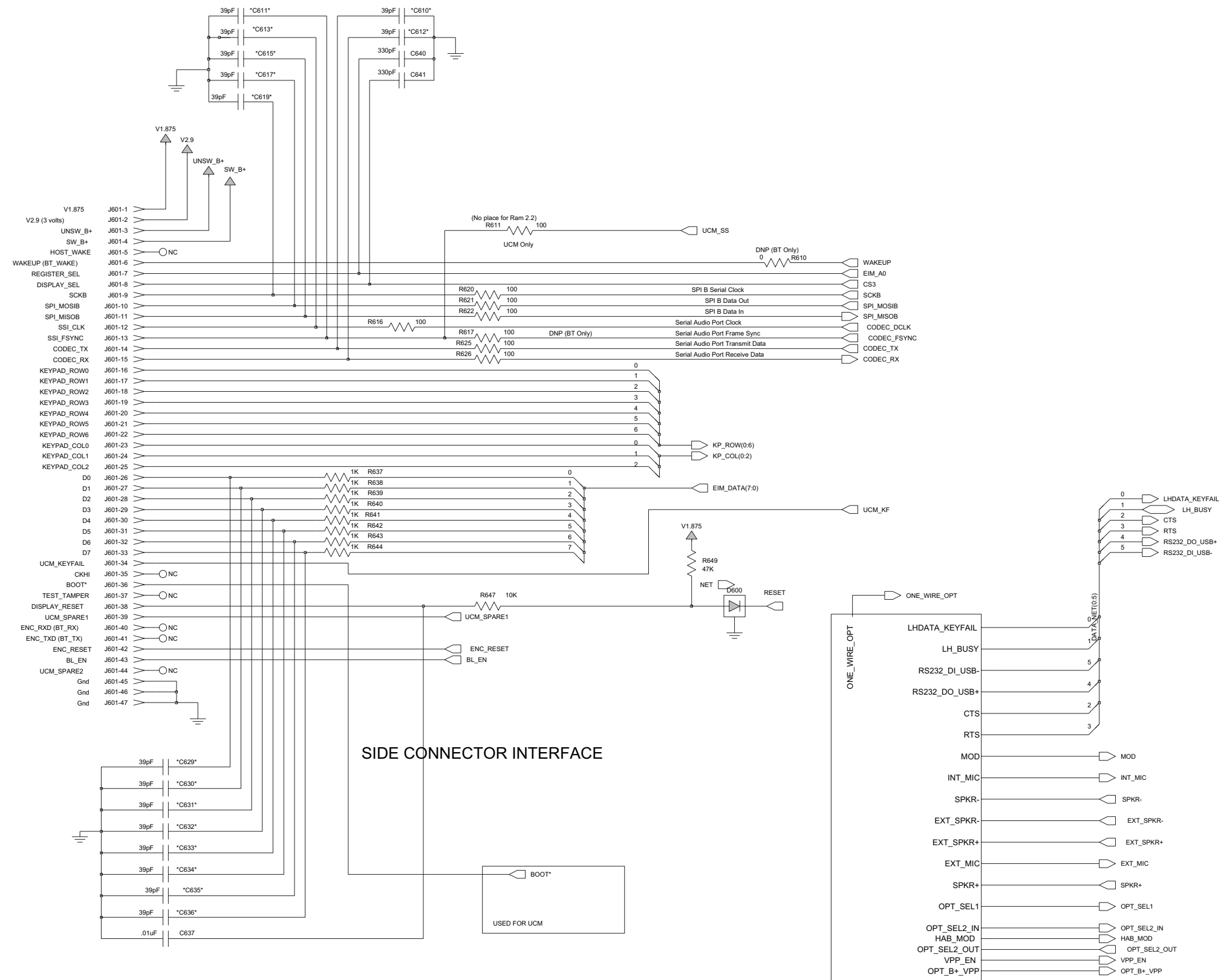

Figure 9.5-3. Interface and Accessories Schematic

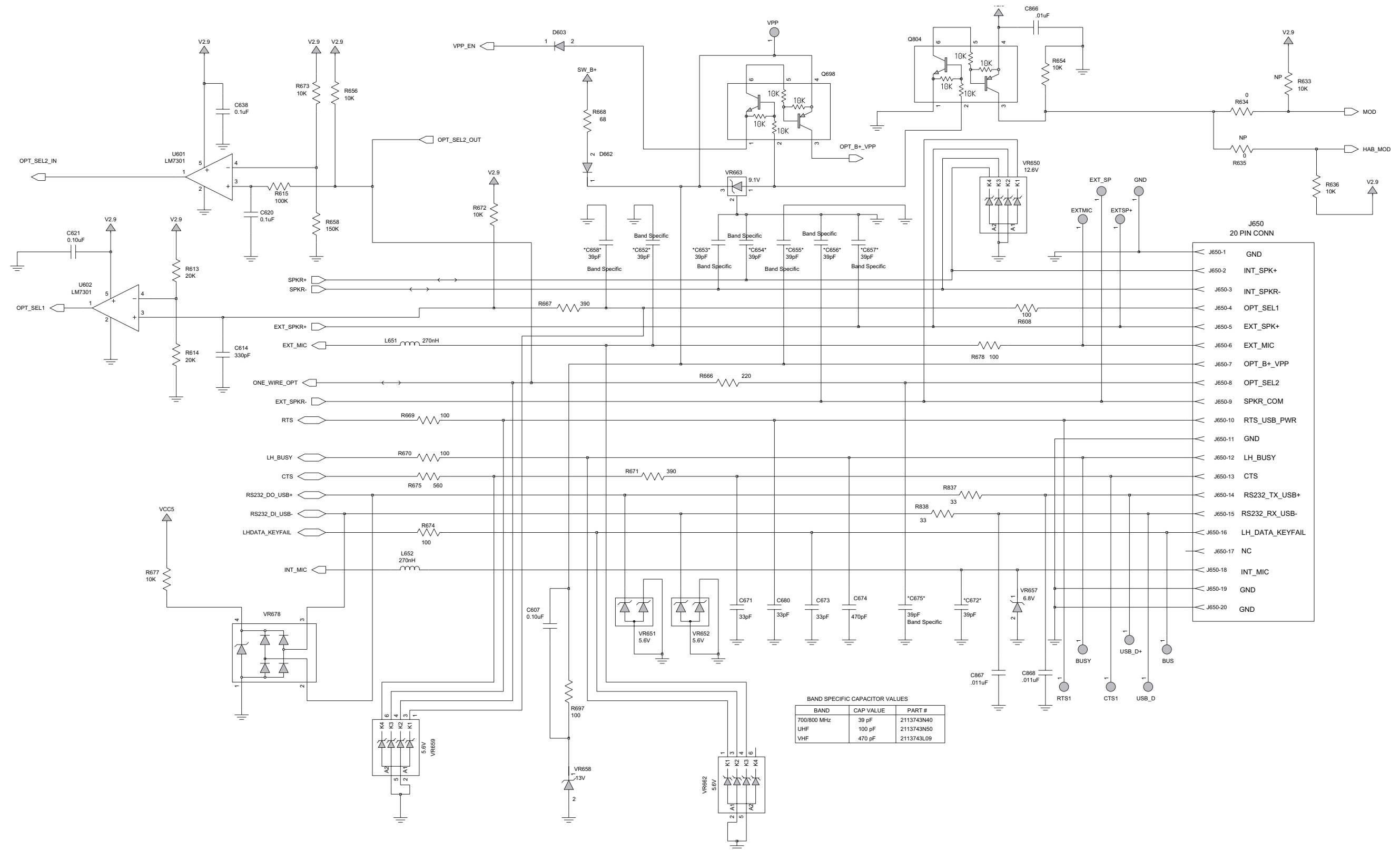

Figure 9.5-4. Side Connector Schematic

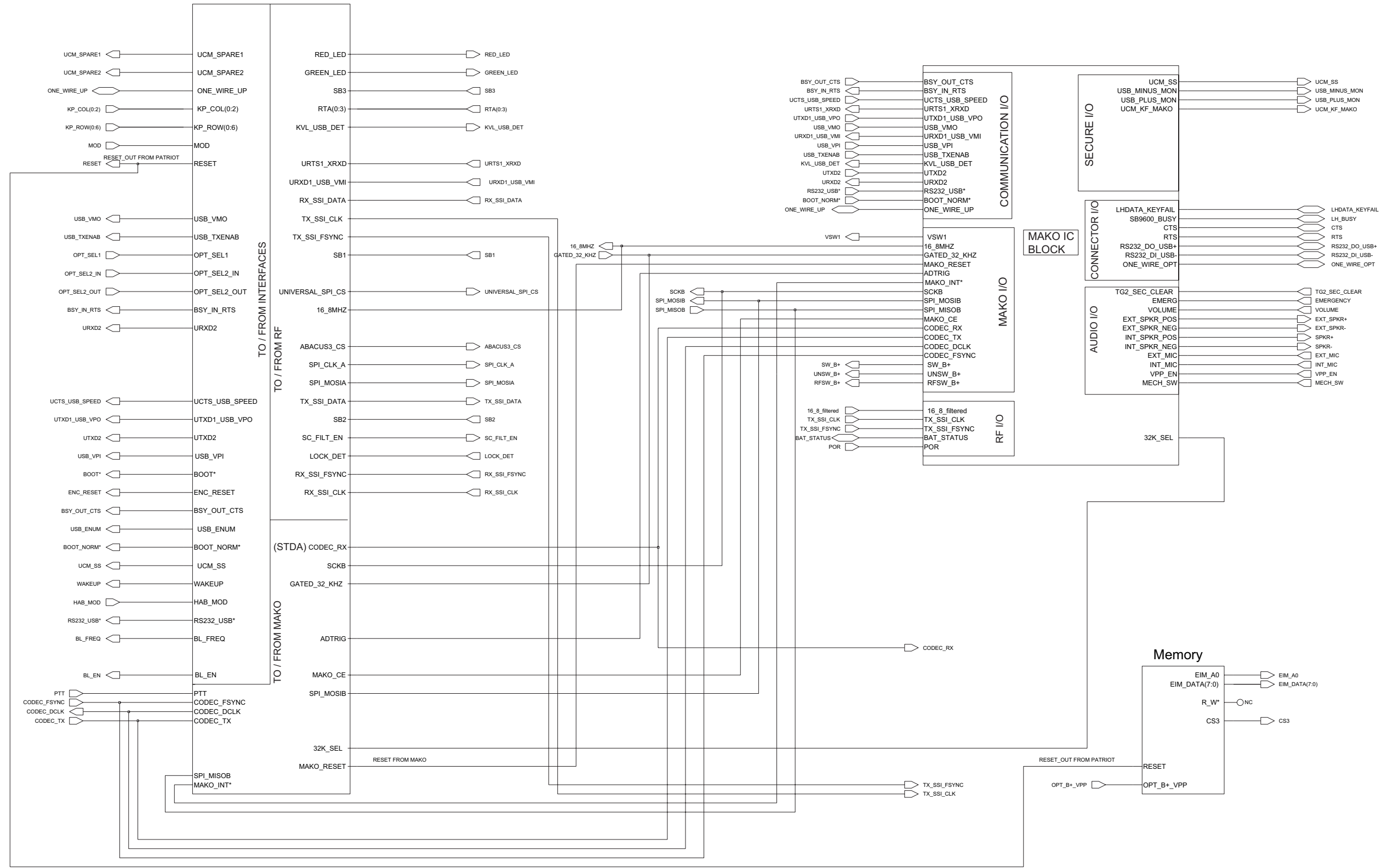

Figure 9.5-5. Controller Schematic

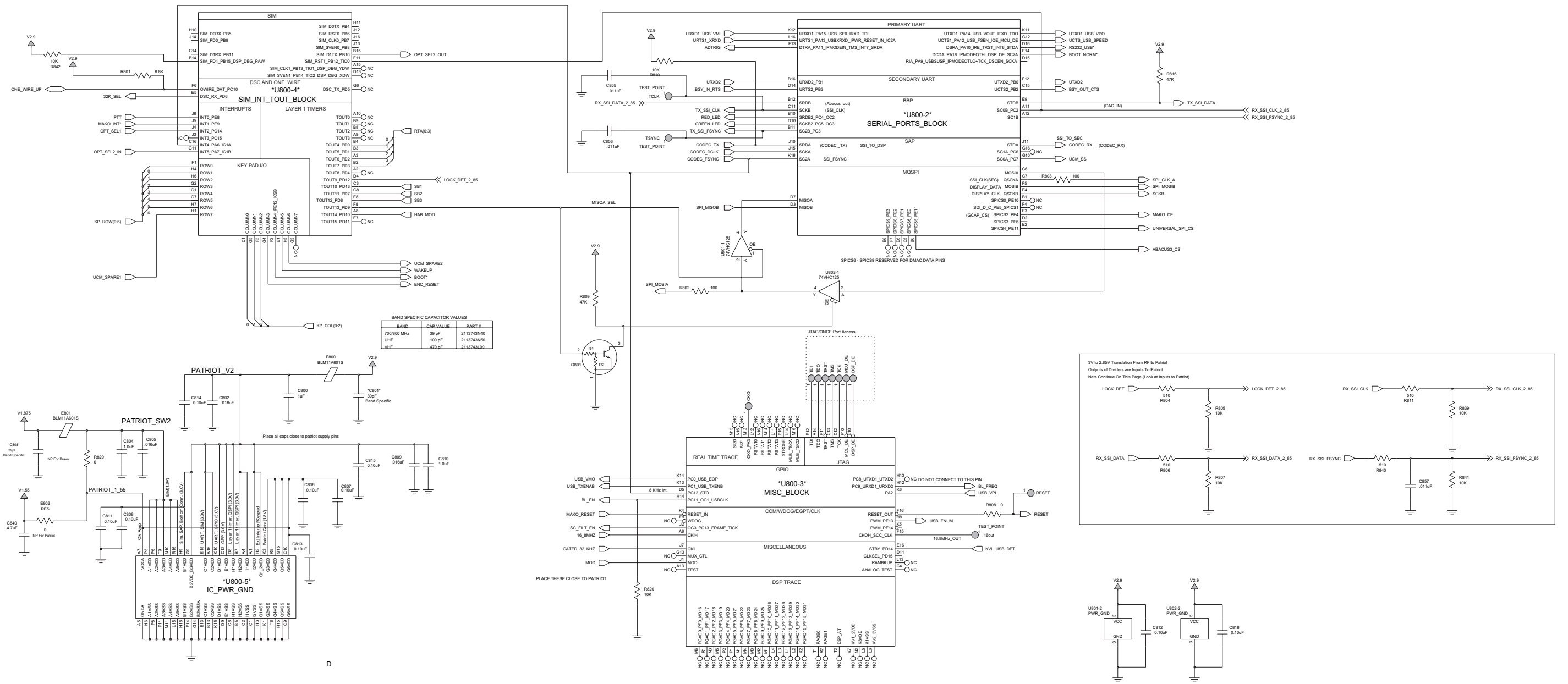

Figure 9.5-6. Patriot Bravo (U800) Schematic

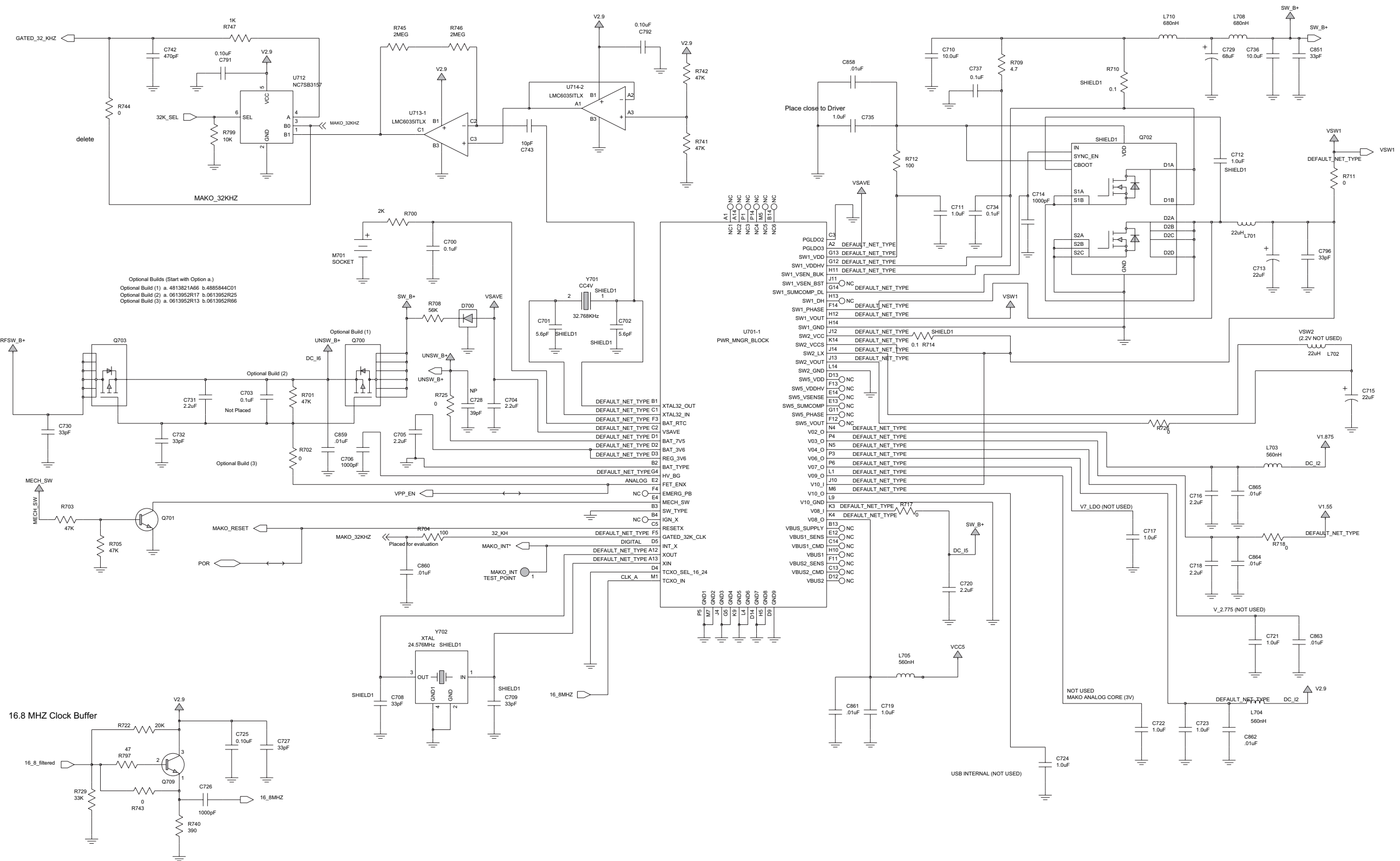

Figure 9.5-7. MAKO DC and Audio Schematic - Sheet 1 of 2

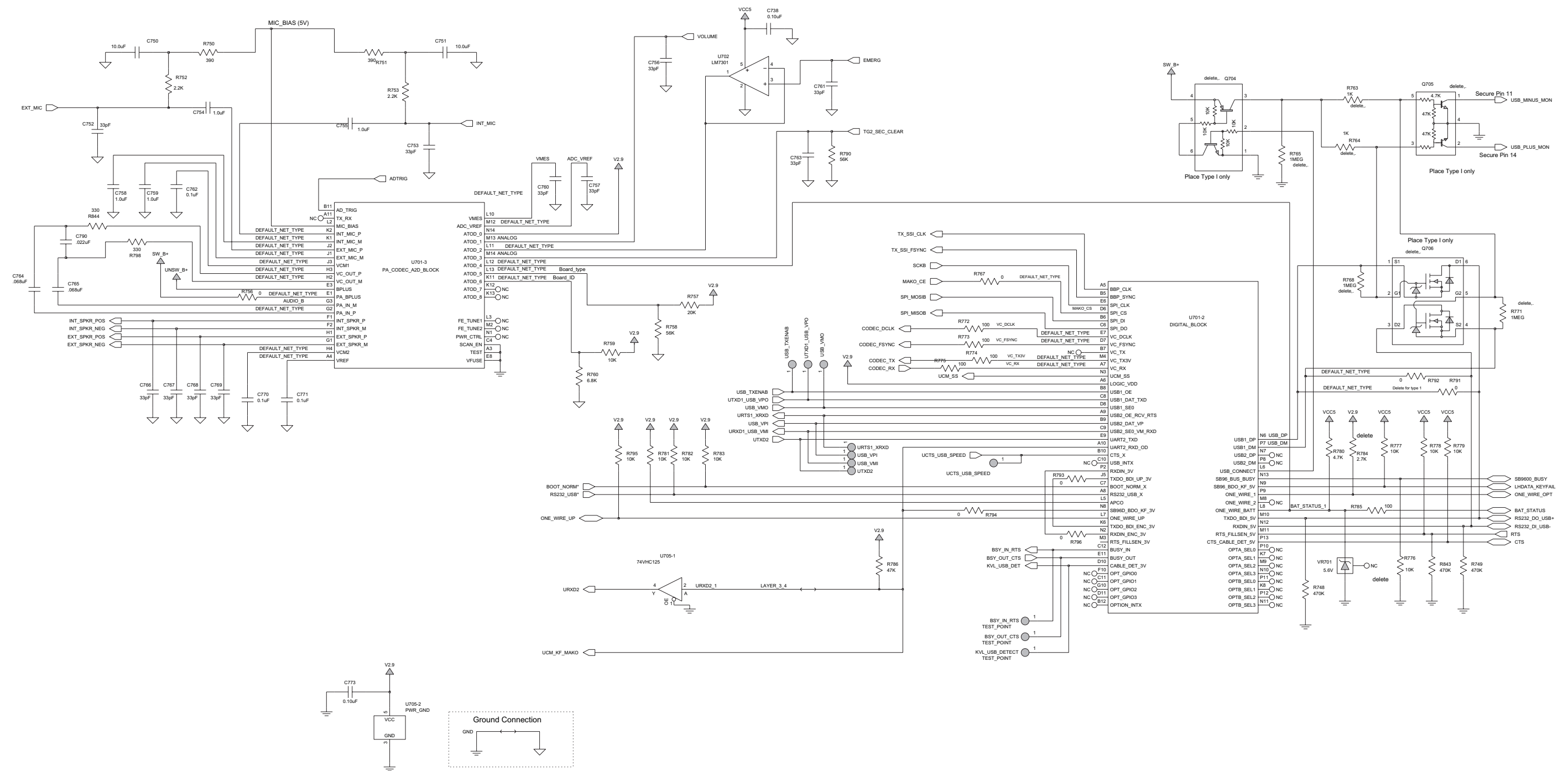

Figure 9.5-8. MAKO DC and Audio Schematic - Sheet 2 of 2

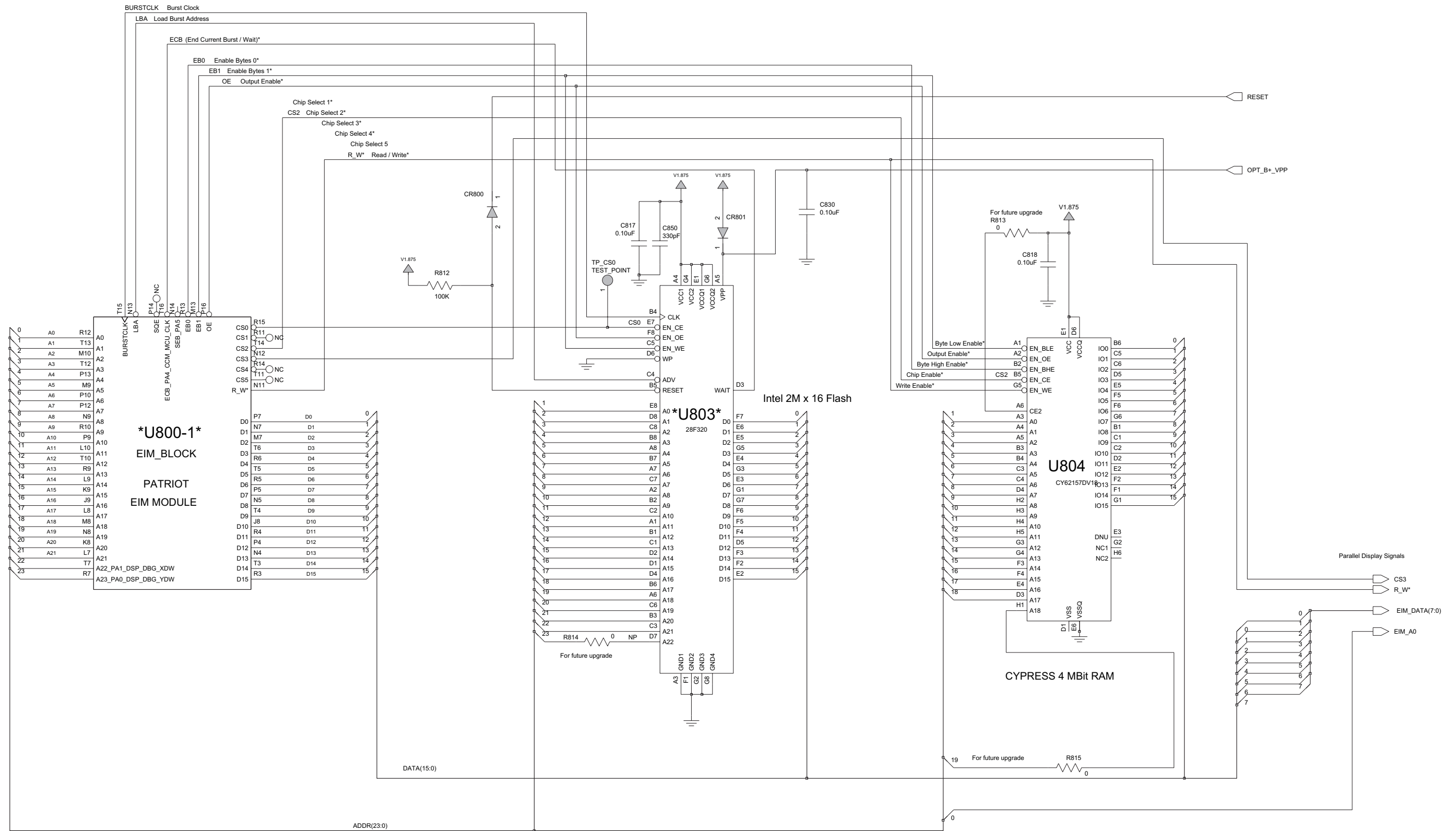

Figure 9.5-9. Memory Schematic

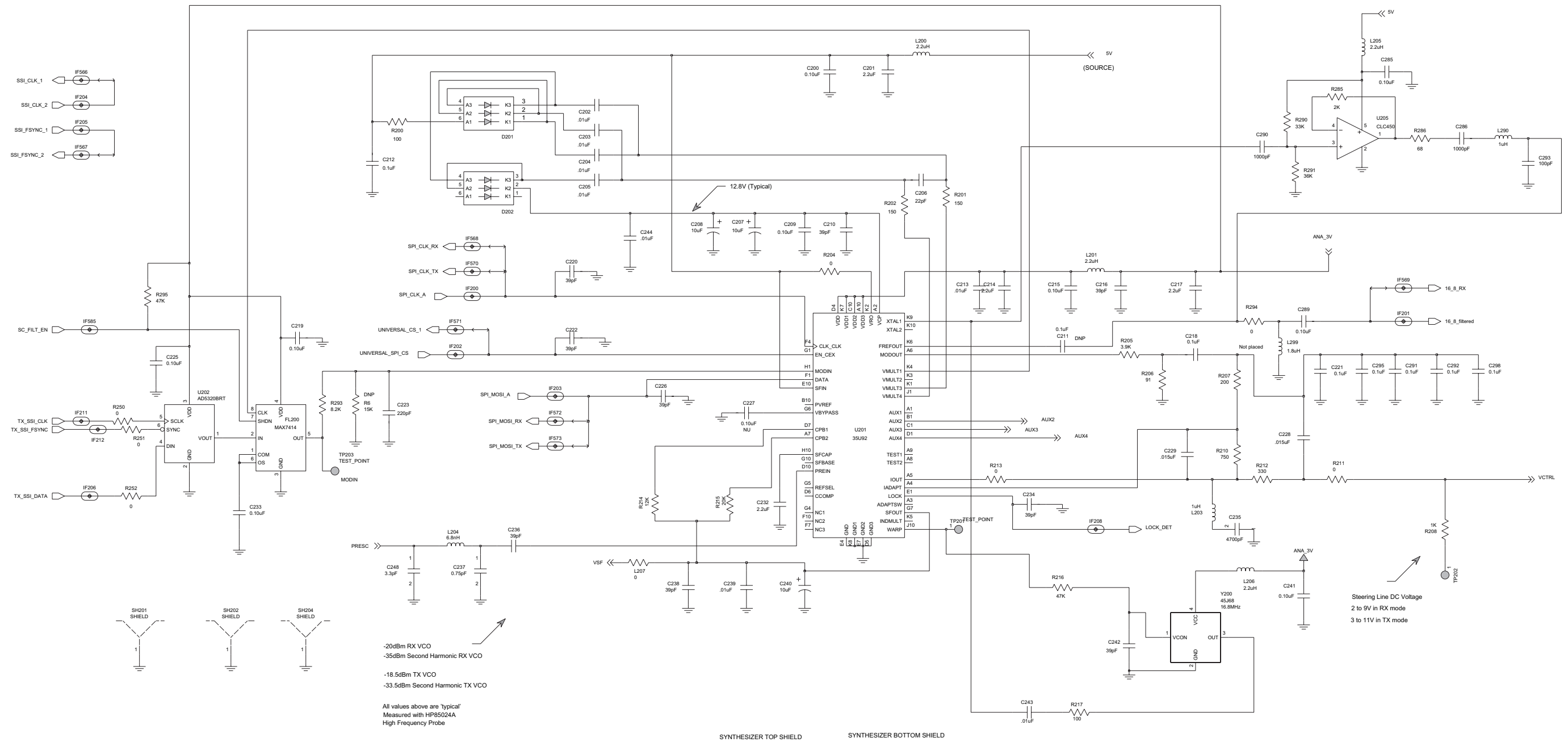

Figure 9.5-10. Frequency Generation Unit (FGU) Schematic - Sheet 1 of 3

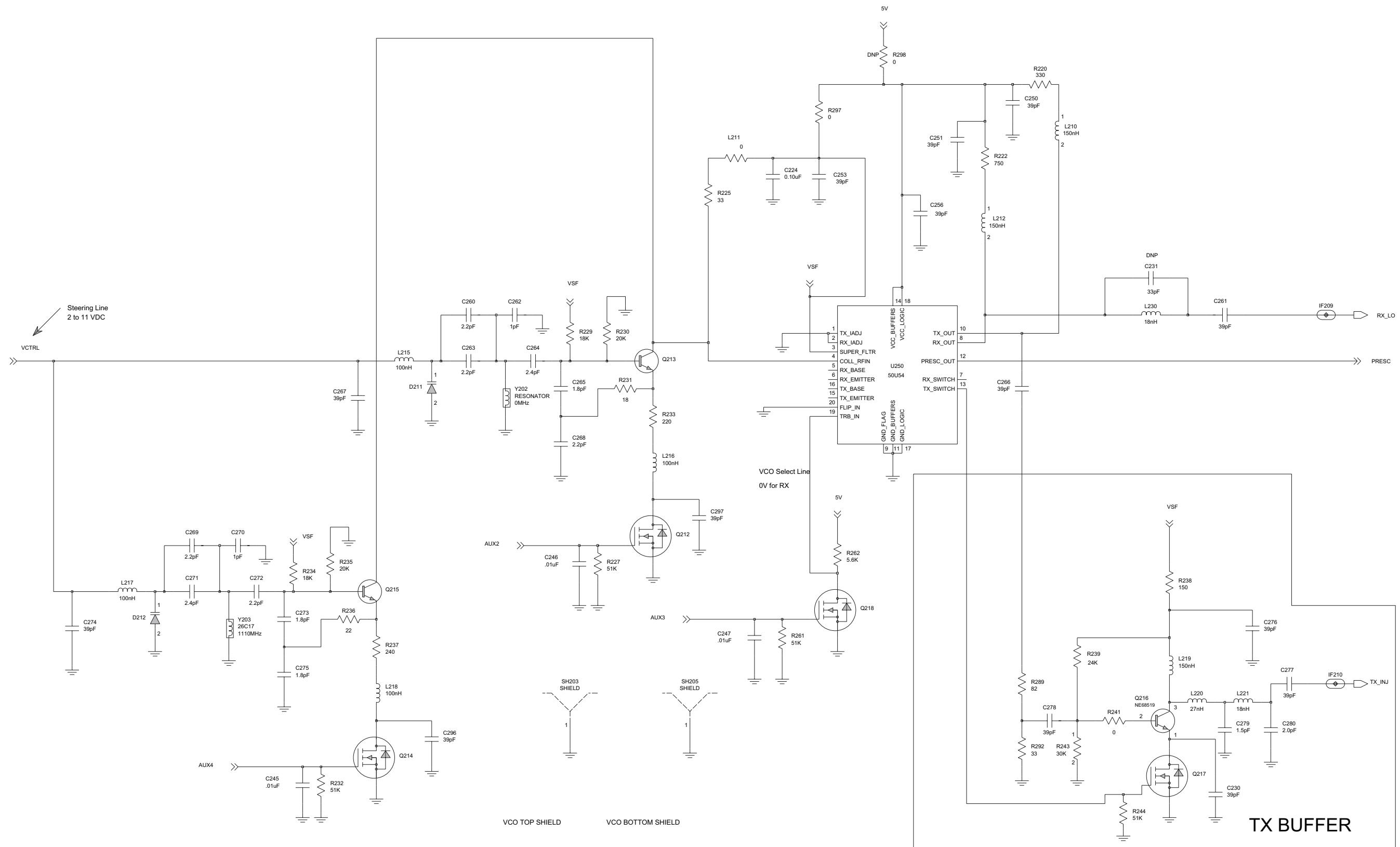

Figure 9.5-11. Frequency Generation Unit (FGU) Schematic - Sheet 2 of 3

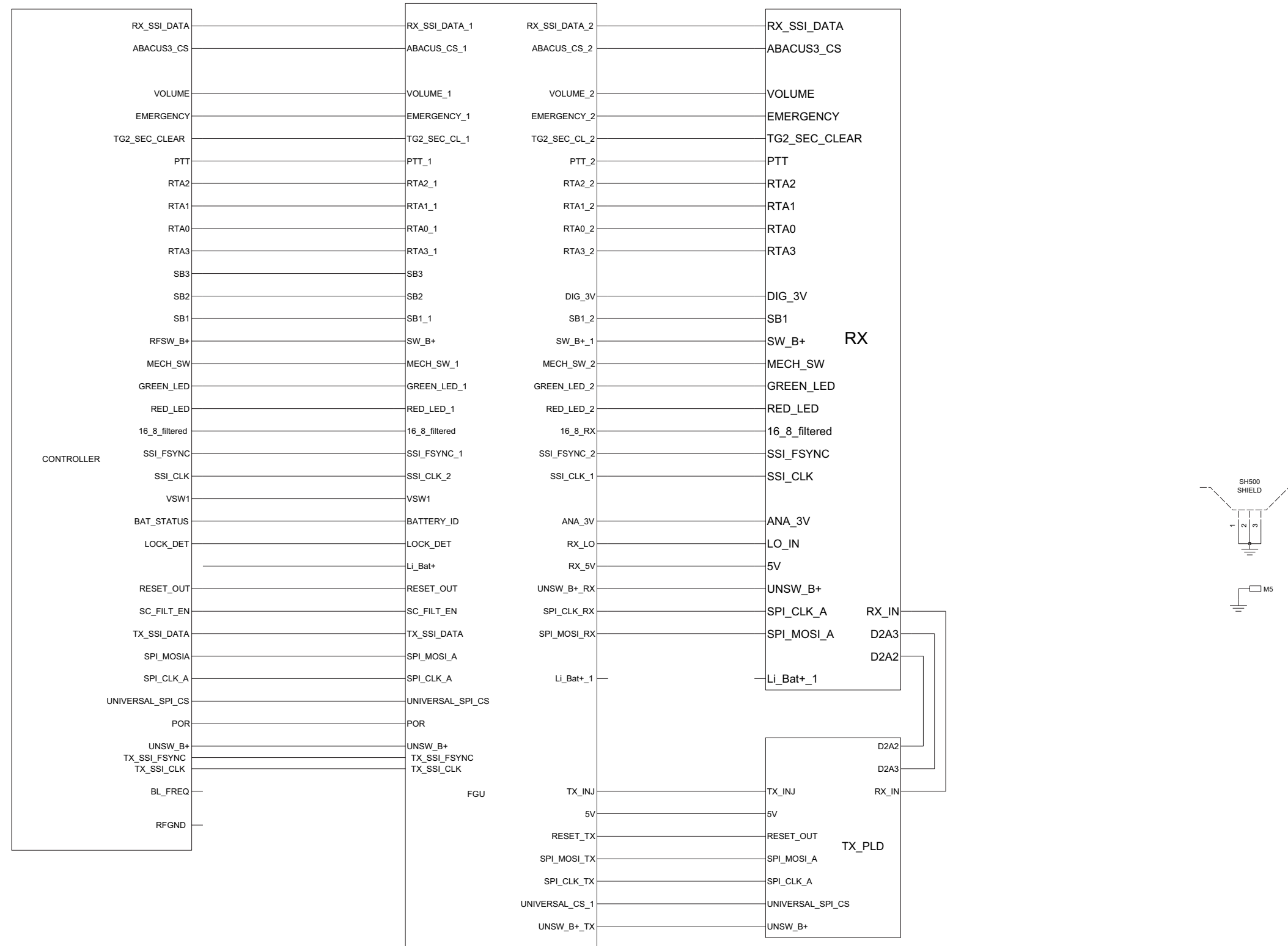

Figure 9.5-12. Frequency Generation Unit (FGU) Schematic - Sheet 3 of 3

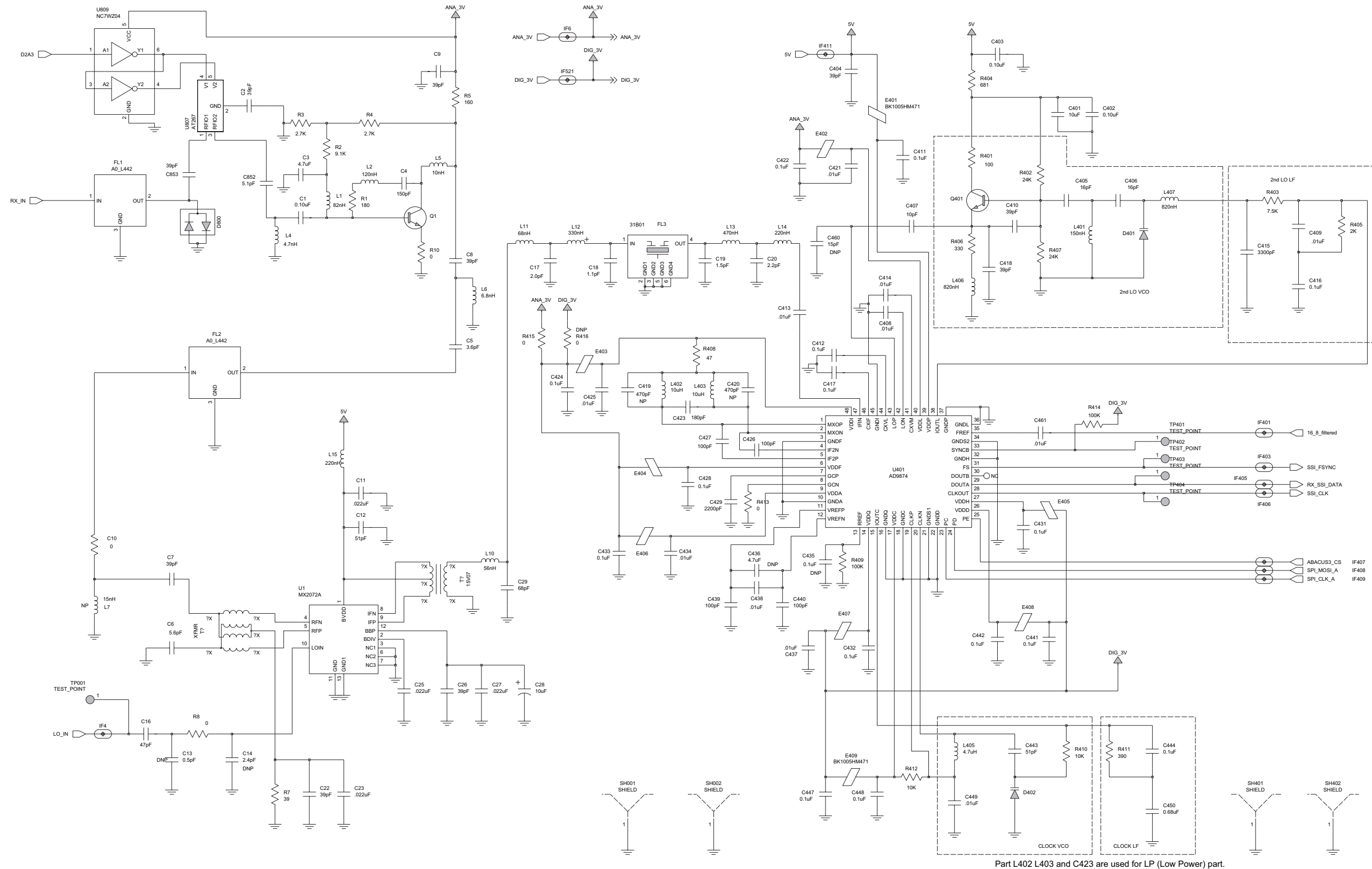
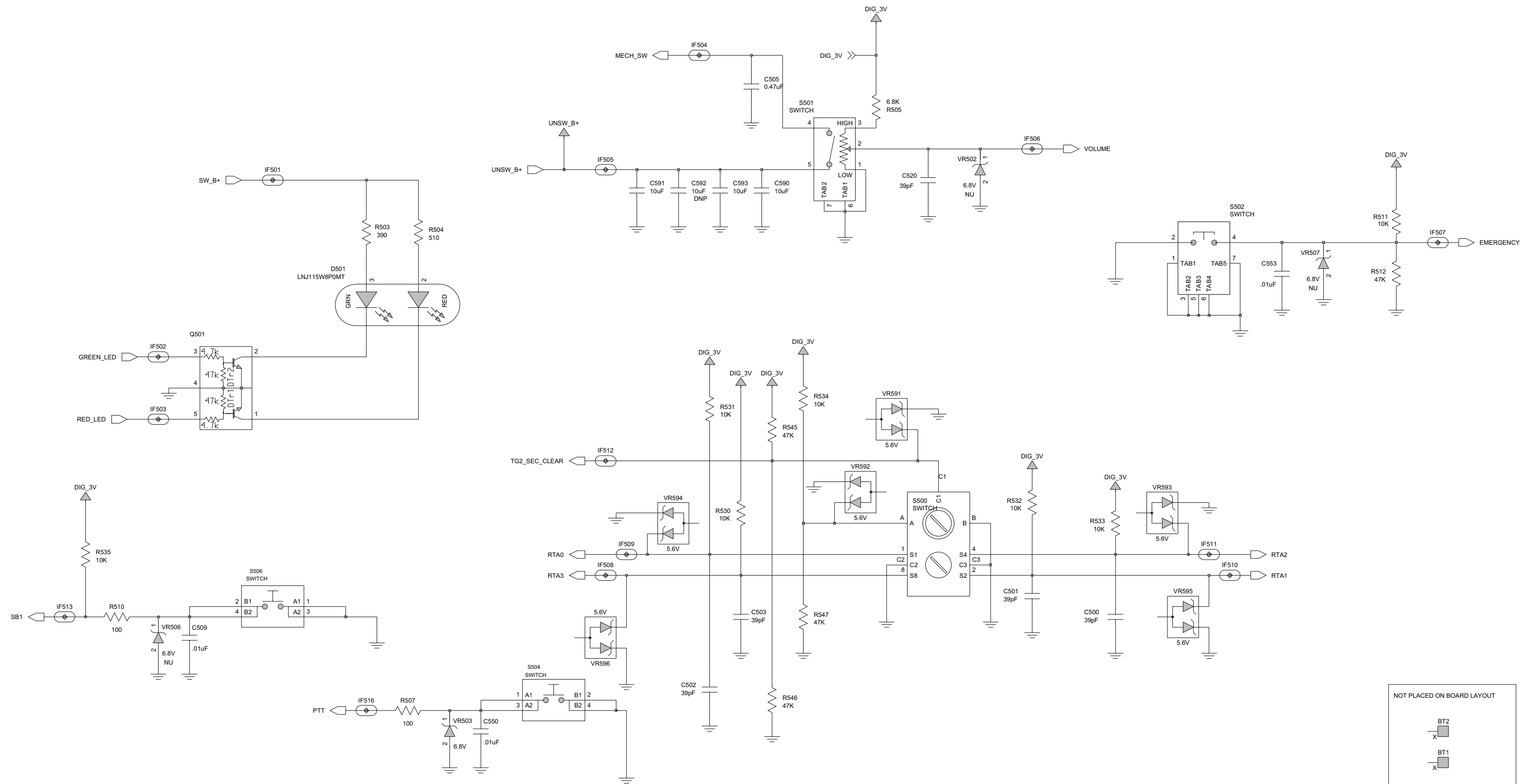

Figure 9.5-13. Receiver Schematic - Sheet 1 of 2



NOT PLACED ON BOARD LAYOUT

BT2
X

BT1
X

Figure 9.5-14. Receiver Schematic - Sheet 2 of 2

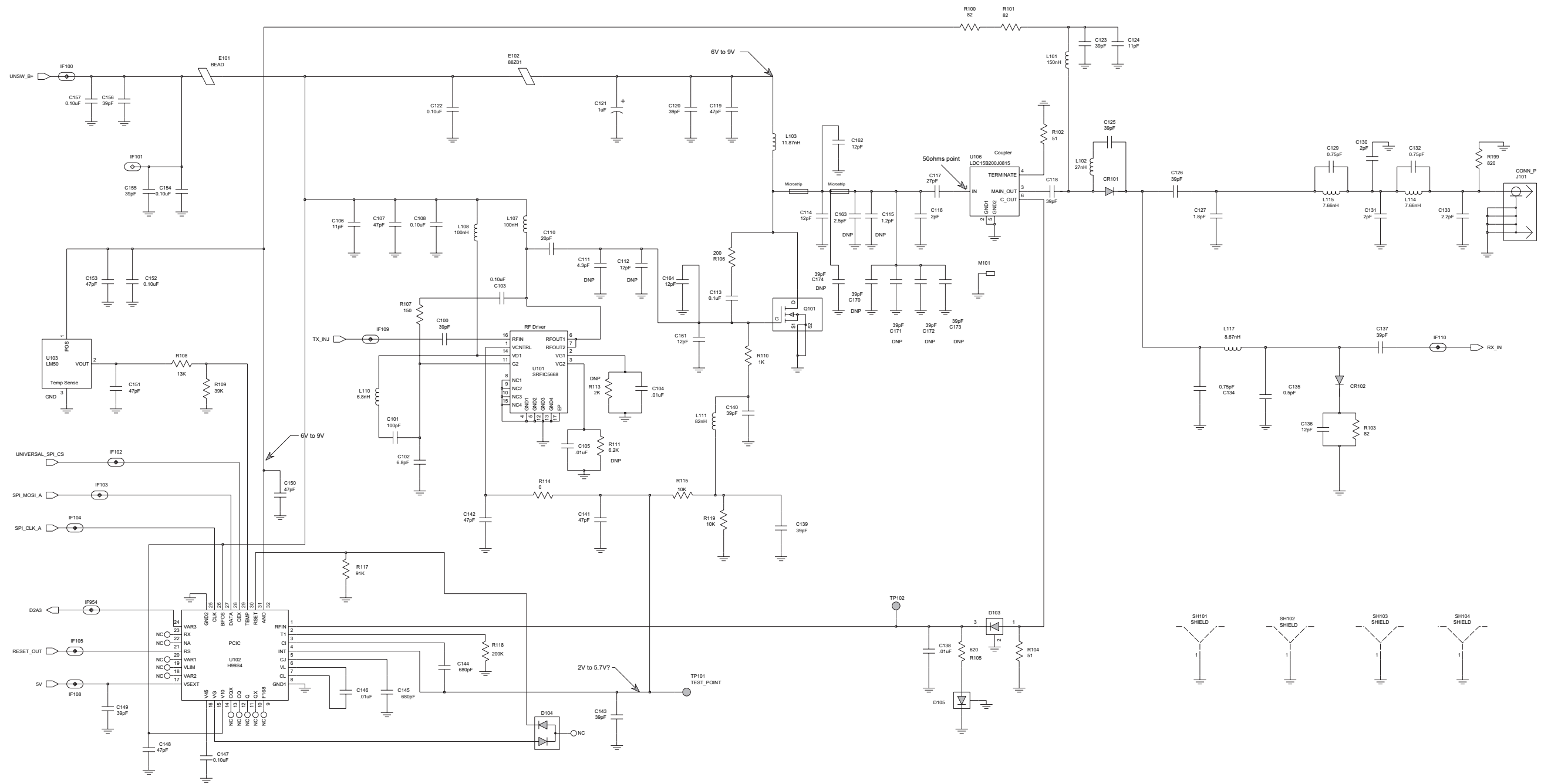

Figure 9.5-15. Transmitter Schematic

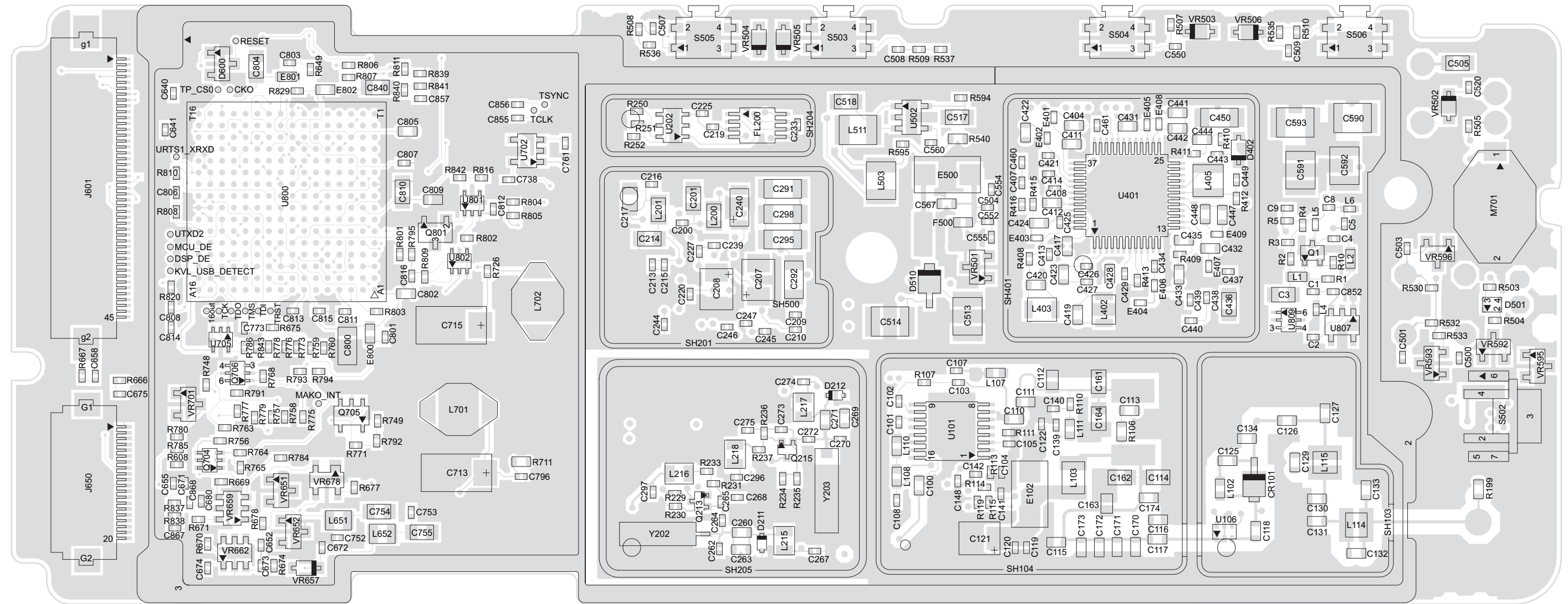

Figure 9.5-16. Main Circuit Board Component Location Detail - Side 1 (PCB No. 8416005H01-A)

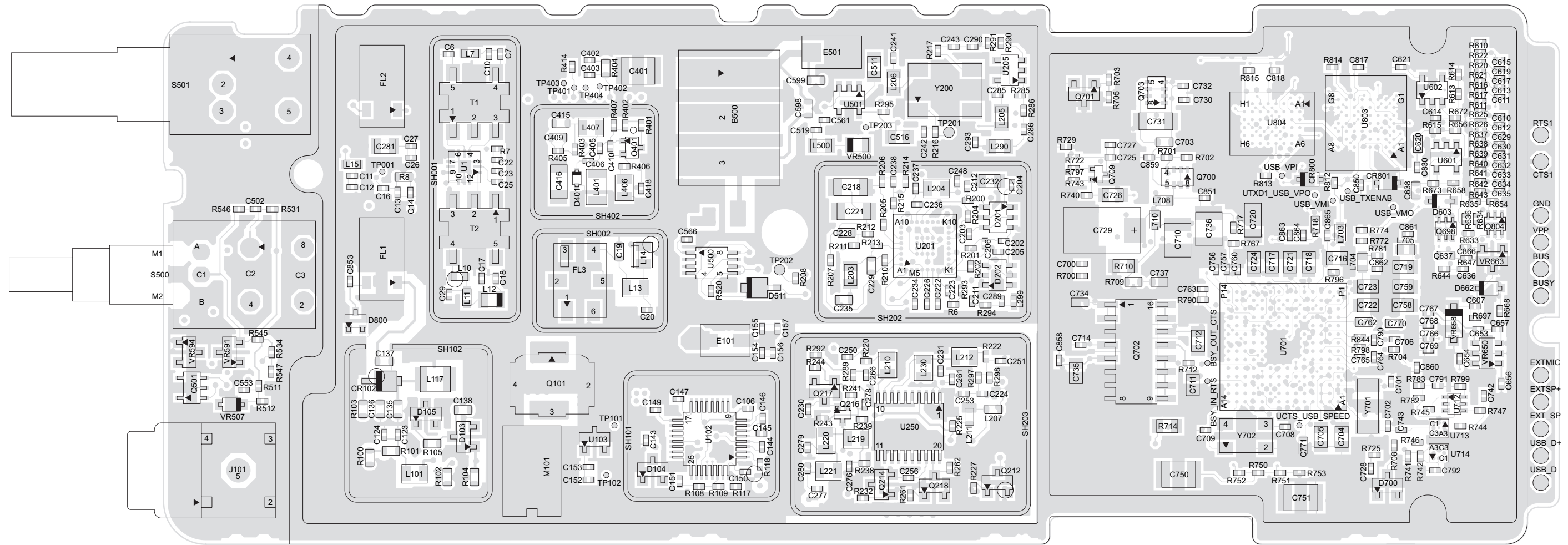

Figure 9.5-17. Main Circuit Board Component Location Detail - Side 2 (PCB No. 8416005H01-A)

8416005H01 Main Circuit Board
Electrical Parts List

ITEM	MOTOROLA PART NUMBER	DESCRIPTION
PCB	8416005H01	PC BOARD, MAIN 900MHZ
B500	0986237A02	CONNECTOR (CONTACT BATTERY)
C1	2113945Y02	CAP,FXD,.1UF,+10%,-10%, 16V-DC,0402
C2	2113944A32	CAP CER CHP 39.0PF 50V 5%
C3	2113946F03	CAP CER CHP 4.7UF 6.3V 10%
C4	2113944A42	CAP CER CHP 150.0PF 50V 5%
C5	2113944A14	CAPACITOR,CHIP,3.6PF,.25PF+/-
C6	2113944A19	CAP CER CHP 5.6PF 50V +/- 0.5PF
C7	2113944A32	CAP CER CHP 39.0PF 50V 5%
C8	2113944A32	CAP CER CHP 39.0PF 50V 5%
C9	2113944A32	CAP CER CHP 39.0PF 50V 5%
C10	0613952R66	CER CHIP RES 0.0 +/- 0.050 OHM
C11	2113945B04	CAP,FXD,.022UF,+10%,-10%,25V-DC,0402
C12	2113944A85	CAP,FXD,51PF,+5%,-5%,50V-DC
C13	NOT PLACED	
C14	NOT PLACED	
C16	2113944A33	CAP CER CHP 47.0PF 50V 5%

ITEM	MOTOROLA PART NUMBER	DESCRIPTION
C17	2113944A08	CAP CER CHP 2.0PF 50V +/- 0.25PF
C18	2113944A01	CAP CER CHP 1.1PF 50V +/- 0.25PF
C19	2113944C67	CAP,FXD,1.5PF,.1PF+/-,50V-DC,0603
C20	2113944A09	CAP CER CHP 2.2PF 50V +/- 0.25PF
C22	2113944A32	CAP CER CHP 39.0PF 50V 5%
C23	2113945B04	CAP,FXD,.022UF,+10%,-10%,25V-DC,0403
C25	2113945B04	CAP,FXD,.022UF,+10%,-10%,25V-DC,0404
C26	2113944A32	CAP CER CHP 39.0PF 50V 5%
C27	2113945B04	CAP,FXD,.022UF,+10%,-10%,25V-DC,0405
C28	2313960M51	CAP,FXD,10UF,+10%,-10%,6.3V-DC
C29	2113944A36	CAP CER CHP 68.0PF 50V 5%
C100	2113944C37	CAP CER CHP 39.0PF 50V 5%
C101	2113944A40	CAP CER CHP 100.0PF 50V 5%
C102	2113944A21	CAP CER CHP 6.8PF 50V +/- 0.5PF
C103	2113945Y02	CAP,FXD,.1UF,+10%,-10%,16V-DC,0402
C104	2113945B02	CAP CER CHP 10,000PF 25V 10%
C105	2113945B02	CAP CER CHP 10,000PF 25V 10%

ITEM	MOTOROLA PART NUMBER	DESCRIPTION
C106	2113944A77	CAP,FXD,11PF,+5%,-5%,50V-DC,0402,C
C107	2113944A33	CAP CER CHP 47.0PF 50V 5%
C108	2113945Y02	CAP,FXD,.1UF,+10%,-10%,16V-DC,0402
C110	2113944M25	CAP,FXD,20PF,+2%,-2%,50V-DC,0603,C
C111	NOT PLACED	
C112	NOT PLACED	
C113	2113945C31	CAP,FXD,.1UF,+10%,-10%,50V-DC,0602
C114	2113951D37	CAP,FXD,15PF,+1%,-1%,250V-DC,0805
C115	NOT PLACED	
C116	2113951C16	CAP,FXD,1.8PF,.05PF+/-,250V-DC,0603
C117	2113944M28	CAP,FXD,27PF,+2%,-2%,50V-DC,0603
C118	2113944C37	CAP CER CHP 39.0PF 50V 5%
C119	2113944A33	CAP CER CHP 47.0PF 50V 5%
C120	2113944A32	CAP CER CHP 39.0PF 50V 5%
C121	2313960C26	CAP TANT 1.0 UF 10% 35V
C122	2113945Y02	CAP,FXD,.1UF,+10%,-10%,16V-DC,0402
C123	2113944A32	CAP CER CHP 39.0PF 50V 5%
C124	2113944A77	CAP,FXD,11PF,+5%,-5%,50V-DC,0402,C

ITEM	MOTOROLA PART NUMBER	DESCRIPTION
C125	2113944C37	CAP CER CHP 39.0PF 50V 5%
C126	2113944C37	CAP CER CHP 39.0PF 50V 5%
C127	2113944C69	CAP,FXD,1.8PF,.1PF+/-
C129	2113944C62	CAP,FXD,.75PF,.1PF+/-,50V-DC,0603
C130	2113944M01	CAP,FXD,2PF,.1PF+/-,50V-DC,0603
C131	2113944M01	CAP,FXD,2PF,.1PF+/-,50V-DC,0603
C132	2113944C62	CAP,FXD,.75PF,.1PF+/-,50V-DC,0603
C133	2113944M02	CAP,FXD,2.2PF,.1PF+/-,50V-DC,0603
C134	2113944C62	CAP,FXD,.75PF,.1PF+/-,50V-DC,0603
C135	2113944C61	CAP,FXD,.5PF,.1PF+/-,50V-DC
C136	2113944C31	CAP CER CHP 12.0PF 50V 5%
C137	2113944C37	CAP CER CHP 39.0PF 50V 5%
C138	2113945L49	CAP,FXD,.01UF,+5%,-5%,50V-DC,0603
C139	2113944A32	CAP CER CHP 39.0PF 50V 5%
C140	2113944A32	CAP CER CHP 39.0PF 50V 5%
C141	2113944A33	CAP CER CHP 47.0PF 50V 5%
C142	2113944A33	CAP CER CHP 47.0PF 50V 5%
C143	2113944A32	CAP CER CHP 39.0PF 50V 5%

ITEM	MOTOROLA PART NUMBER	DESCRIPTION
C144	2113945A07	CAP CER CHP 680PF 50V 10%
C145	2113945A07	CAP CER CHP 680PF 50V 10%
C146	2113945B02	CAP CER CHP 10,000PF 25V 10%
C147	2113945Y02	CAP,FXD,.1UF,+10%, -10%,16V-DC,0402
C148	2113944A33	CAP CER CHP 47.0PF 50V 5%
C149	2113944A32	CAP CER CHP 39.0PF 50V 5%
C150	2113944A33	CAP CER CHP 47.0PF 50V 5%
C151	2113944A33	CAP CER CHP 47.0PF 50V 5%
C152	2113945Y02	CAP,FXD,.1UF,+10%, -10%,16V-DC,0402
C153	2113944A33	CAP CER CHP 47.0PF 50V 5%
C154	2113945Y02	CAP,FXD,.1UF,+10%, -10%,16V-DC,0402
C155	2113944A32	CAP CER CHP 39.0PF 50V 5%
C156	2113944A32	CAP CER CHP 39.0PF 50V 5%
C157	2113945Y02	CAP,FXD,.1UF,+10%, -10%,16V-DC,0402
C161	2113944F44	CAP,FXD,12PF,+5%, -5%,50V-DC,0805,
C162	2113951D36	CAP,FXD,12PF,+1%, -1%,250V-DC,0805
C163	NOT PLACED	
C164	2113944F44	CAP,FXD,12PF,+5%, -5%,50V-DC,0805,

ITEM	MOTOROLA PART NUMBER	DESCRIPTION
C170	NOT PLACED	
C171	NOT PLACED	
C172	NOT PLACED	
C173	NOT PLACED	
C174	NOT PLACED	
C200	2113945Y02	CAP,FXD,.1UF,+10%, -10%,16V-DC,0402
C201	2113955C33	CAP,FXD,2.2UF,+10%, -10%,16V-DC,0805,X7R
C202	2113945B02	CAP CER CHP 10,000PF 25V 10%
C203	2113945B02	CAP CER CHP 10,000PF 25V 10%
C204	2113945B02	CAP CER CHP 10,000PF 25V 10%
C205	2113945B02	CAP CER CHP 10,000PF 25V 10%
C206	2113944A31	CAP CER CHP 33.0PF 50V 5%
C207	2313960D07	CAP,FXD,10,+/-10%
C208	2313960D07	CAP,FXD,10,+/-10%
C209	2113945Y02	CAP,FXD,.1UF,+10%, -10%,16V-DC,0402
C210	2113944A32	CAP CER CHP 39.0PF 50V 5%
C211	NOT PLACED	
C212	2113945Y02	CAP,FXD,.1UF,+10%, -10%,16V-DC,0402
C213	2113945B02	CAP CER CHP 10,000PF 25V 10%
C214	2113955C33	CAP,FXD,2.2UF,+10%, -10%,16V-DC,0805,X7R

ITEM	MOTOROLA PART NUMBER	DESCRIPTION
C215	2113945Y02	CAP,FXD,.1UF,+10%, -10%,16V-DC,0402
C216	2113944A32	CAP CER CHP 39.0PF 50V 5%
C217	2113955C33	CAP,FXD,2.2UF,+10%, -10%,16V-DC,0805,X7R
C218	2185419D06	CAP,CHIP,.1UF,+10%, -10%,25V-DC
C219	2113945Y02	CAP,FXD,.1UF,+10%, -10%,16V-DC,0402
C220	2113944A32	CAP CER CHP 39.0PF 50V 5%
C221	2185419D06	CAP,CHIP,.1UF,+10%, -10%,25V-DC
C222	2113944A32	CAP CER CHP 39.0PF 50V 5%
C223	2113945A01	CAP CER CHP 220PF 50V 10%
C224	2113945Y02	CAP,FXD,.1UF,+10%, -10%,16V-DC,0402
C225	2113945Y02	CAP,FXD,.1UF,+10%, -10%,16V-DC,0402
C226	2113944A32	CAP CER CHP 39.0PF 50V 5%
C227	2113945Y02	CAP,FXD,.1UF,+10%, -10%,16V-DC,0402
C228	2113945C03	CAP CER CHP 15,000PF 50V 10%
C229	2113945C03	CAP CER CHP 15,000PF 50V 10%
C230	2113944A32	CAP CER CHP 39.0PF 50V 5%
C231	NOT PLACED	
C232	2113955C33	CAP,FXD,2.2UF,+10%, -10%,16V-DC,0805,X7R

ITEM	MOTOROLA PART NUMBER	DESCRIPTION
C233	2113945Y02	CAP,FXD,.1UF,+10%, -10%,16V-DC,0402
C234	2113944A32	CAP CER CHP 39.0PF 50V 5%
C235	2113945L41	CAPACITOR,FIXED,4700PF +/- 5% 0603
C236	2113944A32	CAP CER CHP 39.0PF 50V 5%
C237	2113944A62	CAP,FXD,.75PF,.25PF+/- ,50V-DC
C238	2113944A32	CAP CER CHP 39.0PF 50V 5%
C239	2113945B02	CAP CER CHP 10,000PF 25V 10%
C240	2313960B57	CAP,TANTALUM,10UF, +10%,-10%,4V-DC,S
C241	2113945Y02	CAP,FXD,.1UF,+10%, -10%,16V-DC,0402
C242	2113944A32	CAP CER CHP 39.0PF 50V 5%
C243	2113945B02	CAP CER CHP 10,000PF 25V 10%
C244	2113945B02	CAP CER CHP 10,000PF 25V 10%
C245	2113945B02	CAP CER CHP 10,000PF 25V 10%
C246	2113945B02	CAP CER CHP 10,000PF 25V 10%
C247	2113945B02	CAP CER CHP 10,000PF 25V 10%
C248	2113944A13	CAP CER CHP 3.3PF 50V +/- 0.25PF
C250	2113944A32	CAP CER CHP 39.0PF 50V 5%

ITEM	MOTOROLA PART NUMBER	DESCRIPTION
C251	2113944A32	CAP CER CHP 39.0PF 50V 5%
C253	2113944A32	CAP CER CHP 39.0PF 50V 5%
C256	2113944A32	CAP CER CHP 39.0PF 50V 5%
C260	NOT PLACED	
C261	2113944A32	CAP CER CHP 39.0PF 50V 5%
C262	2114036E93	CAP,FXD,1PF,.05PF+/-,25V-DC,C0G
C263	2113951C25	CAP,FXD,4.3PF,.05PF+/-,250V-DC,0603
C264	2113944A10	CAP CER CHP 2.4PF 50V +/- 0.25PF
C265	2188881Y12	CAPACITOR,CERAMIC CHIP,1.8PF,.1PF+/-,16V-DC
C266	2113944A32	CAP CER CHP 39.0PF 50V 5%
C267	2113944A32	CAP CER CHP 39.0PF 50V 5%
C268	2113944V11	CAP,FXD,2.2PF,.1PF+/-,50V-DC,0402
C269	2113944M02	CAP,FXD,2.2PF,.1PF+/-,50V-DC,0603
C270	2114036E93	CAP,FXD,1PF,.05PF+/-,25V-DC,C0G
C271	2113944M03	CAP CER CHIP 2.4PF +-0.1PF
C272	2113944V11	CAP,FXD,2.2PF,.1PF+/-,50V-DC,0402
C273	2188881Y12	CAPACITOR,CERAMIC CHIP,1.8PF,.1PF+/-,16V-DC

ITEM	MOTOROLA PART NUMBER	DESCRIPTION
C274	2113944A32	CAP CER CHP 39.0PF 50V 5%
C275	2188881Y12	CAPACITOR,CERAMIC CHIP,1.8PF,.1PF+/-,16V-DC
C276	2113944A32	CAP CER CHP 39.0PF 50V 5%
C277	2113944A32	CAP CER CHP 39.0PF 50V 5%
C278	2113944A32	CAP CER CHP 39.0PF 50V 5%
C279	2113944A05	CAP CER CHP 1.5PF 50V +/- 0.25PF
C280	2113944A08	CAP CER CHP 2.0PF 50V +/- 0.25PF
C285	2113945Y02	CAP,FXD,.1UF,+10%,-10%,16V-DC,0402
C286	2113945A09	CAP CER CHP 1000PF 50V 10%
C289	2113945Y02	CAP,FXD,.1UF,+10%,-10%,16V-DC,0402
C290	2113945A09	CAP CER CHP 1000PF 50V 10%
C291	2185419D06	CAP,CHIP,.1UF,+10%,-10%,25V-DC
C292	2185419D06	CAP,CHIP,.1UF,+10%,-10%,25V-DC
C293	2113944A40	CAP CER CHP 100.0PF 50V 5%
C295	2185419D06	CAP,CHIP,.1UF,+10%,-10%,25V-DC
C296	2113944A32	CAP CER CHP 39.0PF 50V 5%
C297	2113944A32	CAP CER CHP 39.0PF 50V 5%

ITEM	MOTOROLA PART NUMBER	DESCRIPTION
C298	2185419D06	CAP,CHIP,.1UF,+10%,-10%,25V-DC
C401	2113955E37	CAPACITOR,FIXED,10UF,+10%,-10%,16V-DC,1210
C402	2113945Y02	CAP,FXD,.1UF,+10%,-10%,16V-DC,0402
C403	2113945Y02	CAP,FXD,.1UF,+10%,-10%,16V-DC,0402
C404	2113944C37	CAP CER CHP 39.0PF 50V 5%
C405	2113944A79	CAP,FXD,16PF,+5%,-5%,50V-DC
C406	2113944A79	CAP,FXD,16PF,+5%,-5%,50V-DC
C407	2113944A25	CAP CER CHP 10.0PF 50V +/- 0.5PF
C408	2113945B02	CAP CER CHP 10,000PF 25V 10%
C409	2113945L49	CAP,FXD,.01UF,+5%,-5%,50V-DC,0604
C410	2113944A32	CAP CER CHP 39.0PF 50V 5%
C411	2113945C31	CAP,FXD,.1UF,+10%,-10%,50V-DC,0603
C412	2113945C31	CAP,FXD,.1UF,+10%,-10%,50V-DC,0603
C413	2113945B02	CAP CER CHP 10,000PF 25V 10%
C414	2113945B02	CAP CER CHP 10,000PF 25V 10%
C415	2113945L37	CAP,FXD,3300PF,+5%,-5%,50V-DC,0603
C416	2189705V01	CAP,CER,.1UF,+5%,-5%,50V-DC

ITEM	MOTOROLA PART NUMBER	DESCRIPTION
C417	2113945C31	CAP,FXD,.1UF,+10%,-10%,50V-DC,0603
C418	2113944A32	CAP CER CHP 39.0PF 50V 5%
C419	NOT PLACED	
C420	NOT PLACED	
C421	2113945B02	CAP CER CHP 10,000PF 25V 10%
C422	2113945C31	CAP,FXD,.1UF,+10%,-10%,50V-DC,0603
C423	2113944C01	CAP CER CHP 180.0PF 50V 5%
C424	2113945C31	CAP,FXD,.1UF,+10%,-10%,50V-DC,0603
C425	2113945B02	CAP CER CHP 10,000PF 25V 10%
C426	2113944A40	CAP CER CHP 100.0PF 50V 5%
C427	2113944A40	CAP CER CHP 100.0PF 50V 5%
C428	2113945C31	CAP,FXD,.1UF,+10%,-10%,50V-DC,0603
C429	2113945A11	CAP CER CHP 2200PF 50V 10%
C431	2113945C31	CAP,FXD,.1UF,+10%,-10%,50V-DC,0603
C432	2113945C31	CAP,FXD,.1UF,+10%,-10%,50V-DC,0603
C433	2113945C31	CAP,FXD,.1UF,+10%,-10%,50V-DC,0603
C434	2113945B02	CAP CER CHP 10,000PF 25V 10%
C435	NOT PLACED	
C436	NOT PLACED	

ITEM	MOTOROLA PART NUMBER	DESCRIPTION
C437	2113945B02	CAP CER CHP 10,000PF 25V 10%
C438	2113945B02	CAP CER CHP 10,000PF 25V 10%
C439	2113944A40	CAP CER CHP 100.0PF 50V 5%
C440	2113944A40	CAP CER CHP 100.0PF 50V 5%
C441	2113945C31	CAP,FXD,.1UF,+10%,-10%,50V-DC,0603
C442	2113945C31	CAP,FXD,.1UF,+10%,-10%,50V-DC,0603
C443	2113944A85	CAP,FXD,51PF,+5%,-5%,50V-DC
C444	2113945C31	CAP,FXD,.1UF,+10%,-10%,50V-DC,0603
C447	2113945C31	CAP,FXD,.1UF,+10%,-10%,50V-DC,0603
C448	2113945C31	CAP,FXD,.1UF,+10%,-10%,50V-DC,0603
C449	2113945B02	CAP CER CHP 10,000PF 25V 10%
C450	2113946G04	CAP,FXD,.68UF,+10%,-10%,16V-DC,1206
C460	NOT PLACED	
C461	2113945B02	CAP CER CHP 10,000PF 25V 10%
C500	2113944A32	CAP CER CHP 39.0PF 50V 5%
C501	2113944A32	CAP CER CHP 39.0PF 50V 5%
C502	2113944A32	CAP CER CHP 39.0PF 50V 5%
C503	2113944A32	CAP CER CHP 39.0PF 50V 5%

ITEM	MOTOROLA PART NUMBER	DESCRIPTION
C504	2113945A11	CAP CER CHP 2200PF 50V 10%
C505	2113945G98	CAP,FXD,.47UF,+10%,-10%,50V-DC,0805
C507	2113945B02	CAP CER CHP 10,000PF 25V 10%
C508	2113945B02	CAP CER CHP 10,000PF 25V 10%
C509	2113945B02	CAP CER CHP 10,000PF 25V 10%
C511	2113946F03	CAP CER CHP 4.7UF 6.3V 10%
C513	2113955E37	CAPACITOR,FIXED,10UF,+10%,-10%,16V-DC,1211
C514	2113955E37	CAPACITOR,FIXED,10UF,+10%,-10%,16V-DC,1212
C516	2113946F03	CAP CER CHP 4.7UF 6.3V 10%
C517	2113946F03	CAP CER CHP 4.7UF 6.3V 10%
C518	2113946F03	CAP CER CHP 4.7UF 6.3V 10%
C519	2113944A40	CAP CER CHP 100.0PF 50V 5%
C520	2113944A32	CAP CER CHP 39.0PF 50V 5%
C550	2113945B02	CAP CER CHP 10,000PF 25V 10%
C552	2113945A01	CAP CER CHP 220PF 50V 10%
C553	2113945B02	CAP CER CHP 10,000PF 25V 10%
C554	2113945A11	CAP CER CHP 2200PF 50V 10%

ITEM	MOTOROLA PART NUMBER	DESCRIPTION
C555	2113945A01	CAP CER CHP 220PF 50V 10%
C560	2113945B02	CAP CER CHP 10,000PF 25V 10%
C561	2113945B02	CAP CER CHP 10,000PF 25V 10%
C566	2113945B02	CAP CER CHP 10,000PF 25V 10%
C567	NOT PLACED	
C590	NOT PLACED	
C591	NOT PLACED	
C592	NOT PLACED	
C593	2113955E37	CAPACITOR,FIXED,10UF,+10%,-10%,16V-DC,1214
C598	NOT PLACED	
C599	NOT PLACED	
C607	2113945Y02	CAP,FXD,.1UF,+10%,-10%,16V-DC,0402
C610	2113944A32	CAP CER CHP 39.0PF 50V 5%
C611	2113944A32	CAP CER CHP 39.0PF 50V 5%
C612	2113944A32	CAP CER CHP 39.0PF 50V 5%
C613	2113944A32	CAP CER CHP 39.0PF 50V 5%
C614	2113945A03	CAP CER CHP 330PF 50V 10%
C615	2113944A32	CAP CER CHP 39.0PF 50V 5%
C617	2113944A32	CAP CER CHP 39.0PF 50V 5%

ITEM	MOTOROLA PART NUMBER	DESCRIPTION
C619	2113944A32	CAP CER CHP 39.0PF 50V 5%
C620	2113945C31	CAP,FXD,.1UF,+10%,-10%,50V-DC,0603
C621	2113945Y02	CAP,FXD,.1UF,+10%,-10%,16V-DC,0402
C629	2113944A32	CAP CER CHP 39.0PF 50V 5%
C630	2113944A32	CAP CER CHP 39.0PF 50V 5%
C631	2113944A32	CAP CER CHP 39.0PF 50V 5%
C632	2113944A32	CAP CER CHP 39.0PF 50V 5%
C633	2113944A32	CAP CER CHP 39.0PF 50V 5%
C634	2113944A32	CAP CER CHP 39.0PF 50V 5%
C635	2113944A32	CAP CER CHP 39.0PF 50V 5%
C636	2113944A32	CAP CER CHP 39.0PF 50V 5%
C637	2113945L49	CAP,FXD,.01UF,+5%,-5%,50V-DC,0605
C638	2113945C31	CAP,FXD,.1UF,+10%,-10%,50V-DC,0603
C640	NOT PLACED	
C641	NOT PLACED	
C652	2113944A32	CAP CER CHP 39.0PF 50V 5%
C653	2113944A32	CAP CER CHP 39.0PF 50V 5%
C654	2113944A32	CAP CER CHP 39.0PF 50V 5%

ITEM	MOTOROLA PART NUMBER	DESCRIPTION
C655	2113944A32	CAP CER CHP 39.0PF 50V 5%
C656	2113944A32	CAP CER CHP 39.0PF 50V 5%
C657	2113944A32	CAP CER CHP 39.0PF 50V 5%
C658	2113944A32	CAP CER CHP 39.0PF 50V 5%
C671	2113944A31	CAP CER CHP 33.0PF 50V 5%
C672	2113944A32	CAP CER CHP 39.0PF 50V 5%
C673	2113944A31	CAP CER CHP 33.0PF 50V 5%
C674	2113945A05	CAP CER CHP 470PF 50V 10%
C675	2113944A32	CAP CER CHP 39.0PF 50V 5%
C680	2113944A31	CAP CER CHP 33.0PF 50V 5%
C700	2113946B04	CAP CER CHP 0.10UF 10V 10%
C701	2113944A19	CAP CER CHP 5.6PF 50V +/- 0.5PF
C702	2113944A19	CAP CER CHP 5.6PF 50V +/- 0.5PF
C703	NOT PLACED	
C704	2113946F01	CAP CER CHP 2.2UF 6.3V 10%
C705	2113946F01	CAP CER CHP 2.2UF 6.3V 10%
C706	2113945A09	CAP CER CHP 1000PF 50V 10%
C708	2113944A31	CAP CER CHP 33.0PF 50V 5%

ITEM	MOTOROLA PART NUMBER	DESCRIPTION
C709	2113944A31	CAP CER CHP 33.0PF 50V 5%
C710	2113946J03	CAP CER CHP 10.0UF 16V 10%
C711	2113946E02	CAP CER CHP 1.0UF 16V 10%
C712	2113946E02	CAP CER CHP 1.0UF 16V 10%
C713	2314030F03	CAP,FXD,22UF,+10%, -10%,16V
C714	2113945A09	CAP CER CHP 1000PF 50V 10%
C715	2314030F03	CAP,FXD,22UF,+10%, -10%,16V
C716	2113946F01	CAP CER CHP 2.2UF 6.3V 10%
C717	2113946E02	CAP CER CHP 1.0UF 16V 10%
C718	2113946F01	CAP CER CHP 2.2UF 6.3V 10%
C719	2113946E02	CAP CER CHP 1.0UF 16V 10%
C720	2113946G01	CAP CER CHP 2.2UF 16V 10%
C721	2113946E02	CAP CER CHP 1.0UF 16V 10%
C722	2113946E02	CAP CER CHP 1.0UF 16V 10%
C723	2113946E02	CAP CER CHP 1.0UF 16V 10%
C724	2113946E02	CAP CER CHP 1.0UF 16V 10%
C725	2113945Y02	CAP,FXD,.1UF,+10%, -10%,16V-DC,0402

ITEM	MOTOROLA PART NUMBER	DESCRIPTION
C726	2113944F07	CAP,CHIP,1000PF,+5%, -5%,50V-DC,0805
C727	2113944A31	CAP CER CHP 33.0PF 50V 5%
C728	2113944A32	CAP CER CHP 39.0PF 50V 5%
C729	2314030V06	CAP,FXD,68UF,+10%, -10%,16V-DC,SM
C730	2113944A31	CAP CER CHP 33.0PF 50V 5%
C731	2113946G01	CAP CER CHP 2.2UF 16V 10%
C732	2113944A31	CAP CER CHP 33.0PF 50V 5%
C734	2113945C31	CAP,FXD,.1UF,+10%, -10%,50V-DC,0603
C735	2113946E02	CAP CER CHP 1.0UF 16V 10%
C736	2113946J03	CAP CER CHP 10.0UF 16V 10%
C737	2113945C31	CAP,FXD,.1UF,+10%, -10%,50V-DC,0603
C738	2113945Y02	CAP,FXD,.1UF,+10%, -10%,16V-DC,0402
C742	2113945A05	CAP CER CHP 470PF 50V 10%
C743	2113944A25	CAP CER CHP 10.0PF 50V +/- 0.5PF
C750	2113946J03	CAP CER CHP 10.0UF 16V 10%
C751	2113946J03	CAP CER CHP 10.0UF 16V 10%
C752	2113944A31	CAP CER CHP 33.0PF 50V 5%

ITEM	MOTOROLA PART NUMBER	DESCRIPTION
C753	2113944A31	CAP CER CHP 33.0PF 50V 5%
C754	2113946E02	CAP CER CHP 1.0UF 16V 10%
C755	2113946E02	CAP CER CHP 1.0UF 16V 10%
C756	2113944A31	CAP CER CHP 33.0PF 50V 5%
C757	2113944A31	CAP CER CHP 33.0PF 50V 5%
C758	2113946E02	CAP CER CHP 1.0UF 16V 10%
C759	2113946E02	CAP CER CHP 1.0UF 16V 10%
C760	2113944A31	CAP CER CHP 33.0PF 50V 5%
C761	2113944A31	CAP CER CHP 33.0PF 50V 5%
C762	2113945C31	CAP,FXD,.1UF,+10%, -10%,50V-DC,0603
C763	2113944A31	CAP CER CHP 33.0PF 50V 5%
C764	2113946B03	CAP CER CHP 0.068UF 10V 10
C765	2113946B03	CAP CER CHP 0.068UF 10V 10
C766	2113944A31	CAP CER CHP 33.0PF 50V 5%
C767	2113944A31	CAP CER CHP 33.0PF 50V 5%
C768	2113944A31	CAP CER CHP 33.0PF 50V 5%
C769	2113944A31	CAP CER CHP 33.0PF 50V 5%

ITEM	MOTOROLA PART NUMBER	DESCRIPTION
C770	2113945C31	CAP,FXD,.1UF,+10%, -10%,50V-DC,0603
C771	2113945C31	CAP,FXD,.1UF,+10%, -10%,50V-DC,0603
C773	2113945Y02	CAP,FXD,.1UF,+10%, -10%,16V-DC,0402
C790	2113946A02	CAP CER CHP 0.022UF 16V 10
C791	2113945Y02	CAP,FXD,.1UF,+10% ,-10%,16V-DC,0402
C792	2113945Y02	CAP,FXD,.1UF,+10%, -10%,16V-DC,0402
C796	2113944A31	CAP CER CHP 33.0PF 50V 5%
C800	2113955D31	CAP,FXD,1UF,+10%, -10%,16V-DC,1206
C801	2113944A32	CAP CER CHP 39.0PF 50V 5%
C802	2113945C20	CAP,FXD,.016UF,+10%, -10%,50V-DC,0603
C803	2113944A32	CAP CER CHP 39.0PF 50V 5%
C804	2113946E02	CAP CER CHP 1.0UF 16V 10%
C805	2113945C20	CAP,FXD,.016UF,+10%, -10%,50V-DC,0604
C806	2113945Y02	CAP,FXD,.1UF,+10%, -10%,16V-DC,0402
C807	2113945Y02	CAP,FXD,.1UF,+10%, -10%,16V-DC,0402
C808	2113945Y02	CAP,FXD,.1UF,+10%, -10%,16V-DC,0402
C809	2113945C20	CAP,FXD,.016UF,+10%, -10%,50V-DC,0605

ITEM	MOTOROLA PART NUMBER	DESCRIPTION
C810	2113946E02	CAP CER CHP 1.0UF 16V 10%
C811	2113945Y02	CAP,FXD,.1UF,+10%, -10%,16V-DC,0402
C812	2113945Y02	CAP,FXD,.1UF,+10%, -10%,16V-DC,0402
C813	2113945Y02	CAP,FXD,.1UF,+10%, -10%,16V-DC,0402
C814	2113945Y02	CAP,FXD,.1UF,+10%, -10%,16V-DC,0402
C815	2113945Y02	CAP,FXD,.1UF,+10%, -10%,16V-DC,0402
C816	2113945Y02	CAP,FXD,.1UF,+10%, -10%,16V-DC,0402
C817	2113945Y02	CAP,FXD,.1UF,+10%, -10%,16V-DC,0402
C818	2113945Y02	CAP,FXD,.1UF,+10%, -10%,16V-DC,0402
C830	2113945Y02	CAP,FXD,.1UF,+10%, -10%,16V-DC,0402
C840	2113946F03	CAP CER CHP 4.7UF 6.3V 10%
C850	2113945A03	CAP CER CHP 330PF 50V 10%
C851	2113944A31	CAP CER CHP 33.0PF 50V 5%
C852	2113944A18	CAP CER CHP 5.1PF 50V +/- 0.5PF
C853	2113944A32	CAP CER CHP 39.0PF 50V 5%
C855	NOT PLACED	
C856	NOT PLACED	
C857	NOT PLACED	

ITEM	MOTOROLA PART NUMBER	DESCRIPTION
C858	2113945B02	CAP CER CHP 10,000PF 25V 10%
C859	2113945B02	CAP CER CHP 10,000PF 25V 10%
C860	2113945B02	CAP CER CHP 10,000PF 25V 10%
C861	2113945B02	CAP CER CHP 10,000PF 25V 10%
C862	2113945B02	CAP CER CHP 10,000PF 25V 10%
C863	2113945B02	CAP CER CHP 10,000PF 25V 10%
C864	2113945B02	CAP CER CHP 10,000PF 25V 10%
C865	2113945B02	CAP CER CHP 10,000PF 25V 10%
C866	2113945B02	CAP CER CHP 10,000PF 25V 10%
C867	NOT PLACED	
C868	NOT PLACED	
CR101	4815897H01	PIN DIODE
CR102	4815897H01	PIN DIODE
CR800	4813978A25	SCHOTTKY 30V SOD-323 T&R PB FREE
CR801	4813978A25	SCHOTTKY 30V SOD-323 T&R PB FREE
D103	4813974A05	DIODE,SWG,MMBD301,S M,SOT- 23,30V,.2W,SHTK,PB- FREE
D104	4816487H01	SWITCHING DIODE, MINIBLOC
D105	4813974A05	DIODE,SWG,MMBD301,S M,SOT-23,30V,.2W,SHTK, PB-FREE

ITEM	MOTOROLA PART NUMBER	DESCRIPTION
D201	4815011H01	DIODE TRIPLE
D202	4815011H01	DIODE TRIPLE
D211	4805656W87	DIODE,VCTR, @ 15V,1SV279,SOD-523/SC- 79
D212	4805656W87	DIODE,VCTR, @ 15V,1SV279,SOD-523/SC- 79
D401	4815096H01	VARACTOR DIODE 1SV305
D402	4885055Y01	DIODE VARACTOR PB-FREE
D501	4809118D02	LED BICOLOR LNJ115W8POMT
D510	NOT PLACED	
D511	4813978M15	DIODE,RECT,RM140,SM, 1A,40V,SHTK,PB-FREE
D600	4813978B18	DIODE,SWG,BAT54,SM, SOT-23,200MA,30V,.2W, SHTK,PB-FREE
D603	4813978A25	SCHOTTKY 30V SOD-323 T&R PB FREE
D662	4813978A25	SCHOTTKY 30V SOD-323 T&R PB FREE
D700	4813978B18	DIODE,SWG,BAT54,SM, SOT-23,200MA,30V,.2W, SHTK,PB-FREE
D800	4813974A19	DIODE ARRAY,MXR,SM, SOT-323,7V,.2W,SHTK,2, PB-FREE
E101	2415954H02	INDUCTOR BEAD CHIP EPP WITH EPOXY
E102	2405688Z01	INDUCTOR FERRITE BEAD

ITEM	MOTOROLA PART NUMBER	DESCRIPTION
E401	2480640Z01	SURFACE MOUNT FERRITE BEAD
E402	2480640Z01	SURFACE MOUNT FERRITE BEAD
E403	2480640Z01	SURFACE MOUNT FERRITE BEAD
E404	2480640Z01	SURFACE MOUNT FERRITE BEAD
E405	2480640Z01	SURFACE MOUNT FERRITE BEAD
E406	2480640Z01	SURFACE MOUNT FERRITE BEAD
E407	2480640Z01	SURFACE MOUNT FERRITE BEAD
E408	2480640Z01	SURFACE MOUNT FERRITE BEAD
E409	2480640Z01	SURFACE MOUNT FERRITE BEAD
E500	2405688Z01	INDUCTOR FERRITE BEAD
E501	2405688Z01	INDUCTOR FERRITE BEAD
E800	2480574F01	IND FERRITE CHIP 60OHM 0603
E801	2480574F01	IND FERRITE CHIP 60OHM 0603
E802	0613952G67	CER CHIP RES 0.0 +/- 0.050 OHM
F500	6515076H01	FUSE CHIP SMT TR/ 1608FF 3A
FL1	9116138H01	CERAMIC FILTER
FL2	9116138H01	CERAMIC FILTER
FL3	4885631B01	XTAL FILT 3 POLE 109.65 MOTORO

ITEM	MOTOROLA PART NUMBER	DESCRIPTION
FL200	9116848H01	FLTR SW CAP 3 POLE BUTTERW, W18
J101	2880658Z08	CONNECTOR SMA
J601	0916287H01	CONN VERT 45 PIN ZIF
J650	0916287H02	CONN 20 PIN ZIF
L1	2414017N23	IDCTR,CHIP,82NH,5%,300 MA,1.8OHM,0603
L2	2415429H38	CHIP INDUCTOR, 120nH +/-5%
L4	2488090Y09	INDUCTOR,MULTILAYER, 4.7NH
L5	2414017P13	IDCTR,CHIP,10NH,5%,300 MA
L6	2488090Y11	INDUCTOR,MULTILAYER, 6.8NH
L7	2414017N14	IDCTR,CHIP,15NH,5%
L10	2415429H32	CHIP INDUCTOR, 56nH +/-5%
L11	2414017N22	IDCTR,CHIP,68NH,5%
L12	2414017K29	IND CER CHIP 330.0 NH 5%
L13	2414032F42	IDCTR,WW,470NH,10%,17 0MA,2.5OHM,CER
L14	2414032F38	IDCTR,WW,220NH,5%
L15	2415429H43	CHIP INDUCTOR, 220nH +/-5%
L101	2414032F36	IDCTR,WW,150NH,5%
L102	2414017G12	IDCTR,CHIP,27NH,5%, 300MA,.6OHM
L103	2460591C03	COIL AIR WOUND INDUC 11.87
L107	2414017G19	IDCTR,CHIP,100NH,5%, 300MA,2.5OHM

ITEM	MOTOROLA PART NUMBER	DESCRIPTION
L108	2414017G19	IDCTR,CHIP,100NH,5%, 300MA,2.5OHM
L110	2414017G05	IDCTR,CHIP,6.8NH,5%, 300MA, 0603
L111	2414017N23	IDCTR,CHIP,82NH,5%
L114	2460591A11	COIL AIR WOUND INDUC 7.66
L115	2460591A11	COIL AIR WOUND INDUC 7.66
L117	2460591B22	COIL AIR WOUND INDUC 8.67
L200	2414017Q20	IDCTR,FXD,2.2UH,20%, 30MA,.65OHM,FER
L201	2414017Q20	IDCTR,FXD,2.2UH,20%, 30MA,.65OHM,FER
L203	2414017Q47	IDCTR,FXD,1UH,10%,50M A,.45OHM,FERR
L204	2414032F21	IDCTR,WW,6.8NH,5%, 600MA,.11OHM,CER
L205	2414017Q20	IDCTR,FXD,2.2UH,20%, 30MA,.65OHM,FER
L206	2414017Q20	IDCTR,FXD,2.2UH,20%, 30MA,.65OHM,FER
L207	0613952G67	CER CHIP RES 0.0 +/-0.050 OHM
L210	2414032F36	IDCTR,WW,150NH,5%
L211	0613952G67	CER CHIP RES 0.0 +/-0.050 OHM
L212	2414032F36	IDCTR,WW,150NH,5%
L215	2414032F34	IDCTR,WW,100NH,5%, 400MA,.46OHM,CER
L216	2414032F34	IDCTR,WW,100NH,5%, 400MA,.46OHM,CER

ITEM	MOTOROLA PART NUMBER	DESCRIPTION
L217	2414032F34	IDCTR,WW,100NH,5%, 400MA,.46OHM,CER
L218	2414032F34	IDCTR,WW,100NH,5%, 400MA,.46OHM,CER
L219	2414032F36	IDCTR,WW,150NH,5%
L220	2414032F27	IDCTR,WW,27NH,5%, 500MA,.25OHM,CER
L221	2414032F25	IDCTR,WW,18NH,5%, 600MA,.2OHM,CER
L230	2414032F25	IDCTR,WW,18NH,5%, 600MA,.2OHM,CER
L290	2414017Q47	IDCTR,FXD,1UH,10%, 50MA,.45OHM,FERR
L299	NOT PLACED	
L401	2414032D17	IDCTR,WW,150NH,5%, 750MA,.31OHM,CER
L402	2466505A01	COIL INDUCTOR
L403	2466505A01	COIL INDUCTOR
L405	2414032B76	IDCTR,WW,4.7UH,5%, 330MA,4OHM
L406	2414032F73	IDCTR,WW,820NH,5%, 180MA,2.23OHM,CER
L407	2414032F73	IDCTR,WW,820NH,5%, 180MA,2.23OHM,CER
L500	2414017Q42	IDCTR,FXD,390NH,10%, 200MA,.65OHM,FE
L503	2489669V01	IDCTR,WW,100UH,5%
L511	2489669V01	IDCTR,WW,100UH,5%
L651	2414032F75	IDCTR,WW,270NH,2%, 350MA,1OHM
L652	2414032F75	IDCTR,WW,270NH,2%, 350MA,1OHM
L701	2486085A01	COIL, POWER INDUCTOR

ITEM	MOTOROLA PART NUMBER	DESCRIPTION
L702	2486085A01	COIL, POWER INDUCTOR
L703	2464675H01	IDCTR,WW,560NH,5%,550MA
L704	2464675H01	IDCTR,WW,560NH,5%,550MA
L705	2464675H01	IDCTR,WW,560NH,5%,550MA
L708	2416307H01	IDCTR,WW,680NH,5%,0603
L710	2416307H01	IDCTR,WW,680NH,5%,0603
M101	3916333H01	GROUND CONTACT
M701	0985888K02	SKT RTC BTTY LEAP
Q1	4802247J01	BJT, RF AMP, BFS505
Q101	4816698H01	MOD,XSTR,FET RF PWR,7/800
Q212	4813972A15	N-Ch TMOS FET, '6Z', SOT23 T&R
Q213	4885061Y01	XSTR NPN 6V 30UA 12GHZ PB-FREE
Q214	4813972A15	N-Ch TMOS FET, '6Z', SOT23 T&R
Q215	4885061Y01	XSTR NPN 6V 30UA 12GHZ PB-FREE
Q216	4885061Y01	XSTR NPN 6V 30UA 12GHZ PB-FREE
Q217	4813972A15	N-Ch TMOS FET, '6Z', SOT23 T&R
Q218	4813972A15	N-Ch TMOS FET, '6Z', SOT23 T&R
Q401	4805585Q27	TRANSISTOR RF NPN, BFQ67W NOPB
Q501	4805921T28	XSTR, DUAL NOPB

ITEM	MOTOROLA PART NUMBER	DESCRIPTION
Q698	4813973A81	XSTR,BIP GP SS,DIG,NPN AND PNP,SOT-363,50V,.25W,100MA,BIAS
Q700	4813970A62	XSTR,FET GP PWR, MOSFET,P-CH,ENHN,CF,-20V,1.3W,PB-FREE
Q701	4813973M07	XSTR,BIP GP SS,NPN,T3904,SM,SOT-23,SMT,40V,.225W,200MA,300MH Z
Q702	5185956E76	IC,CONV,SM,SO16,0-30 VINPUT RANGE,6.5A,3.8V, HI SPD SWTH DR
Q703	4813970A62	XSTR,FET GP PWR, MOSFET,P-CH,ENHN,CF,-20V,1.3W,PB-FREE
Q704	NOT PLACED	
Q705	NOT PLACED	
Q706	NOT PLACED	
Q709	4885061Y01	XSTR NPN 6V 30UA 12GHZ PB-FREE
Q801	4813973A42	XSTR,BIP GP SS,NPN,SM, SC-59,SMT,50V,.23W,100MA,PB-FREE
Q804	4813973A81	XSTR,BIP GP SS,DIG,NPN AND PNP,SOT-363,50V,.25W,100MA,BIAS
R1	0613952Q55	CER CHIP RES 180 OHM 5 0402
R2	0613952Q96	CER CHIP RES 9100 OHM 5 0402
R3	0613952Q83	CER CHIP RES 2700 OHM 5 0401

ITEM	MOTOROLA PART NUMBER	DESCRIPTION
R4	0613952Q83	CER CHIP RES 2700 OHM 5 0402
R5	0613952Q54	CER CHIP RES 160 OHM 5 0402
R6	NOT PLACED	
R7	0613952Q39	CER CHIP RES 39.0 OHM 5 0402
R8	0613952G67	CER CHIP RES 0.0 +/-0.050 OHM
R10	0613952R66	CER CHIP RES 0.0 +/-0.050 OHM
R100	0613952H47	CER CHIP RES 82.0 OHM 5 0603
R101	0613952H47	CER CHIP RES 82.0 OHM 5 0603
R102	0613952H42	CER CHIP RES 51.0 OHM 5% 0603
R103	0613952H47	CER CHIP RES 82.0 OHM 5 0603
R104	0613952H42	CER CHIP RES 51.0 OHM 5% 0603
R105	0613952H68	CER CHIP RES 620 OHM 5 0603
R106	0613952H56	CER CHIP RES 200 OHM 5 0603
R107	0613952Q53	CER CHIP RES 150 OHM 5 0402
R108	0613952R04	CER CHIP RES 13K OHM 5 0402
R109	0613952R15	CER CHIP RES 39K OHM 5% 0402
R110	0613952Q73	CER CHIP RES 1000 OHM 5 0402
R111	NOT PLACED	

ITEM	MOTOROLA PART NUMBER	DESCRIPTION
R113	NOT PLACED	
R114	0613952R66	CER CHIP RES 0.0 +/-0.050 OHM
R115	0613952R01	CER CHIP RES 10K OHM 5% 0402
R117	0613952R24	CER CHIP RES 91K OHM 5 0402
R118	0613952R32	CER CHIP RES 200K OHM 5 0402
R119	0613952R01	CER CHIP RES 10K OHM 5% 0402
R199	0613952H71	CER CHIP RES 820 OHM 5 0603
R200	0613952Q49	CER CHIP RES 100 OHM 5 0402
R201	0613952Q53	CER CHIP RES 150 OHM 5 0402
R202	0613952Q53	CER CHIP RES 150 OHM 5 0402
R204	0613952R66	CER CHIP RES 0.0 +/-0.050 OHM
R205	0613952Q87	CER CHIP RES 3900 OHM 5 0402
R206	0613952Q48	CER CHIP RES 91.0 OHM 5 0402
R207	0613952Q56	CER CHIP RES 200 OHM 5 0402
R208	0613952Q73	CER CHIP RES 1000 OHM 5 0402
R210	0613952Q70	CER CHIP RES 750 OHM 5 0402
R211	0613952R66	CER CHIP RES 0.0 +/-0.050 OHM
R212	0613952Q61	CER CHIP RES 330 OHM 5 0402

ITEM	MOTOROLA PART NUMBER	DESCRIPTION
R213	0613952R66	CER CHIP RES 0.0 +/-0.050 OHM
R214	0613952R03	CER CHIP RES 12K OHM 5% 0402
R215	0613952R08	CER CHIP RES 20K OHM 5 0402
R216	0613952R17	CER CHIP RES 47K OHM 5% 0402
R217	0613952Q49	CER CHIP RES 100 OHM 5 0402
R220	0613952Q61	CER CHIP RES 330 OHM 5 0402
R222	0613952Q70	CER CHIP RES 750 OHM 5 0402
R225	0613952Q37	CER CHIP RES 33.0 OHM 5 0402
R227	0613952R18	CER CHIP RES 51K OHM 5 0402
R229	0613952R07	CER CHIP RES 18K OHM 5% 0402
R230	0613952R08	CER CHIP RES 20K OHM 5 0402
R231	0613952Q31	CER CHIP RES 18.0 OHM 5 0402
R232	0613952R18	CER CHIP RES 51K OHM 5 0402
R233	0613952Q57	CER CHIP RES 220 OHM 5 0402
R234	0613952R07	CER CHIP RES 18K OHM 5% 0402
R235	0613952R08	CER CHIP RES 20K OHM 5 0402
R236	0613952Q33	CER CHIP RES 22.0 OHM 5 0402

ITEM	MOTOROLA PART NUMBER	DESCRIPTION
R237	0613952Q58	CER CHIP RES 240 OHM 5 0402
R238	0613952Q53	CER CHIP RES 150 OHM 5 0402
R239	0613952R10	CER CHIP RES 24K OHM 5 0402
R241	0613952R66	CER CHIP RES 0.0 +/-0.050 OHM
R243	0613952R12	CER CHIP RES 30K OHM 5 0402
R244	0613952R18	CER CHIP RES 51K OHM 5 0402
R250	0613952R66	CER CHIP RES 0.0 +/-0.050 OHM
R251	0613952R66	CER CHIP RES 0.0 +/-0.050 OHM
R252	0613952R66	CER CHIP RES 0.0 +/-0.050 OHM
R261	0613952R18	CER CHIP RES 51K OHM 5 0402
R262	0613952Q91	CER CHIP RES 5600 OHM 5 0402
R285	0613952Q80	CER CHIP RES 2000 OHM 5 0402
R286	0613952Q45	CER CHIP RES 68.0 OHM 5 0402
R289	0613952Q47	CER CHIP RES 82.0 OHM 5% 0402
R290	0613952R13	CER CHIP RES 33K OHM 5% 0402
R291	0613952R14	CER CHIP RES 36K OHM 5 0402
R292	0613952Q37	CER CHIP RES 33.0 OHM 5 0402

ITEM	MOTOROLA PART NUMBER	DESCRIPTION
R293	0613952Q95	CER CHIP RES 8200 OHM 5 0402
R294	0613952R66	CER CHIP RES 0.0 +/-0.050 OHM
R295	0613952R17	CER CHIP RES 47K OHM 5% 0402
R297	0613952R66	CER CHIP RES 0.0 +/-0.050 OHM
R298	NOT PLACED	
R401	0613952Q49	CER CHIP RES 100 OHM 5 0402
R402	0613952R10	CER CHIP RES 24K OHM 5 0402
R403	0613952Q94	CER CHIP RES 7500 OHM 5 0402
R404	0613952C81	CER CHIP RES 681 OHM 1% 0603
R405	0613952Q80	CER CHIP RES 2000 OHM 5 0402
R406	0613952Q61	CER CHIP RES 330 OHM 5 0402
R407	0613952R10	CER CHIP RES 24K OHM 5 0402
R408	0613952Q41	CER CHIP RES 47.0 OHM 5 0402
R409	0613952R25	CER CHIP RES 100K OHM 5% 0402
R410	0613952R01	CER CHIP RES 10K OHM 5% 0402
R411	0613952Q63	CER CHIP RES 390 OHM 5 0402
R412	0613952R01	CER CHIP RES 10K OHM 5% 0402
R413	0613952R66	CER CHIP RES 0.0 +/-0.050 OHM

ITEM	MOTOROLA PART NUMBER	DESCRIPTION
R414	0613952R25	CER CHIP RES 100K OHM 5% 0402
R415	0613952R66	CER CHIP RES 0.0 +/-0.050 OHM
R416	NOT PLACED	
R503	0613952Q63	CER CHIP RES 390 OHM 5 0402
R504	0613952Q66	CER CHIP RES 510 OHM 5 0402
R505	0613952Q93	CER CHIP RES 6800 OHM 5 0402
R507	0613952Q49	CER CHIP RES 100 OHM 5 0402
R508	0613952Q49	CER CHIP RES 100 OHM 5 0402
R509	0613952Q49	CER CHIP RES 100 OHM 5 0402
R510	0613952Q49	CER CHIP RES 100 OHM 5 0402
R511	0613952R01	CER CHIP RES 10K OHM 5% 0402
R512	0613952R17	CER CHIP RES 47K OHM 5% 0402
R520	0613952R37	CER CHIP RES 330K OHM 5% 0402
R530	0613952R01	CER CHIP RES 10K OHM 5% 0402
R531	0613952R01	CER CHIP RES 10K OHM 5% 0402
R532	0613952R01	CER CHIP RES 10K OHM 5% 0402
R533	0613952R01	CER CHIP RES 10K OHM 5% 0402
R534	0613952R01	CER CHIP RES 10K OHM 5% 0402

ITEM	MOTOROLA PART NUMBER	DESCRIPTION
R535	0613952R01	CER CHIP RES 10K OHM 5% 0402
R536	0613952R01	CER CHIP RES 10K OHM 5% 0402
R537	0613952R01	CER CHIP RES 10K OHM 5% 0402
R540	NOT PLACED	
R545	0613952R17	CER CHIP RES 47K OHM 5% 0402
R546	0613952R17	CER CHIP RES 47K OHM 5% 0402
R547	0613952R17	CER CHIP RES 47K OHM 5% 0402
R594	NOT PLACED	
R595	0613952R66	CER CHIP RES 0.0 +/- 0.050 OHM
R608	0613952Q49	CER CHIP RES 100 OHM 5 0402
R610	NOT PLACED	
R611	0613952Q49	CER CHIP RES 100 OHM 5 0402
R613	0613952R08	CER CHIP RES 20K OHM 5 0402
R614	0613952R08	CER CHIP RES 20K OHM 5 0402
R615	0613952R25	CER CHIP RES 100K OHM 5% 0402
R616	0613952Q49	CER CHIP RES 100 OHM 5 0402
R617	NOT PLACED	
R620	0613952Q49	CER CHIP RES 100 OHM 5 0402
R621	0613952Q49	CER CHIP RES 100 OHM 5 0402

ITEM	MOTOROLA PART NUMBER	DESCRIPTION
R622	0613952Q49	CER CHIP RES 100 OHM 5 0402
R625	0613952Q49	CER CHIP RES 100 OHM 5 0402
R626	0613952Q49	CER CHIP RES 100 OHM 5 0402
R633	NOT PLACED	
R634	0613952R66	CER CHIP RES 0.0 +/- 0.050 OHM
R635	NOT PLACED	
R636	0613952R01	CER CHIP RES 10K OHM 5% 0402
R637	0613952Q73	CER CHIP RES 1000 OHM 5 0402
R638	0613952Q73	CER CHIP RES 1000 OHM 5 0402
R639	0613952Q73	CER CHIP RES 1000 OHM 5 0402
R640	0613952Q73	CER CHIP RES 1000 OHM 5 0402
R641	0613952Q73	CER CHIP RES 1000 OHM 5 0402
R642	0613952Q73	CER CHIP RES 1000 OHM 5 0402
R643	0613952Q73	CER CHIP RES 1000 OHM 5 0402
R644	0613952Q73	CER CHIP RES 1000 OHM 5 0402
R647	0613952R01	CER CHIP RES 10K OHM 5% 0402
R649	0613952R17	CER CHIP RES 47K OHM 5% 0402
R654	0613952R01	CER CHIP RES 10K OHM 5% 0402

ITEM	MOTOROLA PART NUMBER	DESCRIPTION
R656	0613952R01	CER CHIP RES 10K OHM 5% 0402
R658	0613952P18	CER CHIP RES 150K OHM 1 0402
R666	0613952Q57	CER CHIP RES 220 OHM 5 0402
R667	0613952Q63	CER CHIP RES 390 OHM 5 0402
R668	0613952Q45	CER CHIP RES 68.0 OHM 5 0402
R669	0613952Q49	CER CHIP RES 100 OHM 5 0402
R670	0613952Q49	CER CHIP RES 100 OHM 5 0402
R671	0613952Q63	CER CHIP RES 390 OHM 5 0402
R672	0613952R01	CER CHIP RES 10K OHM 5% 0402
R673	0613952R01	CER CHIP RES 10K OHM 5% 0402
R674	0613952Q49	CER CHIP RES 100 OHM 5 0402
R675	0613952Q67	CER CHIP RES 560 OHM 5 0402
R677	0613952R01	CER CHIP RES 10K OHM 5% 0402
R678	0613952Q49	CER CHIP RES 100 OHM 5 0402
R697	0613952Q49	CER CHIP RES 100 OHM 5 0402
R700	0613952Q80	CER CHIP RES 2000 OHM 5 0402
R701	0613952R17	CER CHIP RES 47K OHM 5% 0402

ITEM	MOTOROLA PART NUMBER	DESCRIPTION
R702	0613952R66	CER CHIP RES 0.0 +/- 0.050 OHM
R703	0613952R17	CER CHIP RES 47K OHM 5% 0402
R704	0613952Q49	CER CHIP RES 100 OHM 5 0402
R705	0613952R17	CER CHIP RES 47K OHM 5% 0402
R708	0613952R19	CER CHIP RES 56K OHM 5% 0402
R709	0613952H17	CER CHIP RES 4.7OHM 5%
R710	0688044N04	RES,METAL STRIP, 0.1 OHM,1%,0.125W,SMD,0805,75PPM/CEL,PKG
R711	0613952G67	CER CHIP RES 0.0 +/- 0.050 OHM
R712	0613952Q49	CER CHIP RES 100 OHM 5 0402
R714	0688044N04	RES,METAL STRIP, 0.1 OHM,1%,0.125W,SMD,0805,75PPM/CEL,PKG
R717	0613952R66	CER CHIP RES 0.0 +/- 0.050 OHM
R718	0613952G67	CER CHIP RES 0.0 +/- 0.050 OHM
R722	0613952R08	CER CHIP RES 20K OHM 5 0402
R725	0613952R66	CER CHIP RES 0.0 +/- 0.050 OHM
R726	0613952R66	CER CHIP RES 0.0 +/- 0.050 OHM
R729	0613952R13	CER CHIP RES 33K OHM 5% 0402

ITEM	MOTOROLA PART NUMBER	DESCRIPTION
R740	0613952Q63	CER CHIP RES 390 OHM 5 0402
R741	0613952R17	CER CHIP RES 47K OHM 5% 0402
R742	0613952R17	CER CHIP RES 47K OHM 5% 0402
R743	NOT PLACED	
R744	NOT PLACED	
R745	0613952R56	CER CHIP RES 2.0M OHM 5 0402
R746	0613952R56	CER CHIP RES 2.0M OHM 5 0402
R747	0613952Q73	CER CHIP RES 1000 OHM 5 0402
R748	0613952R41	CER CHIP RES 470K OHM 5% 0402
R749	0613952R41	CER CHIP RES 470K OHM 5% 0402
R750	0613952Q63	CER CHIP RES 390 OHM 5 0402
R751	0613952Q63	CER CHIP RES 390 OHM 5 0402
R752	0613952Q81	CER CHIP RES 2200 OHM 5 0402
R753	0613952Q81	CER CHIP RES 2200 OHM 5 0402
R756	0613952R66	CER CHIP RES 0.0 +/- 0.050 OHM
R757	0613952R08	CER CHIP RES 20K OHM 5 0402
R758	0613952R19	CER CHIP RES 56K OHM 5% 0402
R759	0613952R01	CER CHIP RES 10K OHM 5% 0402

ITEM	MOTOROLA PART NUMBER	DESCRIPTION
R760	0613952Q93	CER CHIP RES 6800 OHM 5 0402
R763	NOT PLACED	
R764	NOT PLACED	
R765	NOT PLACED	
R767	0613952R66	CER CHIP RES 0.0 +/- 0.050 OHM
R768	NOT PLACED	
R771	NOT PLACED	
R772	0613952Q49	CER CHIP RES 100 OHM 5 0402
R773	0613952Q49	CER CHIP RES 100 OHM 5 0402
R774	0613952Q49	CER CHIP RES 100 OHM 5 0402
R775	0613952Q49	CER CHIP RES 100 OHM 5 0402
R776	NOT PLACED	
R777	0613952R01	CER CHIP RES 10K OHM 5% 0402
R778	0613952R01	CER CHIP RES 10K OHM 5% 0402
R779	0613952R01	CER CHIP RES 10K OHM 5% 0402
R780	0613952Q89	CER CHIP RES 4700 OHM 5 0402
R781	0613952R01	CER CHIP RES 10K OHM 5% 0402
R782	0613952R01	CER CHIP RES 10K OHM 5% 0402
R783	0613952R01	CER CHIP RES 10K OHM 5% 0402
R784	NOT PLACED	

ITEM	MOTOROLA PART NUMBER	DESCRIPTION
R785	0613952Q49	CER CHIP RES 100 OHM 5 0402
R786	0613952R17	CER CHIP RES 47K OHM 5% 0402
R790	0613952R19	CER CHIP RES 56K OHM 5% 0402
R791	0613952R66	CER CHIP RES 0.0 +/- 0.050 OHM
R792	0613952R66	CER CHIP RES 0.0 +/- 0.050 OHM
R793	0613952R66	CER CHIP RES 0.0 +/- 0.050 OHM
R794	0613952R66	CER CHIP RES 0.0 +/- 0.050 OHM
R795	0613952R01	CER CHIP RES 10K OHM 5% 0402
R796	0613952R66	CER CHIP RES 0.0 +/- 0.050 OHM
R797	0613952Q41	CER CHIP RES 47.0 OHM 5 0402
R798	0613952Q61	CER CHIP RES 330 OHM 5 0402
R799	0613952R01	CER CHIP RES 10K OHM 5% 0402
R801	0613952Q93	CER CHIP RES 6800 OHM 5 0402
R802	0613952Q49	CER CHIP RES 100 OHM 5 0402
R803	0613952Q49	CER CHIP RES 100 OHM 5 0402
R804	0613952Q66	CER CHIP RES 510 OHM 5 0402
R805	0613952R01	CER CHIP RES 10K OHM 5% 0402

ITEM	MOTOROLA PART NUMBER	DESCRIPTION
R806	0613952Q66	CER CHIP RES 510 OHM 5 0402
R807	0613952R01	CER CHIP RES 10K OHM 5% 0402
R808	0613952R66	CER CHIP RES 0.0 +/- 0.050 OHM
R809	0613952R17	CER CHIP RES 47K OHM 5% 0402
R810	0613952R01	CER CHIP RES 10K OHM 5% 0402
R811	0613952Q66	CER CHIP RES 510 OHM 5 0402
R812	0613952R25	CER CHIP RES 100K OHM 5% 0402
R813	0613952R66	CER CHIP RES 0.0 +/- 0.050 OHM
R814	NOT PLACED	
R815	0613952R66	CER CHIP RES 0.0 +/- 0.050 OHM
R816	0613952R17	CER CHIP RES 47K OHM 5% 0402
R820	0613952R01	CER CHIP RES 10K OHM 5% 0402
R829	NOT PLACED	
R837	0613952Q37	CER CHIP RES 33.0 OHM 5 0402
R838	0613952Q37	CER CHIP RES 33.0 OHM 5 0402
R839	0613952R01	CER CHIP RES 10K OHM 5% 0402
R840	0613952Q66	CER CHIP RES 510 OHM 5 0402
R841	0613952R01	CER CHIP RES 10K OHM 5% 0402

ITEM	MOTOROLA PART NUMBER	DESCRIPTION
R842	0613952R01	CER CHIP RES 10K OHM 5% 0402
R843	0613952R41	CER CHIP RES 470K OHM 5% 0402
R844	0613952Q61	CER CHIP RES 330 OHM 5 0402
S500	4085131E04	SWITCH FREQ DUAL FUNCTION
S501	1880619Z06	POTENTIOMETER, VOLUME
S502	4016618H01	SWITCH SURFACE MOUNT
S503	4070354A01	LIGHT TOUCH SWITCH-SMD
S504	4070354A01	LIGHT TOUCH SWITCH-SMD
S505	4070354A01	LIGHT TOUCH SWITCH-SMD
S506	4070354A01	LIGHT TOUCH SWITCH-SMD
SH001	2616071H01	SHIELD MIXER
SH002	2616550H01	SHLD FITLER
SH101	2616559H01	SHLD PCIC
SH102	2616557H01	SHLD HARMONIC BOT
SH103	2616558H01	SHLD HARMONIC TOP
SH104	2616555H01	SHLD PA
SH201	2616560H01	SHLD SYN
SH202	2616556H01	SHLD FRAN N
SH203	2616553H01	SHLD VCO BOT
SH204	2616551H01	SHLD DAC
SH205	2616554H01	SHLD VCO TOP
SH401	2616552H01	SHLD ABACUS

ITEM	MOTOROLA PART NUMBER	DESCRIPTION
SH402	2616518H01	SHLD 2ND LO FLTR
SH500	NOT PLACED	
T1	2516149H01	XFMR JEDI MIXER 4:1
T2	2516372H01	TRANSFORMER, BALUN, MIXER ,25:1
U1	5164015H81	IC,MXR,DBL BAL GILBERT,CELL,SM
U101	5115678H01	VHF/UHF/800/900 MHZ LD MOS DRIVER IC
U102	5185765B26	IC PWR CTRL IN MOS20
U103	5115022H01	IC TEMPERATURE SENSOR
U106	5185368C84	DIRECTIONAL CPLR 7/800MHZ
U201	5116245H01	CC LVFRACN
U202	5185941F40	IC, 12 BIT DAC
U205	5116411H01	IC,OP AMP
U250	5171121L01	CUSTOM LOW VOLTAGE VCO BUFFER IC
U401	5185963A85	IC-ABACUS III-LP
U500	5188493T01	IC,VREG/SWG,LP2989, SM,IC MINI SO-8 HI PRCN REG 5V
U501	5185941F35	IC, VREG, NOPB
U502	5185941F35	IC, VREG, NOPB
U601	5185941F22	IC,OPAMP,SGL,OPA237, SOT23,NOPB
U602	5185941F22	IC,OPAMP,SGL,OPA237, SOT23,NOPB
U701	5185143E77	IC, MAKO ASIC, CMOS PWR MGMT
U702	5185941F22	IC,OPAMP,SGL,OPA237, SOT23,NOPB

ITEM	MOTOROLA PART NUMBER	DESCRIPTION
U705	5114000B39	IC,BFR,1PER PKG,SM, SOT-353,PB-FREE
U712	5188691V01	IC,MUX/DEMUX, NC7SB3157P6X,SM, SC70-6,1PER PKG, BUS, PB FREE
U713	5115453H01	RAIL TO RAIL OUTPUT, 8 PIN BGA
U714	5115453H01	RAIL TO RAIL OUTPUT, 8 PIN BGA
U800	5185941F04	IC, PATRIOT BRAVO, 1.2.2,256BGA, PB-FREE
U801	5114000B39	IC,BFR,1PER PKG,SM, SOT-353,PB-FREE
U802	5114000B39	IC,BFR,1PER PKG,SM, SOT-353,PB-FREE
U803	5185956E69	IC,DRAM,64MB,60NS,IC 1.8V 64
U804	5185941F03	IC,SRAM,8M,512KX16, 70NS,SM,FBGA48,1.95V
U807	5185941F45	ATTEN,VAR,14.4DBMIN, 15.6DBMAX,0-2000 MHZ FREQ,50OHM,PCMT
U809	5116349H01	DUAL INVERTER IC
VR500	4802245J51	ZENER DIODE; BZX284-C6V8
VR501	4813977M19	DIODE,ZEN,MBZ5240,SM, SOT-23,10V,10MA, .225W,ZEN,PB-FREE
VR502	4809788E21	DIODE, ZENER, SOD-323, SMD, W18 COMPLIANT
VR503	4809788E21	DIODE, ZENER, SOD-323, SMD, W18 COMPLIANT
VR504	4809788E21	DIODE, ZENER, SOD-323, SMD, W18 COMPLIANT

ITEM	MOTOROLA PART NUMBER	DESCRIPTION
VR505	4809788E21	DIODE, ZENER, SOD-323, SMD, W18 COMPLIANT
VR506	4809788E21	DIODE, ZENER, SOD-323, SMD, W18 COMPLIANT
VR507	4809788E21	DIODE, ZENER, SOD-323, SMD, W18 COMPLIANT
VR591	4813977A43	PB-FREE, ZENER, SM, DUAL 5.6V COM ANODE, SOT23 T&R
VR592	4813977A43	PB-FREE, ZENER, SM, DUAL 5.6V COM ANODE, SOT23 T&R
VR593	4813977A43	PB-FREE, ZENER, SM, DUAL 5.6V COM ANODE, SOT23 T&R
VR594	4813977A43	PB-FREE, ZENER, SM, DUAL 5.6V COM ANODE, SOT23 T&R
VR595	4813977A43	PB-FREE, ZENER, SM, DUAL 5.6V COM ANODE, SOT23 T&R
VR596	4813977A43	PB-FREE, ZENER, SM, DUAL 5.6V COM ANODE, SOT23 T&R
VR650	4813979P12	DIODE ARRAY,TRANSIENT PROTECTION,SM, SOT-457,12V,.225W, ZEN, 4,PB
VR651	4813977A43	PB-FREE, ZENER, SM, DUAL 5.6V COM ANODE, SOT23 T&R
VR652	4813977A43	PB-FREE, ZENER, SM, DUAL 5.6V COM ANODE, SOT23 T&R
VR657	4809788E21	DIODE, ZENER, SOD-323, SMD, W18 COMPLIANT

ITEM	MOTOROLA PART NUMBER	DESCRIPTION
VR658	4813977C23	DIODE,ZEN,MMSZ5243,SM,SOD-123,13V,10MA,.5W,ZEN,PB-FREE
VR659	4813979P10	DIODE ARRAY,TRANSIENT PROTECTION,SM,SOT-457,5.6V,.225W,ZEN,4,P
VR662	4813979P10	DIODE ARRAY,TRANSIENT PROTECTION,SM,SOT-457,5.6V,.225W,ZEN,4,P
VR663	4813977M18	DIODE,ZEN,MBZ5239,SM,SOT-23,9.1V,10MA,.225W,ZEN,PB-FREE
VR678	4866544A01	DIODE ARRAY,ZEN,SR05.TCT,SM,5V,5,LOW CAPACITANCE TVS DIO
VR701	4813977M11	DIODE,ZEN,MBZ5232,SM,SOT-23,5.6V,10MA,.225W,ZEN,PB-FREE
Y200	4802245J68	OSC, REF 16.8 MHZ 1.5 PPM
Y202	4805911Z02	RESONATOR CERAMIC
Y203	4885426C16	CER RESONATOR 1025 MHZ
Y701	4809995L05	XTAL QUARTZ 32.768KHZ CC4V-T1
Y702	4864005H01	RESONATOR, CRYSTAL 24.576 MHZ

Notes:

- For optimum performance, order replacement diodes, transistors, and circuit modules by Motorola part number only.
- When ordering crystals, specify carrier frequency, crystal frequency, crystal type number, and Motorola part number.
- Part value notations:
 $p=10^{-12}$
 $n=10^{-9}$
 $\mu=10^{-6}$
 $m=10^{-3}$
 $k=10^3$
 $M=10^6$
- ITEM refers to the component reference designator. SIDE refers to the location of the component on the board; S1=Side 1, S2=Side 2.
- The PMLD4303A RF Board uses a 6-layer printed circuit board.

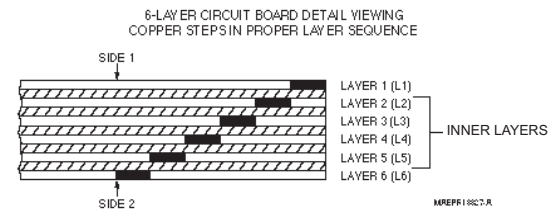

Notes

Appendix A Replacement Parts Ordering

A.1 Basic Ordering Information

When ordering replacement parts or equipment information, the complete identification number should be included. This applies to all components, kits, and chassis. If the component part number is not known, the order should include the number of the chassis or kit of which it is a part, and sufficient description of the desired component to identify it.

Crystal orders should specify the crystal type number, crystal and carrier frequency, and the model number in which the part is used.

A.2 Radio Board Ordering Information

When ordering a replacement Radio Board, refer to the applicable Model Chart in the front of this manual, read the note at the bottom of the Model Chart, and include the proper information with your order.

A.3 Motorola Online

Motorola Online users can access our online catalog at

<https://www.motorola.com/businessonline>

To register for online access:

- Domestic customers: please call 800-814-0601 (U.S. and Canada).
- International customers: please go to <https://www.motorola.com/businessonline> and click on "Sign Up Now."

A.4 Mail Orders

Send written orders to the following addresses:

**United States and Canada Orders
(except for U.S. Federal
Government orders):**

Motorola Inc.
Radio Products and
Services Division*
Attention: Order Processing
2200 Galvin Drive
Elgin, IL 60123
U.S.A.

U.S. Federal Government Orders:

Motorola Inc.
U.S. Federal Government
Markets Division
Attention: Order Processing
7230 Parkway Drive
Landover, MD 21076
U.S.A.

International Orders:

Motorola Inc.
Radio Products and
Services Division*
Attention: International
Order Processing
2200 Galvin Drive
Elgin, IL 60123
U.S.A.

A.5 Telephone Orders

Radio Products and Services Division*
(United States and Canada)
7:00 AM to 7:00 PM (Central Standard Time)
Monday through Friday (Chicago, U.S.A.)
1-800-422-4210
1-847-538-8023 (International Orders)

U.S. Federal Government Markets Division (USFGMD)
1-800-826-1913 Federal Government Parts - Credit Cards Only
8:30 AM to 5:00 PM (Eastern Standard Time)

A.6 Fax Orders

Radio Products and Services Division*
(United States and Canada)
1-800-622-6210
1-847-576-3023 (International)

USFGMD
(Federal Government Orders)
1-800-526-8641 (For Parts and Equipment Purchase Orders)

A.7 Parts Identification

Radio Products and Services Division*
(United States and Canada)
1-800-422-4210, menu 3

A.8 Product Customer Service

Customer Response Center
(Non-technical Issues)
1-800-247-2346
FAX:1-800-247-2347

*The Radio Products and Services Division (RPSD) was formerly known as the Customer Care and Services Division (CCSD) and/or the Accessories and Aftermarket Division (AAD).

Glossary

Term	Definition
A/D	Analog-to-Digital converter; converts an instantaneous dc voltage level to a corresponding digital value.
ABACUS IC	Custom integrated circuit providing a digital receiver intermediate frequency (IF) backend.
ALC	Automatic Level Control ; a circuit in the transmit RF path that controls RF power amplifier output, provides leveling over frequency and voltage, and protects against high VSWR.
CODEC	COder/DECoder.
D/A	Digital-to-Analog converter; converts a digital value to a corresponding dc voltage value.
DSP	Digital Signal Processor. A microcontroller specifically tailored for signal processing computations.
DSP Code	Digital Signal Processor Code ; object code executed by the Digital Signal Processor in an ASTRO XTS 2500/XTS 2500I subscriber radio. The DSP is responsible for computation-intensive tasks, such as decoding ASTRO signaling.
Firmware	Code executed by an embedded processor such as the Host or DSP in a subscriber radio. This type of code is typically resident in non-volatile memory and as such is more difficult to change than code executed from RAM.
FGU	Frequency Generation Unit. This unit generates ultra-stable, low-phase noise master clock and other derived synchronization clocks that are distributed throughout the communication network.
FLASHcode	A 13-digit code which uniquely identifies the System Software Package and Software Revenue Options that are enabled in a particular subscriber radio. FLASHcodes are only applicable for radios which are upgradeable through the FLASHport process.
FLASHport™	A Motorola term that describes the ability of a radio to change memory. Every FLASHport radio contains a FLASHport EEPROM memory chip that can be software written and rewritten to, again and again.
FracN	A Motorola-proprietary, CMOS fractional-N frequency synthesizer with built-in dual-port modulation.
Host	The Motorola microcontroller unit.

Term	Definition
Host Code	Object code executed by the Host Processor in an ASTRO subscriber radio. The Host is responsible for control-oriented tasks such as decoding and responding to user inputs.
Host Port	Parallel memory mapped interface consisting of eight registers in the DSP.
IC	Integrated C ircuit. An assembly of interconnected components on a small semiconductor chip, usually made of silicon. One chip can contain millions of microscopic components and perform many functions.
IMBE	A sub-band, voice encoding algorithm used in ASTRO digital voice.
ISW	Inbound S ignaling W ord; data transmitted on the control channel from a subscriber unit to the central control unit.
KRSIC	Digital Signal Processor S upport I C; custom integrated circuit providing peripheral functions for the DSP.
LSH	Low S peed H andshake; 150 baud digital data sent to the radio during trunked operation while receiving audio.
MAKO	Power Management Integrated Circuit.
MCU	M icro C ontroller U nit. Also written as μC . A microprocessor that contains RAM and ROM components, as well as communications and programming peripherals.
Open Architecture	A controller configuration that utilizes a microprocessor with extended ROM, RAM, and EEPROM.
OSW	Outbound S ignaling W ord; data transmitted on the control channel from the central controller to the subscriber unit.
PC Board	P rinted C ircuit board.
PCIC	P ower C ontrol Integrated C ircuit. The power control IC is intended for closed-loop bias control of power amplifiers. The device facilitates accurate control of the current delivered to the power amplifier (PA) via a control voltage.
PL	Private-Line [®] tone squelch; a continuous sub-audible tone that is transmitted along with the carrier.
PLL	P hase- L ocked L oop; a circuit in which an oscillator is kept in phase with a reference, usually after passing through a frequency divider.
PTT	P ush- T o- T alk; the switch located on the left side of the radio which, when pressed, causes the radio to transmit.
Registers	Short-term data-storage circuits within the microcontroller unit or programmable logic IC.

Term	Definition
Repeater	Remote transmit/receive facility that re-transmits received signals in order to improve communications coverage.
RESET	Reset line; an input to the microcontroller that restarts execution.
RF PA	Radio Frequency Power Amplifier . Amplifier having one or more active devices to amplify radio signals.
RSS	Radio Service Software .
RPT/TA	RePeaTer/Talk-Around .
RX DATA	Recovered digital data line.
Serial Communication Interface Input Line (SCI IN)	A full-duplex (receiver/transmitter) asynchronous serial interface.
Signal Qualifier Mode	An operating mode in which the radio is muted, but still continues to analyze receive data to determine RX signal type.
SCI IN	Serial Communication Interface IN put line.
Smart RIB	Smart Radio Interface Box ; a service aid that enables communications between the radio and the computer's serial communications adapter. Used in conjunction with the RSS to read the DSP Code, FLASHcode, Host Code, and model number.
Softpot	Software potentiometer; a computer-adjustable electronic attenuator.
Software	Computer programs, procedures, rules, documentation, and data pertaining to the operation of a system.
SPI	Serial Peripheral Interface ; how the microcontroller communicates to modules and ICs through the CLOCK and DATA lines.
Squelch	Muting of audio circuits when received signal levels fall below a pre-determined value.
SRAM	Static-RAM chip used for volatile, program/data memory.
SSI	Synchronous Serial Interface on the DSP, consisting of six signals and used for an RX and TX modulated data interface to the KRSIC.
Standby Mode	An operating mode whereby the radio is muted but still continues to monitor data.
System Central Controllers	Main control unit of the trunked dispatch system; handles ISW and OSW messages to and from subscriber units (see ISW and OSW).
System Select	The act of selecting the desired operating system with the system-select switch (also, the name given to this switch).

Term	Definition
TSOP	Thin Small-Outline Package. A type of dynamic random-access memory (DRAM) package that is commonly used in memory applications.
UART	Universal Asynchronous Receiver Transmitter. A microchip with programming that controls a computer's interface to its attached serial devices.
VCO	Voltage-Controlled Oscillator; an oscillator in which the frequency of oscillation can be varied by changing a control voltage.
VCOB IC	Voltage-Controlled Oscillator Buffer IC.
Vocoder	VO ice en CODER ; the DSP-based system for digitally processing the analog signals, includes the capabilities of performing voice compression algorithms or voice encoding.
VSELP	Vector Sum Excited Linear Predictive coding; a voice encoding technique used in ASTRO digital voice.
VSWR	Voltage Standing Wave Ratio. The ratio of the maximum voltage to the minimum voltage on a transmission line. An indicator of how well an RF device's input or output impedance matches the nominal impedance of the system.

Index

Numerics

5V routing, VOCON . . . 3.1-3, 3.2-3, 3.3-3, 3.4-3, 3.5-3

A

Abacus IC U401 4.1-3, 4.2-4, 4.3-4
 algorithms, encryption module . . 4.1-16, 4.2-16, 4.3-16,
 4.4-16, 4.5-16
 analog mode
 receiving 2.1-1, 2.2-1, 2.3-1, 2.4-1, 2.5-1
 transmitting 2.1-2, 2.2-2, 2.3-2, 2.4-2, 2.5-2
 antenna switch
 receive mode 4.1-2, 4.2-2, 4.3-2
 transmit mode 4.1-2, 4.2-2, 4.3-2, 4.4-2, 4.5-2
 ASTRO (digital) mode . . 2.1-2, 2.2-2, 2.3-2, 2.4-2, 2.5-2

B

B+ routing
 main board 3.1-2, 3.3-2, 3.4-2, 3.5-2
 VOCON 3.1-3, 3.2-3, 3.3-3, 3.4-3, 3.5-3
 basic ordering information A-1
 batteries, acceptable . . . 3.1-1, 3.2-1, 3.3-1, 3.4-1, 3.5-1
 block diagram, radio interconnect 9.1-2, 9.2-2
 board layouts 9.1-1, 9.2-1, 9.3-1, 9.4-1, 9.5-1

C

caution symbol 1-1
 characteristics, radio . . . 2.1-1, 2.2-1, 2.3-1, 2.4-1, 2.5-1
 codes, power-up self-check error 5-3

D

danger symbol 1-2
 DC routing
 main board B+ 3.1-2, 3.3-2, 3.4-2, 3.5-2
 supply voltages 3.1-4, 3.2-4, 3.3-4, 3.4-4, 3.5-4
 VOCON 5V 3.1-3, 3.2-3, 3.3-3, 3.4-3, 3.5-3
 VOCON B+ 3.1-3, 3.2-3, 3.3-3, 3.4-3, 3.5-3
 diagnostics, power-up and self-check 5-4
 digital (ASTRO) mode . . 2.1-2, 2.2-2, 2.3-2, 2.4-2, 2.5-2

E

encryption
 module algorithms 4.1-16, 4.2-16, 4.3-16, 4.4-16,
 4.5-16

F

FLASH U402 pinout 8.2-3, 8.3-3, 8.4-3, 8.5-3
 FLASH U803 pinout 8.1-3
 frequency synthesis . . . 4.1-1, 4.2-1, 4.3-1, 4.4-1, 4.5-1

G

glossary Glossary-1

H

handling precautions, CMOS devices 5-1

I

IC
 Abacus U401 4.1-3, 4.2-4, 4.3-4
 CMOS handling precautions 5-1

K

key variable loader (KVL) 4.1-16, 4.2-16, 4.3-16, 4.4-16,
 4.5-16
 KVL (key variable loader) 4.1-16, 4.2-16, 4.3-16, 4.4-16,
 4.5-16

M

main board overview . . . 2.1-2, 2.2-2, 2.3-2, 2.4-2, 2.5-2
 main board to key flex assembly J601 pinout . . . 8.1-1,
 8.2-1, 8.3-1, 8.4-1, 8.5-1
 main board to universal (side) connector flex assembly
 J601 pinout . . . 8.1-3, 8.2-3, 8.3-3, 8.4-3, 8.5-3
 manual
 contents overview 1-1
 introduction 1-1
 notations 1-1
 mode
 analog receiving 2.1-1, 2.2-1, 2.3-1, 2.4-1, 2.5-1
 analog transmitting . . . 2.1-2, 2.2-2, 2.3-2, 2.4-2, 2.5-2
 ASTRO (digital) 2.1-2, 2.2-2, 2.3-2, 2.4-2, 2.5-2

N

notations, manual 1-1

O

overview
 main board 2.1-2, 2.2-2, 2.3-2, 2.4-2, 2.5-2
 service manual 1-1
 vocoder 2.1-3, 2.2-3, 2.3-3, 2.4-3, 2.5-3

P

parts list 9.1-29 to 9.1-36, 9.2-30 to 9.2-39,
 9.3-28 to 9.3-36, 9.4-20 to 9.4-28,
 9.5-19 to 9.5-31
 Patriot MCU/DSP U401 pinout 8.2-7, 8.3-7, 8.4-7, 8.5-7
 Patriot MCU/DSP U800 pinout 8.1-7
 power down sequence . . 3.1-1, 3.2-1, 3.3-1, 3.4-1, 3.5-1
 power up sequence . . . 3.1-1, 3.2-1, 3.3-1, 3.4-1, 3.5-1
 power-up self-check error codes 5-3
 power-up, self-check diagnostics and repair 5-4
 procedures, troubleshooting 5-1

R

radio

- board layouts 9.1-1, 9.2-1, 9.3-1, 9.4-1, 9.5-1
- interconnect block diagram 9.1-2, 9.2-2
- overall characteristics 2.1-1, 2.2-1, 2.3-1, 2.4-1, 2.5-1
- parts list 9.1-29 to 9.1-36, 9.2-30 to 9.2-39,
. 9.3-28 to 9.3-36, 9.4-20 to 9.4-28,
. 9.5-19 to 9.5-31
- power down 3.1-1, 3.2-1, 3.3-1, 3.4-1, 3.5-1
- power up 3.1-1, 3.2-1, 3.3-1, 3.4-1, 3.5-1
- schematics 9.1-1, 9.2-1, 9.3-1, 9.4-1, 9.5-1
- radio board ordering information A-1
- receiver
 - front end theory 4.1-3, 4.2-3, 4.3-3, 4.4-3, 4.5-3
- replacement parts ordering
 - mail orders A-1

S

- schematics 9.1-1, 9.2-1, 9.3-1, 9.4-1, 9.5-1
- signal tracing procedures 5-1
- SRAM U403 pinout 8.2-6, 8.3-6, 8.4-6, 8.5-6
- SRAM U804 pinout 8.1-6
- standard bias table 5-2
- supply voltages, standard 5-2
- symbol
 - caution 1-1
 - danger 1-2
 - warning 1-1
- system clocks 5-2

T

theory of operation

- Abacus IC U401 4.1-3, 4.2-4, 4.3-4
- antenna switch
 - receive mode 4.1-2, 4.2-2, 4.3-2
 - transmit mode 4.1-2, 4.2-2, 4.3-2, 4.4-2, 4.5-2
- frequency synthesis 4.1-1, 4.2-1, 4.3-1, 4.4-1, 4.5-1
- receiver
 - front end 4.1-3, 4.2-3, 4.3-3, 4.4-3, 4.5-3

troubleshooting charts

- button test 6.1-9, 6.2-9, 6.3-9, 6.4-9, 6.5-9
- DC supply fail 6.1-6, 6.2-6, 6.3-6, 6.4-6, 6.5-6
- listing 6.1-1, 6.2-1, 6.3-1, 6.4-1, 6.5-1
- no display 6.1-13, 6.2-13, 6.3-13, 6.4-13, 6.5-13
- no transmit deviation 6.1-21, 6.2-21, 6.3-21, 6.4-21,
. 6.5-21
- radio power-up fail 6.1-3, 6.2-3, 6.3-3, 6.4-3, 6.5-3
- top/side button error 6.1-12, 6.2-12, 6.3-12, 6.4-12,
. 6.5-12
- volume set error 6.1-10, 6.2-10, 6.3-10, 6.4-10, 6.5-10

troubleshooting procedures

- handling precautions 5-1
- power-up self-check error codes 5-3
- power-up, self-check diagnostics and repair 5-4
- radio 5-1
- signal tracing 5-1
- standard bias table 5-2
- system clocks 5-2
- voltage measurements 5-1

troubleshooting tables

- FLASH U402 pinout 8.2-3, 8.3-3, 8.4-3, 8.5-3
- FLASH U803 pinout 8.1-3
- main board to key flex assembly J601 8.1-1, 8.2-1,
. 8.3-1, 8.4-1, 8.5-1
- main board to universal (side) connector flex assembly
J601 8.1-3, 8.2-3, 8.3-3, 8.4-3, 8.5-3
- Patriot MCU/DSP U401 pinout 8.2-7, 8.3-7, 8.4-7,
. 8.5-7
- Patriot MCU/DSP U800 pinout 8.1-7
- SRAM U403 pinout 8.2-6, 8.3-6, 8.4-6, 8.5-6
- SRAM U804 pinout 8.1-6
- troubleshooting waveforms
 - 16.8 MHz buffer input and output 7.1-36, 7.2-37,
7.3-36, 7.4-39, 7.5-39
 - 1st LO control voltage 7.1-18, 7.2-18, 7.3-18, 7.4-19,
. 7.5-19
 - 2nd LO control voltage 7.1-31, 7.2-32, 7.3-31, 7.4-34,
. 7.5-34
 - 2nd LO VCO buffer output 7.1-32, 7.2-33, 7.3-32,
. 7.4-35, 7.5-35
 - 32.768 kHz clock outputs 7.1-37, 7.2-38, 7.3-37,
. 7.4-40, 7.5-40
- abacus analog 3V 7.1-30, 7.2-31, 7.3-30, 7.4-33,
. 7.5-33
- abacus digital 3V 7.1-34, 7.2-35, 7.3-34, 7.4-37,
. 7.5-37
- analog 5V 7.1-24, 7.1-33, 7.2-25, 7.2-34, 7.3-24,
7.3-33, 7.4-27, 7.4-36, 7.5-27, 7.5-36
- antenna input 7.1-6, 7.2-6, 7.3-6, 7.4-6, 7.5-6
- antenna switch bias 7.1-22, 7.2-23, 7.3-22, 7.4-24,
. 7.5-24
- coupler RF feedback to PCIC 7.1-10, 7.2-10, 7.3-10,
. 7.4-10, 7.5-10
- coupler RF out 7.1-8, 7.2-8, 7.3-8, 7.4-8, 7.5-8
- crystal filter out 7.1-29, 7.2-30, 7.3-29, 7.4-32, 7.5-32
- frequency out (16.8 MHz) 7.1-20, 7.2-21, 7.3-20,
. 7.4-22, 7.5-22
- higher level voltage multiplier 7.1-13, 7.2-13, 7.3-13,
. 7.4-13, 7.5-13
- list 7.1-1, 7.2-1, 7.3-1, 7.4-1, 7.5-1
- low-noise amplifier output 7.1-26, 7.2-27, 7.3-26,
7.4-29, 7.5-29
- mixer out (IF) 7.1-28, 7.2-29, 7.3-28, 7.4-31, 7.5-31
- mod in 7.1-17, 7.2-17, 7.3-17, 7.4-18, 7.5-18
- PA control voltage 7.1-11, 7.2-11, 7.3-11, 7.4-11,
. 7.5-11
- prescaler input to FracN synthesizer 7.1-15, 7.2-15,
7.3-15, 7.4-16, 7.5-16
- preselector 1 output 7.1-25, 7.2-26, 7.3-25, 7.4-28,
. 7.5-28
- preselector 2 output 7.1-27, 7.2-28, 7.3-27, 7.4-30,
. 7.5-30
- preselector tuning voltage 7.1-23, 7.2-24, 7.3-23,
. 7.4-25, 7.5-25
- reference crystal output 7.1-16, 7.2-16, 7.3-16,
. 7.4-17, 7.5-17
- RX RF input after antenna switch 7.4-26, 7.5-26
- RX RF input at antenna switch 7.1-21, 7.2-22, 7.3-21,
. 7.4-23, 7.5-23
- RX serial audio port (SAP) 7.1-39, 7.2-40, 7.3-39,
. 7.4-42, 7.5-42
- SPI B data 7.1-38, 7.2-39, 7.3-38, 7.4-41, 7.5-41
- superfilter output 7.1-14, 7.2-14, 7.3-14, 7.4-14,
. 7.5-14
- TRB 7.4-15, 7.5-15

-
- TX audio 1 kHz tone . . . 7.1-35, 7.2-36, 7.3-35, 7.4-38,
 7.5-38
- TX LO 7.1-12, 7.2-12, 7.3-12, 7.4-12, 7.5-12
- TX signal at harmonic filter input . . . 7.1-7, 7.2-7, 7.3-7,
 7.4-7, 7.5-7
- TX signal at PA 7.1-9, 7.2-9, 7.3-9, 7.4-9, 7.5-9
- VCO output 7.1-19, 7.2-19, 7.3-19, 7.4-20, 7.5-20
- VCO RX LO 7.4-21, 7.5-21
- V**
- vocoder overview 2.1-3, 2.2-3, 2.3-3, 2.4-3, 2.5-3
- voltage measurement procedures 5-1
- W**
- warning symbol 1-1
- waveforms, troubleshooting
- 16.8 MHz buffer input and output 7.1-36, 7.2-37,
 7.3-36, 7.4-39, 7.5-39
- 1st LO control voltage . 7.1-18, 7.2-18, 7.3-18, 7.4-19,
 7.5-19
- 2nd LO control voltage . 7.1-31, 7.2-32, 7.3-31, 7.4-34,
 7.5-34
- 2nd LO VCO buffer output 7.1-32, 7.2-33, 7.3-32,
 7.4-35, 7.5-35
- 32.768 kHz clock outputs 7.1-37, 7.2-38, 7.3-37,
 7.4-40, 7.5-40
- abacus analog 3V 7.1-30, 7.2-31, 7.3-30, 7.4-33,
 7.5-33
- abacus digital 3V 7.1-34, 7.2-35, 7.3-34, 7.4-37,
 7.5-37
- analog 5V 7.1-24, 7.1-33, 7.2-25, 7.2-34, 7.3-24,
 7.3-33, 7.4-27, 7.4-36, 7.5-27, 7.5-36
- antenna input 7.1-6, 7.2-6, 7.3-6, 7.4-6, 7.5-6
- antenna switch bias . . . 7.1-22, 7.2-23, 7.3-22, 7.4-24,
 7.5-24
- coupler RF feedback at PCIC . 7.1-10, 7.2-10, 7.3-10,
 7.4-10, 7.5-10
- coupler RF out 7.1-8, 7.2-8, 7.3-8, 7.4-8, 7.5-8
- crystal filter out 7.1-29, 7.2-30, 7.3-29, 7.4-32, 7.5-32
- frequency out (16.8 MHz) 7.1-20, 7.2-21, 7.3-20,
 7.4-22, 7.5-22
- higher level voltage multiplier . 7.1-13, 7.2-13, 7.3-13,
 7.4-13, 7.5-13
- list 7.1-1, 7.2-1, 7.3-1, 7.4-1, 7.5-1
- low-noise amplifier output 7.1-26, 7.2-27, 7.3-26,
 7.4-29, 7.5-29
- mixer out (IF) 7.1-28, 7.2-29, 7.3-28, 7.4-31, 7.5-31
- mod in 7.1-17, 7.2-17, 7.3-17, 7.4-18, 7.5-18
- PA control voltage 7.1-11, 7.2-11, 7.3-11, 7.4-11,
 7.5-11
- prescaler input to FracN synthesizer . 7.1-15, 7.2-15,
 7.3-15, 7.4-16, 7.5-16
- preselector 1 output . . . 7.1-25, 7.2-26, 7.3-25, 7.4-28,
 7.5-28
- preselector 2 output . . . 7.1-27, 7.2-28, 7.3-27, 7.4-30,
 7.5-30
- preselector tuning voltage 7.1-23, 7.2-24, 7.3-23,
 7.4-25, 7.5-25
- reference crystal output 7.1-16, 7.2-16, 7.3-16,
 7.4-17, 7.5-17
- RX RF input after antenna switch 7.4-26, 7.5-26
- RX RF input at antenna switch . 7.1-21, 7.2-22, 7.3-21,
 7.4-23, 7.5-23
- RX serial audio port (SAP) 7.1-39, 7.2-40, 7.3-39,
 7.4-42, 7.5-42
- SPI B data 7.1-38, 7.2-39, 7.3-38, 7.4-41, 7.5-41
- superfilter output 7.1-14, 7.2-14, 7.3-14, 7.4-14,
 7.5-14
- TRB 7.4-15, 7.5-15
- TX audio 1 kHz tone . . . 7.1-35, 7.2-36, 7.3-35, 7.4-38,
 7.5-38
- TX LO 7.1-12, 7.2-12, 7.3-12, 7.4-12, 7.5-12
- TX signal at harmonic filter input . 7.1-7, 7.2-7, 7.3-7,
 7.4-7, 7.5-7
- TX signal at PA 7.1-9, 7.2-9, 7.3-9, 7.4-9, 7.5-9
- VCO output 7.1-19, 7.2-19, 7.3-19, 7.4-20, 7.5-20
- VCO RX LO 7.4-21, 7.5-21
-

Notes



MOTOROLA

Motorola, Inc.
8000 West Sunrise Boulevard
Ft. Lauderdale, FL 33322

MOTOROLA, the Stylized M Logo, ASTRO,
and SmartZone are registered in the U.S.
Patent & Trademark Office.
All other product or service names are the
property of their respective owners.
© Motorola, Inc. 2007.
All rights reserved. Printed in U.S.A.



6816985H01-B