

Kwick-Eject™ Automatic AC Cord Disconnect

Kwick-Eject™ Automatic AC Cord Disconnect

Newmar battery chargers are now available with a vehicle mount AC power cord eject device made by industry leader Havis-Shields. This system provides all the features you require in a power line disconnect and charging system, all available from Newmar as a convenient single source.

- **Heavy duty** trigger springs and a large diameter eject ram ensure quick release and 'throw' of plug and cord clear of the vehicle when engine is started.
- **No plug arc on disconnect:** On board AC Load (battery charger) is disconnected prior to eject, prevents plug blade arcing and burn-up caused by live load disconnect. No more replacing charred plugs.
- **Corrosion protection:** All parts are Sealed in a protective molded housing to prevent dirt and road salt from damaging the springs and solenoid switches.
- **Secure** retracting cover plate with weatherproof seal closes over socket aperture protecting it from the elements, road salt and dirt. Stainless steel torsion springs and roller provide years of trouble free service in the hostile emergency vehicle applications.
- **Extensive testing** assures long service. The device has been accelerated life tested over 10,000 cycles to ensure faultless service emergency vehicle applications.
- **Easy to install or retrofit:** The Kwick-Eject has the identical mounting hole pattern as other Emergency Vehicle inlets so it can be added to new trucks easily and can also be installed on existing fleet as a replacement.
- **Professional appearance retrofit:** cover plate assembly has easy to read label which listing the incoming voltage, cycles, and Amperage rating. Safety Yellow cover standard - Red or White optional.
- **Two year Warranty** begins at in-service date of vehicle.

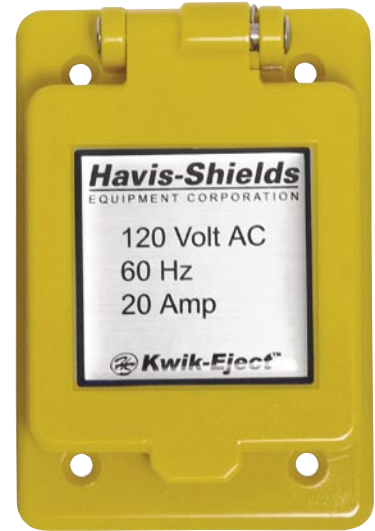

Models: (specify cover color - red, white or yellow)

Kwick-Eject™ - 15 amp - 120 Volts (NEMA 5-15)

Kwick-Eject™ - 20 amp - 120 Volts (NEMA 5-20)

Kwick-Eject™ - 15 amp - 220 Volts (NEMA 6-15)

Your Choice of Colors



Mounting Template:

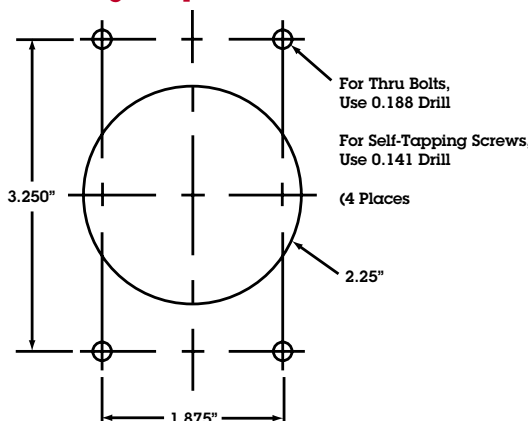

Plug Configurations

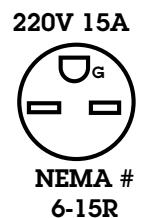

DC Power Onboard - Emergency & Specialty Vehicles